



Cat[®] 308E2 CR VAB

MINI HYDRAULIC EXCAVATOR WITH VARIABLE ANGLE BOOM

FEATURES:

The Cat[®] 308E2 CR VAB Mini Hydraulic Excavator delivers high performance, durability and versatility in a compact design to help you work in a variety of applications. The 308E2 CR VAB features the following:

QUALITY

- The durable hoods and frame and the compact radius design of the 308E2 CR VAB let you work comfortably and confidently in confined areas.
- The operator environment includes a high quality suspension seat, easy to adjust armrests and 100% pilot controls which offer consistent and long-lasting controllability.

EFFICIENCY

- High Definition Hydraulic System provides a load sensing and flow sharing capability leading to operational precision, efficient performance and greater controllability.
- Power on Demand provides optimal efficiency and performance the moment you need it. This automatic system ensures fuel efficiency through appropriate engine rating to meet all operational needs as required.

DURABLE FRONT LINKAGE

- Uptime and service intervals are increased with durable and reliable booms, sticks, and linkage pins. Each boom and stick is built to provide superior strength to withstand any tough application.
- Variable angle boom option offers flexibility and versatility in the working envelope. With full extension, the working range gives maximum dig depth, reach and working height. When retracted, it can work closer to the blade and tracks, provide increased lifting capacity and work productively in confined areas.

PERFORMANCE

- Front shovel bucket orientation provides the operator with more ways to get the job done faster.
- COMPASS Control Panel is a standard feature that allows the operator to easily adjust auxiliary flows to achieve the optimal work tool performance, activate auto idle for improved fuel efficiency and utilize the security system to ensure protection of valuable assets with the simple touch of a button.
- The Site Reference System included in the COMPASS monitor provides output from pitch and roll sensors to aid in grading and level trenching. This impacts accuracy and productivity for job site finishing.
- Rearview camera improves operator productivity and efficiency through increased visibility, making work easier to complete.

SERVICEABILITY

- Convenient service and maintenance requirements include ease of access to daily check points, 500 hour engine oil and filter change period, 500 hour grease interval on front implement, S-O-SSM oil sampling valve and overall long term durability.

SAFETY

- All Cat Mini Excavators from 3.5 metric tons to 8 metric tons are ROPS, TOPS and Top Guard Level II certified and include the Cat Interlock (hydraulic lockout) System, a certified accumulator which allows for auxiliary pressure to be released, making connecting and disconnecting work tools safer and easier, and a travel alarm. All of these safety features are standard on the E2 model lineup (travel alarm optional in Europe).

Specifications

Engine

Engine Model*	Cat C3.3B	
Rated Net Power @ 2,000 rpm ISO 9249/EEC 80/1269	48.5 kW	65.0 hp
Gross Power ISO 14396	49.7 kW	66.6 hp
Bore	94 mm	3.7 in
Stroke	120.0 mm	4.7 in
Displacement	3.3 L	201 in ³

*Meets U.S. EPA Tier 4 Final/EU Stage IIIB emission standards.

Weights*

Weight – Cab, Standard Stick	8700 kg	19,184 lb
------------------------------	---------	-----------

*Weight includes counterweight, rubber tracks, bucket, operator, full fuel and auxiliary lines.



308E2 CR VAB Mini Hydraulic Excavator with Variable Angle Boom

Swing System

Machine Swing Speed	11 rpm
Boom Swing – Left	60°
Boom Swing – Right	50°

Travel System

Travel Speed – High	5.3 km/h	3.3 mph
Travel Speed – Low	3.3 km/h	2.1 mph
Max Traction Force – High Speed	35.8 kN	8,048 lb
Max Traction Force – Low Speed	61.8 kN	13,893 lb
Ground Pressure – Cab	63.5 kPa	9.2 psi
Gradeability (continuous operation)	20°	
Gradeability (<10 minutes operation)	30°	

Service Refill Capacities

Cooling System	14.0 L	3.7 gal
Engine Oil	11.2 L	3.0 gal
Fuel Tank	125.0 L	33.0 gal
Hydraulic Tank	82.0 L	21.7 gal
Hydraulic System	94.0 L	24.8 gal

Hydraulic System

Load Sensing Hydraulics with Variable Displacement Piston Pump		
Pump Flow at 2,000 rpm	150 L/min	39.6 gal/min
Operating Pressure – Equipment	280 bar	4,060 psi
Operating Pressure – Travel	280 bar	4,060 psi
Operating Pressure – Swing	240 bar	3,480 psi
Auxiliary Circuit – Primary (280 bar/4,061 psi)	128 L/min	33.8 gal/min
Auxiliary Circuit – Secondary (280 bar/4,061 psi)	64 L/min	16.9 gal/min
Digging Force – Stick (standard)	33.4 kN	7,509 lb
Digging Force – Bucket	57.5 kN	12,927 lb

Blade

Width	2320 mm	91.3 in
Height	450 mm	17.7 in
Dig Depth	360 mm	14.2 in
Lift Height	380 mm	15.0 in

Cab

Dynamic Operator Sound Pressure Level (ISO 6396:2008)	70 dB(A)
Exterior Sound Power Level (ISO 6395:2008)*	99 dB(A)

*European Union Directive “2000/14/EC”

Air Conditioning System

The air conditioning system on this machine contains the fluorinated greenhouse gas refrigerant R134a (Global Warming Potential = 1430). The system contains 1.3 kg (2.9 lb) of refrigerant which has a CO₂ equivalent of 1.9 metric tonnes (4,189 lb).

Certification – Cab and Canopy

Roll Over Protective Structure (ROPS)	ISO 12117-2
Tip Over Protective Structure (TOPS)	ISO 12117
Top Guard	ISO 10262 (Level II)

Operating Specifications

Stick Length – Standard	1665 mm	66 in
Machine Overhang	290 mm	11 in
Machine Overhang with Extra Counterweight	405 mm	16 in

Undercarriage

Number of Carrier Rollers	1/side
Number of Track Rollers	5/side
Track Roller Type (Rubber Belt)	Center Flange

Lift Capacities at Ground Level – VAB Minimum*

Lift Point Radius		5000 mm (16'5")		5500 mm (18'1")	
		Front	Side	Front	Side
Blade Down	kg	2354	1070	902	902
	(lb)	(5,191)	(2,359)	(1,989)	(1,989)
Blade Up	kg	1294	1070	902	902
	(lb)	(2,853)	(2,359)	(1,989)	(1,989)

Lift Capacities at Ground Level – VAB Maximum*

Lift Point Radius		5000 mm (16'5")		6800 mm (22'4")	
		Front	Side	Front	Side
Blade Down	kg	2479	945	1451	575
	(lb)	(5,466)	(2,084)	(3,199)	(1,268)
Blade Up	kg	1164	945	714	575
	(lb)	(2,567)	(2,084)	(1,574)	(1,268)

*The above loads are in compliance with hydraulic excavator lift capacity rating standard ISO 10567:2007 and they do not exceed 87% of hydraulic lifting capacity or 75% of tipping capacity. The excavator bucket weight is not included on this chart. Lifting capacities are for standard stick.

308E2 CR VAB Mini Hydraulic Excavator with Variable Angle Boom

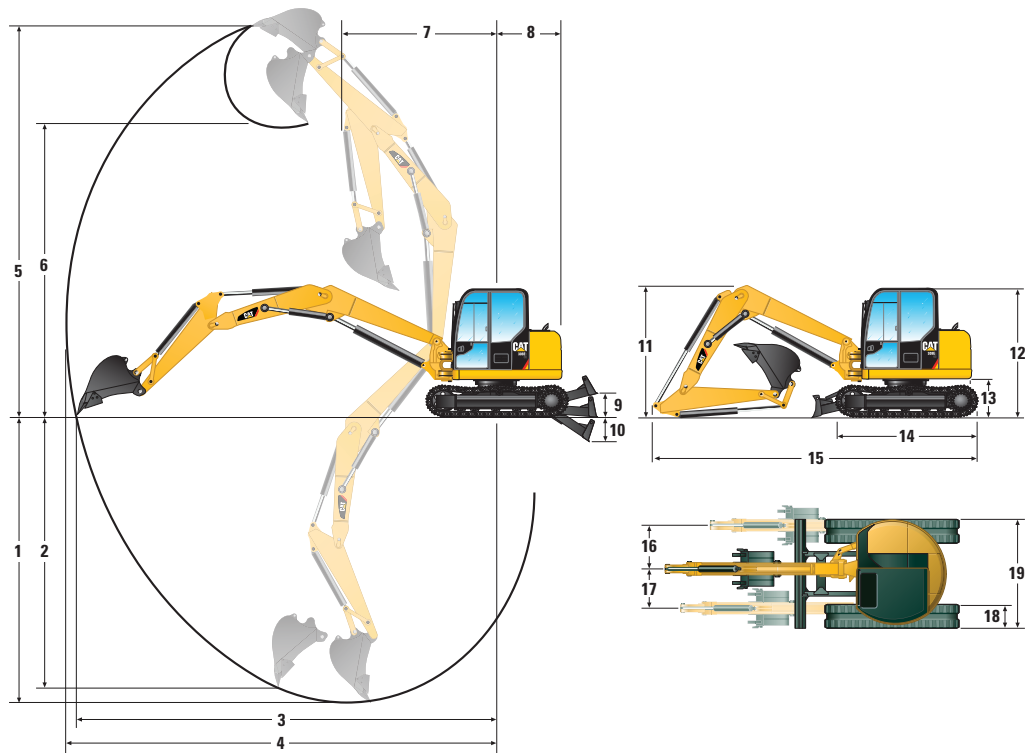

Dimensions

	Standard Stick with Angle Boom Extended		Standard Stick with Angle Boom Retracted	
	mm	in	mm	in
1 Dig Depth	3980	157	3710	146
2 Vertical Wall	3820	150	3600	142
3 Maximum Reach at Ground Level	7632	300	6365	251
4 Maximum Reach	7780	306	6550	258
5 Maximum Dig Height	8000	315	5200	205
6 Maximum Dump Clearance	6080	239	3360	132
7 Linkage In Minimum Radius	2925	115	3235	127
8 Tail Swing – Standard Counterweight	1450	57	1450	57
Tail Swing – with Extra Counterweight	1565	62	1565	62
9 Maximum Blade Height	420	17	420	17
10 Maximum Blade Depth	320	13	320	13
11 Boom Height in Shipping Position	2280	90	2200	87
12 O/A Shipping Height	2550	100	2550	100
13 Swing Bearing Height	735	29	735	29
14 O/A Undercarriage Length	2903	114	2903	114
15 O/A Shipping Length	7010	276	5795	228
16 Boom Swing Right	1010	40	1010	40
17 Boom Swing Left	635	25	635	25
18 Track Belt/Shoe Width	450	18	450	18
19 O/A Track Width	2320	91	2320	91

308E2 CR VAB Mini Hydraulic Excavator with Variable Angle Boom

STANDARD EQUIPMENT

ENGINE

- Cat C3.3B diesel engine (meets U.S. EPA Tier 4 Final/EU Stage IIIB emission standards)
- Automatic engine idle
- Automatic engine shut-off
- Automatic two speed travel
- Diesel Particulate Filter (North America only)
- Diesel Oxidation Catalyst (North America only)
- Fuel and water separator
- Power on demand

HYDRAULIC SYSTEM

- 1-way and 2-way (combined function)
- Accumulator
- Automatic swing parking brake
- Auxiliary hydraulic lines
- Adjustable auxiliary relief
- Auxiliary line quick disconnects
- Cat interlock system: hydraulic lockout
- Continuous auxiliary flow
- Ecology drain
- Hydraulic oil cooler
- High definition hydraulics
- Load sensing/flow sharing

OPERATOR ENVIRONMENT

- 100% pilot control ergonomic joysticks
- Adjustable armrests
- Air conditioning/heat

- COMPASS: complete, operation, maintenance, performance and security system
 - Multiple languages
- Cup holder
- High back suspension seat, heated
- Hydraulic neutral lockout bar
- Interior light
- Literature holder
- Pattern changer (optional in Europe)
- Radio (optional in Europe)
- Site reference system: leveling
- Tool storage area
- Travel control pedals with hand levers
- Washable floor mat
- Windshield wiper

UNDERCARRIAGE

- Dozer blade with float function
- Track, rubber belt, 450 mm (18 in) width
- Tie down eyes on track frame
- Towing eye on base frame

FRONT LINKAGE

- 180 degree bucket rotation
- Certified lifting eye on bucket linkage (optional in Europe)
- Front shovel capable
- Thumb ready stick

ELECTRICAL

- 12 volt electrical system
- 60 ampere alternator
- 650 CCA maintenance free battery
- Fuse box
- Ignition key start/stop switch
- Slow blow fuse
- Warning horn

LIGHTS AND MIRRORS

- Cab and boom light with time delay capability
- Mirror, rear view, cab left

SAFETY AND SECURITY

- Anti-theft system (COMPASS)
- Caterpillar Corporate "One Key" System
- Door locks
- Lockable fuel cap
- Rearview camera
- Retractable seat belt
- Roll Over Protective Structure (ROPS) (ISO 12117-2)
- Tip Over Protective Structure (TOPS) (ISO 12117)
- Top guard – ISO 10262 (Level II)
- Travel alarm (optional in Europe)

OPTIONAL EQUIPMENT

ENGINE

- Engine block heater

HYDRAULIC SYSTEM

- Quick coupler lines
- Boom lowering check valve*
- Stick lowering check valve*
- Secondary auxiliary hydraulic lines*

UNDERCARRIAGE

- Blade, weld on
- Track, triple grouser (steel), 450 mm (18 in)
- Track, triple grouser (steel) with rubber pad, 450 mm (18 in)
- Track, triple grouser (steel), 600 mm (24 in)

FRONT LINKAGE

- Quick coupler: manual or hydraulic
- Thumb
- Buckets
- Full range of performance matched work tools
 - Auger, hammer, shear, ripper

LIGHTS AND MIRRORS

- Mirror, cab rear

SAFETY AND SECURITY

- Battery disconnect
- Front wire mesh guard
- Front steel plate guard
- Rain guard

TECHNOLOGY

- Product Link™

OTHER ATTACHMENTS

- Counterweight, extra, 1121 kg (2,493 lb)*

*Standard on VAB configuration.

For more complete information on Cat products, dealer services, and industry solutions, visit us on the web at www.cat.com

© 2017 Caterpillar
All rights reserved

Materials and specifications are subject to change without notice. Featured machines in photos may include additional equipment. See your Cat dealer for available options.

CAT, CATERPILLAR, SAFETY.CAT.COM, their respective logos, "Caterpillar Yellow" and the "Power Edge" trade dress, as well as corporate and product identity used herein, are trademarks of Caterpillar and may not be used without permission.

AEHQ7811-01 (07-2017)
Replaces AEHQ7811

