

953K WH, 963K WH, 973K WH



Waste Handler Track Loaders



Engine	953K		963K		973K	
Engine Model	Cat® C7.1 ACERT™		Cat C7.1 ACERT		Cat C9.3 ACERT	
Net Power (Rated)						
ISO 9249/SAE J1349	115 kW	154 hp	144 kW	193 hp	205 kW	275 hp
ISO 9249/SAE J1349 (DIN)		156 hp		196 hp		278 hp
Weights	953K		963K		973K	
Operating Weight	15 720 kg	34,656 lb	20 611 kg	45,439 lb	29 175 kg	64,319 lb

Waste Handler Track Loaders

Fuel Efficiency

More fuel efficient Cat engines with ACERT technology and Eco Mode combine to give you a 10-25 percent reduction in fuel use.*

Performance

Smarter power train management gives you power when you need it and improved implement and steering response.*

Ease of Operation

Cab updates offer added comfort and convenience for operators. New handles and steps make access/egress even easier from the front or the back of the tracks.

Technology

Remote monitoring with Product Link™/ VisionLink® helps you manage your fleet more effectively and profitably.

Note: Extreme Service model shown. Guarding and features may vary by machine model. Please consult your Cat dealer for details.

*Compared to previous models.



Contents

Durability	3
Performance	4
Maintenance.....	5
Safety	5
Specifications.....	6
Equipment Packages.....	10

From loading and sorting to excavation and spreading cover material, the track loader is one of the most versatile pieces of equipment in your landfill or transfer station. Waste Handler arrangements feature added guarding and seals to give you a purpose-built machine to take on the challenges of waste applications. A choice of buckets and track shoes allow you to further optimize the machine for greater performance and service life. The new Cat crawler loaders offer added fuel efficiency over the previous models, as well as greater comfort and improved implement and steering response.

Durability

Designed for performance



963K Extreme Service model shown.

- Final drives and idlers feature specialized protection against damage to seals caused by wire, plastic and other wrapping debris.
- Idler guards and scrapers protect and limit the entry of debris to the tensioning system.
- Engine compartment seals limit debris entry and plugging of radiator core; gaps sealed between sheet metal and other components for added protection.
- Guarding helps protect lift lines, lift cylinder hydraulic tube, bucket hydraulic lines and tilt cylinder from damage by falling debris.
- Laminated thermal shields and insulated clean emission module.* 973K also features thermal shield on turbo.
- Heavy duty rear bumper on Extreme Service package offers optimal protection to the back of the machine – especially the cooling system. Includes a heavy duty grill with latch for quick opening, as well as a hitch.
- Rear striker bars help keep trash from damaging the fenders and to help extend sheet metal life.

**Machines equipped with Tier 4 Final/Stage IV emissions reduction technology.*



Ease of Operation

- Specialized air handling features deliver cleaner air to the machine and cab.
- Updated cab gives operators added comforts like adjustable armrests and controls, improved air conditioning system and a heated/ventilated seat option.
- Electro-Hydraulic Implement Controls provide responsive, smooth and precise control of bucket and lift arms.
- Excellent visibility to the bucket and all around the machine helps operators work more confidently, especially in tight spaces.
- Reduced engine noise* makes the environment quieter for the operator and others around the worksite.

**Compared to previous models.*

Performance

Power and efficiency



963K Extreme Service model shown.

- The more efficient engine and an Eco Mode combine to deliver a 10-25 percent reduction in fuel consumption compared to the D Series models.
- Center-hole track helps reduce packing. Choose from a variety of shoe types and widths to optimize the loader for your application.
- Double Grouser Shoes provide good balance of traction and a smooth ride. Recommended for reduced damage when working on concrete.
- Single Grouser Track is aggressive for good chopping action and the best traction in poor underfoot conditions.
- Landfill bucket equipped with heavy-duty trash rack to increase bucket capacity, reduce spillage, and help protect tilt cylinder rod.
- Quick coupler option adds versatility with easy use of forks, buckets and other attachments from compatible machines.
- Optional eight-light LED package illuminates work area with four lights at top front corner of windshield and four on air conditioning compressor guard.
- Smarter power train management gives you power when you need it and improved implement and steering response.
- A hydraulic demand fan reduces speed in cooler conditions to conserve power, save fuel and decrease sound levels.

Extreme Service Package

- Extreme Service package provides even more guarding to equip the machine for tougher work like demolition and transfer station.
- Available on 963K and 973K models.

Maintenance

When uptime counts

- Turbine precleaner reduces particles coming into the engine air inlet for extended engine filter life.
- Cooling system is specially designed for high debris environments.
- Reversing fan helps limit radiator plugging and increase maintenance interval.
- Cooling system access from the engine compartment with fold-down fan (953/963 models) for easy clean-out.
- Grouped service points located behind large access doors; daily grease points in easy reach at ground level.
- Handy bracket holds a shovel for quick undercarriage clean-out.
- Tilt cab allows easy access to drive train and hydraulic systems.
- Cab-mounted heating/ventilation/air conditioning (HVAC) system gives you more cooling capability, and removes the condenser from under the hood for reduced heat and easier service.

Enhanced Cleaning Package

- Faster, easier cleanout.
- Wide gauge undercarriage equipped with a standard track shoe allows more space for debris to pass between the track roller frame, tracks and chassis.
- Design helps reduce damage caused by debris carried on the tracks.
- Heavier waste configuration combined with narrower track shoes increases ground pressure for greater compaction.



Safety

Designed with protection in mind

- Bars help protect windshield and operator from breakage and debris. New cab door guards offer added protection.
- Rear vision camera** enhances visibility behind the machine.
- New handles and steps help operators climb on and off the machine more easily, from the front or the back of the tracks.
- Excellent visibility to the bucket and all around the machine helps operators work more confidently.

***Not available in all areas. Please consult your Cat dealer for details.*

Waste Handler Track Loaders Specifications

Engine						
	953K		963K		973K	
Engine Model	Cat C7.1 ACERT		Cat C7.1 ACERT		Cat C9.3 ACERT	
Emissions	U.S. EPA Tier 4 Final/EU Stage IV/Korea Tier 4 or China Nonroad Stage III, India Bharat III, Eurasian Economic Union Stage IIIA UN ECE R96 Stage IIIA emission standards, equivalent to Tier 3/Stage IIIA				Tier 4 Final/EU Stage IV/Korea Tier 4	
Engine Power (Maximum)						
SAE J1995	132 kW	177 hp	168 kW	225 hp	231 kW	310 hp
ISO 14396	129 kW	173 hp	165 kW	221 hp	228 kW	306 hp
ISO 14396 (DIN)		175 hp		224 hp		310 hp
Net Power (Rated)						
ISO 9249/SAE J1349	115 kW	154 hp	144 kW	193 hp	205 kW	275 hp
ISO 9249/SAE J1349 (DIN)		156 hp		196 hp		278 hp
Bore	105 mm	4.13 in	105 mm	4.13 in	115 mm	4.5 in
Stroke	135 mm	5.31 in	135 mm	5.31 in	149 mm	5.9 in
Displacement	7.01 L	427.8 in ³	7.01 L	427.8 in ³	9.3 L	567 in ³

- Engine ratings at 1,800 rpm.
- All nonroad Tier 4 Interim and Final, Stage IIIB and IV and Korea Tier 4 diesel engines are required to use only Ultra Low Sulfur Diesel (ULSD) with 15 ppm (mg/kg) of sulfur or less, or up to B20 biodiesel blended with ULSD. B20 should meet ASTM D7467 specification (biodiesel blend stock should meet Cat biodiesel spec, ASTM D6751 or EN 14214). Cat DEO-ULS™ or oils that meet the Cat ECF-3, API CJ-4, and ACEA E9 specification are required. Consult your OMM for further machine specific fuel recommendations.
- Diesel Exhaust Fluid (DEF) used in Cat Selective Catalytic Reduction (SCR) systems must meet the requirements outlined in the International Organization for Standardization (ISO) standard 22241.

Service Refill Capacities						
	953K		963K		973K	
Fuel Tank	265 L	70 gal	320 L	84.5 gal	384 L	101.5 gal
Cooling System	32 L	8.45 gal	32 L	8.45 gal	44 L	11.6 gal
DEF Tank	16 L	4.22 gal	16 L	4.22 gal	35 L	9.2 gal

Weights – Waste Handler						
	953K		963K		973K	
Operating Weight*	15 720 kg	34,656 lb	20 611 kg	45,439 lb	29 175 kg	64,319 lb
Operating Weight	15 433 kg	34,024 lb	20 322 kg	44,802 lb	—	—
Shipping Weight*	14 455 kg	31,867 lb	18 572 kg	40,944 lb	26 710 kg	58,884 lb
Shipping Weight	14 168 kg	31,235 lb	18 285 kg	40,311 lb	—	—

*Machine equipped with Tier 4 Final/Stage IV emissions reduction technology.

Waste Handler Track Loaders Specifications

Buckets

	953K				963K				973K			
	Capacity		Width		Capacity		Width		Capacity		Width	
General Purpose	1.8 m ³	2.4 yd ³	2485 mm	97.8 in	2.5 m ³	3.2 yd ³	2612 mm	102.8 in	3.2 m ³	4.2 yd ³	2974 mm	117 in
Performance Series	2.1 m ³	2.7 yd ³	2536 mm	99.8 in	2.8 m ³	3.7 yd ³	2712 mm	106.8 in	3.8 m ³	5.0 yd ³	2982 mm	117 in
Multi-Purpose	1.6 m ³	2.1 yd ³	2471 mm	97.3 in	2.0 m ³	2.6 yd ³	2575 mm	101.3 in	3.0 m ³	4.0 yd ³	2946 mm	116 in
Landfill	2.3 m ³	3.0 yd ³	2485 mm	97.8 in	3.1 m ³	4.1 yd ³	2612 mm	102.8 in	4.9 m ³	6.4 yd ³	2974 mm	117 in

- Bucket equipped with teeth and segments.

Undercarriage

	953K		963K		973K	
Track Shoe Type	Double Grouser		Double Grouser		Double Grouser	
Track Shoe Width – Standard Shoe/Center Hole	480 mm	19 in	550 mm	22 in	550 mm	22 in
Track Rollers/Shoes – Each Side	6/37		7/38		7/40	
Track on Ground	2320 mm	91.3 in	2542 mm	100 in	2930 mm	115.3 in
Ground Contact Area – Standard Shoe/Center Hole	2.2 m ²	3.41 in ²	3.2 m ²	4,900 in ²	3.66 m ²	5,673 in ²
Ground Pressure* – Standard Shoe/Center Hole**	60.7 kPa	8.8 psi	62.9 kPa	9.1 psi	77.6 kPa	11.3 psi
Ground Pressure – Standard Shoe/Center Hole**	59.6 kPa	8.6 psi	62.0 kPa	9.0 psi	—	—
Grouser Height	35 mm	1.4 in	42 mm	1.65 in	49 mm	1.9 in
Track Gauge	1836 mm	72.3 in	1850 mm	72.8 in	2160 mm	85 in
Link Pitch	190 mm	7.48 in	202.8 mm	8.0 in	215.9 mm	8.5 in

*Machine equipped with Tier 4 Final/Stage IV emissions reduction technology.

**ISO 16754:2008.

- Ground pressure is calculated using operating weight of machine with General Purpose bucket, teeth and segments.

Waste Handler Track Loaders Specifications

Standards

ROPS/FOPS	<ul style="list-style-type: none">• ROPS (Rollover Protective Structure) offered by Caterpillar for the machine meets ROPS criteria ISO 3471:2008.• FOPS (Falling Object Protective Structure) meets ISO 3449-2005 Level II.
-----------	---

Brakes	<ul style="list-style-type: none">• Brakes meet the standard ISO 10265:2008.
--------	--

Sound and Vibration Information

- The declared dynamic operator sound pressure level when “ISO 6396:2008” is used to measure the value for an enclosed cab. The measurements were conducted at the maximum engine cooling fan speed for 953K and 963K, and for 80 percent of the maximum engine cooling fan speed for 973K. The sound level may vary at different engine cooling fan speeds. The cab was properly installed and maintained. The measurements were conducted with the cab doors and the cab windows closed.

NOTE: The dynamic operator sound pressure level uncertainty is ± 2 dB(A).

953K	73 dB(A)
963K	74 dB(A)
973K	75 dB(A)

- Hearing protection may be needed when the machine is operated with an open operator station for extended periods, in a noisy environment or with a cab that is not properly maintained.
- The guaranteed exterior sound power level is measured according to the dynamic test procedures and the conditions that are specified in “ISO 6395:2008.” The measurements were conducted at the maximum engine cooling fan speed for 953K and 963K, and for 80 percent of the maximum engine cooling fan speed for 973K. The sound level may vary at different engine cooling fan speeds.

953K	109 dB(A)
963K	111 dB(A)
973K	111 dB(A)

- Sound Level Information for Machines in European Union Countries and in Countries that Adopt the “EU Directives:” The declared dynamic operator sound pressure level when “ISO 6396:2008” is used to measure the value for an enclosed cab. The measurements were conducted at the maximum engine cooling fan speed for 953K and 963K, and for 80 percent of the maximum engine cooling fan speed for 973K. The sound level may vary at different engine cooling fan speeds. The cab was properly installed and maintained. The measurements were conducted with the cab doors and the cab windows closed.

NOTE: The dynamic operator sound pressure level uncertainty is ± 2 dB(A).

953K	71 dB(A)
963K	73 dB(A)
973K	75 dB(A)

- If equipped, the certification label is used to verify the environmental sound certification of the machine to the requirements of the European Union. The value that is listed on the label indicates the guaranteed exterior sound power level (L_{WA}) at the time of manufacture for the conditions that are specified in “2000/14/EC.”

Air Conditioning System

953K/963K

The air conditioning system on this machine contains the fluorinated greenhouse gas refrigerant R134a (Global Warming Potential = 1430). The system contains 1.1 kg of refrigerant which has a CO₂ equivalent of 1.573 metric tonnes.

973K

The air conditioning system on this machine contains the fluorinated greenhouse gas refrigerant R134a (Global Warming Potential = 1430). The system contains 1.9 kg of refrigerant which has a CO₂ equivalent of 2.717 metric tonnes.

For complete machine specifications, operating specifications and full Standard/Optional equipment, please reference machine product brochures for the 953K/963K (AEHQ8061) and 973K (AEHQ8065) Track Loaders. The information is available from your Cat dealer, or download by visiting www.cat.com.

Waste Handler Track Loaders Specifications

Dimensions

All dimensions are approximate.

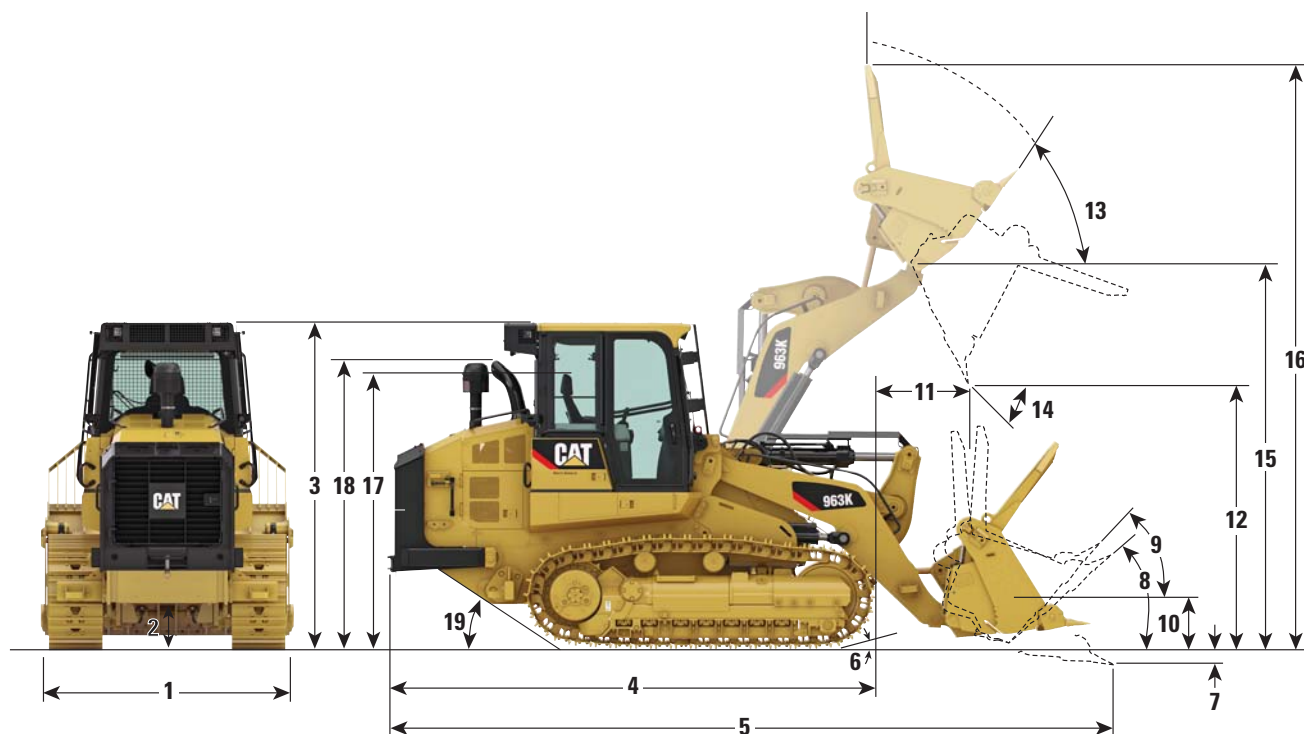

953K 963K 973K

	953K	963K	973K
1 Overall Machine Width without Bucket:			
With Standard Tracks – 480 mm (19.7 in) Shoes	2316 mm	91.2 in	2400 mm
With Wide Gauge Tracks – 800 mm (31.5 in) Shoes	2936 mm	115.6 in	2900 mm
2 Ground Clearance	417 mm	16.4 in	471 mm
3 Machine Height to Top of Cab	3155 mm	124.2 in	3325 mm
4 Length to Front of Track	4545 mm	178.9 in	4943 mm
5 Overall Machine Length*	6389 mm	251.5 in	7001 mm
6 Carry Position Approach Angle	15°	15°	15°
7 Digging Depth*	140 mm	5.5 in	138 mm
8 Maximum Rollback at Ground	43°	43°	43°
9 Maximum Rollback at Carry Position	50°	50°	47°
10 Bucket Height in Carry Position	548 mm	21.6 in	457 mm
11 Reach at Full Lift Height and 45° Dump*	1195 mm	47.0 in	1373 mm
12 Clearance at Full Lift Height and 45° Dump*	2694 mm	106.0 in	2915 mm
13 Maximum Rollback, Fully Raised	52°	52°	59°
14 Maximum Dump, Fully Raised	53°	53°	49°
Grading Angle	74°	63°	85°
15 Height to Bucket Hinge Pin	3610 mm	142.1 in	3940 mm
16 Overall Machine Height, Bucket Fully Raised	5487 mm	216.0 in	5885 mm
17 Height to Top of Seat with Headrest	2596 mm	102.2 in	2808 mm
18 Height to Top of Stack	2804 mm	110.3 in	2940 mm
19 Ramp Angle	29°	29°	29°

* With general purpose bucket and extra duty teeth.

Dimensions vary with bucket. Refer to Operating Specifications chart.

Waste Handler Track Loaders Equipment Packages

Equipment Packages

Equipment packages may vary. Consult your Cat dealer for details.

WASTE HANDLER – HEAVY DUTY

953K Includes:

- Heavy Duty Undercarriage
- Final Drive/Idler/Duo Cone Seal Guards
- Sealing Between Front Guard and Frame Around Hydraulic Lines
- Rear Guard/Fan Door Latches

Requires:

- Turbine Precleaner on Engine Air Inlet
- Idler Guard
- Reversing Demand Fan
- Heavy Duty Tracks with Center Hole

Recommended Options:

- Striker Bars
- Landfill Bucket
- Cab Air Precleaner
- Rear Counterweight (when equipped with Landfill or Multi-Purpose bucket)
- Extended Service Package
- Windshield Protection

963K Includes:

- Heavy Duty Undercarriage
- Final Drive/Idler/Duo Cone Seal Guards
- Sealing Between Front Guard and Frame Around Hydraulic Lines
- Rear Guard/Fan Door Latches
- Heavier Front Guard for the Hydraulic Tank

Requires:

- Turbine Precleaner on Engine Air Inlet
- Idler Guard
- Reversing Demand Fan
- Heavy Duty Tracks
- Lift Cylinder Guard
- Extended Service Package
- Windshield Protection

Recommended Options:

- Rear Striker Bars
- Tracks with Center Hole
- Cab Air Precleaner
- Final Drive Abrasion Guard (two- or three-piece)
- Tilt Cylinder Guard

973K Includes:

- Final Drive/Idler/Duo Cone Seal Guards
- Lower Final Drive Abrasion Guard

Requires:

- Engine Thermo Shield
- Reversing Fan
- Turbine Precleaner on Engine Air Inlet
- Heavy Duty Tracks
- Visibility Kit, Double Camera
- Extended Service Package
- Windshield Protection

Recommended Options:

- Tracks With Center Hole
- Cab Air Precleaner
- Tilt Cylinder Guard
- Final Drive Abrasion Guard
- Rear Striker Bars

Continued on next page

Waste Handler Track Loaders Equipment Packages

Equipment Packages (continued)

Equipment packages may vary. Consult your Cat dealer for details.

ENHANCED CLEANING PACKAGE

953K Includes:

- Wide Gauge Undercarriage
- Standard Width Shoes

Requires:

- Heavy Duty Center Hole Tracks with 480 mm/19 in Maximum Width Shoes
- Turbine Precleaner on Engine Air Inlet
- Idler Guard
- Reversing Demand Fan
- Extended Service Package
- Bucket with 2620 mm/103.2 in Minimum Width (or no bucket)
- Cab Air Precleaner
- Windshield Protection

Recommended Options:

- Striker Bars and/or Counterweight

963K Includes:

- Wide Gauge Undercarriage
- Standard Width Shoes

Requires:

- Turbine Precleaner on Engine Air Inlet
- Idler Guard
- Reversing Demand Fan
- Heavy Duty Tracks
- Lift Cylinder Guard
- Extended Service Package
- Windshield Protection
- Cab Air Precleaner
- Wide Flush Bucket

Recommended Options:

- Striker Bars and/or Counterweight
- Tilt Cylinder Guard
- Final Drive Abrasion Guard (two- or three-piece)
- Full Length Heavy Duty Track Guard
- Tracks With Center Hole

973K Includes:

- Wide Gauge Undercarriage
- Standard Width Shoes
- Lower Final Drive Abrasion Guard

Requires:

- Engine Thermo Shield
- Reversing Fan
- Turbine Precleaner on Engine Air Inlet
- Heavy Duty Tracks
- Visibility Kit, Double Camera
- Extended Service Package
- Cab Air Precleaner
- Windshield Protection

Recommended Options:

- Center Hole Tracks with 500 mm/19.7 in or 675 mm/26.6 in Maximum Width Shoes
- Tilt Cylinder Guard
- Final Drive Abrasion Guard
- Track Roller Guard
- Striker Bars and/or Counterweight

EXTREME SERVICE PACKAGE

963K Includes Waste Handler Package Plus:

- Heavy Duty Bumper with Hitch
- Lift Cylinder Guards
- Tilt Cylinder Guard
- Striker Bars

Requires:

- Idler Guard
- Turbine Precleaner on Engine Air Inlet
- Reversing Demand Fan
- Extended Service Package
- No Bumper
- Heavy Duty Tracks
- Cab Air Precleaner
- Windshield Protection

Recommended Options:

- Tracks With Center Hole
- Landfill or Multi-Purpose Bucket
- Full-length Heavy Duty Track Guard
- Final Drive Abrasion Guard (two- or three-piece)

973K Includes Waste Handler Package Plus:

- Heavy Duty Bumper with Hitch
- Lift Cylinder Guards
- Tilt Cylinder Guard
- Striker Bars
- Windshield Protection
- Final Drive Abrasion Guard
- Lower Final Drive Abrasion Guard
- Rear Striker Bars

Requires:

- Engine Thermo Shield
- Reversing Fan
- Turbine Precleaner on Engine Air Inlet
- Heavy Duty Tracks
- Visibility Kit, Double Camera
- Extended Service Package
- No Bumper
- Cab Air Precleaner
- Rear Step, Ripper

Recommended Options:

- Tracks with Center Hole
- Landfill or Multi-Purpose Bucket
- Track Roller Guard

Features vary by model. For more information about standard and optional equipment for each model, and to equip a machine to best meet your waste handling needs, please consult with your Cat dealer.

For more complete information on Cat products, dealer services, and industry solutions, visit us on the web at www.cat.com

© 2017 Caterpillar
All rights reserved

Materials and specifications are subject to change without notice. Featured machines in photos may include additional equipment. See your Cat dealer for available options.

CAT, CATERPILLAR, SAFETY.CAT.COM, their respective logos, "Caterpillar Yellow" and the "Power Edge" trade dress, as well as corporate and product identity used herein, are trademarks of Caterpillar and may not be used without permission.

VisionLink is a trademark of Trimble Navigation Limited, registered in the United States and in other countries.

AEHQ7647-01 (12-2017)
Replaces AEHQ7647
(Global excluding Japan)

