

# Modular Acoustic Enclosures

455 – 750 kVA Range



[www.FGWilson.com](http://www.FGWilson.com)



The innovative and functional design of the 455 – 750 kVA enclosure range ensures performance in the harshest of environments. Extremely durable and robust, the enclosures are designed to resist corrosion and handling damage with the ability to withstand rough handling common on many construction sites.

Developed through continuing research and development by our specialist engineers, all FG Wilson enclosures are weather resistant and incorporate internally mounted exhaust silencers. Designed on modular principles, they have interchangeable components permitting on site repair.

The CAE enclosures reduce sound levels to comply with stage II levels of the European Community Directive 2000/14/EC which became effective 3 January 2006.

The FG Wilson CAHA enclosures, also available across the entire 455 – 750 kVA range are designed for operation in high ambient environments up to 50°C, with no loss of cooling system performance.

### Excellent Access for Maintenance

- » Large side hinged doors on both sides of enclosure providing optimal access
- » Retaining bars securing door positions during servicing
- » Removable ducts providing maintenance access with enclosure in place
- » Radiator fill via removable, flush mounted rain cap fitted with compression seal
- » Lube oil and coolant drain valves

### Robust/Highly Corrosion Resistant Construction

- » Galvanised steel construction further protected by polyester powder coat paint
- » Base frame extends beyond enclosure protecting against handling damage
- » Reinforced lap roof joints protecting against water ingress
- » Black finish stainless steel locks and hinges
- » Zinc plated / stainless steel fasteners
- » Corner posts manufactured from high grade composite material



### Transportability

- » Optional tested and certified lifting arch (excluding 2806)
- » Lifting, drag and jacking points on base frame

### Security and Safety

- » Control panel viewing window in a lockable access door
- » Emergency stop push button (red) mounted on enclosure exterior
- » Cooling fan and battery charging alternator fully guarded
- » Fuel fill and battery can only be reached via lockable access doors
- » Exhaust silencing system totally enclosed for operator safety

## Sound Pressure Levels (dBA) - CAHA

Generator Set Model		50 Hz								60 Hz							
		15 m (50 ft)		7 m (23 ft)		1 m (3 ft)		1.5 m (4.5 ft)		15 m (50 ft)		7 m (23 ft)		1 m (3 ft)		1.5 m (4.5 ft)	
		75% Load	100% Load	75% Load	100% Load	75% Load	100% Load	75% Load	100% Load	75% Load	100% Load	75% Load	100% Load	75% Load	100% Load	75% Load	100% Load
P500-5	Prime	71	72	77	78	86	86	84	84	-	-	-	-	-	-	-	-
	Standby	71	72	77	78	86	86	84	84	-	-	-	-	-	-	-	-
P550-5	Prime	71	72	77	78	86	86	84	84	-	-	-	-	-	-	-	-
	Standby	71	72	77	78	86	86	84	84	-	-	-	-	-	-	-	-
P563-5	Prime	-	-	-	-	-	-	-	-	73	74	79	80	87	88	85	86
	Standby	-	-	-	-	-	-	-	-	73	74	79	80	87	88	85	86
P605-5	Prime	70	71	76	77	84	85	82	83	-	-	-	-	-	-	-	-
	Standby	70	72	76	78	84	85	82	83	-	-	-	-	-	-	-	-
P625-5	Prime	-	-	-	-	-	-	-	-	73	74	79	80	87	88	85	86
	Standby	-	-	-	-	-	-	-	-	73	74	79	80	87	88	85	86
P660-5	Prime	70	72	76	78	84	85	82	83	-	-	-	-	-	-	-	-
	Standby	71	72	77	78	85	86	83	84	-	-	-	-	-	-	-	-
P688-5	Prime	-	-	-	-	-	-	-	-	72	72	78	78	87	88	85	86
	Standby	-	-	-	-	-	-	-	-	72	73	78	79	88	88	85	86
P700-5	Prime	71	72	77	78	84	85	83	84	-	-	-	-	-	-	-	-
	Standby	71	72	77	78	85	86	83	84	-	-	-	-	-	-	-	-
P750-5	Prime	-	-	-	-	-	-	-	-	72	73	78	79	88	88	85	86
	Standby	-	-	-	-	-	-	-	-	72	73	78	79	88	88	85	86

## CAHA High Ambient Enclosure

### Ambient Capability\*

Generator Set Model	Engine Model	50 Hz		60 Hz	
		°C	°F	°C	°F
P500-5	2506A-E15TAG1	55	131	-	-
P550-5	2506A-E15TAG2	52	126	-	-
P563-5	2506A-E15TAG3	-	-	55	136
P605-5	2806A-E18TAG1	55	133	-	-
P625-5	2506A-E15TAG4	-	-	54	129
P660-5	2806A-E18TAG1A	54	129	-	-
P688-5	2806A-E18TAG1A	-	-	55	133
P700-5	2806A-E18TAG2	52	126	-	-
P750-5	2806A-E18TAG3	-	-	53	127

\*Designed for operation in high ambient environments up to 50°C with no loss of cooling system performance. Power output derate will apply.

## Sound Pressure Levels (dBA) - CAE

Generator Set Model		50 Hz								60 Hz							
		15 m (50 ft)		7 m (23 ft)		1 m (3 ft)		1.5 m (4.5 ft)		15 m (50 ft)		7 m (23 ft)		1 m (3 ft)		1.5 m (4.5 ft)	
		75% Load	100% Load	75% Load	100% Load	75% Load	100% Load	75% Load	100% Load	75% Load	100% Load	75% Load	100% Load	75% Load	100% Load	75% Load	100% Load
P500-5	Prime	63	64	69	70	79	79	76	77	-	-	-	-	-	-	-	-
	Standby	63	64	69	70	79	80	77	78	-	-	-	-	-	-	-	-
P550-5	Prime	63	64	69	70	79	80	77	78	-	-	-	-	-	-	-	-
	Standby	64	65	70	71	79	80	77	78	-	-	-	-	-	-	-	-
P563-5	Prime	-	-	-	-	-	-	-	-	65	66	71	72	81	82	79	80
	Standby	-	-	-	-	-	-	-	-	65	67	71	73	82	83	79	81
P605-5	Prime	66	66	72	72	82	82	79	80	-	-	-	-	-	-	-	-
	Standby	66	66	72	72	82	83	79	80	-	-	-	-	-	-	-	-
P625-5	Prime	-	-	-	-	-	-	-	-	65	67	71	73	82	83	79	81
	Standby	-	-	-	-	-	-	-	-	66	67	72	73	82	83	80	81
P660-5	Prime	66	66	72	72	82	83	79	80	-	-	-	-	-	-	-	-
	Standby	66	67	72	73	82	83	80	80	-	-	-	-	-	-	-	-
P688-5	Prime	-	-	-	-	-	-	-	-	67	68	73	74	84	84	81	82
	Standby	-	-	-	-	-	-	-	-	67	68	73	74	84	84	81	82
P700-5	Prime	66	67	72	73	82	83	80	80	-	-	-	-	-	-	-	-
	Standby	66	67	72	73	82	83	80	80	-	-	-	-	-	-	-	-
P750-5	Prime	-	-	-	-	-	-	-	-	67	68	73	74	84	84	81	82
	Standby	-	-	-	-	-	-	-	-	67	68	73	74	84	84	82	82

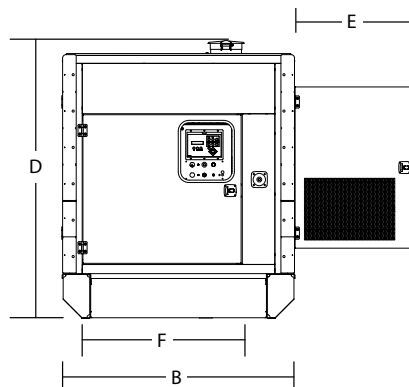
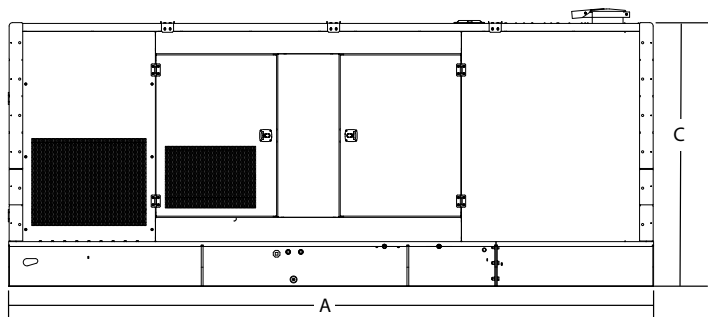

## Dimensions and Weights – CAHA

Generator Set Model	A: mm (in)	B: mm (in)	C: mm (in)	D: mm (in)	E: mm (in)*	F: mm (in)	Weight: kg (lb)	Fuel Tank Fillable Capacity I (US gal)
P500-5	4930 (194.1)	1658 (65.3)	2147 (84.5)	2317 (91.2)	995 (39.2)	1236 (48.7)	5147 (10289)	887 (234)
P550-5	4930 (194.1)	1658 (65.3)	2147 (84.5)	2317 (91.2)	995 (39.2)	1236 (48.7)	5197 (11457)	887 (234)
P563-5	4930 (194.1)	1658 (65.3)	2147 (84.5)	2317 (91.2)	995 (39.2)	1236 (48.7)	4970 (10957)	887 (234)
P605-5	5320 (209.4)	1920 (75.6)	2177 (85.7)	2289 (90.1)	995 (39.2)	1305 (51.4)	5514 (11257)	1157 (306)
P625-5	4930 (194.1)	1658 (65.3)	2147 (84.5)	2317 (91.2)	995 (39.2)	1236 (48.7)	4970 (10957)	887 (234)
P660-5	5320 (209.4)	1920 (75.6)	2177 (85.7)	2289 (90.1)	995 (39.2)	1305 (51.4)	5534 (11530)	1157 (306)
P688-5	5320 (209.4)	1920 (75.6)	2177 (85.7)	2289 (90.1)	995 (39.2)	1305 (51.4)	5403 (11912)	1157 (306)
P700-5	5320 (209.4)	1920 (75.6)	2177 (85.7)	2289 (90.1)	995 (39.2)	1305 (51.4)	5534 (12200)	1157 (306)
P750-5	5320 (209.4)	1920 (75.6)	2177 (85.7)	2289 (90.1)	995 (39.2)	1305 (51.4)	5454 (12024)	1157 (306)

Weight with lube oil and coolant, no fuel.

\*Clearance required on both sides.

## Dimensions and Weights – CAE

Generator Set Model	A: mm (in)	B: mm (in)	C: mm (in)	D: mm (in)	E: mm (in)*	F: mm (in)	Weight: kg (lb)	Fuel Tank Fillable Capacity I (US gal)
P500-5	4930 (194.1)	1658 (65.3)	2147 (84.5)	2317 (91.2)	995 (39.2)	1236 (48.7)	5147 (10289)	887 (234)
P550-5	4930 (194.1)	1658 (65.3)	2147 (84.5)	2317 (91.2)	995 (39.2)	1236 (48.7)	5197 (11457)	887 (234)
P563-5	4930 (194.1)	1658 (65.3)	2147 (84.5)	2317 (91.2)	995 (39.2)	1236 (48.7)	4970 (10957)	887 (234)
P605-5	5320 (209.4)	1920 (75.6)	2177 (85.7)	2289 (90.1)	995 (39.2)	1305 (51.3)	5514 (11257)	1157 (306)
P625-5	4930 (194.1)	1658 (65.3)	2147 (84.5)	2317 (91.2)	995 (39.2)	1236 (48.7)	4970 (10957)	887 (234)
P660-5	5320 (209.4)	1920 (75.6)	2177 (85.7)	2289 (90.1)	995 (39.2)	1305 (51.3)	5534 (11530)	1157 (306)
P688-5	5320 (209.4)	1920 (75.6)	2177 (85.7)	2289 (90.1)	995 (39.2)	1305 (51.3)	5403 (11912)	1157 (306)
P700-5	5320 (209.4)	1920 (75.6)	2177 (85.7)	2289 (90.1)	995 (39.2)	1305 (51.3)	5534 (12200)	1157 (306)
P750-5	5320 (209.4)	1920 (75.6)	2177 (85.7)	2289 (90.1)	995 (39.2)	1305 (51.3)	5454 (12024)	1157 (306)

Weight with lube oil and coolant, no fuel.

\*Clearance required on both sides.

## FG Wilson manufactures product in the following locations:

Northern Ireland • Brazil • China • India • USA

With headquarters in Northern Ireland, FG Wilson operates through a Global Dealer Network.

To contact your local Sales Office please visit the FG Wilson website at [www.FGWilson.com](http://www.FGWilson.com).

FG Wilson is a trading name of Caterpillar (NI) Limited.

In line with our policy of continuous product development, we reserve the right to change specification without notice.

455-750kVAEnclosure/0516/GB