

# DO DC GENERATORS OFFER FUEL ECONOMY ADVANTAGES OVER AC GENERATORS?

ANSWERS FOR THE TELECOM INDUSTRY

**Marcelo Algrain, Ph.D.**

Engineering Technical Steward

Electric Power Division

July 2017

**CATERPILLAR®**

# ABSTRACT

The purpose of this paper is to explain perceived differences in fuel consumption between AC and DC generator sets used in telecommunication (telecom) applications. A review of the overall energy conversion process, from energy in the fuel to electricity consumed by the load, is presented to account for losses in both AC and DC generator systems, and to explain

potential differences in fuel economy between the two systems. Fuel consumption test results are provided for four DC generator sets and one AC generator under identical loading conditions. An evaluation of the test data is presented, and conclusions are drawn on the validity of fuel savings claims by DC generators in small telecom applications.

# INTRODUCTION

There are many contributing factors to the total cost of operating an electric power generation system. Fuel consumption is one of them. In some applications, such as small, remotely located telecom sites, fuel consumption can be a significant portion of the overall operating cost. Recently, DC generators have been identified as providing significant fuel economy advantages over AC generators in certain telecom applications. This paper scrutinizes the validity of such claims.

The debate on AC versus DC has been around since the days of Edison (DC) and Tesla (AC).

Predominantly, it has been in the context of transmission and distribution of electricity, but it is now surfacing in other areas such as Uninterruptible Power Supply (UPS) systems, and most recently in power generation for telecom applications.

Although several very high-voltage DC transmission lines exist, as well as niche markets for DC UPS systems, it is undeniable that AC systems are the preferred choice for almost any kind of electric power system. So, what is behind the recent exuberance on DC generators for telecom applications? The core issue is fuel consumption. Do engine-driven DC generators really save

fuel over their AC counterparts? Some claim fuel consumption could be cut by more than one-half. How could this be possible?

To save fuel, a DC generator would need to be more efficient than an AC generator. If it were to cut fuel consumption by one-half, it would need to be twice as efficient as an AC generator. By and large, the efficiency of a 10 kVA AC synchronous generator is typically in the range of 80 to 95 percent (from worst-in-class to best-in-class). To cut fuel consumption by 50 percent over an AC generator, a DC generator would need to be 160 to 190 percent efficient. Obviously this could not be the case as efficiencies over 100 percent are unattainable. What then, is really behind the perceived fuel savings on a DC generator set?

To delve further into the fuel savings issue, let us consider the total amount of energy involved when one liter of diesel fuel is consumed to power a DC load. Figure 1 shows a schematic representation of an AC generator set comprised of a diesel engine and an AC synchronous generator, powering a DC load through an AC to DC rectifier. The thermal efficiency of a diesel engine, operating at peak fuel economy conditions, would be around 40 percent.

Likewise, the efficiency of an AC synchronous generator would be about 90 percent, and a good rectifier would be around 95 percent efficient. The typical net heating value of No. 2 diesel fuel is approximately 130,000 BTU per gallon, or 36 million Joule per liter, or 10 kWh per liter. If a diesel engine consumes one liter of fuel, it would produce approximately 4 kWh of

mechanical work, the AC generator would produce 3.6 kWh of electrical energy, and the rectifier would deliver 3.4 kWh of electricity to the DC load. (See Figure 1.) Thus, 3.4 kWh is the total amount of electrical energy consumed by the DC load after consuming one liter of diesel fuel in the AC generator set.

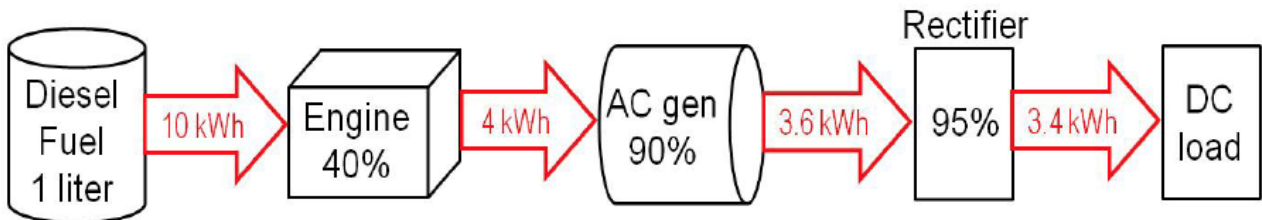

Figure 1: AC Generator Set Powering DC Loads

The question is, if the same load were to be powered by a DC generator set, how much fuel would be consumed? Some claim that a DC generator would cut fuel consumption in half. If that were to be the case, using the previous example, only one-half

liter of diesel fuel would be consumed instead of one liter. To validate or refute this claim, let us examine the overall energy conversion process in more detail by comparing the individual conversion steps in Figures 1 and 2.

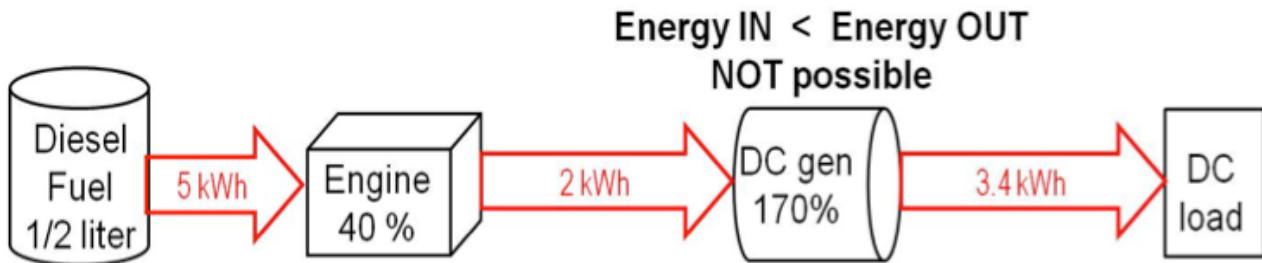

Figure 2: DC Generator Set Powering DC Loads

Figure 2 shows a schematic representation of a diesel engine driven DC generator set. The only difference between Figure 1 and Figure 2 is that the AC synchronous generator and rectifier have been replaced with a DC generator. If the fuel used by the DC generator set is only one-half of what its AC counterpart would use, only 5 kWh of energy would be available to the engine, and its mechanical output would be limited to 2 kWh.

However, to power the same DC load, a total of 3.4 kWh of electricity would be required from the DC generator. Then the electrical energy out of the DC generator would need to be 1.4 kWh higher than the 2.0 kWh of mechanical energy used to produce the electrical output.

It is well known that any energy conversion process that produces more energy than it consumes violates the Principle of Conservation of Energy. The DC generator would need to create energy, and its efficiency would need to be over 100 percent which is not possible.

Equivalently, if we think in terms of power instead of energy, because it is physically impossible for the output power to be higher than the input power, the science does not support the rhetoric being advanced by DC generator advocates in the telecom industry.

# FUEL CONSUMPTION TEST RESULTS

The preceding analysis demonstrated that DC generators by themselves cannot reduce fuel consumption by the amounts being claimed. However, credible organizations have reported large fuel savings when using DC systems. Furthermore, this subject has been at the forefront of discussions at premier telecom industry gatherings such as the GSMA World Congress.

There must be some validity to what is being reported. But what are the true root causes? To gather factual information and support it with hard data, Caterpillar engineers conducted comprehensive fuel consumption tests on four units marketed

as DC generator sets, and one additional unit comprised of an AC synchronous generator set and a full output AC to DC converter (rectifier) powering the same DC loads. The specifications of all five units are not identical, but collectively they are representative of market-leading choices suitable for application in small telecom sites. Figure 3 provides the fuel consumption test results for all five units. The data was normalized with respect to the fuel consumption of Unit 5 at a load of 10 kW (the 100 percent point).

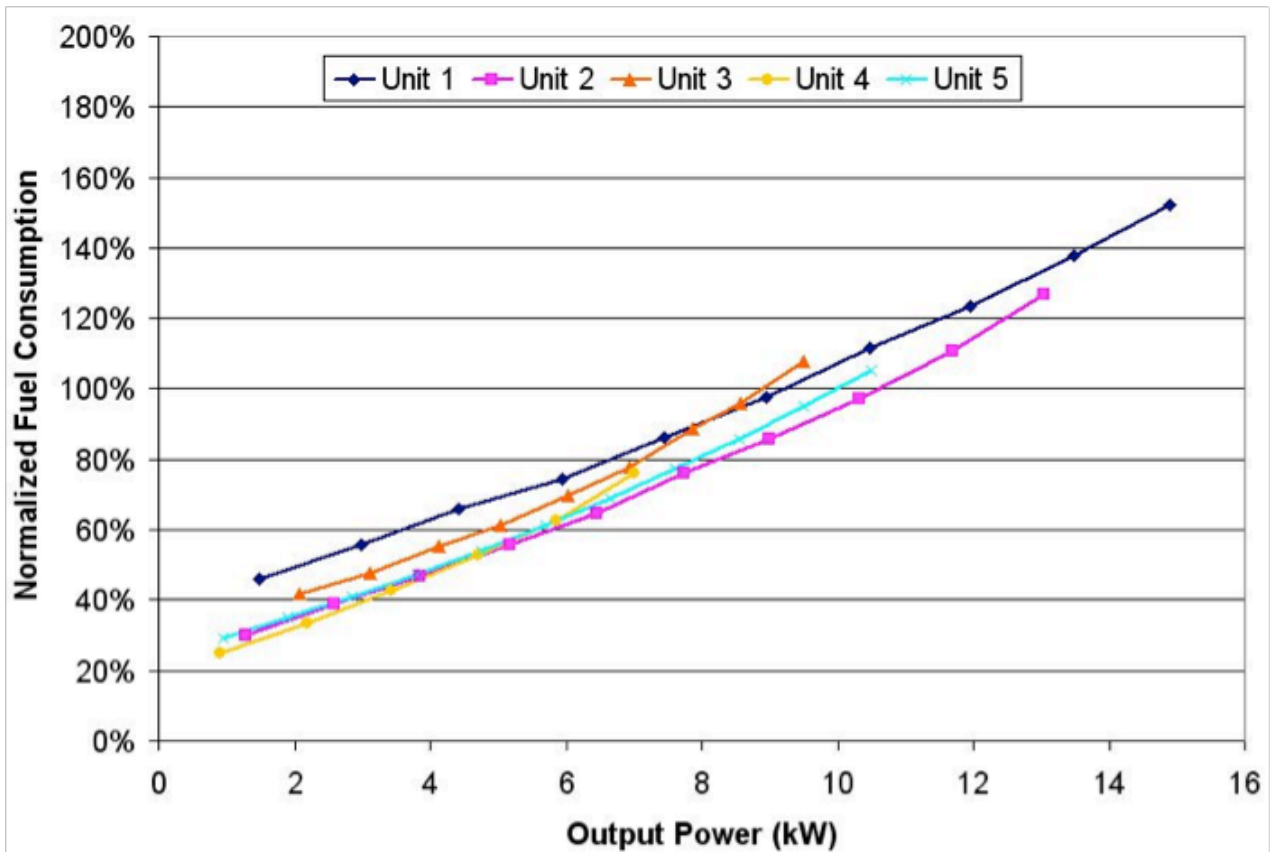

Figure 3: Fuel Consumption Test Results

Examining Figure 3, it is seen that most of the fuel consumption data points, for all units tested lie within a 15 to 20 percent wide band formed by the dark blue (◆) and the magenta (■) traces. These two traces correspond to the fuel consumption

of Units 1 and 2, respectively, which are both marketed as DC generator sets. The fuel consumption traces for Units 3, 4 and 5 (AC generator set included) are for the most part in close proximity to one another relative to the first two.

The data shows that there is a wider spread in the fuel consumption between two DC generator sets (Units 1 and 2) than there is between the AC generator set and all DC units, respectively. Hence, the differences in fuel consumption between all these units are not related to what type of generator set was used. There are also other factors at work.

Optimizing system components, such as engine selection, reducing parasitic losses through gains in cooling system efficiency, and overall system integration and controls, play a larger role in improving fuel economy than whether an AC or DC generator is used.

Good design would exploit the best attributes of either AC or DC technologies to develop a generator set that would optimize fuel consumption for a targeted application. This can be achieved with either technology. DC generators are not inherently more efficient than AC generators, and vice versa. The data provides solid evidence that the differences in fuel consumption between AC and DC generators are not significant. The reported large fuel savings attributed to DC generators remain unaccounted for.

## ACCOUNTING FOR PERCEIVED DIFFERENCES

The preceding section demonstrated that there are no significant differences in fuel consumption between AC and DC generator sets when powering the same constant load. However, the way generator sets are used in telecom applications varies. In areas where the grid connection is reliable, the total number of running hours is low and fuel consumption is generally not a concern. On the other hand, in off-grid applications, or where the grid is frequently unavailable for long periods of time, running hours can be very high and fuel consumption is a major issue.

In the later cases, telecom sites typically operate AC and DC generator sets in different modes. AC generator sets run continuously, or for the duration of extended outages. DC generator sets run intermittently. The reason DC systems can run intermittently while constantly powering the load is that they have batteries, which provide built-in energy storage. The batteries provide power to the load when the engine is not running. When it is time to recharge the batteries, the engine runs as needed, depending on the capacity of the battery pack.

In contrast, the AC generator set runs continuously. Could it be then that running an engine intermittently provides a fuel economy advantage over running it continuously? The answer would be obvious if they were producing the same amount of power while running, but that is not the case in a telecom application. The AC generator set running continuously would

operate at a lower power level than the DC generator set operating a few times a day. The total amount of electrical energy produced by the two would be the same over a one-day period, but the running power level would not be.

To illustrate this important point, let us consider an off-grid telecom site with a constant load of 1 kW, which this is representative of a small telecom site. The total amount of electricity consumed by the telecom equipment over a one-day period would be 24 kWh. Since the efficiencies of AC and DC generators are comparable, let us ignore the electrical losses on both and focus on the mechanical power required from the engine in each case.

For the DC generator set, let us further assume that it runs three times a day for one hour to recharge batteries. We will assume battery charging efficiency is 100 percent – a very idealized case but suitable for this comparison. Then, the engine on the DC generator set would run at an output power of 8 kW, three times a day, for one hour each time, to produce 24 kWh in a one-day period. In contrast, the engine on the AC generator set would run at a 1 kW output for 24 hours to power the telecom load. The typical rating of a diesel engine found at a small telecom site is around 10 kW. Thus, the engine load would only be 10 percent of its rated value in the AC generator case, and 80 percent in the DC generator case.

The question then becomes, would an engine loaded at 10 percent of its rating for 24 hours consume more fuel than the same engine loaded at 80 percent for three hours? To answer this question, one must review the Brake Specific Fuel Consumption (BSFC) curve as a function of engine load.

Figure 4 shows a normalized BSFC curve for a small diesel engine, with typical characteristics. The 100 percent BSFC

value corresponds to the best fuel economy point obtained at 80 percent load (see red circle). It is clear that when an engine is lightly loaded, its fuel consumption is significantly higher than when operating near its rated output. In our example, an AC generator set operating at a 10 percent power level would consume over twice as much fuel as a DC generator set operating at near peak fuel economy conditions.

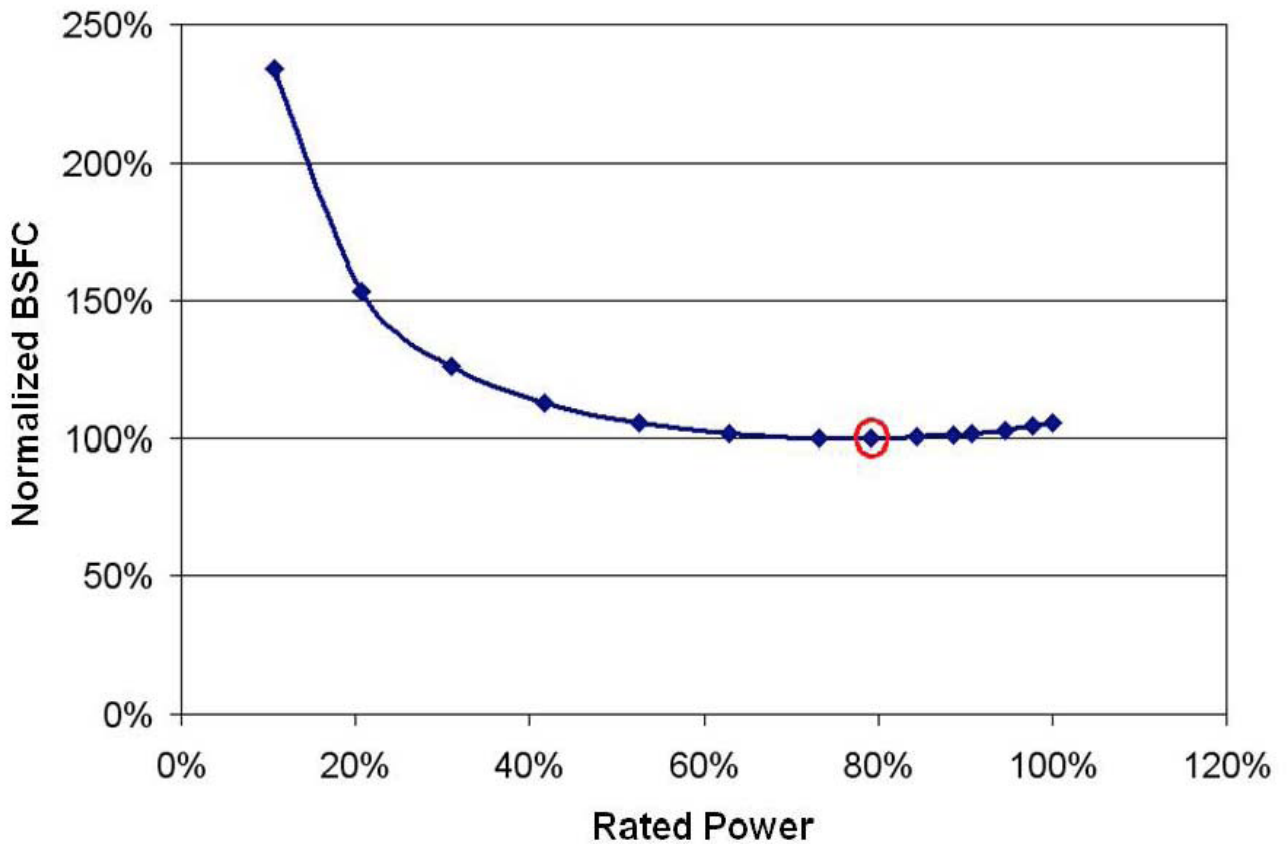

Figure 4: Normalized BSFC Curve for Typical Diesel Engine

Hence, the primary reason fuel savings have been reported in DC generator sets is that their engines, when run intermittently, operate at a much higher loading condition where fuel economy is considerably higher. The same effect can be attained using an AC generator set if a battery is added to it, and it is run intermittently. Alternatively, the fuel efficiency of the AC

generator set could be significantly improved if the engine was not so grossly oversized for the small telecom application considered in this evaluation. With all other things being equal, there would be no tangible differences in the fuel consumption of a generator set regardless of whether a DC or an AC generator is being used if they are both loaded in the same manner.

# BATTERY-HYBRID GENERATOR SETS

In the preceding section, it was shown that an engine running continuously at very light loading conditions leads to poor fuel economy. In addition, prolonged operation at low loads is detrimental to engine life, increases maintenance cost and negatively impacts reliability.

To avoid these problems, an engine-driven generator set needs to be properly sized with respect to the expected loads, both peak and continuous. Most manufacturers offer sizing tools to aid in the proper selection of generator sets to match them to the application, optimizing equipment value for the owner. These sizing programs take into account running loads, peak loads, motor starting requirements, tolerance to voltage sags, frequency dips, etc.

In some cases, because of conflicting application requirements, it may be unavoidable to have a large ratio between engine rating and continuous running load. This is typically the case in small telecom sites. For these lower power applications,

a hybrid power generation system incorporating energy storage into a generator set provides an attractive solution for reducing fuel consumption.

Figure 5 shows a schematic representation of a battery-hybrid diesel generator set. Both AC and DC variations are shown in the figure. In either of these configurations, the engine would run intermittently during the battery charging cycle. Hence, the engine load profile would be the same for both cases, and there would be no appreciable differences in fuel consumption between either AC or DC hybrid systems. Also, in spite of battery upkeep, there would be an overall reduction in maintenance cost because of extended engine service intervals for AC and DC hybrid systems – running hours accumulate over a longer calendar period since the engine runs intermittently. In many cases, the operational cost of a hybrid system would be lower than that of a comparable generator set-only system in lower power telecom applications.

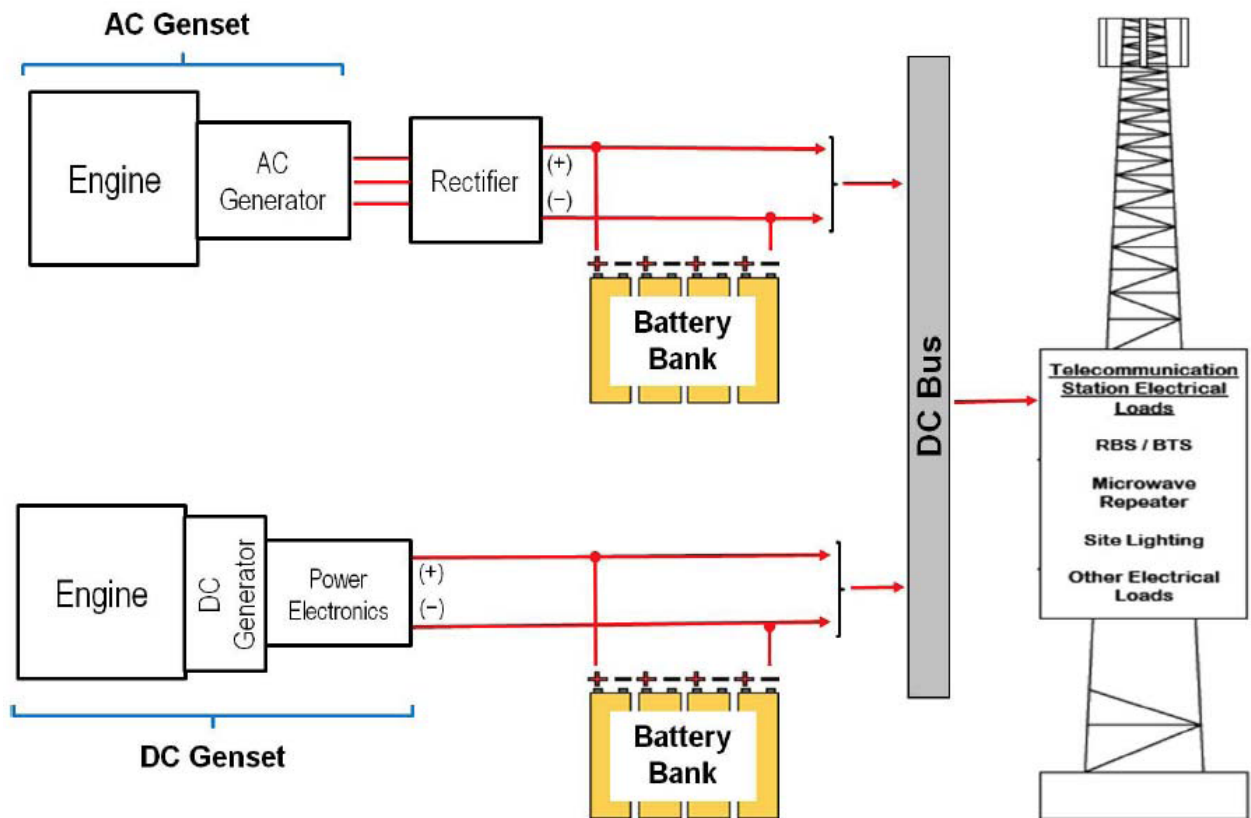

Figure 5: Battery-Hybrid Generator Sets (both AC and DC versions)

Another misconception about DC generators is that they do not require electronics. That may have been the case in the early days of the technology when brushes and mechanical commutators were used in their construction. Modern brushless DC motors and generators now use power electronics in place of brushes and commutators. These electronic devices make it possible to control higher speed generators, tightly regulate voltage, improve power quality and reduce switching losses.

A potential disadvantage of using a DC generator in a telecom application would be the lack of available AC power at the site. Most peripheral equipment at a site runs on AC power, and if only DC power is available, an inverter would be needed to supply the ancillary power for AC equipment.

The decision of whether to select an AC or DC generator should be based primarily on the load profile at the site, mixture of AC and DC loads, desired system complexity and cost. Either choice, when properly made, is likely to yield comparable fuel consumption. It should also be noted that fuel consumption alone, although often of critical importance, may not give a complete picture of the overall operational costs of a power system. Other factors, such as service intervals, scheduled maintenance and the cost of parts and labor, should be taken into account when selecting the type of generator set that best suits the application.

## SUMMARY

There is an ongoing debate in the telecom industry about DC generators providing a fuel economy advantage over AC generators. To validate or reject the hypothesis that DC generators save fuel, Caterpillar engineers conducted fuel consumption tests on four engine-driven DC generator sets, and one AC generator set with a full output rectifier. All units were best examples of what would be currently available in the marketplace for telecom applications.

The data provides solid evidence that under identical loading conditions, there are no significant differences in fuel consumption regardless of whether an AC or a DC generator is used to power the same DC load. In addition, theoretical examination of the overall energy conversion process for both AC and DC engine-driven generator sets proves that the large reductions in fuel consumption claimed by DC generator advocates are false.

It also was shown that the higher fuel consumption reported for some AC systems is caused by operating a diesel engine continuously at extremely light loads where fuel economy is poor. It is not related to generator technology.

The underlying reason DC systems have a perceived fuel economy advantage over AC systems is that they complement the operation of a diesel engine with energy storage via batteries. The batteries enable the power system to run the engine intermittently at higher loads for shorter periods of time during the battery charging cycle. Intermittent loading of the engine near its rated value, instead of loading it lightly continuously, significantly improves average fuel consumption and reduces operational cost. Comparable benefits can be attained using an AC generator set if an energy storage battery is added to the system, along with a rectifier.

In short, with all other things being equal, there will be no tangible differences in the fuel consumption of a generator set regardless of whether a DC or an AC generator is being used if they are both loaded in the same manner.



# ABOUT CATERPILLAR

## About Caterpillar

For more than 90 years, Caterpillar Inc. has been making sustainable progress possible and driving positive change on every continent. Customers turn to Caterpillar to help them develop infrastructure, energy and natural resource assets. With 2016 sales and revenues of \$38.537 billion, Caterpillar is the world's leading manufacturer of construction and mining equipment, diesel and natural gas engines, industrial gas turbines and diesel-electric locomotives. The company principally operates through its three product segments - Construction Industries, Resource Industries and Energy & Transportation - and also provides financing and related services through its Financial Products segment. For more information, visit [caterpillar.com](http://caterpillar.com). To connect with us on social media, visit [caterpillar.com/social-media](http://caterpillar.com/social-media).

For more information, visit [cat.com/powergeneration](http://cat.com/powergeneration).  
To connect, visit [forums.cat.com/powerperspectives](http://forums.cat.com/powerperspectives).

Diesel Solutions Center: [cat.com/powergeneration](http://cat.com/powergeneration)

Online Community: [forums.cat.com/powerperspectives](http://forums.cat.com/powerperspectives)

Facebook: [facebook.com/Caterpillar.Electric.Power](https://facebook.com/Caterpillar.Electric.Power)

YouTube: [youtube.com/CatPowerGeneration](http://youtube.com/CatPowerGeneration)

## BUILT FOR IT.™

LEXE0339-02 July 2017

© 2017 Caterpillar. All Rights Reserved. CAT, CATERPILLAR, BUILT FOR IT, their respective logos, "Caterpillar Yellow," the "Power Edge" trade dress, as well as corporate and product identity used herein, are trademarks of Caterpillar and may not be used without permission.