



Cat[®] Stump Grinders

SKID STEER LOADERS
MULTI TERRAIN LOADERS
COMPACT TRACK LOADERS
COMPACT WHEEL LOADERS

Cat[®] Stump Grinders are designed to economically remove stumps in residential, commercial and agricultural settings. They offer increased production over tow-behind grinders in situations where multiple stump removal is required. The right balance of cutting wheel speed and torque makes quick work of most tree varieties.

Features:

Direct drive system

- The direct drive system features a variable speed, unidirectional, gerotor style motor that delivers optimal cutting wheel speed and high torque for efficient grinding performance.

Heavy-duty cutting wheel and carbide teeth

- A heavy-duty cutting wheel and 32 bolt-on carbide teeth provide maximum durability and cutting efficiency.

Heavy-duty, dual height, pivoting stand feet

- Heavy-duty, dual height, pivoting stand feet provide a stable platform when grinding. Feet are adjustable to compensate for specific machine coupler-to-ground height and tire diameters.

Rounded cutting head

- A rounded cutting head provides better visibility.

Adjustable cutting wheel swing, extension and depth

- Adjustable cutting wheel swing, extension and depth provide superior operator control.

Swing and extension

- Swing and extension are controlled hydraulically from the operator's compartment using an electro-hydraulic valve for greater productivity and swing cycle time efficiency.

Depth control

- Depth is controlled hydraulically on the SG18B and manually on the SG16B.

Extension slider rods

- Extension slider rods chrome plated for long life.

Debris shields

- Debris shields protect the swing cylinders from debris and extend cylinder life.

Anti-cavitation valve

- An anti-cavitation valve improves operator comfort by reducing hydraulic noise levels.

Cat XT[™] and medium pressure hose, couplings and O-ring face seals

- Cat XT and medium pressure hose, couplings and O-ring face seals provide superior, leak-free performance and reliability. All hoses are wrapped with nylon woven cordura sleeving for added operator protection. Hydraulic quick disconnects enable fast tool changes.

Quick coupler

- Rugged, opposing edge design holds the work tool securely and allows the operator to quickly change from one high performance Cat Work Tool to another.

Compatibility

Model Machines

SG16B 226B3, 247B3, 236D, 242D, 246D, 257D, 259D, 262D, 272D, 272D XHP, 277D, 279D, 287D, 289D, 299D, 299D XHP, 906H2, 907H2, 908H2

SG18B* 226B3, 242D, 246D, 257D, 259D, 262D, 272D, 272D XHP, 277D, 279D, 287D, 289D, 299D, 299D XHP

* Requires high flow or high flow XPS option on machine.



Cat Stump Grinders

Specifications

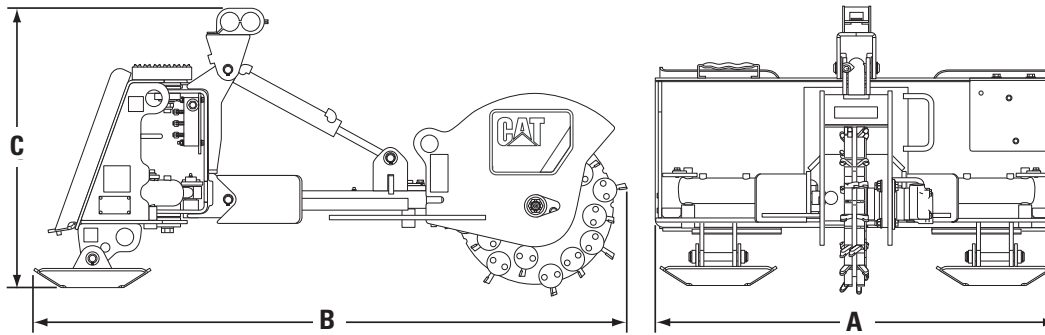

			SG16B		SG18B	
A Overall width	mm (in)		1175	(46)	1175	(46)
B Overall length	mm (in)		1737	(69)	1737	(69)
C Overall height	mm (in)		730	(30)	813	(32)
Unit weight	kg (lb)		379	(775)	400	(840)
Required hydraulic flow	L/min (gpm)		42-86	(11-23)	95-125	(25-33)
Optimal hydraulic pressure	bar (psi)		145-235	(2,100-3,400)	207-310	(3,000-4,500)
Effective displacement	cm ³ (in ³)		80	(4.9)	100	(6.2)
Drive shaft torque @ max pressure			295 N·m (218 lb·ft) @ 230 bar (3,336 psi)		469 N·m (346 lb·ft) @ 290 bar (4,206 psi)	
Cutting head speed (drive shaft) @ max flow			993 rpm @ 80 L/min (21 gpm)		1,230 rpm @ 125 L/min (33 gpm)	
Cutting wheel width (with teeth)	mm (in)		83	(3.3)	83	(3.3)
Cutting wheel diameter (with teeth)	mm (in)		547	(21.5)	547	(21.5)
Cutting width (full swing range)	mm (in)		1524	(60)	1524	(60)
Cutting head swing range			70°		70°	
Cutting height (above ground)	mm (in)		470	(18.5)	470	(18.5)
Cutting height (below ground)	mm (in)		521	(20.5)	521	(20.5)
Cutting head extension	mm (in)		280	(11)	280	(11)
Ground Engaging Tools (G.E.T.)			13 mm (0.5 in) square bolt-on carbide teeth		13 mm (0.5 in) square bolt-on carbide teeth	
Number of carbide teeth per cutting wheel			32		32	

Theoretical values calculated at 100% efficiency.

For more complete information on Cat products, dealer services, and industry solutions, visit us on the web at www.cat.com

© 2013 Caterpillar
All Rights Reserved
Printed in U.S.A.

Materials and specifications are subject to change without notice. Featured machines in photos may include additional equipment. See your Cat dealer for available options.

CAT, CATERPILLAR, SAFETY.CAT.COM, their respective logos, "Caterpillar Yellow" and the "Power Edge" trade dress, as well as corporate and product identity used herein, are trademarks of Caterpillar and may not be used without permission.

AEHQ5835-02 (11-13)
Replaces AEHQ5835-01

