



# Cat<sup>®</sup> Power Box Rakes

SKID STEER LOADERS

MULTI TERRAIN LOADERS

COMPACT TRACK LOADERS

COMPACT WHEEL LOADERS

Cat<sup>®</sup> Power Box Rakes are ideal for clearing and preparing soil in general construction trench restoration, golf course construction and athletic field maintenance. They offer the versatility to de-thatch, remove old lawns and weeds, grade, level, rake, remove debris and prepare seedbeds with one work tool. Their angling ability allows the operator to windrow collected debris for easy pickup and removal. The consistent milling action creates an ideal seedbed for great germination results, laying the groundwork for a perfect lawn. Wet, dry, weedy, hard and rocky soil can be dried, flattened, pulverized and conditioned for seed in one step.

#### Features:

##### Heavy-duty frame, pivot plate and attachment plate

- A heavy-duty frame, pivot plate and attachment plate are featured for reliable operation in rugged terrain and abusive soil conditions.

##### Pure carbide, blunt shaped teeth

- Pure carbide, blunt shaped teeth create a dimpled subsurface to ensure the best possible seedbed sub-base fracture pattern.

##### Two-position winged endplates

- Two-position winged endplates allow close raking to side walks or foundations. They can remain parallel, even during angling, for smoother plowing.

##### Convenient, heavy-duty, deep skid-resistant step

- Convenient, heavy-duty, deep skid-resistant step and a generous cab allow for easy operator entry and exit.

##### Dual independently adjustable gauge wheels

- Dual independently adjustable gauge wheels allow for skim passes for over-seeding or adjust to cut drainage grades.

##### Cat XT<sup>™</sup>-3 ES hose, couplings and O-ring face seals

- Cat XT-3 ES hose, couplings and O-ring face seals provide superior, leak-free performance and reliability. All hoses are wrapped with nylon woven cordura sleeving for added operator protection. Hydraulic quick disconnects enable fast tool changes.

##### Quick coupler

- Rugged, opposing edge design holds the work tool securely and allows the operator to quickly change from one high performance Cat Work Tool to another.

##### Manual or hydraulic angling

- Manual or hydraulic angling up to 20° right or left of center. Hydraulic angling option allows operator to control the power box rake angle from the operator compartment. Manual angling power box rakes can be easily converted to hydraulic angling.

## Compatibility

#### Model Machines

**PR172** 226B3, 247B3, 236D, 242D, 246D, 257D, 259D, 262D, 272D, 272D XHP, 277D, 279D, 287D, 289D, 299D, 299D XHP, 908H2

**PR184** 226B3, 247B3, 236D, 242D, 246D, 257D, 259D, 262D, 272D, 272D XHP, 277D, 279D, 287D, 289D, 299D, 299D XHP, 908H2

**PR190** 226B3, 247B3, 236D, 242D, 246D, 257D, 259D, 262D, 272D, 272D XHP, 277D, 279D, 287D, 289D, 299D, 299D XHP, 908H2

# Cat Power Box Rakes

## Specifications

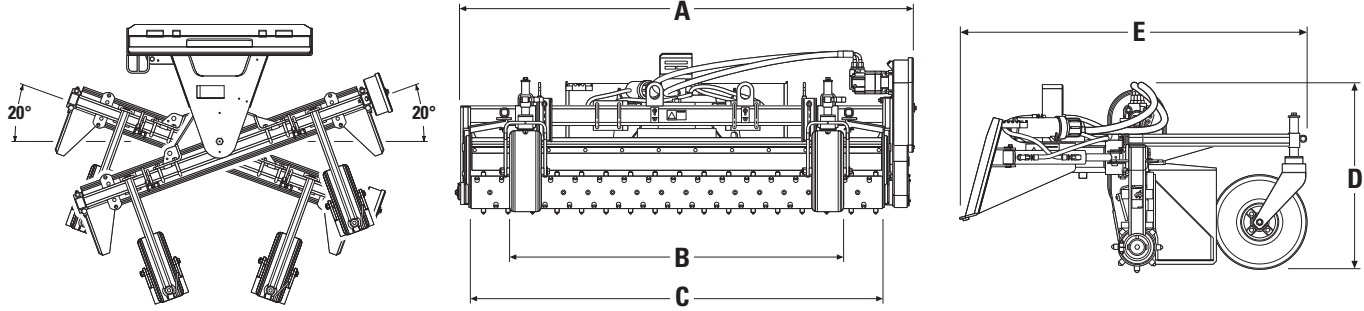

			<b>PR172</b>		<b>PR184</b>		<b>PR190</b>	
<b>A</b> Overall width	mm	(in)	2057	(81)	2362	(93)	2515	(99)
<b>B</b> Width across tires, nominal	mm	(in)	1386	(55)	1732	(68)	1845	(73)
<b>C</b> Roller width	mm	(in)	1829	(72)	2134	(84)	2286	(90)
<b>D</b> Overall height	mm	(in)	847	(34)	847	(34)	953	(37.5)
<b>E</b> Overall length	mm	(in)	1626	(64)	1626	(64)	1626	(64)
Raking width at max angle (20°)	mm	(in)	1727	(68)	2007	(79)	2159	(85)
Unit weight (manual)	kg	(lb)	408	(900)	465	(1,026)	588	(1,296)
Unit weight (hydraulic)	kg	(lb)	420	(925)	476	(1,050)	599	(1,320)
Maximum angle			20°		20°		20°	
Hydraulic flow range	L/min	(gpm)	49-86	(13-23)	57-86	(15-23)	57-86	(15-23)
Hydraulic pressure	bar	(psi)	230	(3,340)	230	(3,340)	230	(3,340)

For more complete information on Cat products, dealer services, and industry solutions, visit us on the web at [www.cat.com](http://www.cat.com)

© 2013 Caterpillar Inc.  
All Rights Reserved  
Printed in U.S.A.

Materials and specifications are subject to change without notice. Featured machines in photos may include additional equipment. See your Cat dealer for available options.

CAT, CATERPILLAR, SAFETY.CAT.COM, their respective logos, "Caterpillar Yellow" and the "Power Edge" trade dress, as well as corporate and product identity used herein, are trademarks of Caterpillar and may not be used without permission.

AEHQ5834-02 (08-13)  
Replaces AEHQ5834-01

