



C9 ACERT™ Industrial Engine

Tier 3/Stage IIIA
280 bkW/375 bhp @ 2200 rpm



Image shown may not reflect actual engine

CAT® ENGINE SPECIFICATIONS

I-6, 4-Stroke-Cycle Diesel

Bore.....	112.0 mm (4.41 in)
Stroke.....	149.0 mm (5.87 in)
Displacement.....	8.8 L (537.01 in ³)
Aspiration.....	Turbocharged Aftercooled
Compression Ratio.....	16.1:1
Rotation (from flywheel end).....	Counterclockwise
Cooling System.....	13.9 liters, 3.7 gallons
Lube Oil System (refill).....	32.0 liters, 8.5 gallons
Weight, Net Dry (approximate kg, lb).....	776 kg, 1711 lb

FEATURES

Emissions

Meets U.S. EPA Tier 3, EU Stage IIIA emission requirements.

Worldwide Supplier Capability

Caterpillar

- Casts engine blocks, heads, and cylinder liners
- Machines critical components
- Assembles complete engine
- Factory-designed systems built at Caterpillar ISO 9001:2000 certified facilities
- Ownership of these manufacturing processes enables Caterpillar to produce high quality, dependable product.

Testing

Prototype testing on every model:

- proves computer design
- verifies system torsional stability
- functionality tests every model

Every Caterpillar engine is dynamometer tested under full load to ensure proper engine performance.

Full Range of Attachments

Wide range of bolt-on system expansion attachments, factory designed and tested.

Unmatched Product Support Offered Through Worldwide Caterpillar Dealer Network

More than 1,500 dealer outlets

Caterpillar factory-trained dealer technicians service every aspect of your industrial engine

99.7% of parts orders filled within 24 hours worldwide

Caterpillar parts and labor warranty

Preventive maintenance agreements available for repair before failure options

Scheduled Oil Sampling program matches your oil sample against Caterpillar set standards to determine:

- internal engine component condition
- presence of unwanted fluids
- presence of combustion by-products

Web Site

For all your industrial power requirements, visit www.cat-industrial.com.



C9 ACERT™ Industrial Engine

Tier 3/Stage IIIA

280 bkW/375 bhp @ 2200 rpm

STANDARD ENGINE EQUIPMENT

Air Inlet System

Air to air aftercooled (ATAAC)
Turbocharged

Control System

Electronic governing, PTO speed control
Programmable ratings
Cold mode start strategy
Automatic altitude compensation
Power compensation for fuel temperature
Programmable low and high idle and total engine limit
Electronic diagnostics and fault logging
Engine monitoring system
J1939 Broadcast (diagnostic and engine status)
ADEM™ A4

Cooling System

Thermostats and housing, vertical outlet
Jacket water pump, centrifugal
Water pump, inlet

Exhaust System

Exhaust manifold, dry
Optional exhaust outlet

Flywheels and Flywheel Housing

SAE No. 1 Flywheel housing

Fuel System

HEUI injection
Fuel filter, secondary (2 micron high performance)
Fuel transfer pump
Fuel priming pump
ACERT™ Technology

Lube System

Crankcase breather
Oil cooler
Oil filler
Oil filter
Oil pan front sump
Oil dipstick
Oil pump (gear driven)

General

Paint, Caterpillar Yellow
Vibration damper
Lifting eyes



**C9 ACERT™
Industrial Engine**

Tier 3/Stage IIIA

280 bkW/375 bhp @ 2200 rpm

PERFORMANCE CURVES

IND - D - DM8120-00

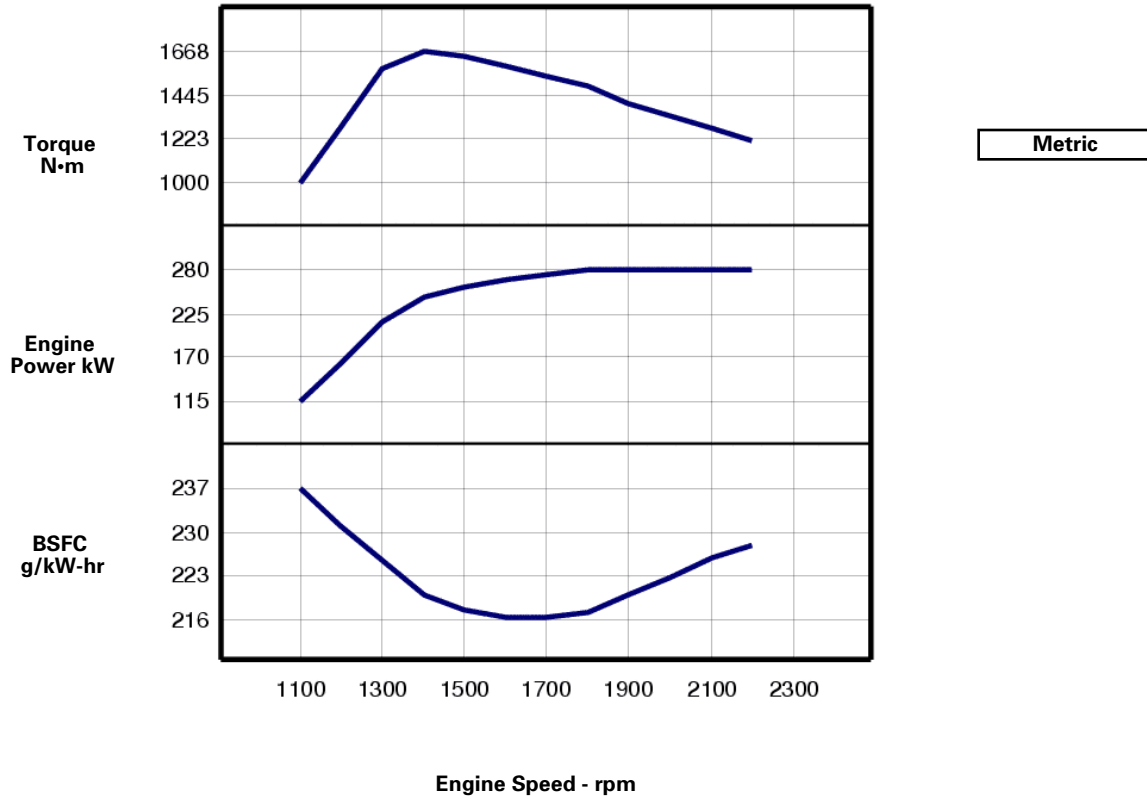

Engine Speed rpm	Engine Power kW	Torque N·m	BSFC g/kW-hr	Fuel Rate L/hr
2200	280	1215	228	76.1
2100	280	1273	225.9	75.4
2000	280	1337	222.8	74.4
1900	280	1407	219.7	73.3
1800	280	1485	217.1	72.5
1700	274	1537	216.3	70.6
1600	266	1589	216.5	68.7
1500	257	1638	217.3	66.6
1400	245	1668	219.8	64.0
1300	215	1580	225.3	57.8
1200	160	1270	231.2	44.0
1100	115	1000	236.8	32.5



**C9 ACERT™
Industrial Engine**

Tier 3/Stage IIIA

280 kW/375 bhp @ 2200 rpm

PERFORMANCE CURVES

IND - D - DM8120-00

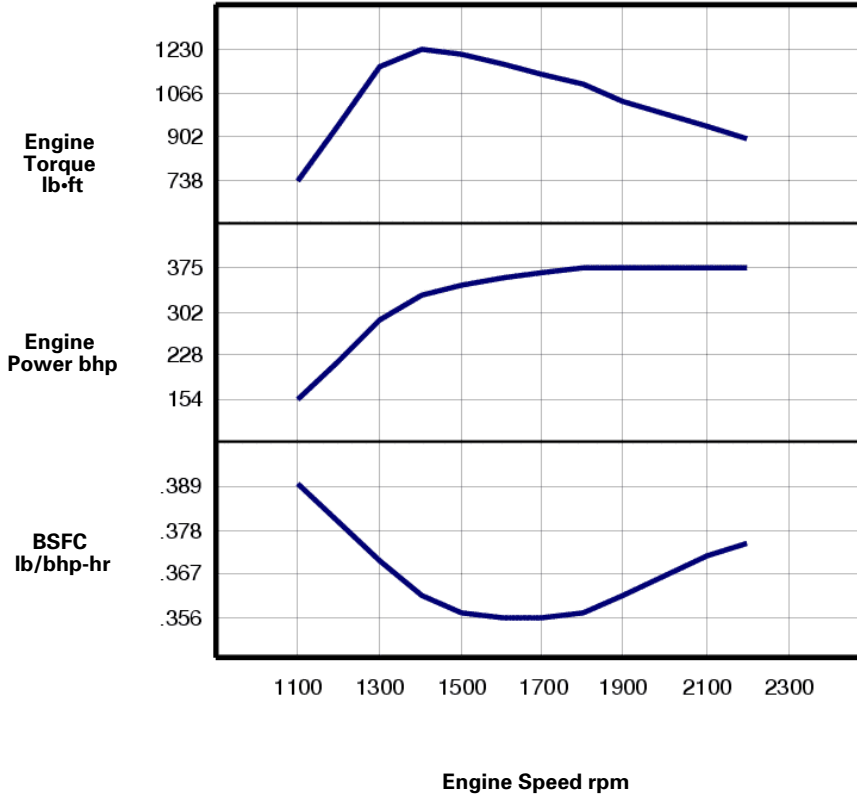

English

Engine Speed rpm	Engine Power bhp	Engine Torque lb-ft	BSFC lb/bhp-hr	Fuel Rate gal/hr
2200	375	896	.375	20.1
2100	375	939	.371	19.9
2000	375	986	.366	19.7
1900	375	1038	.361	19.4
1800	375	1095	.357	19.2
1700	367	1134	.356	18.7
1600	357	1172	.356	18.1
1500	345	1208	.357	17.6
1400	328	1230	.361	16.9
1300	288	1165	.370	15.3
1200	214	937	.380	11.6
1100	154	738	.389	8.6



C9 ACERT™ Industrial Engine

Tier 3/Stage IIIA

280 bkW/375 bhp @ 2200 rpm

RATINGS AND CONDITIONS

IND - D For service where maximum power is required for periodic overloads.

Engine Performance Diesel Engines — 7 liter and higher All rating conditions are based on SAE J1995, inlet air standard conditions of 99 kPa (29.31 in. Hg) dry barometer and 25°C (77°F) temperature. Performance measured using a standard fuel with fuel gravity of 35° API having a lower heating value of 42,780 kJ/kg (18,390 btu/lb) when used at 29° C (84.2° F) with a density of 838.9 g/L.

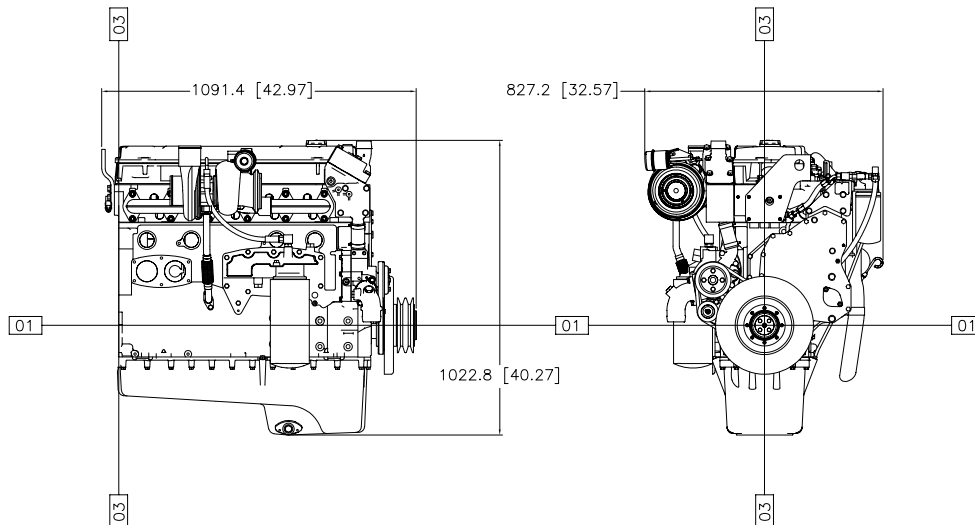

Engine Dimensions

(1) Length	1091.4 mm (42.97 in)
(2) Width	827.2 mm (32.57 in)
(3) Height	1022.8 mm (40.27 in)

Note: Do not use for installation design. See general dimension drawings for detail (Drawing # 2651026).

Performance Number: DM8120-00

Feature Code: C09D114 Arr. Number: 2524433

Materials and specifications are subject to change without notice.

16289399

© 2012 Caterpillar

All rights reserved.

The International System of Units (SI) is used in this publication.

CAT, CATERPILLAR, their respective logos, "Caterpillar Yellow," the "Power Edge" trade dress, as well as corporate and product identity used herein, are trademarks of Caterpillar and may not be used without permission.