



# Cat<sup>®</sup> Special Application Brooms

WHEEL LOADERS  
BACKHOE LOADERS

## FEATURES:

### Built for Heavy-Duty Sweeping Situations

- Special Application Angle Brooms sweep debris in rugged duty applications such as sewer and pipeline, governmental and coal seam applications. These brooms are specifically made for sweeping heavy material and coal seams.
- Built for use on Wheel Loaders, Integrated Tool Carriers and Backhoe Loaders.

### Durable, Reliable Design

- Frame of the Special Application Broom is built to handle the torsion and flexing encountered in heavy-duty applications.
- Water lines, jets, pumps and motors are located behind a 14-gauge steel shield for protection against damage from debris. These components are well protected, yet easily accessible.
- Caterpillar XT<sup>™</sup>-3 ES hoses, couplings and o-ring face seals provide superior leak free performance and reliability. All hoses are wrapped with nylon woven Codura sleeving for added operator protection.
- Broom bearings are maintenance-free for long life.

### Quick Change Angling

- Cat Special Application Brooms angle hydraulically—30° to either side—or can operate in a straight position. Using a windrowing action, Special Application Brooms move loose debris ahead and to the side of the surface being swept.
- Operator controls broom angle from the cab.

### Easy to Use

- To save wear on bristles, broom has two indicators – level and pitch – to aid operator in positioning for proper operation.
- Down pressure adjustment is easily accessible and requires only one wrench to tighten or loosen.

### Heavy-Duty Brush Elements

- High strength, extra-thick poly bristles provide the aggressive sweeping required, while keeping weight to a minimum and structural integrity to a maximum.
- Special Application Broom bristles are 4.33mm (0.17 inch) — 32% larger than standard brush bristles—for strength and durability.
- This heavy-duty broom features a reinforced core for additional strength where bristles are mounted to the broom.
- When required, brush elements are quickly and easily replaced.

### Options

- An optional extension is available for the metal shield.
- An optional water sprinkler kit is available for dust suppression.

## Special Application Broom/Wheel Loader and Backhoe Loader Compatibility

Recommended machine matches. Contact your local Cat Dealer for more detailed matching information.

Model	Machines
2.5m	924, 928, 930, IT14, IT28, 416, 420, 430, 446, 450
3.0m	938, 950, 962, IT38, IT62

# Cat Special Application Brooms

## Specifications

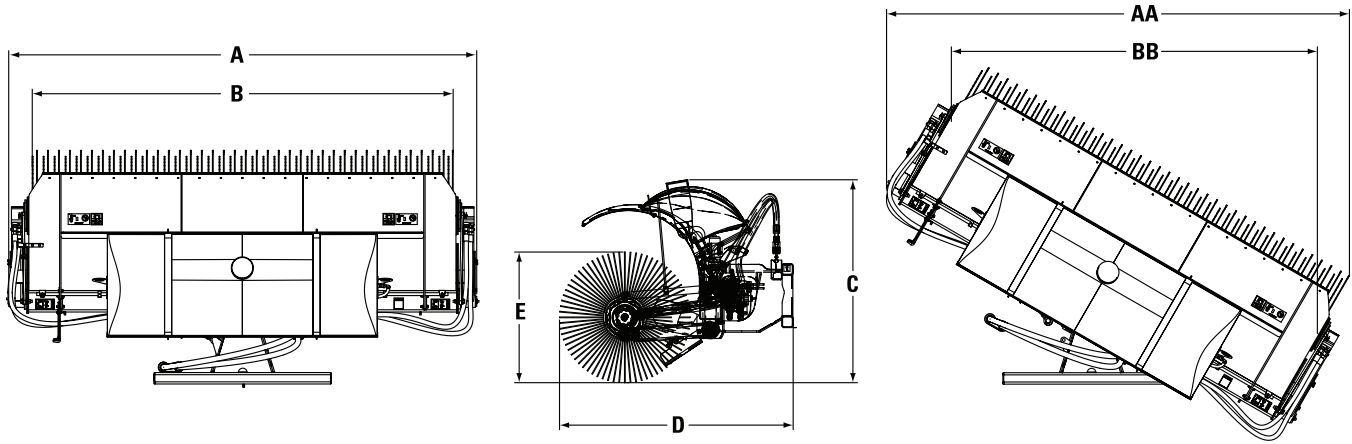

			2.5m		3.0m	
Weight (Hydraulic Angle)	kg	(lb)	743	(1640)	816	(1800)
<b>A</b> Overall Width, straight	mm	(in)	2757	(108.5)	3257	(128)
<b>B</b> Sweeping Width, straight	mm	(in)	2500	(98.4)	3000	(118)
<b>AA</b> Overall Width, angled $\pm 30^\circ$	mm	(in)	2742	(108)	3242	(128)
<b>BB</b> Sweeping Width, angled $\pm 30^\circ$	mm	(in)	2165	(85.2)	2600	(102)
<b>C</b> Height	mm	(in)	1421.5	(56)	1421.5	(56)
<b>D</b> Length	mm	(in)	1636	(64.4)	1636	(64.4)
<b>E</b> Brush Diameter	mm	(in)	915	(36)	915	(36)
Water Capacity (optional)	L	(gal)	240	(63)	240	(63)
Optimal Working Speed	kph	(mph)	4–19	(2.5–12)	4–19	(2.5–12)

For more complete information on Cat products, dealer services, and industry solutions, visit us on the web at [www.cat.com](http://www.cat.com)

GEHQ0182-02 (07-11)

©2011 Caterpillar  
All Rights Reserved  
Printed in U.S.A.

Replaces GEHQ0182-01

Materials and specifications are subject to change without notice. Featured machines in photos may include additional equipment. See your Cat dealer for available options.

CAT, CATERPILLAR, their respective logos, "Caterpillar Yellow," and the POWER EDGE trade dress, as well as corporate and product identity used herein, are trademarks of Caterpillar and may not be used without permission.

