

924K, 930K, 938K

Wheel Loaders



	924K	930K	938K
Engine Model*	Cat® C7.1 ACERT™	Cat C7.1 ACERT	Cat C7.1 ACERT
Maximum Gross Power:			
ISO 14396 (DIN)	105 kW (143 hp)	119 kW (162 hp)	140 kW (190 hp)
ISO 14396	105 kW (141 hp)	119 kW (160 hp)	140 kW (188 hp)
Bucket Capacity	1.7-5.0 m ³ (2.2-6.5 yd ³)	2.1-5.0 m ³ (2.7-6.5 yd ³)	2.5-5.0 m ³ (3.3-6.5 yd ³)
Full Turn Tip Load	7488 kg (16,508 lb)	8477 kg (18,689 lb)	9698 kg (21,380 lb)
Operating Weight	11 550 kg (25,464 lb)	13 135 kg (28,958 lb)	15 146 kg (33,301 lb)

*Engine meets U.S. EPA Tier 3/EU Stage IIIA emission standards.

Experience the Difference.

Optimized Parallel Lift Z-bar Linkage

Combines the digging efficiency of a traditional Z-bar with tool carrier capabilities for superior performance and flexibility.

Cab and Controls

Large, spacious cab features excellent visibility to the front and rear, extremely low sound levels and low-effort ergonomic joystick controls so you can concentrate on your work. In cab adjustments are easy with intuitive controls and an easy to read optional display.

Intelligent Power Management

A smooth, step-less electronically controlled hydrostatic transmission provides adjustable power to the ground and superb groundspeed control for fast digging cycles and the flexibility to efficiently perform a multitude of tasks.

Powerful Predictable Hydraulics

The system senses demand and adjusts flow and pressure to match. Working with buckets, forks and other work tools has never been more efficient.

Work Tools

A new line of optimized Performance Series buckets, pallet and construction forks as well as a wide range of work tools are available in a Pin-on, Fusion™ coupler or ISO 23727 coupler interface.

Serviceability

Daily service points are easily accessible from ground level. Extended service intervals and excellent service access make daily checks quick and easy, allowing you to get to work sooner.

Contents

Parallel Lift Loader Linkage.....	4
Industry Leading Operator Station.....	5
Power Train.....	6
Hydraulics	7
Work Tools.....	8
Options.....	9
Serviceability and Customer Support.....	10
Wheel Loader Specifications	11
Bucket Specifications	18
Sand and Gravel Bucket Specifications	27
Operating Specifications	28
Supplemental Specifications	32
Standard Equipment.....	33
Optional Equipment.....	34





The Cat 924K, 930K and 938K Wheel Loaders set a new standard for productivity, fuel efficiency and comfort. Extremely low sound levels, large spacious cab and intuitive controls keep you working comfortably all day long. The new optimized Z-bar loader linkage delivers the performance and breakout forces of a traditional Z-bar linkage with the parallelism and load handling capability of a tool carrier. Experience the new industry benchmark.

Parallel Lift Loader Linkage

Optimized Z-bar linkage delivers enhanced visibility with maximum productivity.



Optimized Z-bar Linkage

The new optimized patent-pending Z-bar linkage combines the digging efficiency of a traditional Z-bar with tool carrier capabilities for great performance and versatility.

- Parallel lift and high tilt forces throughout the working range help you safely and confidently handle loads with precise control.
- Linkage features excellent visibility to the bucket cutting edge and fork tips.
- High Lift versions are also available on the 930K and 938K.



Industry Leading Operator Station

Superior visibility, ergonomics and comfort.



Best Seat on the Job Site

Enjoy all day comfort in the spacious new K Series cab:

- Extremely low sound levels.
- Superior visibility to the work tool due to wide curved windshield, redesigned Z-bar linkage, lines routing and work tool design.
- Automatic temperature control.
- Seat-mounted, ergonomic joystick for lift and tilt functions. Joystick includes integrated Forward/Neutral/Reverse switch and optional differential lock trigger, third and fourth function auxiliary hydraulics.
- Easy access to the cab with ergonomically placed grab rails, walk-up steps and large platform.

Easy to Use Instrument Panel and Display

An optional secondary display provides easy access to vital machine parameters and works in conjunction with the standard soft touch panel to allow real time adjustments.

- Machine information and diagnostics at a glance.
- Real time and historic fuel usage.
- Backup camera display.
- Help button plus 22 language capability.
- Adjustment of functions such as creep, third function flow, throttle and rimpull.



Power Train

Maximum machine power, reduced fuel consumption.



Intelligent Power Management

The Caterpillar exclusive Intelligent Power Management system actively monitors operator input and power availability to keep the machine working at peak efficiency.

Engine

The Cat C7.1 ACERT engine provides cleaner, quieter operation while delivering superior performance and durability. The engine meets U.S. EPA Tier 3 and EU Stage IIIA emission requirements. Maximum engine speed is now 1,800 rpm for reduced fuel consumption and lower sound levels. The engine also features:

- Class-leading fuel efficiency, significantly reducing owning and operating costs.
- Configurable auto idle shut down feature as standard equipment.

Transmission

A smooth, step-less electronically controlled hydrostatic transmission provides adjustable power to the ground and superb groundspeed control for a multitude of tasks.

- Four speed ranges ensure maximum controllability for any task.
- Rimpull control enables you to match available tractive power to underfoot conditions, helping reduce tire wear.
- Creeper control lets you adjust machine groundspeed when using work tools such as brooms, snow blowers and brushcutters.
- Throttle lock feature allows you to maintain constant engine RPM regardless of machine speed.

Axles and Brakes

Fully locking front differential axles are optional and can be engaged at full torque on the go with a button on the joystick. Limited slip differentials are also optional on the rear. Brake system includes independent service brakes on front and rear axles and a spring applied, electronically activated park brake.

Hydraulics

Smooth, efficient operation helps you get the job done faster.

Load-Sensing Hydraulic System

K Series machines feature a new electro-hydraulic control system that is governed by the Intelligent Power Management system. The load-sensing, variable flow system senses work demand and adjusts flow and pressure to match. This allows full hydraulic forces at any engine speed.

- Programmable in-cab kick-outs are easy to set on the go for tilt, lower and lift. This feature is ideal for applications where the work cycle is repeatable.
- Caterpillar exclusive electro-hydraulic snubbing at programmed kickouts and rack/dump stops greatly improves operator comfort and component life in addition to improved material retention.
- Adjustable third function flow through the secondary display (when equipped) for use with hydro-mechanical work tools.
- Optional Ride Control System provides an even smoother ride and excellent material retention.
- Designed with dedicated pumps for steering and implements so there is no compromise in cycle times and efficiency for multi-function operation.



Work Tools

Do more jobs with one machine.



The Right Tool for the Job

An extensive range of work tools and bucket styles are available to make your Cat Wheel Loader one of the most versatile machines on the job site.

Performance Series Buckets

Performance Series Buckets utilize a system-based approach to balance bucket shape with the machine's linkage, weight, lift and tilt capacities. They deliver higher fill factors and better material retention for significant productivity and fuel efficiency improvements. The buckets feature a longer floor, open throat and curved side bars.

Additional Buckets

- Light Material
- Multi Purpose
- Sand and Gravel
- High Dump
- Wood Chip

Material Handling Work Tools

- Pallet Forks
- Construction Forks
- Material Handling Arm

Work Tools for Special Applications

- Dozer Blades
- Snow Plows
- Brooms
- Rakes
- Log and Lumber Forks
- Pipe and Pole Forks
- Side Dump Buckets
- Grapple Buckets
- Grading Buckets

Couplers

The Cat Fusion interface provides coupler flexibility without compromise in breakout force and dump clearance. The advanced wedging mechanism creates a tight, rattle-free fit, eliminating play and wear for long service life. The open coupler frame design provides excellent line of sight to the work tool. An ISO 23727 coupler interface is also available for use with competitive work tools.

Options

Customize your machine to meet your needs.

Configure the Machine the Way You Want It

A variety of options are available on the Cat K Series™ Wheel Loaders to suit your specific application needs. See your Cat dealer for more information about the features below and additional options.



Coupler Options



*High Lift Linkage
(930K and 938K)*



Counterweight Options



HID Lights



Turbine Precleaner



Rear Camera in Grill



Front Light Guards



Rear Light Guards



Windshield Guard



Flexport™ Tires



*3rd and 4th Function
Hydraulics*



Cold Start Package



Semi-Cab



Product Link™



Side Power Train Guard

Additional options include:

- Differential Lock
- Secondary Steering
- Steer Cylinder Guards
- Hitch Guards
- Tilt Cylinder Guards
- Remote Axle Breathers
- Power Train Side Guards
- Driveshaft Guard
- Rear Waste Gate
- RESPA Cab Filtration
- Lower Power Train Guard
- Crankcase Guard
- Full Coverage Fenders
- Optional Toolbox
- Autolube (930K and 938K)

Serviceability

Easy service to keep your machine working.



All service points are accessible from ground level. Three large service doors can be opened and closed in any order to give full access to filters and service points. Extended service intervals reduce service time and maximize uptime. Additional service features include:

- Caterpillar exclusive electric fuel priming pump.
- Jump start studs as standard equipment.
- Single plane cooling system with 6 fins per inch coolers as standard.
- Swing-up air conditioner condenser for easy clean out.
- Product Link™ ready (standard).

Customer Support

Unmatched support makes the difference.

Renowned Cat Dealer Support

Your Cat dealer is ready to help you every step of the way. From new or used machine sales, to rental or rebuild options, your Cat dealer can provide an optimal solution to your business needs. Unsurpassed worldwide parts availability, trained technicians and customer support agreements maximize your machine uptime.



924K, 930K, 938K Wheel Loader Specifications

Engine

	924K		930K		938K	
Engine Model	Cat C7.1 ACERT		Cat C7.1 ACERT		Cat C7.1 ACERT	
Maximum Gross Power						
ISO 14396 (DIN)	105 kW	143 hp	119 kW	162 hp	140 kW	190 hp
ISO 14396	105 kW	141 hp	119 kW	160 hp	140 kW	188 hp
Rated Net Power @ 1,800 rpm						
SAE J1349	101 kW	135 hp	115 kW	154 hp	136 kW	182 hp
ISO 9249 (1977)/EEC 80/1269	102 kW	137 hp	116 kW	156 hp	137 kW	184 hp
ISO 9249 (DIN)	102 kW	139 hp	116 kW	158 hp	137 kW	186 hp
Maximum Gross Torque						
ISO 14396	725 N·m	535 lbf-ft	787 N·m	580 lbf-ft	912 N·m	673 lbf-ft
Maximum Net Torque						
SAE J1349	700 N·m	516 lbf-ft	750 N·m	553 lbf-ft	874 N·m	645 lbf-ft
ISO 9249 (1977)/EEC 80/1269	708 N·m	522 lbf-ft	758 N·m	559 lbf-ft	883 N·m	651 lbf-ft
Displacement	7.0 L	428 in ³	7.0 L	428 in ³	7.0 L	428 in ³
Bore	105 mm	4 in	105 mm	4 in	105 mm	4 in
Stroke	135 mm	5 in	135 mm	5 in	135 mm	5 in

- Net power ratings are tested at the reference conditions for the specified standard.
- Net power shown is the power available at the flywheel when the engine is equipped with alternator, air cleaner, diesel exhaust filter, and fan at minimum speed.
- No derating required up to 3000 m (10,000 ft) altitude. Auto derate protects hydraulic and transmission systems.
- Flywheel per the SAE reference conditions when the fan is at maximum speed.
- Cat C7.1 engine meets U.S. EPA Tier 3 (EU Stage IIIA) emission requirements.

Engine Power and Torque

924K

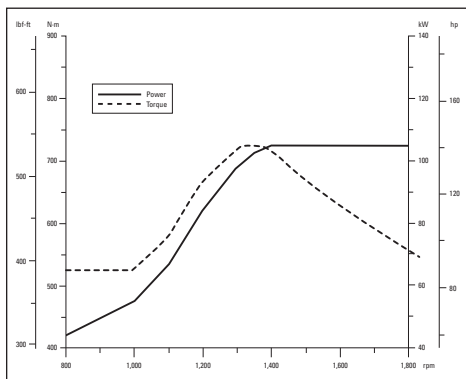

930K

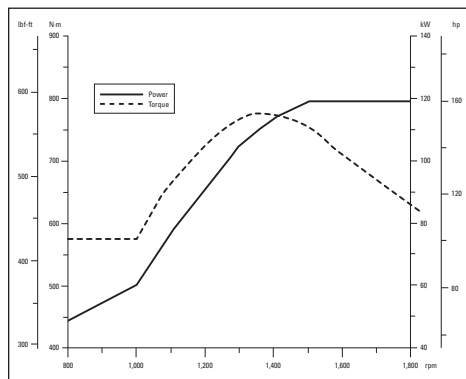

938K

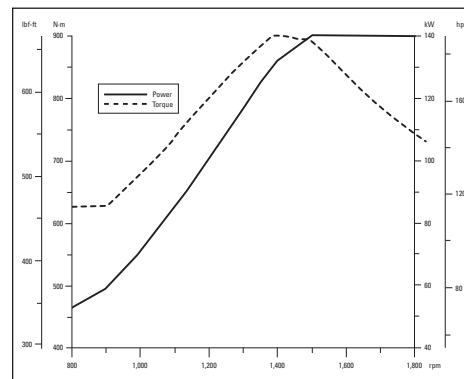

924K, 930K, 938K Wheel Loader Specifications

Buckets

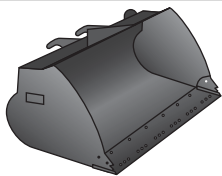

- Performance Series Buckets utilize a long floor and open throat resulting in easy loading and good material retention.

	924K		930K		938K	
General Purpose	1.7-2.5 m ³	2.2-3.3 yd ³	2.1-2.7 m ³	2.7-3.5 yd ³	2.5-3.2 m ³	3.3-4.2 yd ³
Light Material	3.5-5.0 m ³	4.6-6.5 yd ³	3.5-5.0 m ³	4.6-6.5 yd ³	3.5-5.0 m ³	4.6-6.5 yd ³

Weights

	924K		930K		938K	
Operating weight – Standard Lift	11 550 kg	25,464 lb	13 135 kg	28,958 lb	15 146 kg	33,391 lb
Operating weight – High Lift	N/A	N/A	13 382 kg	29,502 lb	15 395 kg	33,940 lb

- Specifications shown are for a machine configured with general purpose pin on bucket, bolt-on cutting edges, optional counterweights, 80 kg (176 lb) operator, and Michelin 20.5 R25 (L-3) XHA2 tires.
 - 924K is configured with a 1.9 m³ (2.5 yd³) pin on bucket with bolt-on cutting edge.
 - 930K is configured with a 2.1 m³ (2.7 yd³) pin on bucket with bolt-on cutting edge.
 - 938K is configured with a 2.5 m³ (3.3 yd³) pin on bucket with bolt-on cutting edge.

Steering



- Steering system uses a dedicated load sensing variable displacement pump with dual double acting cylinders.

	924K		930K		938K	
Steering articulation angle each direction	40°		40°		40°	
Steering cylinder: double acting						
Bore diameter	70 mm	2.8 in	70 mm	2.8 in	80 mm	3.1 in
Rod diameter	40 mm	1.6 in	40 mm	1.6 in	50 mm	2 in
Stroke	438 mm	17.2 in	438 mm	17.2 in	399 mm	15.7 in
Maximum flow – steering pump	125 L/min	33 gal/min	130 L/min	34 gal/min	130 L/min	34 gal/min
Maximum working pressure – steering pump	24 130 kPa	3,500 psi	24 130 kPa	3,500 psi	24 130 kPa	3,500 psi
Maximum steering torque						
0° (straight machine)	50 375 N·m	37,155 lbf-ft	50 375 N·m	37,155 lbf-ft	57 630 N·m	42,506 lbf-ft
40° (full turn)	37 620 N·m	27,747 lbf-ft	37 620 N·m	27,747 lbf-ft	42 570 N·m	31,398 lbf-ft
Steering cycle times (full left to full right)						
800 rpm: pump flow limited	2.8 seconds		2.8 seconds		3.1 seconds	
1,800 rpm: 90 rpm steering wheel speed	2.4 seconds		2.4 seconds		2.3 seconds	
Number of steering wheel turns						
Full left to full right or full right to full left	3.5 turns		3.5 turns		3.3 turns	

Loader Hydraulic System



- Implement system uses a dedicated load sensing variable displacement pump with dual double acting lift cylinders and a single double acting tilt cylinder.
- 3rd function flow is fully adjustable from 20% to 100% of maximum flow through the secondary display when equipped.
- 4th function flow is fixed.

	924K		930K		938K	
Maximum flow – implement pump	150 L/min	40 gal/min	190 L/min	50 gal/min	190 L/min	50 gal/min
3rd function maximum flow	150 L/min	40 gal/min	190 L/min	50 gal/min	190 L/min	50 gal/min
4th function maximum flow	75 L/min	20 gal/min	75 L/min	20 gal/min	75 L/min	20 gal/min
Maximum working pressure – implement pump	26 000 kPa	3,771 psi	25 000 kPa	3,626 psi	28 000 kPa	4,061 psi
Relief pressure – tilt cylinder	28 000 kPa	4,061 psi	28 000 kPa	4,061 psi	30 000 kPa	4,351 psi
3rd function maximum working pressure	26 000 kPa	3,771 psi	25 000 kPa	3,626 psi	28 000 kPa	4,061 psi
3rd function relief pressure	28 000 kPa	4,061 psi	28 000 kPa	4,061 psi	30 000 kPa	4,351 psi
4th function maximum working pressure	26 000 kPa	3,771 psi	25 000 kPa	3,626 psi	28 000 kPa	4,061 psi
4th function relief pressure	28 000 kPa	4,061 psi	28 000 kPa	4,061 psi	30 000 kPa	4,351 psi
Lift cylinder: double acting						
Bore diameter	110 mm	4.3 in	120 mm	4.7 in	120 mm	4.7 in
Rod diameter	60 mm	2.4 in	65 mm	2.6 in	65 mm	2.6 in
Stroke	728 mm	28.7 in	728 mm	28.7 in	789 mm	31.1 in
Tilt cylinder: double acting						
Bore diameter	130 mm	5.1 in	150 mm	5.9 in	150 mm	5.9 in
Rod diameter	70 mm	2.8 in	90 mm	3.5 in	90 mm	3.5 in
Stroke	516 mm	20.3 in	555 mm	21.9 in	555 mm	21.9 in
Hydraulic cycle times (1,800 rpm)						
Raise (ground level to maximum lift)	5.4 seconds		5.1 seconds		5.5 seconds	
Dump (at maximum lift height)	1.5 seconds		1.5 seconds		1.5 seconds	
Float down (maximum lift to ground level)	2.6 seconds		2.7 seconds		2.7 seconds	
Total cycle time	9.5 seconds		9.3 seconds		9.7 seconds	

Service Refill Capacities

	924K		930K		938K	
Fuel tank	195 L	51.5 gal	195 L	51.5 gal	195 L	51.5 gal
Cooling system	32 L	8.5 gal	32 L	8.5 gal	32 L	8.5 gal
Engine crankcase	19.5 L	5.2 gal	19.5 L	5.2 gal	19.5 L	5.2 gal
Transmission (gear box)	8.5 L	2.2 gal	8.5 L	2.2 gal	11 L	2.9 gal
Axles						
Front	21 L	5.5 gal	26 L	6.9 gal	35 L	9.2 gal
Rear	21 L	5.5 gal	25 L	6.6 gal	35 L	9.2 gal
Hydraulic system (including tank)	160 L	42.3 gal	165 L	43.6 gal	170 L	44.9 gal
Hydraulic tank	90 L	23.8 gal	90 L	23.8 gal	90 L	23.8 gal

924K, 930K, 938K Wheel Loader Specifications

Transmission



*Creeper control allows maximum speed range adjustability from 1 km/h (0.6 mph) to 13 km/h (8 mph) in Range 1 through the secondary display when equipped. Factory default is 7 km/h (4.4 mph).

	924K		930K		938K	
Forward						
Range 1*	1-13 km/h	0.6-8.0 mph	1-13 km/h	0.6-8.0 mph	1-13 km/h	0.6-8.0 mph
Range 2	13 km/h	8 mph	13 km/h	8 mph	13 km/h	8 mph
Range 3	27 km/h	17 mph	27 km/h	17 mph	27 km/h	17 mph
Range 4	40 km/h	25 mph	40 km/h	25 mph	40 km/h	25 mph
Reverse						
Range 1*	1-13 km/h	0.6-8.0 mph	1-13 km/h	0.6-8.0 mph	1-13 km/h	0.6-8.0 mph
Range 2	13 km/h	8 mph	13 km/h	8 mph	13 km/h	8 mph
Range 3	27 km/h	17 mph	27 km/h	17 mph	27 km/h	17 mph
Range 4	40 km/h	25 mph	40 km/h	25 mph	40 km/h	25 mph

Power Train

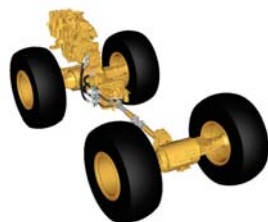

• Power train is governed by the Caterpillar exclusive Intelligent Power Management system to deliver peak performance and efficiency.

**Optional differential front locking axle can be engaged on the go at full torque up to 10 km/h (6.2 mph) on the 924K/930K and up to 20 km/h (12.4 mph) on the 938K.

	924K	930K	938K
Front axle	Fixed	Fixed	Fixed
Traction aid**	Open differential (standard) Locking differential (optional)	Open differential (standard) Locking differential (optional)	Open differential (standard) Locking differential (optional)
Rear axle	Oscillating	Oscillating	Oscillating
Oscillation with 17.5 tires	± 13 degrees	–	–
Oscillation with 20.5 tires	± 11 degrees	± 11 degrees	± 11 degrees
Traction aid	Limited slip differential optional	Limited slip differential optional	Limited slip differential optional
Brakes			
Service brakes	Inboard wet disc	Inboard wet disc	Outboard wet disc
Park brake	Spring applied hydraulically released	Spring applied hydraulically released	Spring applied hydraulically released

Tires

	924K	930K	938K
17.5 R25, radial (L-2)	Yes		
17.5 R25, radial (L-3)	Yes		
17.5 R25, radial (L-5)	Yes		
20.5-25, 12PR (L-2)	Yes	Yes	Yes
20.5-25, 12PR (L-3)	Yes	Yes	Yes
20.5-25, 16PR (L-5)	Yes	Yes	Yes
20.5 R25, radial (L-2)	Yes	Yes	Yes
20.5 R25, radial (L-3)*	Yes	Yes	Yes
20.5 R25, radial (L-5)	Yes	Yes	Yes
550/65 R25, radial (L-3)	Yes		
600/65 R25, radial (L-3)		Yes	
650/65 R25, radial (L-3)			Yes
Skidder/Agriculture	Yes	Yes	Yes
Flexports Gen II	Yes	Yes	Yes

*Standard tire.

- Other tire choices available, contact your Cat dealer for details. Not all tires are available in all regions.
- In certain applications, the loader's productive capabilities may exceed the tires' tonnes-km/h (ton-mph) capabilities.
- Caterpillar recommends that you consult a tire supplier to evaluate all conditions before selecting a tire model.

Cab



- ROPS: SAE J1040 MAY94, ISO 3471-1994.
- FOPS: SAE J/ISO 3449 APR98, Level II, ISO 3449 1992 Level II.
- Cat cab and Rollover Protective Structures (ROPS) are standard.
- Semi-cab option is available.
- The typical dynamic operator sound pressure level is 71 dB(A) when ISO 6396:2008 is used to measure the value for an enclosed cab. The measurement was conducted at 70% of the maximum engine cooling fan speed. The sound level may vary at different engine cooling fan speeds. The cab was properly installed and maintained. The measurement was conducted with the cab doors and the cab windows closed. The cab was properly installed and maintained.

**The measurements were conducted with the cab doors and windows closed and at 70% of the maximum engine cooling fan speed. The sound level may vary at different engine cooling fan speeds.

Operating Specifications

	924K		930K		938K	
Tipping load – straight (ISO 14397-1)	8732 kg	19,252 lb	9908 kg	21,844 lb	11 385 kg	25,100 lb
Tipping load – full turn (ISO 14397-1)	7488 kg	16,508 lb	8477 kg	18,689 lb	9698 kg	21,380 lb
Clearance: full lift and 45° dump	2772 mm	9'1"	2855 mm	9'4"	2869 mm	9'5"
Reach: full lift and 45° dump	1016 mm	3'4"	1033 mm	3'5"	1108 mm	3'8"
Steering articulation angle each direction	40°		40°		40°	

924K, 930K, 938K Wheel Loader Specifications

Dimensions with Bucket

All dimensions are approximate. Dimensions will vary with bucket and tire choice. Refer to Operating Specifications with Buckets.

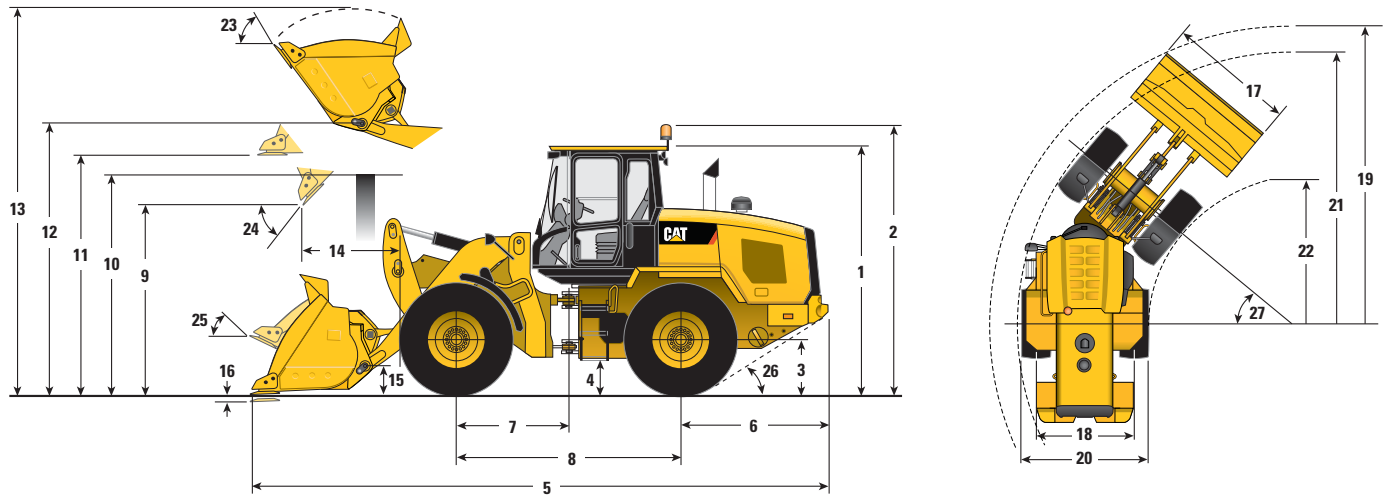

Standard Lift

	924K		930K		938K	
** 1 Height: ground to cab	3340 mm	10'11"	3340 mm	10'11"	3340 mm	10'11"
** 2 Height: ground to beacon	3669 mm	12'0"	3669 mm	12'0"	3669 mm	12'0"
** 3 Height: ground axle center	685 mm	2'2"	685 mm	2'2"	685 mm	2'2"
** 4 Height: ground clearance	397 mm	1'3"	397 mm	1'3"	286 mm	1'3"
* 5 Length: overall	7374 mm	24'2"	7488 mm	24'6"	7604 mm	24'11"
6 Length: rear axle to bumper	1986 mm	6'6"	1993 mm	6'6"	1968 mm	6'5"
7 Length: hitch to front axle	1500 mm	4'11"	1500 mm	4'11"	1525 mm	5'0"
8 Length: wheel base	3000 mm	9'10"	3000 mm	9'10"	3050 mm	10'0"
* 9 Clearance: bucket at 45°	2857 mm	9'4"	2855 mm	9'4"	2869 mm	9'4"
** 10 Clearance: load over height	3308 mm	10'10"	3331 mm	10'11"	3354 mm	11'0"
** 11 Clearance: level bucket	3526 mm	11'6"	3580 mm	11'8"	3642 mm	11'11"
** 12 Height: bucket pin	3853 mm	12'7"	3907 mm	12'9"	3969 mm	13'0"
** 13 Height: overall	4997 mm	16'4"	5122 mm	16'9"	5242 mm	17'2"
* 14 Reach: bucket at 45°	950 mm	3'1"	1033 mm	3'4"	1108 mm	3'7"
15 Carry height: bucket pin	447 mm	1'5"	458 mm	1'6"	467 mm	1'6"
** 16 Dig depth	100 mm	3.9"	100 mm	3.9"	100 mm	3.9"
17 Width: bucket	2550 mm	8'4"	2550 mm	8'4"	2750 mm	9'0"
18 Width: tread center	1930 mm	6'3"	1930 mm	6'3"	2065 mm	6'9"
19 Turning radius: over bucket	5903 mm	19'4"	5933 mm	19'5"	6117 mm	20'0"
20 Width: over tires	2540 mm	8'4"	2540 mm	8'4"	2675 mm	8'9"
21 Turning radius: outside of tires	5402 mm	17'8"	5402 mm	17'8"	5537 mm	18'1"
22 Turning radius: inside of tires	2851 mm	9'4"	2851 mm	9'4"	2852 mm	9'4"
23 Rack angle at full lift		53°		54°		54°
24 Dump angle at full lift		50°		49°		49°
25 Rack angle at carry		43°		45°		45°
26 Departure angle		33°		33°		33°
27 Articulation angle		40°		40°		40°

Operating weight 11 550 kg 25,464 lb 13 135 kg 28,958 lb 15 146 kg 33,391 lb

*Vary with bucket.

**Vary with tire.

Dimensions listed are for a machine configured with general purpose pin on bucket, bolt-on cutting edge, heavy counterweights, 80 kg (176 lb) operator and Michelin 20.5 R25 (L-3) XHA2 tires.

Dimensions with Bucket

	High Lift			
	930K		938K	
** 1 Height: ground to cab	3340 mm	10'11"	3340 mm	10'11"
** 2 Height: ground to beacon	3669 mm	12'0"	3669 mm	12'0"
** 3 Height: ground axle center	685 mm	2'2"	685 mm	2'2"
** 4 Height: ground clearance	397 mm	1'3"	386 mm	1'3"
* 5 Length: overall	8282 mm	27'2"	8344 mm	27'4"
6 Length: rear axle to bumper	1993 mm	6'6"	1968 mm	6'5"
7 Length: hitch to front axle	1500 mm	4'11"	1525 mm	5'0"
8 Length: wheel base	3000 mm	9'10"	3050 mm	10'0"
* 9 Clearance: bucket at 45°	3448 mm	11'3"	3450 mm	11'3"
** 10 Clearance: load over height	3540 mm	11'7"	3561 mm	11'8"
** 11 Clearance: level bucket	4173 mm	13'8"	4223 mm	13'10"
** 12 Height: bucket pin	4500 mm	14'9"	4550 mm	14'11"
** 13 Height: overall	5715 mm	18'8"	5823 mm	19'1"
* 14 Reach: bucket at 45°	1353 mm	4'5"	1374 mm	4'6"
15 Carry height: bucket pin	692 mm	2'3"	686 mm	2'2"
** 16 Dig depth	135 mm	5.3"	135 mm	5.3"
17 Width: bucket	2550 mm	8'4"	2750 mm	9'0"
18 Width: tread center	1930 mm	6'3"	2065 mm	6'9"
19 Turning radius: over bucket	6315 mm	20'8"	6472 mm	21'2"
20 Width: over tires	2540 mm	8'4"	2675 mm	8'9"
21 Turning radius: outside of tires	5402 mm	17'8"	5537 mm	18'1"
22 Turning radius: inside of tires	2851 mm	9'4"	2852 mm	9'4"
23 Rack angle at full lift		53°		53°
24 Dump angle at full lift		48°		47°
25 Rack angle at carry		51°		50°
26 Departure angle		33°		33°
27 Articulation angle		40°		40°
Operating weight	13 382 kg	29,502 lb	15 395 kg	33,940 lb

*Vary with bucket.

**Vary with tire.



Dimensions listed are for a machine configured with general purpose pin on bucket, bolt-on cutting edge, heavy counterweights, 80 kg (176 lb) operator and Michelin 20.5 R25 (L-3) XHA2 tires.

Supplemental Operating Data – Tires

	924K				930K				938K			
	20.5-25 12 PR		17.5 R25 (L-2)		20.5-25 16 PR		20.5R25 (L-5)		650/65 R25		20.5 L-5	
	mm	in	mm	in	mm	in	mm	in	mm	in	mm	in
Vertical heights	-22	-0.9"	-96	-3.8"	-25	-2.1"	+15	+0.6"	-35	-1.4"	+15	+0.6"
Reach: bucket at 45°	-6	-0.2"	+73	+2.9"	-3	-0.1"	-21	-0.8"	-5	-0.2"	-22	-0.8"
Width: over tires	-38	-1.5"	+0	+0"	+38	+1.5"	+0	+0"	+121	+4.8"	+65	+2.6"
Turning radius: outside of tires	-11	-0.4"	-45	-1.8"	+42	+1.7"	+1	+0"	+53	+2.1"	+61	+2.4"
Turning radius: inside of tires	-11	-0.4"	+35	+1.4"	+0	+0"	+0	+0"	-61	-2.4"	-33	-1.3"
	kg	lb	kg	lb	kg	lb	kg	lb	kg	lb	kg	lb
Tipping load – straight	-190	-419	-217	-478	-166	-366	+444	+979	+329	+725	+441	+972
Tipping load – full turn	-164	-362	-187	-412	-144	-317	+384	+847	+285	+628	+381	+840
Operating weight	-282	-622	-40	-88	-254	-560	+678	+1,495	+506	+1,115	+678	+1,495

Bucket Specifications

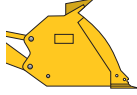
924K Operating Specifications with Buckets



		General Purpose								
		 Pin On			 Fusion			 ISO 23727		
Rated capacity	m ³	1.7	1.9	2.1	1.9	2.1	2.3	2.1	2.3	
	yd ³	2.2	2.5	2.7	2.5	2.7	3.0	2.7	3.0	
Struck capacity	m ³	1.3	1.7	1.9	1.7	1.9	2.1	2.0	2.2	
	yd ³	1.7	2.2	2.5	2.2	2.5	2.7	2.6	2.9	
Width: bucket	mm	2550	2550	2550	2550	2550	2550	2550	2550	
	ft/in	8'4"	8'4"	8'4"	8'4"	8'4"	8'4"	8'4"	8'4"	
Nominal material density, 100% fill factor	kg/m ³	2311	2043	1835	1948	1744	1576	1676	1515	
	lb/yd ³	3,936	3,423	3,146	3,262	2,989	2,663	2,874	2,560	
Clearance: full lift, 45° dump	mm	2915	2857	2801	2830	2773	2725	2693	2643	
	ft/in	9'6"	9'4"	9'2"	9'3"	9'1"	8'11"	8'10"	8'8"	
Reach: full lift, 45° dump	mm	882	950	990	982	1022	1059	1126	1162	
	ft/in	2'10"	3'1"	3'2"	3'2"	3'4"	3'5"	3'8"	3'9"	
Reach: 2130 mm (7'0") clearance, 45° dump	mm	1440	1480	1492	1499	1509	1520	1568	1575	
	ft/in	4'8"	4'10"	4'10"	4'11"	4'11"	4'11"	5'1"	5'1"	
Reach: level arm, level bucket	mm	2142	2231	2303	2273	2345	2408	2476	2539	
	ft/in	7'0"	7'3"	7'6"	7'5"	7'8"	7'10"	8'1"	8'3"	
Dig depth	mm	100	100	100	100	100	100	93	93	
	in	3.9"	3.9"	3.9"	3.9"	3.9"	3.9"	3.7"	3.7"	
Length: overall	mm	7284	7374	7446	7416	7588	7551	7613	7676	
	ft/in	23'10"	24'2"	24'5"	24'3"	24'10"	24'9"	24'11"	25'2"	
Height: overall	mm	5002	4997	5068	5022	5093	5151	5182	5240	
	ft/in	16'4"	16'4"	16'7"	16'5"	16'8"	16'10"	17'0"	17'2"	
Turning radius, bucket at carry	mm	5297	5903	5925	5916	5938	5957	5959	5980	
	ft/in	17'4"	19'4"	19'5"	19'4"	19'5"	19'6"	19'6"	19'7"	
Tipping load – straight, ISO 14397-1*	kg	9153	9053	8990	8667	8583	8503	8252	8174	
	lb	20,179	19,958	19,820	19,107	18,922	18,746	18,192	18,019	
Tipping load – straight, rigid tire**	kg	9535	9430	9364	9028	8940	8857	8596	8514	
	lb	21,021	20,790	20,644	19,903	19,709	19,526	18,950	18,770	
Tipping load – full turn, ISO 14397-1*	kg	7858	7765	7708	7401	7323	7250	7040	6968	
	lb	17,324	17,119	16,993	16,316	16,144	15,984	15,521	15,362	
Tipping load – full turn, rigid tire**	kg	8360	8260	8199	7874	7791	7713	7490	7413	
	lb	18,431	18,210	18,076	17,359	17,176	17,004	16,512	16,343	
Breakout force	kg	12 273	10 342	9645	9893	9238	8725	8174	7756	
	lb	27,057	22,800	21,264	21,810	20,366	19,235	18,020	17,098	
Operating weight	kg	11 966	12 019	12 038	12 361	12 405	12 443	12 352	12 390	
	lb	26,381	26,497	28,539	27,251	27,348	27,432	27,231	27,315	

*Full compliance to ISO 14397-1 (2007) Sections 1 through 6, which requires 2% verification between calculation and testing.

**Compliance to ISO 14397-1 (2007) Sections 1 through 5.

Dimensions listed are for a 924K configured with bucket, bolt-on cutting edge, heavy counterweights, 80 kg (176 lb) operator, and Michelin 20.5 R25 (L-3) XHA2 tires at a pressure of 4.14 bar (60 psi) in the front tires and 2.76 bar (40 psi) in the rear tires.

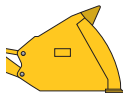
924K Operating Specifications with Buckets

		Light Material			
		 Pin On		 Fusion	
Rated capacity	m ³	3.5	4.2	3.5	4.2
	yd ³	4.6	5.5	4.6	5.5
Struck capacity	m ³	3.3	4.0	3.3	4.0
	yd ³	4.3	5.2	4.3	5.2
Width: bucket	mm	2750	2750	2750	2750
	ft/in	9'0"	9'0"	9'0"	9'0"
Nominal material density, 100% fill factor	kg/m ³	1028	827	977	785
	lb/yd ³	1723	1391	1638	1321
Clearance: full lift, 45° dump	mm	2575	2455	2545	2425
	ft/in	8'5"	8'0"	8'4"	7'11"
Reach: full lift, 45° dump	mm	1094	1214	1124	1244
	ft/in	3'7"	3'11"	3'8"	4'0"
Reach: 2130 mm (7'0") clearance, 45° dump	mm	1463	1499	1473	1506
	ft/in	4'9"	4'11"	4'9"	4'11"
Reach: level arm, level bucket	mm	2556	2726	2598	2768
	ft/in	8'4"	8'11"	8'6"	9'0"
Dig depth	mm	100	100	100	100
	in	3.9"	3.9"	3.9"	3.9"
Length: overall	mm	7699	7869	7741	7911
	ft/in	25'3"	25'9"	25'4"	25'11"
Height: overall	mm	5229	5390	5254	5417
	ft/in	17'1"	17'8"	17'2"	17'9"
Turning radius, bucket at carry	mm	6094	6148	6107	6163
	ft/in	19'11"	20'2"	20'0"	20'2"
Tipping load – straight, ISO 14397-1*	kg	8442	8172	8064	7799
	lb	18,611	18,016	17,778	17,193
Tipping load – straight, rigid tire**	kg	8794	8513	8400	8124
	lb	19,387	18,768	18,519	17,910
Tipping load – full turn, ISO 14397-1*	kg	7194	6945	6836	6593
	lb	15,860	15,311	15,071	14,535
Tipping load – full turn, rigid tire**	kg	7653	7388	7273	7013
	lb	16,872	16,288	16,034	15,461
Breakout force	kg	7626	6660	7439	6433
	lb	16,812	14,683	16,400	14,182
Operating weight	kg	12 418	12 555	12 768	12 908
	lb	27,377	27,679	28,149	28,457

*Full compliance to ISO 14397-1 (2007) Sections 1 through 6, which requires 2% verification between calculation and testing.

**Compliance to ISO 14397-1 (2007) Sections 1 through 5.

Dimensions listed are for a 924K configured with bucket, bolt-on cutting edge, heavy counterweights, 80 kg (176 lb) operator, and Michelin 20.5 R25 (L-3) XHA2 tires at a pressure of 4.14 bar (60 psi) in the front tires and 2.76 bar (40 psi) in the rear tires.

Bucket Specifications

924K Bucket Selection Table

Bucket Fill Factor		kg/m ³	1450	1525	1600	1675	1750	1825	1900	1975	2050	2125	2200	2275	2350	
		lb/yd ³	2,443	2,570	2,696	2,822	2,949	3,075	3,202	3,328	3,454	3,581	3,707	3,833	3,960	
		m ³	yd ³													
General Purpose	Pin On	1.7	2.2									113%	109%	105%	102%	98%
		1.9	2.5						112%	108%	103%	100%	96%			
		2.1	2.7				115%	110%	105%	101%	97%					
	Fusion	1.9	2.5					111%	107%	103%	99%	95%				
		2.1	2.7			114%	109%	104%	100%	96%						
		2.3	3.0	109%	103%	99%	94%									

Bucket Fill Factor		kg/m ³	650	700	750	800	850	900	950	1000	1050	1100	1150	1200	1250	
		lb/yd ³	1,095	1,180	1,264	1,348	1,432	1,517	1,601	1,685	1,769	1,854	1,938	2,022	2,106	
		m ³	yd ³													
Light Material	Pin On	3.5	4.6					114%	108%	103%	98%					
		4.2	5.5			110%	103%	97%								
	Fusion	3.5	4.6					115%	109%	103%	98%					
		4.2	5.5			112%	105%	98%								

Material density and fill factor are key variables when choosing the appropriate size of the bucket. The long floor and open throat design of the Performance Series Buckets along with the aggressive rack angles of the optimized K Series linkage will demonstrate fill factors greater than 100% ISO rated. Refer to the Fill Factors table for expected fill factor per material density and Bucket Selection Table for bucket sizing.



924K Fill Factors

Materials	Density	Fill %
Earth and rock	~ 1800 kg/m ³	~ 3,033 lb/yd ³
Sand and gravel	~ 1700 kg/m ³	~ 2,865 lb/yd ³
Aggregates	~ 1600 kg/m ³	~ 2,696 lb/yd ³
Bulk grains	~ 750 kg/m ³	~ 1,264 lb/yd ³
Woodchips	~ 500 kg/m ³	~ 843 lb/yd ³

924K Ground Engagement Options

	Long Teeth and Segments		Short Teeth and Segments	
Dig depth	+12 mm	+0.5 in	+5 mm	+0.2 in
Length: overall	+146 mm	+5.7 in	+121 mm	+4.8 in
Dump clearance	-103 mm	-4.1 in	-82 mm	-3.2 in
Reach	+104 mm	+4.1 in	+89 mm	+3.5 in
Tipping load – straight	-148 kg	-326 lb	-142 kg	-313 lb
Tipping load – full turn	-145 kg	-320 lb	-139 kg	-306 lb
Breakout force	-121 kg	-267 lb	-115 kg	-254 lb
Operating weight	+120 kg	+265 lb	+116 kg	+256 lb

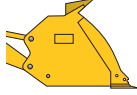
930K Operating Specifications with Buckets

		General Purpose								
		 Pin On			 Fusion			 ISO 23727		
Rated capacity	m ³	2.1	2.3	2.5	2.1	2.3	2.5	2.3	2.5	
	yd ³	2.7	3.0	3.3	2.7	3.0	3.3	3.0	3.3	
Struck capacity	m ³	1.9	2.1	2.3	1.9	2.1	2.3	2.2	2.4	
	yd ³	2.5	2.7	3.0	2.5	2.7	3.0	2.9	3.1	
Width: bucket	mm	2550	2550	2550	2550	2550	2550	2550	2750	
	ft/in	8'4"	8'4"	8'4"	8'4"	8'4"	8'4"	8'4"	9'0"	
Nominal material density, 100% fill factor	kg/m ³	2018	1821	1649	1925	1741	1579	1674	1521	
	lb/yd ³	3,460	3,076	2,754	3,299	2,941	2,637	2,829	2,540	
Clearance: full lift, 45° dump	mm	2855	2807	2761	2828	2779	2733	2698	2698	
	ft/in	9'4"	9'2"	9'0"	9'3"	9'1"	8'11"	8'10"	8'10"	
Reach: full lift, 45° dump	mm	1033	1070	1109	1064	1102	1140	1205	1205	
	ft/in	3'4"	3'6"	3'7"	3'5"	3'7"	3'8"	3'11"	3'11"	
Reach: 2130 mm (7'0") clearance, 45° dump	mm	1560	1573	1587	1578	1590	1603	1648	1648	
	ft/in	5'1"	5'1"	5'2"	5'2"	5'2"	5'3"	5'4"	5'4"	
Reach: level arm, level bucket	mm	2350	2413	2475	2392	2455	2517	2586	2586	
	ft/in	7'8"	7'11"	8'1"	7'10"	8'0"	8'3"	8'5"	8'5"	
Dig depth	mm	100	100	100	100	100	100	93	93	
	in	3.9"	3.9"	3.9"	3.9"	3.9"	3.9"	3.7"	3.7"	
Length: overall	mm	7488	7551	7613	7530	7593	7655	7718	7718	
	ft/in	24'6"	24'9"	24'11"	24'8"	24'10"	25'1"	25'3"	25'3"	
Height: overall	mm	5122	5180	5239	5147	5205	5264	5294	5294	
	ft/in	16'9"	16'11"	17'2"	16'10"	17'0"	17'3"	17'4"	17'4"	
Turning radius, bucket at carry	mm	5933	5951	5970	5945	5964	5983	5984	6075	
	ft/in	19'5"	19'6"	19'7"	19'6"	19'6"	19'7"	19'7"	19'11"	
Tipping load – straight, ISO 14397-1*	kg	9908	9798	9661	9490	9406	9288	9049	8952	
	lb	21,843	21,601	21,299	20,922	20,737	20,477	19,950	19,736	
Tipping load – straight, rigid tire**	kg	10 321	10 206	10 064	9886	9798	9675	9426	9325	
	lb	22,864	22,500	22,187	21,795	21,601	21,330	20,781	20,558	
Tipping load – full turn, ISO 14397-1*	kg	8477	8375	8246	8083	8007	7896	7702	7607	
	lb	18,689	18,464	18,179	17,820	17,652	17,408	16,980	16,771	
Tipping load – full turn, rigid tire**	kg	9018	8909	8772	8599	8518	8400	8193	8093	
	lb	19,881	19,641	19,339	18,958	18,779	18,519	18,062	17,842	
Breakout force	kg	12 891	12 158	11 488	12 366	11 693	11 076	10 432	10 375	
	lb	28,420	26,804	25,327	27,262	25,779	24,418	22,999	22,873	
Operating weight	kg	13 135	13 198	13 297	13 501	13 539	13 621	13 487	13 590	
	lb	28,958	29,097	29,315	29,765	29,848	30,029	29,734	29,961	

*Full compliance to ISO 14397-1 (2007) Sections 1 through 6, which requires 2% verification between calculation and testing.

**Compliance to ISO 14397-1 (2007) Sections 1 through 5.

Dimensions listed are for a 930K configured with bucket, bolt-on cutting edge, heavy counterweights, 80 kg (176 lb) operator, and Michelin 20.5 R25 (L-3) XHA2 tires at a pressure of 4.14 bar (60 psi) in the front tires and 2.76 bar (40 psi) in the rear tires.

Bucket Specifications

930K Operating Specifications with Buckets

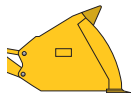
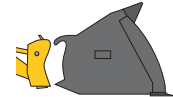
		Light Material				High Lift
		 Pin On		 Fusion		
Rated capacity	m ³	4.2	5.0	4.2	5.0	–
	yd ³	5.5	6.5	5.5	6.5	–
Struck capacity	m ³	4.0	4.8	4.0	4.8	–
	yd ³	5.2	6.3	5.2	6.3	–
Width: bucket	mm	2750	2750	2750	2750	–
	ft/in	9'0"	9'0"	9'0"	9'0"	–
Nominal material density, 100% fill factor	kg/m ³	915	765	872	730	–
	lb/yd ³	1,540	1,298	1,468	1,237	–
Clearance: full lift, 45° dump	mm	2509	2509	2479	2479	+593
	ft/in	8'2"	8'2"	8'1"	8'1"	+1'11"
Reach: full lift, 45° dump	mm	1257	1257	1286	1286	+320
	ft/in	4'1"	4'1"	4'2"	4'2"	+1'0"
Reach: 2130 mm (7'0") clearance, 45° dump	mm	1579	1579	1588	1588	+717
	ft/in	5'2"	5'2"	5'2"	5'2"	+2'4"
Reach: level arm, level bucket	mm	2773	2773	2815	2815	+653
	ft/in	9'1"	9'1"	9'2"	9'2"	+2'1"
Dig depth	mm	100	100	100	100	+35
	in	3.9"	3.9"	3.9"	3.9"	+1.4"
Length: overall	mm	7911	7911	7953	7953	+794
	ft/in	25'11"	25'11"	26'1"	26'1"	+2'7"
Height: overall	mm	5445	5725	5471	5752	+593
	ft/in	17'10"	18'9"	17'11"	18'10"	+1'11"
Turning radius, bucket at carry	mm	6152	6152	6166	6166	+384
	ft/in	20'2"	20'2"	20'2"	20'2"	+1'3"
Tipping load – straight, ISO 14397-1*	kg	9059	9028	8675	8646	–2741
	lb	19,972	19,903	19,125	19,061	–6,043
Tipping load – straight, rigid tire**	kg	9436	9404	9036	9006	–2855
	lb	20,803	20,732	19,921	19,855	–6,294
Tipping load – full turn, ISO 14397-1*	kg	7688	7655	7326	7295	–2402
	lb	16,949	16,876	16,151	16,061	–5,296
Tipping load – full turn, rigid tire**	kg	8178	8143	7794	7761	–2555
	lb	18,029	17,952	17,183	17,110	–5,633
Breakout force	kg	9020	8969	8730	8682	–299
	lb	19,886	19,773	19,246	19,141	–659
Operating weight	kg	13 651	13 721	14 004	14 069	+247
	lb	30,095	30,250	30,874	31,017	+545

*Full compliance to ISO 14397-1 (2007) Sections 1 through 6, which requires 2% verification between calculation and testing.

**Compliance to ISO 14397-1 (2007) Sections 1 through 5.

Dimensions listed are for a 930K configured with bucket, bolt-on cutting edge, heavy counterweights, 80 kg (176 lb) operator, and Michelin 20.5 R25 (L-3) XHA2 tires at a pressure of 4.14 bar (60 psi) in the front tires and 2.76 bar (40 psi) in the rear tires.

930K Bucket Selection Table

Bucket Fill Factor		kg/m ³	1375	1450	1525	1600	1675	1750	1825	1900	1975	2050	2125	High Lift		
		lb/yd ³	2,317	2,443	2,570	2,696	2,822	2,949	3,075	3,202	3,328	3,454	3,581			
		m ³	yd ³											kg/m ³	lb/yd ³	
General Purpose	Pin On	2.1	2.7						111%	106%	102%	98%	95%	-576	-971	
		2.3	3.0				114%	109%	104%	100%	96%			-522	-880	
		2.5	3.3	114%	108%	103%	98%	94%						-477	-804	
	Fusion	2.1	2.7					115%	110%	105%	101%	97%			-568	-957
		2.3	3.0			114%	109%	104%	99%	95%				-515	-867	
		2.5	3.3	115%	109%	104%	99%	94%						-470	-792	

Bucket Fill Factor		kg/m ³	650	700	750	800	850	900	950	1000	1050	1100	1150	High Lift		
		lb/yd ³	1,095	1,180	1,264	1,348	1,432	1,517	1,601	1,685	1,769	1,854	1,938			
		m ³	yd ³											kg/m ³	lb/yd ³	
Light Material	Pin On	4.2	5.5				114%	108%	102%	96%					-272	-458
		5.0	6.5	109%	102%	96%						-229	-387			
	Fusion	4.2	5.5					109%	103%	97%					-269	-452
		5.0	6.5	112%	104%	97%						-226	-382			

Material density and fill factor are key variables when choosing the appropriate size of the bucket. The long floor and open throat design of the Performance Series Buckets along with the aggressive rack angles of the optimized K Series linkage will demonstrate fill factors greater than 100% ISO rated. Refer to the Fill Factors table for expected fill factor per material density and Bucket Selection Table for bucket sizing.

930K Fill Factors



Materials	Density	Fill %
Earth and rock	~ 1800 kg/m ³	~ 3,033 lb/yd ³
Sand and gravel	~ 1700 kg/m ³	~ 2,865 lb/yd ³
Aggregates	~ 1600 kg/m ³	~ 2,696 lb/yd ³
Bulk grains	~ 750 kg/m ³	~ 1,264 lb/yd ³
Woodchips	~ 500 kg/m ³	~ 843 lb/yd ³

930K Ground Engagement Options

	Long Teeth and Segments		Short Teeth and Segments	
Dig depth	+11 mm	+0.4 in	+5 mm	+0.2 in
Length: overall	+146 mm	+5.7 in	+121 mm	+4.8 in
Dump clearance	-104 mm	-4.1 in	-83 mm	-3.3 in
Reach	+103 mm	+4.1 in	+88 mm	+3.5 in
Tipping load – straight	-150 kg	-331 lb	-143 kg	-315 lb
Tipping load – full turn	-146 kg	-322 lb	-140 kg	-309 lb
Breakout force	-121 kg	-267 lb	-115 kg	-254 lb
Operating weight	+120 kg	+265 lb	+116 kg	+256 lb

Bucket Specifications

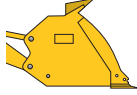
938K Operating Specifications with Buckets

		General Purpose								
		 Pin On			 Fusion			 ISO 23727		
Rated capacity	m ³	2.5	2.7	2.9	2.5	2.7	2.9	2.7	2.9	
	yd ³	3.3	3.5	3.8	3.3	3.5	3.8	3.5	3.8	
Struck capacity	m ³	2.3	2.5	2.7	2.3	2.5	2.7	2.6	2.7	
	yd ³	3.0	3.3	3.5	3.0	3.3	3.5	3.4	3.5	
Width: bucket	mm	2750	2750	2750	2750	2750	2750	2750	2750	
	ft/in	9'0"	9'0"	9'0"	9'0"	9'0"	9'0"	9'0"	9'0"	
Nominal material density, 100% fill factor	kg/m ³	1940	1780	1644	1848	1695	1566	1644	1519	
	lb/yd ³	3,238	3,026	2,766	3,085	2,881	2,633	2,795	2,555	
Clearance: full lift, 45° dump	mm	2869	2822	2786	2834	2787	2751	2712	2675	
	ft/in	9'4"	9'3"	9'1"	9'3"	9'1"	9'0"	8'10"	8'9"	
Reach: full lift, 45° dump	mm	1108	1146	1178	1146	1185	1216	1280	1311	
	ft/in	3'7"	3'9"	3'10"	3'9"	3'10"	3'11"	4'2"	4'3"	
Reach: 2130 mm (7'0") clearance, 45° dump	mm	1637	1652	1664	1658	1672	1684	1726	1735	
	ft/in	5'4"	5'5"	5'5"	5'5"	5'5"	5'6"	5'7"	5'8"	
Reach: level arm, level bucket	mm	2452	2514	2563	2504	2566	2615	2687	2736	
	ft/in	8'0"	8'2"	8'4"	8'2"	8'5"	8'6"	8'9"	8'11"	
Dig depth	mm	100	100	100	101	101	101	93	93	
	in	3.9"	3.9"	3.9"	4"	4"	4"	3.7"	3.7"	
Length: overall	mm	7604	7666	7715	7656	7718	7767	7833	7882	
	ft/in	24'11"	25'1"	25'3"	25'1"	25'3"	25'5"	25'8"	25'10"	
Height: overall	mm	5242	5301	5348	5273	5332	5379	5415	5462	
	ft/in	17'2"	17'4"	17'6"	17'3"	17'5"	17'7"	17'9"	17'11"	
Turning radius, bucket at carry	mm	6117	6136	6150	6133	6152	6166	6169	6185	
	ft/in	20'0"	20'1"	20'2"	20'1"	20'2"	20'2"	20'2"	20'3"	
Tipping load – straight, ISO 14397-1*	kg	11 385	11 290	11 209	10 892	10 798	10 720	10 470	10 398	
	lb	25,100	24,890	24,712	24,013	23,806	23,634	23,082	22,924	
Tipping load – straight, rigid tire**	kg	11 859	11 760	11 676	11 346	11 248	11 167	10 907	10 832	
	lb	26,145	25,926	25,741	25,014	24,798	24,619	24,046	23,880	
Tipping load – full turn, ISO 14397-1*	kg	9698	9610	9537	9238	9151	9080	8878	8812	
	lb	21,380	21,186	21,025	20,366	20,175	20,018	19,573	19,427	
Tipping load – full turn, rigid tire**	kg	10 317	10 224	10 145	9827	9735	9660	9445	9375	
	lb	22,745	22,540	22,366	21,665	21,462	21,297	20,823	20,668	
Breakout force	kg	13 813	13 082	12 552	13 170	12 498	12 009	11 299	10 887	
	lb	30,452	28,841	27,672	29,035	27,553	26,475	24,910	24,002	
Operating weight	kg	15 146	15 191	15 228	15 551	15 595	15 631	15 481	15 515	
	lb	33,391	33,490	33,572	34,284	34,381	34,460	34,130	34,205	

*Full compliance to ISO 14397-1 (2007) Sections 1 through 6, which requires 2% verification between calculation and testing.

**Compliance to ISO 14397-1 (2007) Sections 1 through 5.

Dimensions listed are for a 938K configured with bucket, bolt-on cutting edge, heavy counterweights, 80 kg (176 lb) operator, and Michelin 20.5 R25 (L-3) XHA2 tires at a pressure of 4.48 bar (65 psi) in the front tires and 2.76 bar (40 psi) in the rear tires.

938K Operating Specifications with Buckets

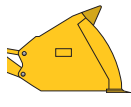
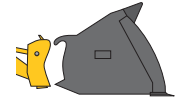
		Light Material				High Lift
		 Pin On		 Fusion		
Rated capacity	m ³	4.2	5.0	4.2	5.0	–
	yd ³	5.5	6.5	5.5	6.5	–
Struck capacity	m ³	4.0	4.8	4.0	4.8	–
	yd ³	5.2	6.3	5.2	6.3	–
Width: bucket	mm	2750	2750	2750	2750	–
	ft/in	9'0"	9'0"	9'0"	9'0"	–
Nominal material density, 100% fill factor	kg/m ³	1080	905	1029	861	–
	lb/yd ³	1,818	1,535	1,731	1,460	–
Clearance: full lift, 45° dump	mm	2571	2571	2534	2534	+581
	ft/in	8'5"	8'5"	8'3"	8'3"	+1'10"
Reach: full lift, 45° dump	mm	1294	1294	1331	1331	+267
	ft/in	4'2"	4'2"	4'4"	4'4"	+11"
Reach: 2130 mm (7'0") clearance, 45° dump	mm	1654	1654	1666	1666	+666
	ft/in	5'5"	5'5"	5'5"	5'5"	+2'2"
Reach: level arm, level bucket	mm	2812	2812	2864	2864	+607
	ft/in	9'2"	9'2"	9'4"	9'4"	+1'11"
Dig depth	mm	100	100	101	101	+35
	in	3.9"	3.9"	4"	4"	+1.4"
Length: overall	mm	7964	7964	8016	8016	+740
	ft/in	26'1"	26'1"	26'3"	26'3"	+2'5"
Height: overall	mm	5507	5786	5539	5820	+581
	ft/in	18'0"	18'11"	18'2"	19'1"	+1'10"
Turning radius, bucket at carry	mm	6227	6227	6244	6244	+357
	ft/in	20'5"	20'5"	20'5"	20'5"	+1'2"
Tipping load – straight, ISO 14397-1*	kg	10 705	10 688	10 241	10 217	–2951
	lb	23,600	23,563	22,578	22,525	–6,506
Tipping load – straight, rigid tire**	kg	11 151	11 134	10 668	10 643	–3074
	lb	24,584	24,546	23,519	23,464	–6,777
Tipping load – full turn, ISO 14397-1*	kg	9073	9054	8640	8614	–2577
	lb	20,003	19,961	19,048	18,991	–5,681
Tipping load – full turn, rigid tire**	kg	9653	9632	9192	9164	–2741
	lb	21,281	21,235	20,265	20,203	–6,043
Breakout force	kg	10 331	10 281	9936	9888	–502
	lb	22,776	22,666	21,905	21,799	–1,107
Operating weight	kg	15 493	15 560	15 894	15 959	+249
	lb	34,156	34,304	35,040	35,184	+549

*Full compliance to ISO 14397-1 (2007) Sections 1 through 6, which requires 2% verification between calculation and testing.

**Compliance to ISO 14397-1 (2007) Sections 1 through 5.

Dimensions listed are for a 938K configured with bucket, bolt-on cutting edge, heavy counterweights, 80 kg (176 lb) operator, and Michelin 20.5 R25 (L-3) XHA2 tires at a pressure of 4.48 bar (65 psi) in the front tires and 2.76 bar (40 psi) in the rear tires.

Bucket Specifications

938K Bucket Selection Table

Bucket Fill Factor		kg/m ³	1375	1450	1525	1600	1675	1750	1825	1900	1975	2050	2125	High Lift		
		lb/yd ³	2,317	2,443	2,570	2,696	2,822	2,949	3,075	3,202	3,328	3,454	3,581			
		m ³	yd ³											kg/m ³	lb/yd ³	
General Purpose	Pin On	2.5	3.3						111%	106%	102%	98%	95%		-519	-874
		2.7	3.5				111%	106%	102%	98%					-477	-804
		2.9	3.8			113%	108%	103%	98%						-442	-744
	Fusion	2.5	3.3					110%	106%	101%	97%				-509	-858
		2.7	3.5				111%	106%	101%	97%					-468	-789
		2.9	3.8	114%	108%	103%	98%								-433	-730

Bucket Fill Factor		kg/m ³	650	700	750	800	850	900	950	1000	1050	1100	1150	High Lift		
		lb/yd ³	1,095	1,180	1,264	1,348	1,432	1,517	1,601	1,685	1,769	1,854	1,938			
		m ³	yd ³											kg/m ³	lb/yd ³	
Light Material	Pin On	4.2	5.5							114%	108%	103%	98%		-295	-496
		5.0	6.5				113%	107%	101%	95%					-249	-419
	Fusion	4.2	5.5							114%	108%	103%	98%		-290	-488
		5.0	6.5				115%	108%	101%	96%					-245	-412

Material density and fill factor are key variables when choosing the appropriate size of the bucket. The long floor and open throat design of the Performance Series Buckets along with the aggressive rack angles of the optimized K Series linkage will demonstrate fill factors greater than 100% ISO rated. Refer to the Fill Factors table for expected fill factor per material density and Bucket Selection Table for bucket sizing.

938K Fill Factors

Materials	Density	Fill %
Earth and rock	~ 1800 kg/m ³	~ 3,033 lb/yd ³
Sand and gravel	~ 1700 kg/m ³	~ 2,865 lb/yd ³
Aggregates	~ 1600 kg/m ³	~ 2,696 lb/yd ³
Bulk grains	~ 750 kg/m ³	~ 1,264 lb/yd ³
Woodchips	~ 500 kg/m ³	~ 843 lb/yd ³

938K Ground Engagement Options

	Long Teeth and Segments		Short Teeth and Segments	
Dig depth	+12 mm	+0.5 in	+5 mm	+0.2 in
Length: overall	+146 mm	+5.7 in	+121 mm	+4.8 in
Dump clearance	-105 mm	-4.1 in	-84 mm	-3.3 in
Reach	+102 mm	+4 in	+87 mm	+3.4 in
Tipping load – straight	-138 kg	-304 lb	-144 kg	-317 lb
Tipping load – full turn	-135 kg	-298 lb	-141 kg	-311 lb
Breakout force	-112 kg	-247 lb	-115 kg	-254 kg
Operating weight	+111 kg	+245 lb	+116 kg	+256 lb

Sand and Gravel Bucket Specifications

Purpose Built Configuration

Maximize your productivity while keeping your operating costs low. Cat Aggregate Handlers are built for sand and gravel rehandling to maximize your profits.

Sand and Gravel Performance Series Buckets

The buckets feature a longer floor, open throat, curved side bars and additional serviceable wear plates for extended life.

Belly Mounted Counterweight

Additional counterweight improves stability without reducing ground clearance or departure angle to maximize performance.

Aggregate Handler Operating Specifications with Buckets

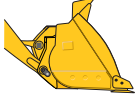
		Pin On Sand and Gravel					
		924K	924K	930K	930K	938K	938K
 Rated capacity	m ³	2.5	2.7	2.7	3.2	3.2	3.5
	yd ³	3.3	3.5	3.5	4.2	4.2	4.6
Struck capacity	m ³	2.1	2.6	2.6	3.0	3.0	3.4
	yd ³	2.7	3.4	3.4	3.9	3.9	4.4
Bucket width	mm	2750	2750	2750	2750	2750	2750
	ft/in	9'0"	9'0"	9'0"	9'0"	9'0"	9'0"
Nominal material density, 100% fill factor	kg/m ³	1521	1385	1629	1366	1579	1371
	lb/yd ³	2,541	2,356	2,771	2,294	2,653	2,300
Clearance: full lift, 45° dump	mm	2753	2706	2761	2724	2786	2663
	ft/in	9'0"	8'10"	9'0"	8'11"	9'1"	8'8"
Reach: full lift, 45° dump	mm	1028	1066	1109	1140	1178	1362
	ft/in	3'4"	3'5"	3'7"	3'8"	3'10"	4'5"
Reach: 2130 mm (7'0") clearance, 45° dump	mm	1504	1516	1587	1598	1664	1779
	ft/in	4'11"	4'11"	5'2"	5'2"	5'5"	5'10"
Reach: level arm, level bucket	mm	2366	2428	2475	2524	2563	2776
	ft/in	7'9"	7'11"	8'1"	8'3"	8'4"	9'1"
Dig depth	mm	100	100	100	100	100	100
	ft/in	3.9"	3.9"	3.9"	3.9"	3.9"	3.9"
Length: overall	mm	7509	7571	7613	7662	7715	7928
	in	24'7"	24'10"	24'11"	25'1"	25'3"	26'0"
Height: overall	mm	5126	5184	5239	5349	5411	5453
	ft/in	16'9"	17'0"	17'2"	17'6"	17'9"	17'10"
Turning radius, bucket at carry	mm	6023	6054	6060	6075	6150	6215
	ft/in	19'9"	19'10"	19'10"	19'11"	20'2"	20'4"
Tipping load – straight, ISO 14397-1*	kg	8890	8757	10 325	10 261	11 890	11 328
	lb	19,599	19,306	22,763	22,622	26,213	24,974
Tipping load – straight, rigid tire**	kg	9260	9121	10 756	10 689	12 385	11 785
	lb	20,415	20,108	23,713	23,565	27,304	25,981
Tipping load – full turn, ISO 14397-1*	kg	7606	7480	8799	8740	10 108	9599
	lb	16,768	16,491	19,398	19,268	22,284	21,162
Tipping load – full turn, rigid tire**	kg	8091	7956	9359	9297	10 752	10 189
	lb	17,838	17,540	20,633	20,496	23,704	22,463
Breakout force	kg	9027	8509	11 430	10 957	12 506	10 435
	lb	19,901	18,759	25,199	24,156	27,571	23,005
Operating weight	kg	12 359	12 450	13 946	13 983	15 842	16 077
	lb	27,247	27,448	30,746	30,827	34,926	25,444

*Full compliance to ISO 14397-1 (2007) Sections 1 through 6, which requires 2% verification between calculation and testing.

**Compliance to ISO 14397-1 (2007) Sections 1 through 5.

Dimensions listed are for machines configured with pin on buckets, bolt-on cutting edges, heavy (924K) or logger (930K and 938K) counterweights, additional guarding, 80 kg (176 lb) operator, and Michelin 20.5 R25 (L-3) XHA2 tires at a pressure of 4.14 bar (60 psi) in the front tires and 2.76 bar (40 psi) in the rear tires.

Operating Specifications

Aggregate Handler Bucket Selection Table

Bucket Fill Factor		kg/m ³	1150	1225	1300	1375	1450	1525	1600	1675	1750	1825	1900
		lb/yd ³	1,938	2,064	2,191	2,317	2,443	2,570	2,696	2,822	2,949	3,075	3,202
		m ³											
		yd ³											
Aggregate Handler	924K	2.5	3.3				111%	105%	100%	95%			
		2.7	3.5		113%	107%	101%	96%					
	930K	2.7	3.5					112%	107%	102%	97%		
		3.2	4.2		111%	105%	99%	94%					
	938K	3.2	4.2				115%	109%	104%	99%	94%		
		3.5	4.6		112%	105%	100%	95%					

Material density and fill factor are key variables when choosing the appropriate size of the bucket. The long floor and open throat design of the Performance Series Buckets along with the aggressive rack angles of the optimized K Series linkage will demonstrate fill factors greater than 100% ISO rated. Refer to the Fill Factors table for expected fill factor per material density and Bucket Selection Table for bucket sizing.

Aggregate Handler Fill Factors

Materials	Density	Fill %	
Dry sand	~ 1450 kg/m ³	~ 2,407 lb/yd ³	~ 115%
Aggregates	~ 1600 kg/m ³	~ 2,696 lb/yd ³	~ 105%
Damp sand	~ 1700 kg/m ³	~ 2,822 lb/yd ³	~ 115%

Aggregate Handler Ground Engagement Options

	Long Teeth and Segments		Short Teeth and Segments	
Dig depth	+12 mm	+0.5 in	+5 mm	+0.2 in
Length: overall	+146 mm	+5.7 in	+121 mm	+4.8 in
Dump clearance	-103 mm	-4.1 in	-82 mm	-3.2 in
Reach	+104 mm	+4.1 in	+89 mm	+3.5 in
Tipping load – straight	-151 kg	-332 lb	-145 kg	-319 lb
Tipping load – full turn	-148 kg	-326 lb	-142 kg	-312 lb
Breakout force	-121 kg	-266 lb	-115 kg	-253 lb
Operating weight	+120 kg	+264 lb	+116 kg	+255 lb

Operating Specifications with Pallet Forks

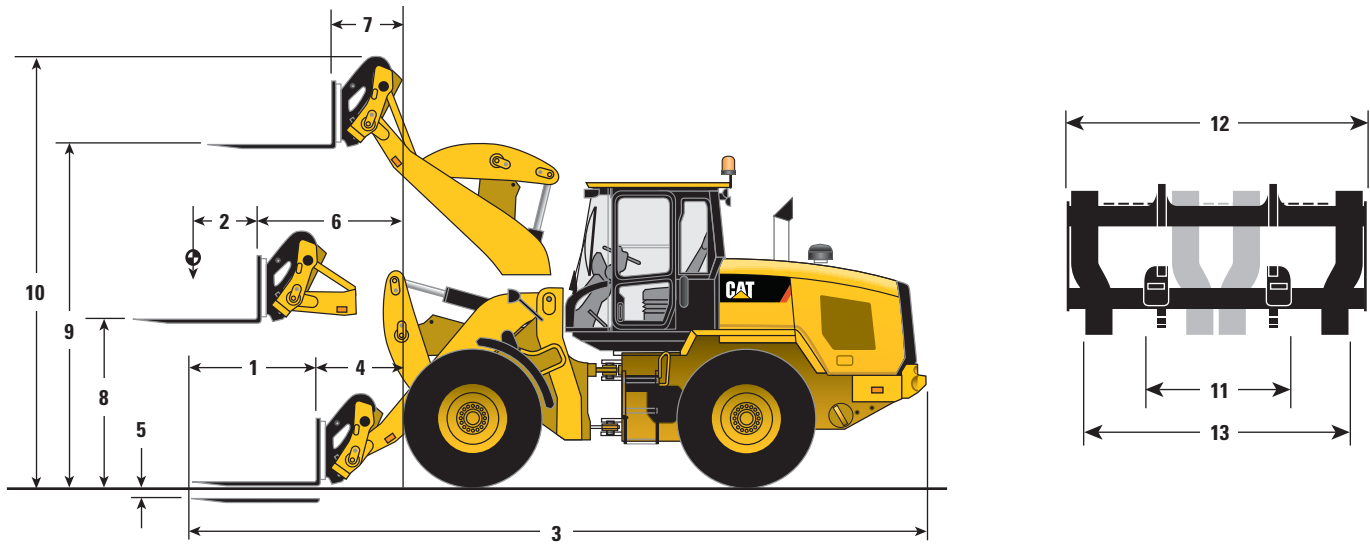

Pallet Fork – Fusion

	924K		930K		938K	
1 Fork tine length	1220 mm	4'0"	1220 mm	4'0"	1220 mm	4'0"
2 Load center	610 mm	2'0"	610 mm	2'0"	610 mm	2'0"
3 Length: overall	7840 mm	25'8"	7882 mm	25'10"	7942 mm	26'0"
4 Reach: ground	891 mm	2'11"	926 mm	3'0"	961 mm	3'1"
5 Dig depth	47 mm	1.9"	47 mm	1.9"	44 mm	1.7"
6 Reach: level arm	1522 mm	4'11"	1569 mm	5'1"	1617 mm	5'3"
7 Reach: full lift	724 mm	2'4"	767 mm	2'6"	814 mm	2'8"
8 Clearance: level arm	1761 mm	5'9"	1792 mm	5'10"	1830 mm	6'0"
9 Clearance: full lift	3639 mm	11'11"	3693 mm	12'1"	3758 mm	12'3"
10 Height: overall	4621 mm	15'1"	4676 mm	15'4"	4740 mm	15'6"
Tipping load – straight, ISO 14397-1*	6615 kg	14,584 lb	7351 kg	16,206 lb	8571 kg	18,896 lb
Tipping load – full turn, ISO 14397-1*	5670 kg	12,500 lb	6287 kg	13,860 lb	7311 kg	16,118 lb
Operating weight	12 070 kg	26,610 lb	13 166 kg	29,026 lb	15 056 kg	33,193 lb
Rated load % of full turn tip:						
50% of tip: SAE J1197**	2835 kg	6,250 lb	3144 kg	6,931 lb	3655 kg	8,058 lb
60% of tip: rough terrain EN474-3**	3402 kg	7,500 lb	3772 kg	8,316 lb	4387 kg	9,672 lb
80% of tip: firm and level EN474-3**	4536 kg	10,000 lb	5030 kg	11,089 lb	5849 kg	12,895 lb
11 Minimum fork spacing	300 mm	11"	300 mm	11"	300 mm	11"
12 Carriage width	1566 mm	5'1"	1566 mm	5'1"	1566 mm	5'1"
13 Maximum fork spacing	1550 mm	5'1"	1550 mm	5'1"	1550 mm	5'1"

*Full compliance to ISO 14397-1 (2007) Sections 1 through 6, which requires 2% verification between calculation and testing.

**Full compliance to EN474-3 and SAE J1197.

Dimensions listed are for a machine configured with Fusion work tool, heavy counterweights, 80 kg (176 lb) operator, and Michelin 20.5 R25 (L-3) XHA2 tires.

Operating Specifications

Operating Specifications with Construction Forks

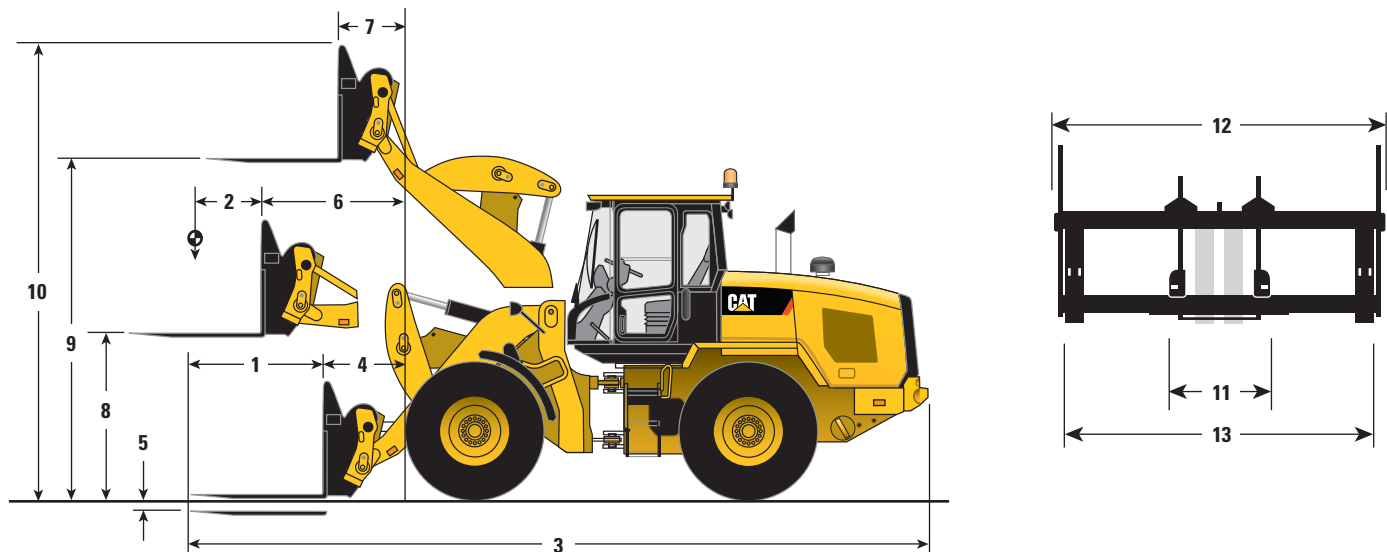

Construction Fork – Fusion

	924K		930K		938K	
1 Fork tine length	1524 mm	5'0"	1524 mm	5'0"	1524 mm	5'0"
2 Load center	762 mm	2'6"	762 mm	2'6"	762 mm	2'6"
3 Length: overall	8263 mm	27'1"	8305 mm	27'2"	8366 mm	27'5"
4 Reach: ground	1009 mm	3'3"	1045 mm	3'5"	1081 mm	3'6"
5 Dig depth	120 mm	4.7"	-120 mm	-4.7"	-119 mm	-4.7"
6 Reach: level arm	1580 mm	5'2"	1627 mm	5'4"	1675 mm	5'5"
7 Reach: full lift	782 mm	2'6"	825 mm	2'8"	872 mm	2'10"
8 Clearance: level arm	1698 mm	5'6"	1729 mm	5'8"	1766 mm	5'9"
9 Clearance: full lift	3575 mm	11'8"	3630 mm	11'10"	3693 mm	12'1"
10 Height: overall	4880 mm	16'0"	4935 mm	16'2"	0 mm	0"
Tipping load – straight, ISO 14397-1*	5911 kg	13,032 lb	6604 kg	14,559 lb	7749 kg	17,084 lb
Tipping load – full turn, ISO 14397-1*	5036 kg	11,102 lb	5617 kg	12,383 lb	6577 kg	14,500 lb
Operating weight	12 404 kg	27,346 lb	13 501 kg	29,765 lb	15 390 kg	33,929 lb
Rated load % of full turn tip:						
50% of tip: SAE J1197**	2518 kg	5,551 lb	2808 kg	6,191 lb	3288 kg	7,249 lb
60% of tip: rough terrain EN474-3**	3022 kg	6,662 lb	3370 kg	7,430 lb	3946 kg	8,699 lb
80% of tip: firm and level EN474-3**	4029 kg	8,882 lb	4494 kg	9,908 lb	5261 kg	11,599 lb
11 Minimum fork spacing	300 mm	11"	300 mm	11"	300 mm	11"
12 Carriage width	2498 mm	8'2"	2498 mm	8'2"	2498 mm	8'2"
13 Maximum fork spacing	2375 mm	7'9"	2375 mm	7'9"	2375 mm	7'9"

*Full compliance to ISO 14397-1 (2007) Sections 1 through 6, which requires 2% verification between calculation and testing.

**Full compliance to EN474-3 and SAE J1197.

Dimensions listed are for a machine configured with Fusion work tool, heavy counterweights, 80 kg (176 lb) operator, and Michelin 20.5 R25 (L-3) XHA2 tires.

Operating Specifications with Material Handling Arm

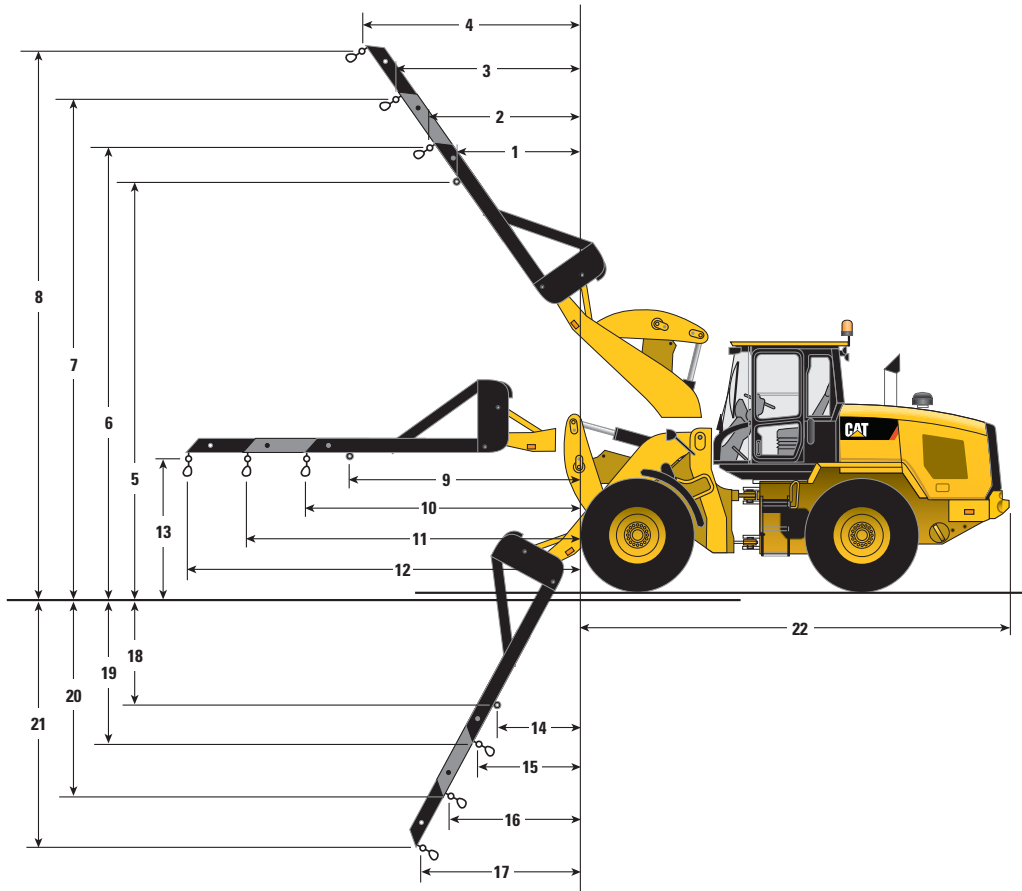

Material Handling Arm – Fusion

	924K		930K		938K		924K		930K		938K		
1	2279 mm	7'5"	2113 mm	6'11"	2144 mm	7'0"	12	5280 mm	17'3"	5327 mm	17'5"	5376 mm	17'7"
2	2551 mm	8'4"	2333 mm	7'7"	2362 mm	7'8"	13	1823 mm	5'11"	1854 mm	6'0"	1890 mm	6'2"
3	3223 mm	10'6"	2919 mm	9'6"	2943 mm	9'7"	14	278 mm	10"	863 mm	2'9"	906 mm	2'11"
4	3896 mm	12'9"	3505 mm	11'6"	3525 mm	11'6"	15	373 mm	1'2"	1045 mm	3'5"	1089 mm	3'6"
5	4867 mm	15'11"	5257 mm	17'2"	5343 mm	17'6"	16	411 mm	1'4"	1276 mm	4'2"	1324 mm	4'4"
6	5134 mm	16'10"	5568 mm	18'3"	5655 mm	18'6"	17	448 mm	1'5"	1507 mm	4'11"	1559 mm	5'1"
7	5567 mm	18'3"	6112 mm	20'0"	6204 mm	20'4"	18	2013 mm	6'7"	1975 mm	6'5"	1983 mm	6'6"
8	6000 mm	19'8"	6657 mm	21'10"	6754 mm	22'1"	19	2381 mm	7'9"	2310 mm	7'6"	2316 mm	7'7"
9	3307 mm	10'10"	3354 mm	11'0"	3403 mm	11'1"	20	3180 mm	10'5"	3076 mm	10'1"	3081 mm	10'1"
10	3680 mm	12'0"	3727 mm	12'2"	3775 mm	12'4"	21	3979 mm	13'0"	3842 mm	12'7"	3846 mm	12'7"
11	4480 mm	14'8"	4527 mm	14'10"	4575 mm	15'0"	22	5730 mm	18'9"	5737 mm	18'9"	5762 mm	18'10"
Operating weight			11 926 kg	26,292 lb	13 361 kg	29,456 lb	15 244 kg			33,606 lb			
Rated load (50% of full turn tip, SAE J1197*)													
Fixed tab (9)			2023 kg	4,460 lb	2329 kg	5,134 lb	2705 kg			5,963 lb			
Minimum extension (10)			1853 kg	4,085 lb	2135 kg	4,706 lb	2482 kg			5,472 lb			
Middle extension (11)			1569 kg	3,459 lb	1811 kg	3,992 lb	2109 kg			4,649 lb			
Maximum extension (12)			1361 kg	2,999 lb	1572 kg	3,466 lb	1833 kg			4,041 lb			

*Full compliance to EN474-3 and SAE J1197.

Supplemental Specifications

Optional Equipment

	924K				930K				938K			
	Operating weight		Tipping load – full turn with 1.9 m ³ (2.5 yd ³) Fusion bucket		Operating weight		Tipping load – full turn with 2.1 m ³ (2.75 yd ³) Fusion bucket		Operating weight		Tipping load – full turn with 2.5 m ³ (3.25 yd ³) Fusion bucket	
	kg	lb	kg	lb	kg	lb	kg	lb	kg	lb	kg	lb
Without heavy counterweight	-320	-705	-521	-1,149	-320	-705	-509	-1,122	-320	-705	-502	-1,107
Without cab (semi-cab option)	-100	-220	-116	-256	-100	-220	-112	-247	-100	-220	-113	-249
With guard, driveshaft	+44	+97	+12	+26	+44	+97	+12	+26	+45	+99	+12	+26
With ride control	+49	+107	+27	+60	+49	+107	+27	+60	+49	+108	+27	+60
With roading fenders	+18	+40	+25	+55	+18	+40	+24	+53	+18	+40	+24	+53
With guards, front lights	+11	+24	+2	+4	+11	+24	+2	+4	+11	+24	+2	+4
With guard, hitch	+54	+119	+37	+82	+54	+119	+36	+79	+54	+119	+36	+79
With guard, front window	+34	+75	+19	+42	+34	+75	+19	+42	+34	+75	+19	+42
With guards, steering cylinders	+14	+31	+10	+22	+14	+31	+10	+22	+14	+31	+10	+22
With guard, power train lower	+77	+170	+72	+159	+77	+170	+70	+154	+70	+154	+63	+139
With secondary steering	+69	+152	+76	+168	+69	+152	+74	+163	+69	+152	+74	+163
With guard, crankcase	+19	+42	+25	+55	+19	+42	+25	+55	+11	+24	+14	+31
With guards, power train side	+11	+24	+9	+20	+11	+24	+9	+20	+11	+24	+9	+20
With tool box	+44	+97	+26	+57	+44	+97	+25	+55	+44	+97	+25	+55
With guard, rear waste gate	N/A	N/A	N/A	N/A	+276	+608	+495	+1,091	+276	+608	+488	+1,076
With cold start package	+54	+119	+77	+170	+54	+119	+75	+165	+54	+119	+75	+165
With logger counterweight	N/A	N/A	N/A	N/A	+400	+882	+564	+1,243	+400	+882	+557	+1,228

Standard Equipment

Standard equipment may vary. Consult your Cat dealer for details.

POWER TRAIN

- Axle seal guards
- Auto idle shut down feature
- Brake/decelerator pedal
- Cat C7.1 ACERT engine
 - Tier 3/Stage IIIA compliant
 - Turbocharged and aftercooled
 - Filtered crankcase breather
- Coolant protection to -34°C (-29°F)
- Differential front open
- Differential rear open
- Dry type air cleaner
- Enclosed wet disc full hydraulic brakes
- Fuel priming pump, automatic
- Fuel water separator
- Hydraulically driven demand cooling fan
- Hydrostatic transmission with electronic speed range control
 - 4 speed ranges
 - Rimpull control
 - Creeper control
- Lubed for life driveshafts
- Parking brake, electric
- Single plane cooling system with remote coolant reservoir
- S·O·SSM port, engine, coolant and transmission oil
- Thermal starting aid (glow plugs)
- Throttle lock
- Transmission directional control on implement joystick
- Transmission sight gauge
- Transmission oil cooler (938K only)

HYDRAULICS

- Heavy duty hydraulic cooler
- Hydraulic diagnostic connectors and S·O·S ports
- Hydraulic sight gauge, visible
- Load sensing hydraulics and steering
- Seat-mounted hydraulic controls with F/N/R

ELECTRICAL

- Alternator, 115-amp, heavy duty
- 12V power supply in cab (2)
- Batteries, 1,000 CCA (2)
- 24 volt system
- Back-up alarm
- Battery disconnect switch
- Beacon ready
- Diagnostic connector
- Directional signals front and rear
- Emergency shutdown switch
- Halogen work lights front and rear
- Heavy duty gear reduction starter
- LED rear stop tail turn lights
- Remote jump start post
- Resettable main and critical function breakers
- Roading lights front and rear

OPERATOR ENVIRONMENT

- 75 mm (3 in) retractable seatbelt
- Automatic temperature control
- Cab, enclosed ROPS/FOPS pressurized and sound suppressed
- Cup holder
- External mirrors
- Ground level cab door release
- Gauges
 - Digital direction indicator
 - Digital hour meter and odometer
 - Digital speedometer
 - Engine coolant temperature gauge
 - Fuel level indicator
 - Hydraulic oil temperature gauge
 - Tachometer
- Hydraulic control lockout
- Interior cab lighting, door and dome
- Interior rearview mirrors (2)
- Lunch box storage
- Operator warning system indicators
- Radio ready speakers
- Rear window defrost, electric
- Removable floormat
- Seat-mounted electronic implement controls, adjustable
- Sliding glass on the side windows
- Steering column mounted multi function control – lights, wipers, turn signal
- Suspension seat, fabric
- Tilt and telescopic steering wheel
- Tinted front glass
- Wet arm wiper/washer, 2-speed and intermittent, front

OTHER STANDARD EQUIPMENT

- Automatic bucket/fork positioner, adjustable in-cab
- Automatic lift and bucket kickouts, adjustable in-cab
- Fenders
- Large-access enclosure doors with adjustable close/open force
- Parallel lift loader linkage with sealed pins
- Recovery hitch with pin
- Remote mounted lubrication points
- Toolbox, lockable
- Vandalism protection – lockable compartments

NOTE: Not all features are available in all regions. See your Cat dealer for more information.

924K, 930K, 938K Optional Equipment

Optional Equipment

Optional equipment may vary. Consult your Cat dealer for details.

- Antifreeze/coolant, extended-life, protects to -50°C (-58°F)
- Axles, differential, limited slip, rear
- Axles, differential lock, front
- Beacon light, rotating or strobe
- Camera, rearview (standard in Europe)
- Cold start package:
 - Ether starting aid
 - Block heater
 - Additional batteries (2)
- Counterweight, heavy
- Counterweight, logger
- Coupler, Fusion
- Coupler, ISO 23727
- Coupler, jumper lines, third function
- Debris package
- Debris package – cleaning arrangement
- Fenders, roading
- Guards
 - Power train, lower
 - Power train, side
 - Crankcase
 - Driveshaft
 - Windshield
 - Steer cylinder
 - Hitch
 - Tilt cylinder
- Hydraulic control auxiliary, third and fourth function
- Jumper lines, third function
- Linkage, high lift
- Lights, auxiliary, halogen or HID
- Machine Security System
- Product Link
- Radio packages:
 - Radio ready with Bluetooth interface, microphone and auxiliary inputs for MP3 players
 - Radio, AM/FM with CD player
 - Radio, AM/FM with CD player deluxe, Bluetooth interface, microphone and auxiliary inputs for MP3 players
- Remote axle breathers
- Ride Control System
- Seats:
 - Deluxe seat – fully adjustable fabric air suspension seat with high seat backrest
- Semi-cab
- Steering:
 - Dual mode
 - Secondary
- Tires:
 - Bias ply, 20.5-25
 - Radial, 17.5 R25, 20.5 R25, 550/65 R25, 650/65 R25
 - Flexport
 - Skidder/Agriculture
- Toolbox, additional
- Work tools

NOTE: Not all features are available in all regions. See your Cat dealer for more information.

For more complete information on Cat products, dealer services, and industry solutions, visit us on the web at www.cat.com

AEHQ7034 (07-2013)

© 2013 Caterpillar Inc.
All rights reserved

Materials and specifications are subject to change without notice. Featured machines in photos may include additional equipment. See your Cat dealer for available options.

CAT, CATERPILLAR, SAFETY.CAT.COM, their respective logos, "Caterpillar Yellow" and the "Power Edge" trade dress, as well as corporate and product identity used herein, are trademarks of Caterpillar and may not be used without permission.

