

906H2, 907H2, 908H2

Compact Wheel Loaders



Engine	906H2	907H2	908H2
Engine Model	Cat® C3.3B DIT*	Cat C3.3B DIT*	Cat C3.3B DIT*
Rated Net Power @ 2,500 rpm			
SAE J1349	51 kW (68 hp)	51 kW (68 hp)	51 kW (68 hp)
Maximum Gross Power			
ISO 14396	55 kW (73 hp)	55 kW (73 hp)	55 kW (73 hp)
SAE J1995	55 kW (74 hp)	55 kW (74 hp)	55 kW (74 hp)
Maximum Net Power			
ISO 9249	52 kW (69 hp)	52 kW (69 hp)	52 kW (69 hp)
SAE J1349	51 kW (68 hp)	51 kW (68 hp)	51 kW (68 hp)

*The Cat C3.3B DIT engine meets Tier 4 Interim emission standards.

906H2, 907H2, 908H2 Features

High Performance

With its high full turn tipping loads and breakout forces, the H2 Series delivers a powerful solution for all customer applications.

Ease of Operation

Operating the H2 Series Compact Wheel Loader couldn't be easier. Simple controls and the ergonomically designed, low effort joystick reduce fatigue and increase comfort.

Power Train

The standard hydrostatic driveline is a 20 km/h (12.4 mph) transmission. Heavy duty axles and 100% diff-lock are standard with ride control and 35 km/h (21.7 mph) high speeder available as options.

High Flow Work Tools

The standard skid steer loader style coupler combined with standard flow or optional high flow hydraulics allow the Cat Compact Wheel Loaders to use a large range Cat Work Tools including hydromechanical work tools



Contents

Operator Station.....	4
Power Train.....	5
Loader Linkage.....	5
Work Tools.....	6
Serviceability & Customer Support.....	8
Specifications.....	10
Standard Equipment.....	14
Optional Equipment.....	15



The Cat 906H2, 907H2 and 908H2 Compact Wheel Loaders deliver performance with versatility. Spacious, comfortable cab with the joystick control allows you to get more done. Loader design delivers strength and durability with parallel lifting. The work tool quick coupler allows the use of Cat Skid Steer, Multi Terrain and Compact Track Loader hydromechanical work tools on the Cat Compact Wheel Loader for greater machine versatility. Expand your business with the Cat H2 Series Compact Wheel Loaders.

Operator Station

Superior comfort keeps you productive, all day long.



Cab Comfort

Spacious, comfortable cab helps you stay productive throughout the work day. Low effort joystick and steering, intuitively laid out controls, two arm rests and an adjustable wrist rest are some of the many features built into the H2 Series Compact Wheel Loader for maximum operator comfort. A variety of options makes it easy to customize the cab to your requirements. Select the operator station that meets your needs – Canopy, Comfort Cab or Deluxe Cab. Optional air conditioning system is standard in the Deluxe Cab for additional operator comfort. All cabs are fully pre-wired, making it easy to install future options.

Low Effort Controls

Pilot hydraulics keep operator fatigue low. The single multi functional joystick contains FNR (Forward/Neutral/Reverse), travel speed, third function auxiliary hydraulics (for hydromechanical work tools), differential lock and continuous flow controls.

Excellent Visibility

Work site visibility has been maximized with two fully glazed doors, front low-level glazing, excellent rear visibility and a clear view to the work tool through the loader arms.

Low Cab Height on the 906H2

The 906H2 features a low cab height of 2465 mm (8 ft 1 in) to provide access to more areas on the job site.



Power Train

Cat Hystat™ power train delivers aggressive performance.

Cat 3.3B DIT U.S. EPA Tier 4 Interim Compliant Engine

Engine service area features eco-friendly drains, easily accessible filters, ground level service points, and separate coolers for cleaning. The electric fuel pump self-primers dry, fresh filters to make servicing fast and contamination free.

Chassis and Heavy Duty Axles

With 18 degrees of motion, the oscillating chassis assures four wheel ground contact. Heavy duty axles with outboard planetary reduction gears are more durable. Standard differential locks in both axles can be engaged on the move.

Two Speed Options

The hydrostatic drive line offers two speeds in “Low” range: 1st Gear – 7 km/h (4.3 mph) and 2nd Gear – 20 km/h (12.4 mph). The optional speeder transmission provides up to 35 km/h (21.7 mph) in “High” range. Both versions feature smooth inching with the brake pedal as standard.

Additionally, an optional transmission control upgrade offers creeper control, rimpull control and hand throttle. The combination of creeper and hand throttle is used for powering hydromechanical work tools such as snowblowers or cold planers. The rimpull control reduces the amount of tire slippage in soft or loose underfoot conditions, adjusted between 60% and 100% tractive force.

Ride Control

The optional Ride Control improves operator comfort, material retention, machine controllability, and higher productivity. Three modes are available – auto, on and off. This feature is highly recommended if the machine is equipped with the 35 km/h (21.7 mph) speeder option.



Loader

Linkage

Optimal digging forces with parallel lift.

Parallel Lift Z-bar Design

The high performance Z-bar loader design is built for strength and excellent work tool visibility. The standard skid steer loader style quick coupler ensures maximum versatility. The Z-bar linkage gives the operator a clear view to the work tool and excellent dump clearance while maintaining good cycle times and parallel lift.



Work Tools

Do more jobs with one machine with Cat Work Tools.



The Right Tool for the Job

Increase the versatility of the machine with the wide range of Cat buckets, forks and hydraulically powered work tools. Work tools can be changed quickly and easily with the machine's quick coupler system. Available work tools include:

- Buckets
- Forks
- Augers
- Brooms
- Cold Planers
- Landscape Rakes
- Landscape Tillers
- Material Handling Arm
- Power Box Rakes
- Snow Removers
- Stump Grinders
- Trenchers
- Vibratory Compactors

For a complete list of available work tools, please consult your Cat dealer.

Additional Options to Increase Productivity

Caterpillar offers the following options to further increase your productivity:

- Return to dig work tool positioner automatically returns the bucket to level position after dumping.
- Work tool wiring harness for fourth hydraulic function such as broom angling.
- Transmission control upgrade includes speed control, rimpull control and hand throttle control. Speed control (creeper) provides variable control of ground speed while maintaining optimal hydromechanical work tool speed, such as using snow blowers, cold planers or wheel saws. Rimpull control optimizes bucket loading and reduces wheel spin under soft or loose underfoot conditions. Hand throttle control provides infinitely variable means of fixing engine speed, ideal for steady operation of hydromechanical work tools.
- High flow auxiliary hydraulics at 125 L/min (33 gal/min) for high flow work tools.



Skid Steer Loader Style Coupler

The universal skid steer loader style coupler allows the use of many Cat Skid Steer, Multi Terrain and Compact Track Loader hydromechanical work tools. Auxiliary lines and connectors are standard equipment. Using either the standard flow or optional high flow hydraulics, this coupler system allows the H2 Series Compact Wheel Loaders to easily integrate into a Cat Skid Steer, Multi Terrain or Compact Track Loader fleet.

Convenient Service Features

High opening, easy to lift engine hood and side service doors provide easy access to all major components and service points from ground level.

- Valves and pressure taps are conveniently located in the engine bay for S-O-SSM analysis of engine and hydraulic system cleanliness and service requirements, prolonging machine life.
- Two stage air cleaner with a built-in centrifugal precleaner, secondary element and a visual restriction indicator improves service life.
- Auxiliary fuses, diagnostic sockets, master disconnect switch and other regular service points are all located together for ease of servicing.
- Spin-on engine and hydraulic oil filters and fuel filter with water separator are located for easier servicing.
- Heavy-duty wiring increases electrical durability and is multicolored to ease diagnosis and fault finding. Water resistant sealed connectors prevent dust and moisture from interfering with the electronics.
- Hydraulic oil cooler swings out using a handle in the engine bay for easy access to the radiator and cooler for cleaning.
- Electronic Technician allows advanced diagnostics and fault code investigation using Cat service tools.
- Eco drain line and quick coupling for coolant is located on-board for mess free flushing.

Unmatched support makes the difference.

Superior Dealer Service

Your Cat dealer is ready to assist you with your purchase decision and everything after.

- Make comparisons of machines, with estimates of component life, preventative maintenance and operational costs.
- Financing packages are flexible to meet your needs.
- Your Cat dealer can evaluate the cost to repair, rebuild or replace your machine, so you can make the right choice for your business.
- For more information on Cat products, dealer services and industry solutions, visit us at www.cat.com.



Serviceability & Customer Support

Easy access and minimal maintenance requirements reduce downtime.



906H2, 907H2, 908H2 Compact Wheel Loaders Specifications

Engine

Model	Cat C3.3B DIT*	
Gross Power @ 2,500 rpm – 906H2/907H2/908H2 – SAE J1995	55 kW	74 hp
Net Power @ 2,500 rpm – 906H2/907H2/908H2 – SAE J1349	51 kW	68 hp
Bore	94 mm	3.7 in
Stroke	120 mm	4.7 in
Displacement	3.3 L	203 in ³

- The Cat C3.3B DIT engine meets U.S. EPA Tier 4 Interim emission standards.

Weights

Operating Weight – 906H2	5630 kg	12,412 lb
Operating Weight – 907H2	5810 kg	12,809 lb
Operating Weight – 908H2	6465 kg	14,253 lb

Transmission

Travel Speed 1	7 km/h	4.3 mph
Travel Speed 2	20 km/h	12.4 mph
High Speed	35 km/h	21.7 mph

Cab

ROPS	SAE J1040 MAY94, ISO 3471-1994
FOPS	SAE J/ISO 3449 APR98 Level II, ISO 3449 1992 Level II

Hydraulic System

Main Relief	235 bar	3,400 psi
3rd Auxiliary Flow, Standard Flow	83 L/min	22 gal/min
3rd Auxiliary Flow, High Flow	125 L/min	33 gal/min
Hydraulic Cycle Time – Lift	5 Seconds	
Hydraulic Cycle Time – Dump	2 Seconds	
Hydraulic Cycle Time – Lower, Float	4 Seconds	
Hydraulic Cycle Time – Rackback	2.5 Seconds	

Service Refill Capacities

Cooling System	24 L	6.3 gal
Fuel Tank – 906H2	52 L	13.7 gal
Fuel Tank – 907H2/908H2	78 L	20.6 gal
Hydraulic System	95 L	25 gal
Engine Oil	10 L	2.6 gal

Buckets

Bucket Capacities – 906H2	0.75-1.2 m ³	0.98-1.6 yd ³
Bucket Capacities – 907H2	0.75-1.2 m ³	0.98-1.6 yd ³
Bucket Capacities – 908H2	0.9-1.5 m ³	1.2-2.0 yd ³

Operating Specifications

	906H2		907H2		908H2	
Tire Size	405/70 R18		405/70 R18		405/70 R20	
Rated Bucket Capacity	0.9 m ³	1.18 yd ³	1.0 m ³	1.3 yd ³	1.1 m ³	1.4 yd ³
Hydraulic Lift Capacity	3263 kg	7,194 lb	3263 kg	7,194 lb	3569 kg	7,868 lb
Breakout Force	42 kN	9,442 lb	42 kN	9,442 lb	47 kN	10,566 lb
Rated Operating Load @ Full Turn, Bucket	1580 kg	3,483 lb	1585 kg	3,494 lb	1705 kg	3,759 lb
Straight Tipping Load, Bucket	3985 kg	8,785 lb	4320 kg	9,524 lb	4775 kg	10,527 lb
Full Turn Static Tipping Load, Bucket	3160 kg	6,967 lb	3170 kg	6,989 lb	3410 kg	7,518 lb
Rackback, Transport Position	52 Degrees		52 Degrees		52 Degrees	
Rated Operating Load @ Full Turn, Forks (EN 474-3:2006, Firm and Level Ground, 500 mm [20 in] Load Center) (80% of FTSTL)	2065 kg	4,553 lb	2120 kg	4,674 lb	2355 kg	5,192 lb
Rated Operating Load @ Full Turn, Forks (EN 474-3:2006, Rough Terrain, 500 mm [20 in] Load Center) (60% of FTSTL)	1549 kg	3,415 lb	1590 kg	3,505 lb	1766 kg	3,893 lb
Rated Operating Load @ Full Turn, Forks (EN 474-3:2006, Firm and Level Ground, 1.25 Stability and 500 mm [20 in] Load Center)	2065 kg	4,553 lb	2120 kg	4,674 lb	2355 kg	5,192 lb
Rated Operating Load @ Full Turn, Forks (SAE J1197, Load Center @ Tine Mid-Point, 1120 mm [44 in] Tines) (50% FTSTL)	1203 kg	2,652 lb	1234 kg	2,721 lb	1381 kg	3,045 lb
Rated Operating Load @ Full Turn, Forks (SAE J1197, Load Center @ Tine Mid-Point, 1220 mm [48 in] Tines) (50% FTSTL)	1154 kg	2,544 lb	1183 kg	2,608 lb	1324 kg	2,919 lb
Rated Operating Load Straight Back, Forks (SAE J1197, Load Center @ Tine Mid-Point, 1120 mm [44 in] Tines) (50% FTSTL)	1577 kg	3,476 lb	1607 kg	3,543 lb	1772 kg	3,907 lb
Rated Operating Load Straight Back, Forks (SAE J1197, Load Center @ Tine Mid-Point, 1220 mm [48 in] Tines) (50% FTSTL)	1544 kg	3,404 lb	1574 kg	3,470 lb	1733 kg	3,822 lb
Rated Operating Load @ Full Turn, Forks (EN 474-3:2006, Firm and Level Ground, 500 mm [20 in] Load Center) (Transport 100 mm [4 in] Above Ground)	2720 kg	5,997 lb	2785 kg	6,140 lb	2990 kg	6,592 lb

- Specifications shown are for 906H2, 907H2, and 908H2 with full fuel tank, 75 kg (165 lb) operator, ROPS/FOPS cab, skid steer loader style coupler and general purpose bucket.

906H2, 907H2, 908H2 Compact Wheel Loaders Specifications

Dimensions

All dimensions are approximate. Dimensions shown are based on the machine equipped with general purpose bucket and standard 405/70 SPT9 tires. Refer to Operating Specifications.

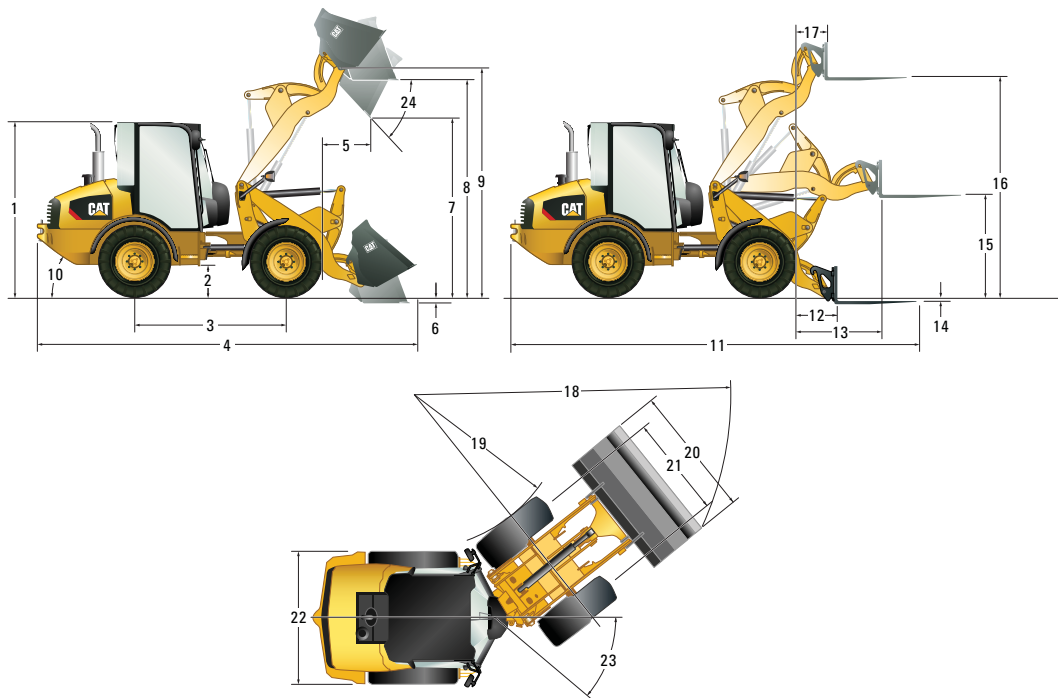

	906H2		907H2		908H2	
1 Cab Height	2465 mm	8 ft 1 in	2585 mm	8 ft 6 in	2650 mm	8 ft 8 in
2 Ground Clearance	300 mm	11.8 in	300 mm	11.8 in	340 mm	13 in
3 Wheelbase	2170 mm	7 ft 1 in	2170 mm	7 ft 1 in	2170 mm	7 ft 1 in
4 Overall Length with Bucket	5585 mm	18 ft 4 in	5585 mm	18 ft 4 in	5760 mm	18 ft 11 in
5 Reach at Maximum Dump Height	810 mm	2 ft 8 in	810 mm	2 ft 8 in	855 mm	2 ft 10 in
6 Dig Depth	90 mm	3.5 in	90 mm	3.5 in	95 mm	3.7 in
7 Maximum Dump Height	2395 mm	7 ft 10 in	2395 mm	7 ft 10 in	2540 mm	8 ft 4 in
8 Load Over Height	3035 mm	9 ft 11 in	3035 mm	9 ft 11 in	3215 mm	10 ft 7 in
9 Hinge Pin at Maximum Height	3230 mm	10 ft 7 in	3230 mm	10 ft 7 in	3410 mm	11 ft 2 in
10 Departure Angle (Degrees)	34°		34°		34°	
11 Overall Length with Forks	5945 mm	19 ft 6 in	5945 mm	19 ft 6 in	6150 mm	20 ft 2 in
12 Reach at Ground Level	750 mm	2 ft 6 in	750 mm	2 ft 6 in	925 mm	3 ft
13 Maximum Reach	1265 mm	4 ft 2 in	1265 mm	4 ft 2 in	1445 mm	4 ft 9 in
14 Fork Depth (Above Ground)	(45 mm)	(1.8 in)	(45 mm)	(1.8 in)	30 mm	1.2 in
15 Fork Height at Maximum Reach	1490 mm	4 ft 11 in	1490 mm	4 ft 11 in	1525 mm	5 ft
16 Maximum Fork Height	3160 mm	10 ft 4 in	3160 mm	10 ft 4 in	3300 mm	10 ft 10 in
17 Fork Reach at Maximum Height	505 mm	1 ft 8 in	505 mm	1 ft 8 in	595 mm	1 ft 11 in
18 Turning Radius Over Bucket	4445 mm	14 ft 7 in	4515 mm	14 ft 10 in	4560 mm	15 ft
19 Turning Radius Inside Tire	2240 mm	7 ft 4 in	2240 mm	7 ft 4 in	2080 mm	6 ft 10 in
20 Width Over Bucket	1880 mm	6 ft 2 in	2035 mm	6 ft 8 in	2060 mm	6 ft 9 in
21 Tire Gauge	1420 mm	4 ft 8 in	1420 mm	4 ft 8 in	1570 mm	5 ft 2 in
22 Machine Width	1840 mm	6 ft	1840 mm	6 ft	1985 mm	6 ft 6 in
23 Articulation Angle (Degrees)	39°		39°		39°	
24 Dump Angle at Maximum Height (Degrees)	45°		45°		45°	

Maximum Material Densities

Based on ISO 7546:1983 and rated operating loads at full turn.

906H2

Bucket Type	General Purpose		Multi Purpose		Light Material	
Rated Capacity	0.9 m ³	1.18 yd ³	0.75 m ³	0.98 yd ³	1.2 m ³	1.6 yd ³
Dump Height	2395 mm	94 in	2470 mm	97 in	2285 mm	90 in
Maximum Material Density	1755 kg/m ³	2,958 lb/yd ³	2131 kg/m ³	3,592 lb/yd ³	1208 kg/m ³	2,036 lb/yd ³
Bucket Width	1880 mm	74 in	1880 mm	74 in	2080 mm	82 in

907H2

Bucket Type	General Purpose		Multi Purpose		Light Material	
Rated Capacity	1.0 m ³	1.3 yd ³	0.75 m ³	0.98 yd ³	1.2 m ³	1.6 yd ³
Dump Height	2395 mm	94 in	2470 mm	97 in	2285 mm	90 in
Maximum Material Density	1584 kg/m ³	2,670 lb/yd ³	2149 kg/m ³	3,622 lb/yd ³	1218 kg/m ³	2,053 lb/yd ³
Bucket Width	2035 mm	80 in	1880 mm	74 in	2080 mm	82 in

908H2

Bucket Type	General Purpose		Multi Purpose		Light Material	
Rated Capacity	1.1 m ³	1.4 yd ³	0.9 m ³	1.18 yd ³	1.5 m ³	2.0 yd ³
Dump Height	2540 mm	100 in	2630 mm	104 in	2345 mm	92 in
Maximum Material Density	1549 kg/m ³	2,611 lb/yd ³	1929 kg/m ³	3,251 lb/yd ³	1034 kg/m ³	1,743 lb/yd ³
Bucket Width	2060 mm	81 in	2060 mm	81 in	2080 mm	82 in

Operator Environment Features

	Deluxe Cab	Comfort Cab	Canopy
Operator Environment Features			
Two Access Doors	•	•	
Fixed Steering Column			•
Adjustable Steering Column	•	•	
Vinyl Suspension Seat			•
Cloth Suspension Seat, Arm Rest		•	
Cloth Electric Air Suspension Seat, Arm/Head Rest, Lumbar Support, Heated Back Seat	•		
Left Window – Sliding	•	•	
Right Window – Sliding	•		
Heated Rear Window	•	•	
Coat Hook	•	•	•
Cabin Light	•	•	
Sun Visor	•	•	•
Radio-ready Kit (Wiring, Speaker, Antenna and Grilles)	•	•	
External Mirrors (2) – Knock Back	•	•	•
Heater	•	•	
Lockable Storage Box	•	•	•
Adjustable Internal Mirror	•	•	•
Air Conditioning	•		
Optional Cab Features			
Rear Blind	•	•	
Cat Radio/CD/MP3/WMA Player	•	•	

906H2, 907H2, 908H2 Standard Equipment

Standard Equipment

Standard equipment may vary. Consult your Cat dealer for details.

TRANSMISSION/HYDRAULICS

- Transmission, 20 km/h (12.4 mph); standard axles with hydraulically actuated dry disc brakes
- Transmission inching function
- Hydrostatic drive
- 100% Differential Lock on both axles, selectable on the move
- Frame mounted heavy duty axles with outboard planetary reduction
- Maintenance free, sealed for life, prop shaft and universal joints

LOADER

- Skid steer loader style hydraulic quick coupler
- Proportional auxiliary hydraulic circuit
- Loader arm float function
- Connect under pressure hydraulic quick connector
- Parallel lift Z-bar loader

ENGINE

- C3.3B DIT engine meets U.S. EPA Tier 4 Interim emission certified
- Two stage air cleaner with visual indicator
- Cat Extended Life Coolant, protects to -36° C (-33° F)
- Lockable engine compartments
- Easy quick release fuel filter/water separator
- Engine oil drain valve (non spill eco drain)
- Closed circuit breather
- Hydraulically driven suction fan
- Cold start plugs
- Electric fuel priming pump
- Lockable side door compartments
- Hydraulic oil level sight gauge
- Lockable fuel filler cap
- Radiator expansion bottle

ELECTRICAL

- Cab mounted fuse panel
- Master battery disconnect switch
- Heavy duty, vibration resistant, maintenance free battery, 12V
- Engine cold start aid
- Alternator, 90 Amp
- Service point connector for electronic diagnostics (ET)
- Rooding lights
- Back up alarm
- Reversing light
- High intensity rear lights
- Self-cancelling direction indicators

GENERAL

- Electrostatically applied paint primer
- Hydraulic pressure test points
- Recovery hitch and pin
- Scheduled Oil Sampling (S·O·S) ports
- Lockable fuel filler cap
- Secondary and parking brake
- Recovery hitch and pin
- Front and rear fenders
- Machine lifting/tie down points

OPERATOR ENVIRONMENT

- Multifunction joystick with FNR direction control
- Proportional auxiliary control
- Two external mirrors – knock back
- Warning indicators for major systems
- Easy clean cab floor
- Cup holder
- Sun visor
- ROPS and FOPS certified
- Adjustable wrist rest
- Seat belt, 75 mm (3 in), retractable
- Cabin light
- Internal mirror
- Auxiliary power sockets
- Coat hook
- On board digital LCD display cluster
- Sound suppression
- Heavy duty floor mat
- Storage tray
- Lockable storage box
- Self-cancelling direction indicators
- Interior/exterior auxiliary power sockets
- Suspended brake/accelerator pedals

Optional Equipment

Optional equipment may vary. Consult your Cat dealer for details.

TRANSMISSION/HYDRAULICS

- Transmission control upgrade (includes creeper control, rimpull control and hand throttle)
- Ride control
- Speeder, 35 km/h (21.7 mph) with secondary steering and front axle with hydraulically boosted oil immersed disc brakes

LOADER

- High flow auxiliary hydraulics with pressure relieving quick disconnect manifold
- Return to dig work tool positioner

ENGINE

- Engine block heater, 120V
- Cat extended life coolant, protects to -50° C (-58° F)
- Precleaner for engine air filter

ELECTRICAL

- Machine Security System (MSS)
- Rotating beacon
- Work tool wiring harness
- Working lights, two front and two rear

GENERAL

- Custom color paint
- Rear light guard kit
- Tire options including heavy duty tires

WORK TOOLS

- For all work tools and standard/high flow options, consult your Cat dealer

OPERATOR ENVIRONMENT

- Cat radio/CD/MP3/WMA
- Rear sun screen
- Canopy includes:
 - Steering column, fixed
 - Seat, adjustable suspension, vinyl
- Cab, Comfort (pressurized) includes:
 - Two doors (left door includes sliding window)
 - Seat, adjustable suspension, cloth
 - Steering column, tilt
 - Heater with window, side and foot vents
 - Heated rear window
 - Wiper/washer front and rear
 - Radio-ready kit including speakers
- Cab, Deluxe (pressurized) includes all of the operator benefits of the Cab Comfort model plus:
 - Air conditioning
 - Heated cloth air suspension seat
 - Right sliding window

906H2, 907H2, 908H2 Compact Wheel Loaders

For more complete information on Cat products, dealer services, and industry solutions, visit us on the web at www.cat.com

© 2013 Caterpillar Inc.
All rights reserved

Materials and specifications are subject to change without notice. Featured machines in photos may include additional equipment. See your Cat dealer for available options.

CAT, CATERPILLAR, SAFETY.CAT.COM, their respective logos, "Caterpillar Yellow" and the "Power Edge" trade dress, as well as corporate and product identity used herein, are trademarks of Caterpillar and may not be used without permission.

AEHQ6842 (02-2013)

