



# C7 ACERT™ Industrial Engine

Tier 3/Stage IIIA  
187 bkW/250 bhp @ 2200 rpm



Image shown may not reflect actual engine

## CAT® ENGINE SPECIFICATIONS

### I-6, 4-Stroke-Cycle Diesel

|   |                              |
|---|------------------------------|
| Bore.....                                 | 110.0 mm (4.33 in)           |
| Stroke.....                               | 127.0 mm (5.0 in)            |
| Displacement.....                         | 7.2 L (442 in <sup>3</sup> ) |
| Aspiration.....                           | Turbocharged ATAAC           |
| Compression Ratio.....                    | 17:1                         |
| Rotation (from flywheel end).....         | Counterclockwise             |
| Lube Oil System (refill).....             | 28 L (7.4 U.S. gal)          |
| Weight, Net Dry (approximate kg, lb)..... | 588 kg (1296 lbs)            |

## FEATURES

### Emissions

Meets U.S. EPA Tier 3, EU Stage IIIA emission requirements.

### Worldwide Supplier Capability

Caterpillar  
- Casts engine blocks and heads  
- Machines critical components  
- Assembles complete engine  
- Factory-designed systems built at Caterpillar ISO 9001:2000 certified facilities  
- Ownership of these manufacturing processes enables Caterpillar to produce high quality, dependable product.

### Testing

Prototype testing on every model:  
- proves computer design  
- verifies system torsional stability  
- functionality tests every model

Every Caterpillar engine is dynamometer tested under full load to ensure proper engine performance.

### Full Range of Attachments

Wide range of bolt-on system expansion attachments, factory designed and tested.

### Unmatched Product Support Offered Through Worldwide Caterpillar Dealer Network

More than 1,500 dealer outlets  
Caterpillar factory-trained dealer technicians service every aspect of your industrial engine  
99.7% of parts orders filled within 24 hours worldwide  
Caterpillar parts and labor warranty  
Preventive maintenance agreements available for repair before failure options

Scheduled Oil Sampling program matches your oil sample against Caterpillar set standards to determine:

- internal engine component condition
- presence of unwanted fluids
- presence of combustion by-products

### Web Site

For all your industrial power requirements, visit [www.cat-industrial.com](http://www.cat-industrial.com).



## C7 ACERT™ Industrial Engine

Tier 3/Stage IIIA

187 bkW/250 bhp @ 2200 rpm

### STANDARD ENGINE EQUIPMENT

---

#### **Air Inlet System**

Air to air aftercooled (ATAAC)  
Turbocharged

#### **Control System**

Electronic governing, PTO speed control  
Programmable ratings  
Cold mode start strategy  
Automatic altitude compensation  
Power compensation for fuel temperature  
Programmable low and high idle and total engine limit  
Electronic diagnostics and fault logging  
Engine monitoring system  
J1939 Broadcast (diagnostic and engine status)  
ADEM™ A4 Electronic Control Unit (ECU)

#### **Cooling System**

Thermostats and housing, vertical outlet  
Jacket water pump, centrifugal  
Water pump, inlet

#### **Exhaust System**

Exhaust manifold, dry  
Optional exhaust outlet

#### **Flywheels and Flywheel Housing**

SAE No. 1 Flywheel housing

#### **Fuel System**

HEUI™ injection  
Fuel filter, secondary (2 micron high performance)  
Fuel transfer pump  
Fuel priming pump  
ACERT™ Technology

#### **Lube System**

Crankcase breather  
Oil cooler  
Oil filler  
Oil filter  
Oil pan front sump  
Oil dipstick  
Oil pump (gear driven)

#### **General**

Paint, Caterpillar Yellow  
Vibration damper  
Lifting eyes



**C7 ACERT™  
Industrial Engine**

Tier 3/Stage IIIA

187 bkW/250 bhp @ 2200 rpm

**PERFORMANCE CURVES**

**IND - C (Intermittent) - DM9221-01**

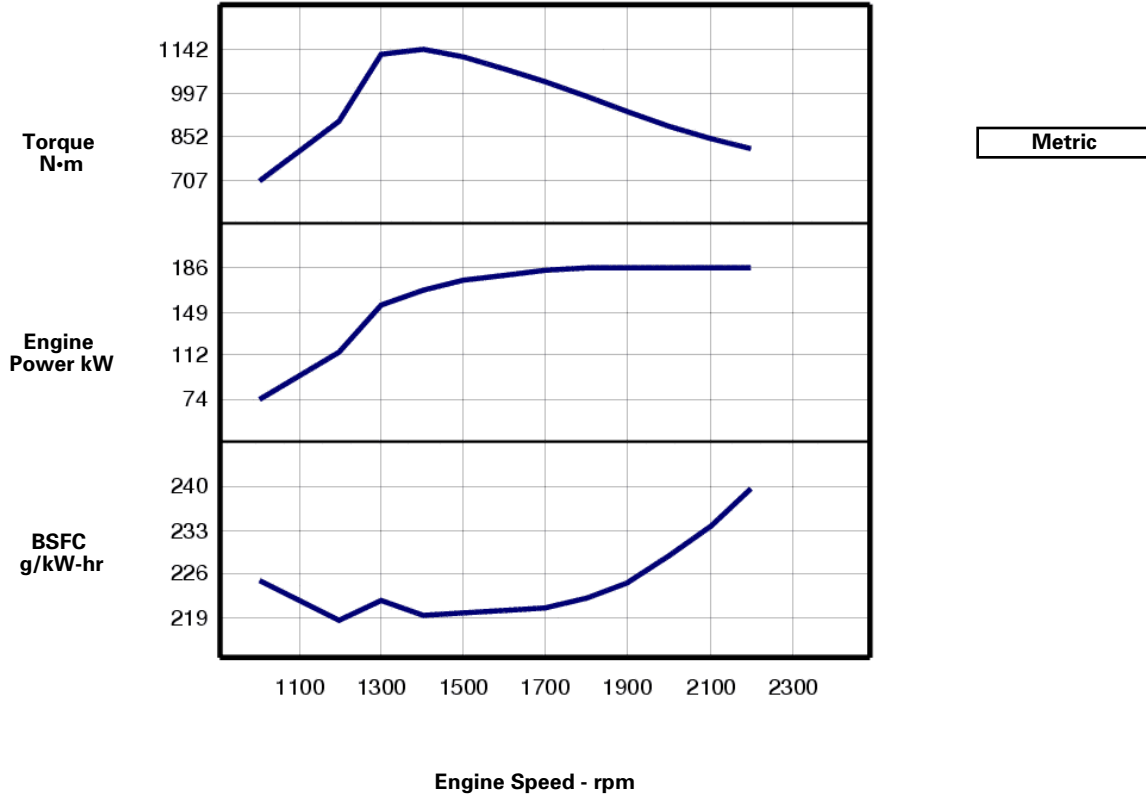

| Engine Speed rpm | Engine Power kW | Torque N·m | BSFC g/kW-hr | Fuel Rate L/hr |
|------------------|-----------------|------------|--------------|----------------|
| 2200             | 187             | 810        | 239.7        | 53.3           |
| 2100             | 187             | 848        | 233.7        | 52.0           |
| 2000             | 187             | 890        | 228.7        | 50.8           |
| 1900             | 187             | 937        | 224.4        | 49.9           |
| 1800             | 187             | 989        | 222.2        | 49.4           |
| 1700             | 184             | 1035       | 220.6        | 48.4           |
| 1600             | 180             | 1077       | 220.1        | 47.3           |
| 1500             | 175             | 1115       | 219.7        | 45.9           |
| 1400             | 167             | 1142       | 219.4        | 43.8           |
| 1300             | 154             | 1128       | 221.8        | 40.6           |
| 1200             | 114             | 906        | 218.5        | 29.7           |
| 1000             | 74              | 707        | 224.9        | 19.8           |



**C7 ACERT™  
Industrial Engine**

Tier 3/Stage IIIA

187 bkW/250 bhp @ 2200 rpm

**PERFORMANCE CURVES**

**IND - C (Intermittent) - DM9221-01**

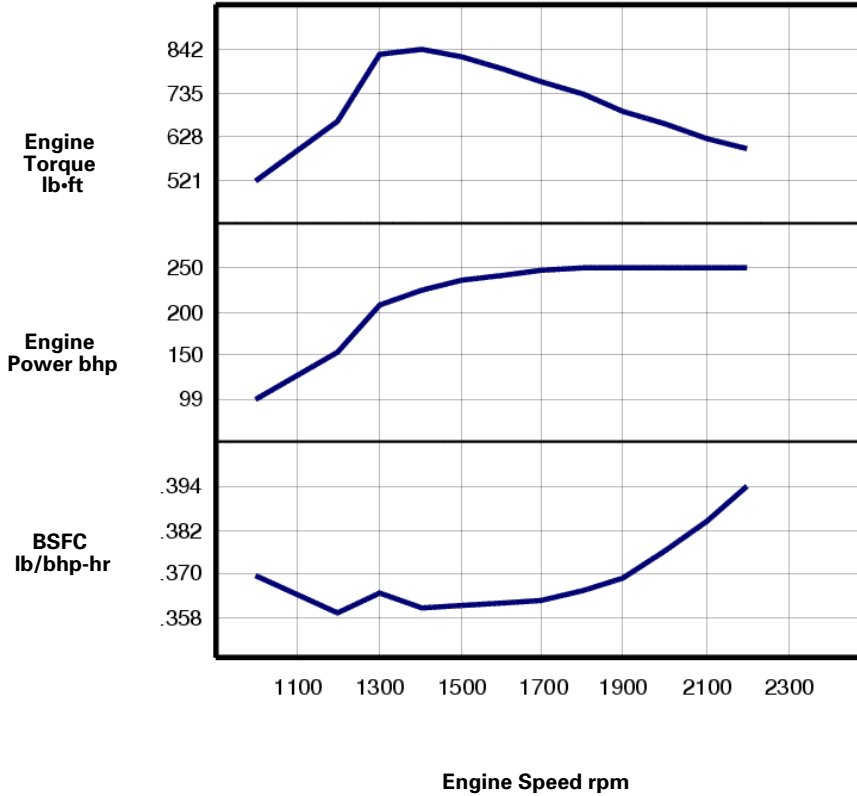

English

| Engine Speed rpm | Engine Power bhp | Engine Torque lb-ft | BSFC lb/bhp-hr | Fuel Rate gal/hr |
|------------------|------------------|---------------------|----------------|------------------|
| 2200             | 250              | 597                 | .394           | 14.1             |
| 2100             | 250              | 625                 | .384           | 13.7             |
| 2000             | 250              | 656                 | .376           | 13.4             |
| 1900             | 250              | 691                 | .369           | 13.2             |
| 1800             | 250              | 729                 | .365           | 13.1             |
| 1700             | 247              | 763                 | .363           | 12.8             |
| 1600             | 242              | 794                 | .362           | 12.5             |
| 1500             | 235              | 822                 | .361           | 12.1             |
| 1400             | 224              | 842                 | .361           | 11.6             |
| 1300             | 206              | 832                 | .365           | 10.7             |
| 1200             | 153              | 668                 | .359           | 7.8              |
| 1000             | 99               | 521                 | .370           | 5.2              |



# C7 ACERT™ Industrial Engine

Tier 3/Stage IIIA

187 bkW/250 bhp @ 2200 rpm

## RATINGS AND CONDITIONS

**IND - C (Intermittent)** Intermittent service where maximum power and/or speed are cyclic (time at full load not to exceed 50%).

**Engine Performance Diesel Engines** — 7 liter and higher All rating conditions are based on SAE J1995, inlet air standard conditions of 99 kPa (29.31 in. Hg) dry barometer and 25°C (77°F) temperature. Performance measured using a standard fuel with fuel gravity of 35° API having a lower heating value of 42,780 kJ/kg (18,390 btu/lb) when used at 29° C (84.2° F) with a density of 838.9 g/L.

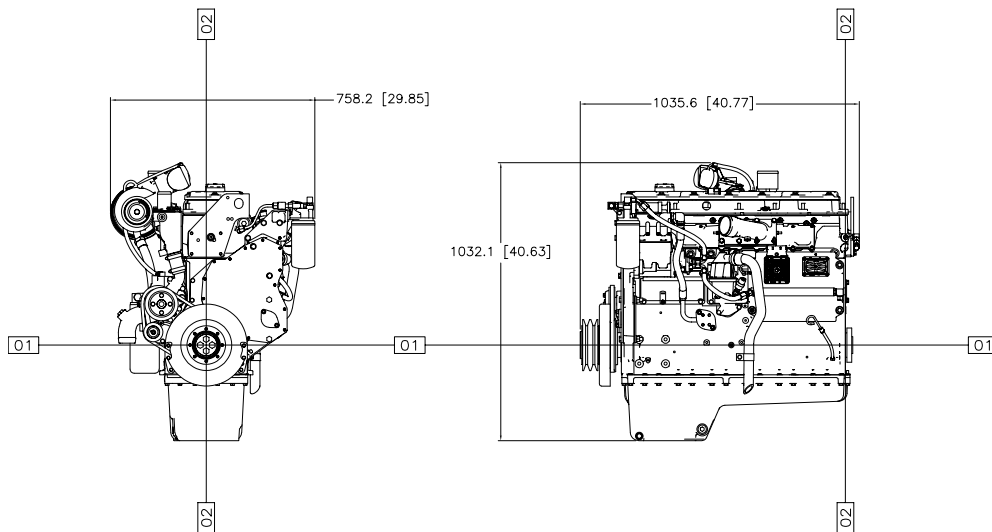

### Engine Dimensions

|            |                      |
|------------|----------------------|
| (1) Length | 1052.7 mm (41.44 in) |
| (2) Width  | 758.2 mm (29.85 in)  |
| (3) Height | 1032.1 mm (40.63 in) |

Note: Do not use for installation design. See general dimension drawings for detail (Drawing # 2835788 ).

Performance Number: DM9221-01

Feature Code: C07DI01 Arr. Number: 2666732

Materials and specifications are subject to change without notice.

16302724

© 2012 Caterpillar

All rights reserved.

The International System of Units (SI) is used in this publication.

CAT, CATERPILLAR, their respective logos, "Caterpillar Yellow," the "Power Edge" trade dress, as well as corporate and product identity used herein, are trademarks of Caterpillar and may not be used without permission.