

MD5150

Track Drill



Specifications

Hole Diameter Range	88.9 mm-152.4 mm	3.5 in-6.0 in
Hole Depth Maximum	31 m	102.5 ft
Engine – Cat® C11 Tier 3	287 kW (385 hp) @ 1,800 rpm	
Compressor	15.1 m ³ /min	534 cfm
Rock Drill HPR5128	28 kW	38 hp

MD5150 Features:

New Carousel Rod Changer

Enjoy increased productivity with our new carousel rod changer that dramatically reduces your rod change time.

Rock Drill

Lower your ownership cost with Cat® Rock Drills. They are simple enough to be owner serviced yet renowned for their strength and long life in hard rock drilling.

Power Group

Fast cycle times are achieved through top of class air capacity, horsepower, and a multitude of time-saving systems for maximum efficiency.

Solid Structures

Designed for long life, the MD5150 withstands your harsh drilling conditions thanks to its' heavy-duty mainframe and undercarriage.

Operator Safety and Comfort

Our fully equipped and quiet cabs keep your operators comfortable, productive and safe.

Serviceability and Customer Support

Easy maintenance and a long life cycle is yours with high quality Cat Drills and reliable customer support.

Contents

Carousel Rod Changer	4
Rock Drills	6
Power Group	8
Cab Safety	10
Cab Comforts	11
Solid Structures.....	12
Dust Collection	14
Technology	15
Drill More. Service Less.	16
Safety	18
Sustainability	20
Specifications.....	21
Standard Equipment.....	25
Optional Equipment.....	26



Drillers Advantage

More Power. Big air. Blazing fast set ups.



Maximum productivity is the advantage with the Cat MD5150 Track Drill. Fast cycle times and a low operating cost are achieved through our customer-inspired designs such as top of class power, air, fast set-ups and a reliable rock drill. Equipment life cycle is long thanks to our durable Cat components and maintenance friendly designs.

Carousel Rod Changer

Fast. Strong. Dependable.



To improve your overall productivity, our new carousel rod changer significantly reduces rod change time. Additionally the carousel is supported by a sturdy feed and the extension boom allowing for large pattern coverage so fewer set ups are required.

Unlike linear alternatives, our carousel rod changer weighs less and holds more rods, allowing the boom extension to reach further and drill deeper while maintaining stability. The feed and carousel rod changer can accommodate multiple lengths and diameters of drill steel.

Additional Features

- Six rod carousel
- Drill steel diameters 51 mm, 60 mm and 68 mm
- Drill steel lengths 3.66 m or 4.27 m (12 or 14 ft) with a 6.1 m (20 ft) starter rod
- Deep multi-pass hole depth to 31.1 m (102 ft)
- Unique gate design always keeps a rod in position; ready to load
- Multiple functions are run simultaneously to save process time
- Heavy-duty, dual rod grippers assist with rod changes and are sized to last
- Patented breakout wrench system, used in conjunction with the dual rod grippers, helps break loose stubborn joints, saves time and eliminates damage to centralizers
- Precise positioning function indexes and locks, eliminating the need for troublesome switches and sensors that are failure prone due to the elements and vibration
- Indexing the rods allows for even wear and longer life of drill rods
- Corrosion resistant and self-lubricating pivot points eliminate manual lubrication



Sturdy Boom and Feed Support the Carousel Rod Changer

- The 2.4 m (8 ft) boom extends an additional 0.9 m (3 ft) for larger pattern coverage with fewer set ups
- The boom swing capability is 9° L to 29° R for wide pattern coverage
- Heavy-duty boom is constructed of thick square tubing with steel plate reinforcements in key areas to add strength
- Feed table is 2.7 m (9 ft) with a 0.9 m (3 ft) extension. It resists torsion and thrust loads due to high strength steel channels with diagonal internal bracing.
- A new, patented, hose tensioning method keeps hoses on the drum, sheaves are used to prolong long hose life and a feed chain auto-tensioner feature reduces adjustment time
- Feed wear pads are replaceable with patent pending adjusters
- Planetary gearbox feed drive is capable of 4354 kg (9,600 lb) feed force and 36.9 mpm (121 fpm) speed
- LED lighting on the feed illuminates the carousel and hole site for around the clock drilling

Rock Drills

Reliable. Durable. Low operating cost.



Standard on the MD5150 is the HPR5128 hydraulic powered percussion rock drill rated at 28 kW (37.5 hp) output energy with dual hydraulic variable rotation motors producing 1898 N·m (1,400 lbf-ft) torque

New Automated Rock Drill Lube System

Peak performance is sustained when your rock drill is kept lubricated, cool, and automatically maintained with our new Auto Rock Drill Lube System. Operators no longer have to stop drilling to manually grease the rock drill every two hours.

- Saves more than forty hours a year over manual greasing
- Components reach full life expectancy at proper lube intervals
- Grease reservoir stores supply for up to five 8-10 hour shifts
- A timer board cycles the grease pump throughout the day eliminating maintenance time
- High and low pressure conditions are continually monitored through the display screen



Reliable Performer

Low cost of ownership and reliability are yours with renowned Cat® Rock Drills. Building on a legacy of simplistic power, these drills have long life expectancy and are field serviceable. This combination of robust design and easy maintenance means more hours of reliable, low-cost operation. For added efficiency, the pistons are matched to the cross section of the rod so the wave form is properly matched for maximum energy transfer.

Durable Design

A simple design coupled with high strength materials yields exceptional durability.

- Having only half of the components of competitive models, there are fewer internal parts to wear.
- There are four major housings bolted together with high strength flanges eliminating troublesome long tie rods.
- Long life alloy bushings
- Fast response accumulators provide a smooth and efficient hydraulic oscillation
- Long leakage paths of the oscillator bearings yield high volumetric efficiency

Owner Serviceable

Cat Rock Drills are so simple that owner serviceability is a viable alternative and cost savings.

- Other models require downtime for round trip transportation to a clean room environment
- Only their OEM service technicians can perform the maintenance and repairs
- All maintenance and rebuilds can be done in your shop and some maintenance can even be done with the rock drill still mounted to the feed.
- Accumulator assemblies may be replaced in the field
- Troubleshooting is easy since there are half the components of other drills

Rock Drills for MD5150		
HPR5128 Standard	28 kW	37.5 hp
HPR6030 Option	30 kW	40 hp
HPR6832 Option	32 kW	43 hp



More Power. Big Air.

The MD5150 power group delivers fast cycle times and maximum efficiency due to the combination of top of class air capacity, engine horsepower and an over sized cooler to keep all systems operating at optimal temperatures.

Engine

MD5150 powers through hard rock with its' Cat C11 Tier 3 engine at 287 kW (385 hp) @ 1,800 rpm. The six (6) cylinder engine is electronically controlled, turbocharged, and water-cooled. Fuel conservation, resulting in lower operating cost, is achieved with three speed engine throttle control.

Additional Engine Features

- Engine throttle range – 1,000 rpm, 1,500 rpm and 1,800 rpm
- Altitude before derating 2286 m (7,500 ft)
- Cat dual air filter elements
- Fuel tank 598 liter (158 gal)
- Top-fill oil receiver
- Starter is on right hand side
- Pumps are driven off of the cam tops



Compressor

MD5150 has the largest compressor available, allowing for maximum flushing power.

- High pressure rating 15.1 m³/min (534 cfm) @ 9.6 bar (140 psi) gauge
- Reliable rotary screw-type compressor
- Directly driven gear ratio
- Air filters are common to the engine

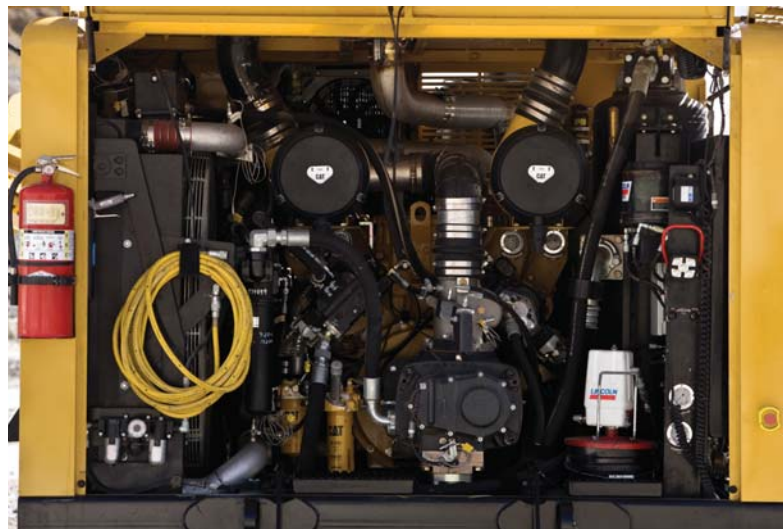

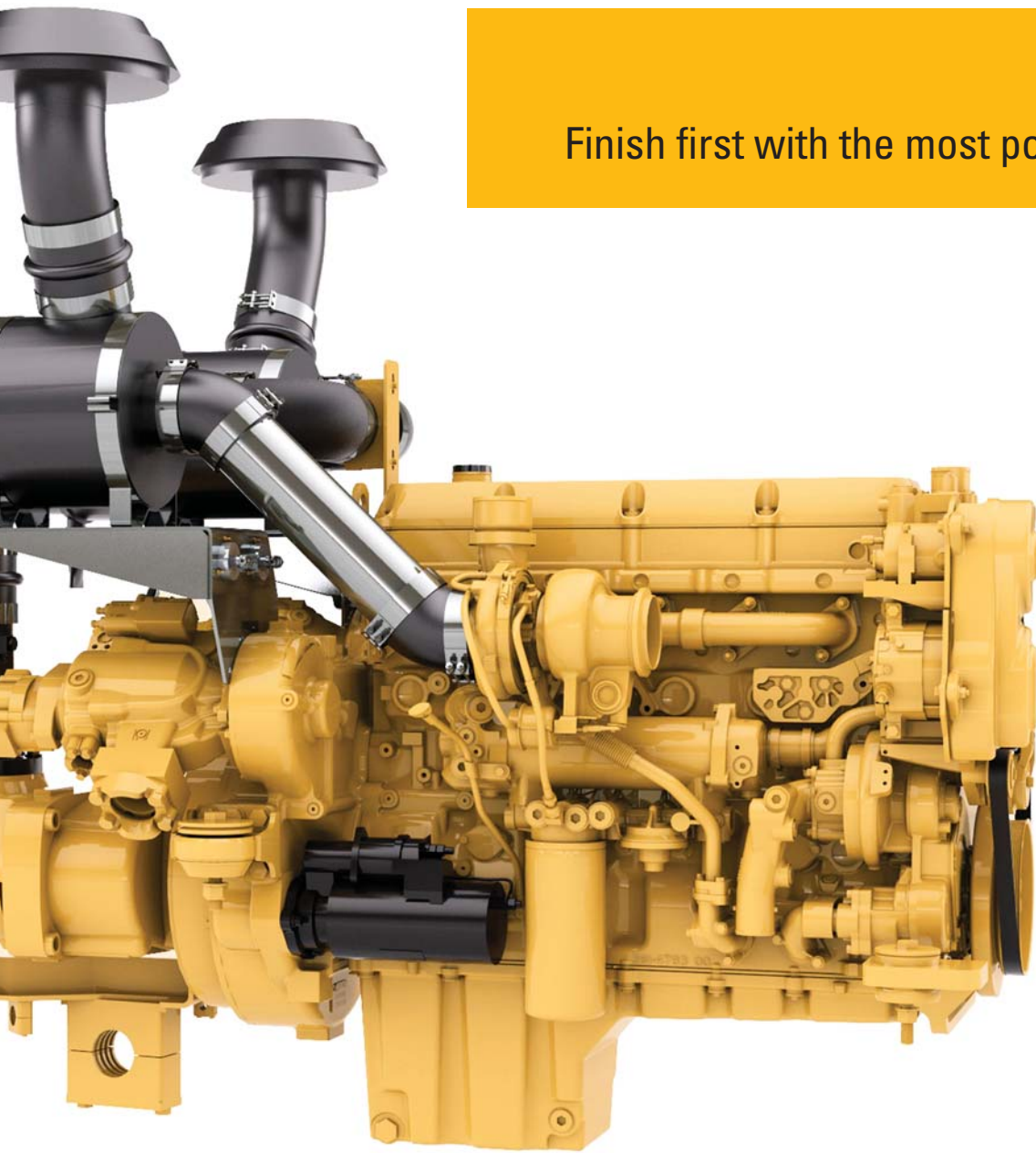

Power Group

Finish first with the most power and air in-class.

Cooler

Highly efficient, the new oversized design and ATAAC side by side arrangement ensures all systems are properly and efficiently cooled.

- 52° C (125° F) ambient temperature
- Proportional controlled fan
- Easy troubleshooting and cleaning of the coils
- Recirculation of hot air is limited by baffles

Cab Safety

Loaded.

Keeping Operators Safe

MD5150 offers a cab with superior safety features from the numerous shutdown methods and a ROPS/FOPS certified cab to responsive controls that minimize fatigue. The cab front window allows for egress, providing a second exit in case of emergency. Because, at the end of the day we all want to go home safely.

Loaded with Safety Features

- High visibility with 3.8 m² (41.76 ft²) tinted safety glass windows
- Slim structure members minimize visual obscurity
- Skylight provides excellent visibility of the drill string and has sliding sunshade
- Mirrors and high-resolution cameras assist in moving the machine
- High resolution monitor for Smart Drill Monitoring System
- Operational lock-out lever in cab seat prevents engine start
- Ground level shutdowns
- Tram control by lever and foot pedal
- To limit slippage, easy-grip pedals and footrest are rubber covered
- Heavy duty handles
- Fire extinguishers
- Large monitor with integrated rearview camera display
- Three speed window wipers

Safety Through Controls

- Dual joystick controls are ergonomic and seat-mounted
- For heightened precision, the position and shape of the CANbus joysticks match the operator's natural expectations
- Thread lube system is operated with a foot switch

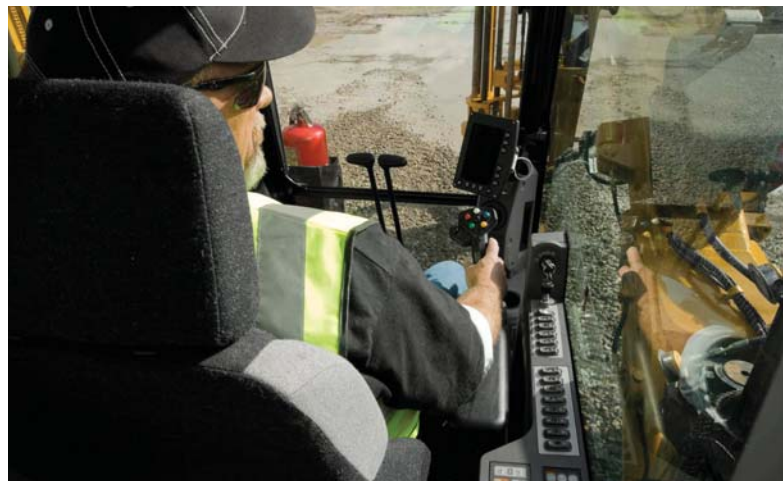



Cab Comforts Plentiful.

Cab

Throughout your shifts, the Cat 349E cab is a quiet and comfortable work environment for relaxed drill operation. It's pressurized so sound levels are less than 80 dB(A) and it's isolator mounted to minimize vibration.

Features

- Climate control system maintains a consistent temperature
- Air is filtered to the operator
- Windows have defrost/defog air
- Windows open for fresh air and communication with others
- Operator's seat is adjustable six ways
- Armrests, controls and switches are ergonomic
- Easy access to cab air filter and fuse box
- AM/FM Radio IPOD/MP3 player ready
- Communications radio ready
- Easy to clean finishes
- Deep storage space and two cup holders
- Two auxiliary power outlets 12V

Smart Drill Monitoring System

Developed to assist novice drillers, the smart drill system increases your overall drill production in difficult drilling conditions. It's a hydraulically operated drilling control system that monitors changes in rock formation and adjusts the impact and feed pressure to the hardness of the rock. It incorporates anti-jam, anti-plunge, and anti-plug and increases overall life of drill string.

You can expect a long life due to the structural integrity of our frames and the robust Cat 315C undercarriage. Despite the unyielding demands of drilling and navigating rough terrain, our structures are continually proven reliable. The frame supports the upper machine weight plus the added hammer pressure of percussive drilling, yet the MD5150 remains extremely maneuverable thanks to its low center of gravity, high ground clearance, and independent track oscillation.

Frame

You can rely on a maintenance free and long lasting base for your drill because each frame is designed and thoroughly inspected in-house. All weld inspections are certified to CWI or CAWI standards.

- High quality steel
- Welds are magnetic particle inspected
- Vibratory stress tested
- Designed to our best-built standards

Undercarriage

Get there faster on a Cat 315C Undercarriage. You can quickly and precisely position the MD5150 at drill patterns thanks to the agility of independent track oscillation. Further, the best-built design and high ground clearance allow you to confidently tram rough terrain between benches.

• Highly Maneuverable

- Dual tram speed 4.0 km/h (2.5 mph)
- Gradeability 35°
- Ground clearance 406 mm (16 in)
- Wide triple grousers 380 mm (15 in)
- Oscillation $\pm 11^\circ$; hydraulic cylinder controlled

• Durable

- Robust strut design is resistant to failures
- Easy installation and removal of shoes
- Rebuildable



Solid Structures

Get long-lasting reliability and performance.



- **Cat Grease Lubricated Track (GLT)**

- Each track joint is sealed to retain the grease between the pin and bushing
- Improves internal wear life by over 25% than sealed track
- Track noise is reduced because there is no metal to metal contact between the pin and bushing
- The grease lubricant prevents frozen or seized track joints
- Overall system wear life is enhanced due to sprocket wear improvements

Dust Collection

Contain it – quickly and quietly.



Powered to clean holes up to 152 mm (6 in), the MD5150 dry dust collection system is efficient, quiet and it consumes less power than traditional dust collectors. The heavy-duty system effectively manages rock fragments and dust yet is also easy to clean and service.

Features

- High capacity working pressure is 7 bar (100 psi)
- The suction fan design limits the power requirement to correspond the application
- Easy top access to filters and air valves
- The sealed pick up pot prevents cuttings from escaping above the hole
- Vacuum generated air flow carries the materials
- Pivoting separator is feed mounted and separates cuttings from dust
- Abrasive resistant dust hose is 152.4 mm (6 in)
- Filtration area is 16 m² (172 ft²) and separates the solid particles from the clean air
- Timed cleaning is continual through reverse-pulses of air

Technology

That makes life easier.

To assist you in your operations and equipment management, we provide numerous technology products that aid in utilization, tracking, planning as well as equipment maintenance and performance monitoring.

Product Link™

Reduce your owning and operating costs by maximizing your utilization. Product Link achieves this through remote fleet monitoring, asset tracking, maintenance management which are reported via satellite and cellular networks. This system allows you to monitor daily fuel usage, route fuel trucks for maximum efficiency and track equipment utilization day by day, hour by hour.

Cat Monitoring System

The MD5150 is equipped with the Cat Monitoring System (Cat MS) which keeps watch over the health of your engine. It monitors critical engine system functions and will derate the engine to protect itself from damage if needed. When critical conditions arise, the Cat MS monitor displays warning lights and sound audible alarms.

Automatic Lubrication Systems

Peak performance is sustained when your components are kept lubricated, cool, and automatically maintained with our new Automatic Lube Systems. A tremendous time saver for you, the MD5150 is equipped with two systems that keep the undercarriage, boom, feed, and rock drill greased at ideal intervals.

Smart Drill Monitoring System

Developed to assist novice drillers, the smart drill system increases your overall drill production when drilling in difficult conditions. It monitors changes in rock formation and adjusts the impact and feed pressure needed based on the hardness of the rock. It incorporates anti-jam, anti-plunge, and anti-plug and increases overall life of drill string.

Electrical System – Cat (ET) Electronic Technician

For easy troubleshooting of the entire machine, the Cat MD5150 Track Drill includes the Cat ET System this is familiar to and favored by service technicians around the world.

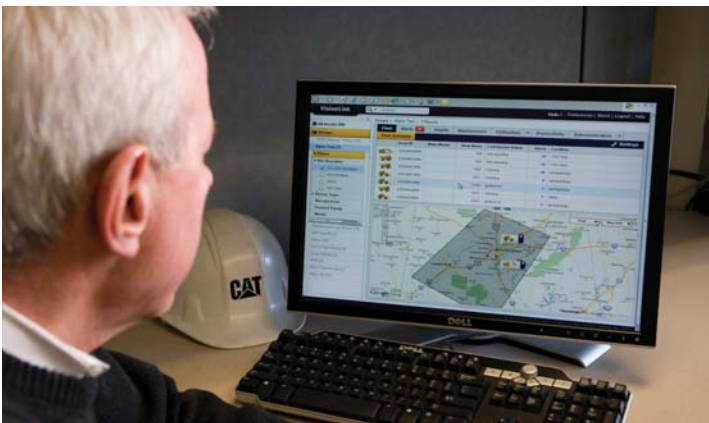

Drill More. Service Less.

Easy access. Simple. Cost effective.

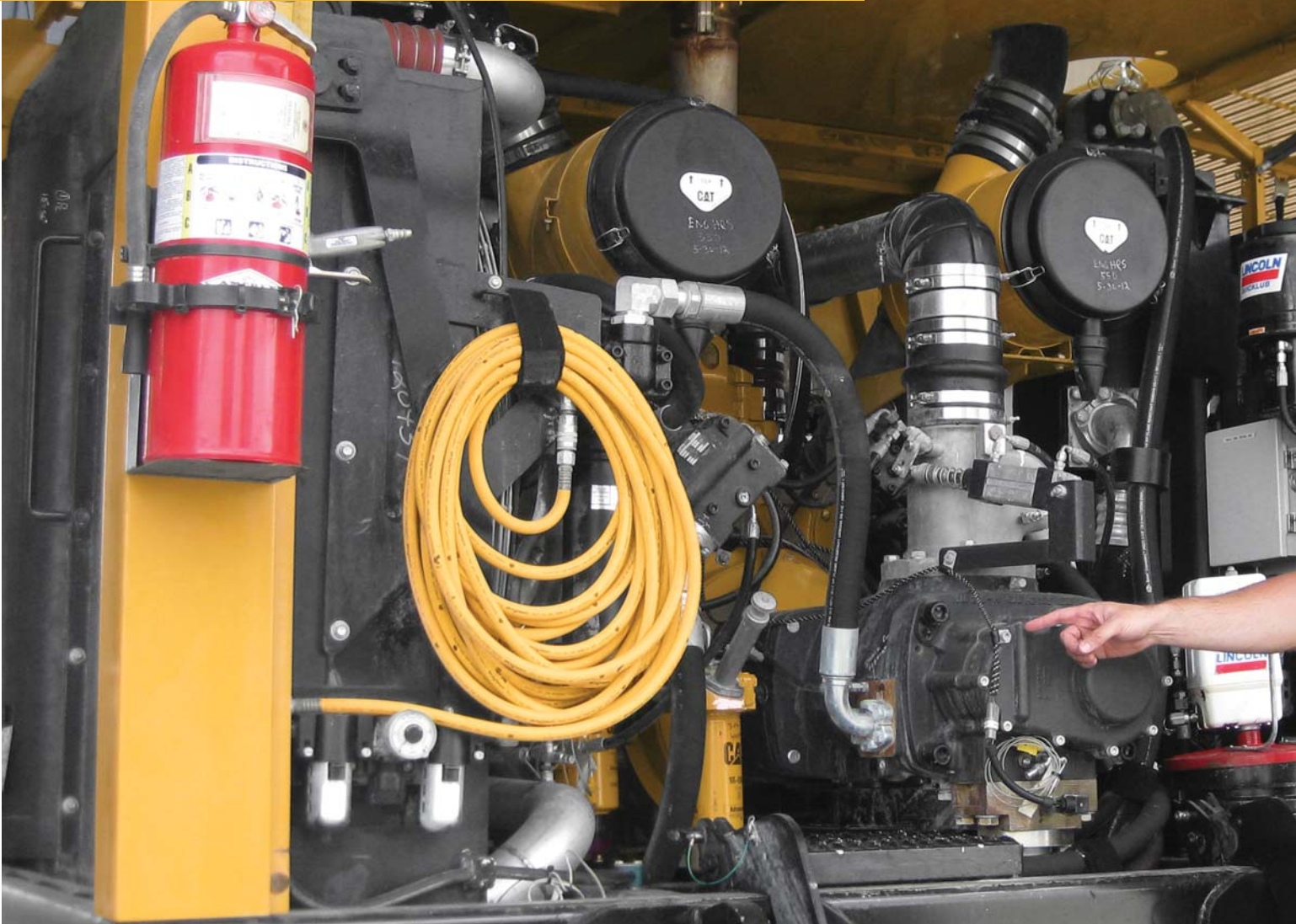

Supported by World-class Cat Dealer Network

From helping you choose the right machine to keeping your equipment up and running, your Cat dealer provides the best in sales and service.

- Preventive maintenance programs are available to maximize your return on investment, achieve full equipment life cycle, and managing costs
- Guaranteed maintenance contracts help you forecast your businesses needs and strategically plan for service and parts expenses
- Best-in-class parts availability because Cat dealers understand the value of your uptime
- Operator training to help boost your productivity
- Genuine Cat Remanufactured parts are available



With the maintenance friendly designs, your service access is safe and efficient. Servicing a Cat Track Drill is very straightforward thanks to well-organized electrical/hydraulic arrangements and logically located components which contribute to its valued simplicity and ease of maintenance. Systems are designed for durability and easy maintenance so your equipment life cycle is long, operating costs are lower and Cat drills maintain a high resale value.

Features

- Cat ET Software is used to troubleshoot the equipment
- Enclosure has gull-wing doors lifted with gas springs
- Interior and exterior LED lighting throughout the drill and under the canopy
- The canopy can be completely removed via four pinning points and lifting lugs
- Electric pump for filling hydraulic tank
- Grease reservoir is easily accessible for changing coupling grease
- Pumps and valves are conveniently arranged for service
- Service areas are designed with three points of contact for safe access
- Hose routings include bulkhead clamps to allow for shorter hose runs and easier replacements

Walk-in Service Station

To further assist you with troubleshooting and maintenance, the MD5150 has a unique walk-in service station inside of the drill enclosure. The water tank swings out allowing covered access to major service points for the engine, compressor, air conditioning, valves for the boom and water injection systems and more. A boom-mounted camera constantly monitors the front of the drill so you have constant visibility when working inside the service center.



Safety

Built-in protection.



Operator Training for Safety

- High quality materials and trainers for operation, maintenance, and service
- Classroom style training available
- Hands-on training with your local Cat dealer



Loaded with numerous safety features, the Cat Track Drills are designed to provide a safe working environment for operators as well as maintenance and service technicians.

MD5150 Track Drill Safety Features

- Non-slip, heavy duty steps and handles are strategically placed
- Three points of contact at all steps
- Quick and easy access to service points
- Four external safety shutdowns at ground level
- Two cameras and two viewing monitors
- Mirrors and high-resolution cameras to assist in safely moving the machine
- LED lighting inside and out, on the feed and in all service compartments
- Flashing motion beacon and alarm
- Slideout battery tray for easy change out
- Fire extinguishers

Walk-in Service Station Safety Features

- Trimming is locked out
- Covered access to major service points
- Camera on the feed allows for total visibility

Cab Safety Features

- ROPS/FOPS cab
- High visibility with 3.8 m² (41.76 ft²) of tinted safety glass
- Slim structure members minimize visual obscurity
- Skylight allows viewing the top of the feed and has a sliding sunshade
- Mirrors and high-resolution cameras assist in safely moving the machine
- High resolution monitor for Smart Drill Monitoring System
- Operational lock-out lever in cab seat prevents engine start and operation
- Ground level shutdowns
- Tram control by lever or foot pedal
- Easy-grip pedals and footrest are rubber covered
- Heavy duty handles
- Fire extinguishers
- Three speed window wipers



Sustainability

For generations to come.



To increase efficiency and productivity for you, Cat Drill designs leverage technology and innovations that help to minimize the environmental impact of mining. We strive to provide products, services and solutions that use our natural resources wisely.

MD5150 Sustainability Features

- Fuel economy is achieved with three speed throttle control
- Product Link for optimum fleet management
- Smart Drill Monitor automatically adjusts power to the rock condition requirements
- Auto lube systems are clean and efficient
- Remanufactured components are available
- Major components can be rebuilt



MD5150 Track Drill Specifications

General Data

Hole Diameter Range	88.9 mm- 152.4 mm	3.5 in- 6.0 in
Hole Depth Maximum	31 m	102.5 ft
Engine – Cat C11 Tier 3	287 kW (385 hp) @ 1,800 rpm	
Compressor	15.1 m ³ /min	534 cfm
Rock Drill HPR5128	28 kW	38 hp

Dimensional Specifications and Weights

Operating Length	7.62 m	25 ft
Tramming Length	10.62 m	34 ft 10 in
Shipping Length	11.45 m	37 ft 7 in
Shipping Width	2.59 m	8 ft 6 in
Shipping Height	3.51 m	11 ft 6 in
Shipping Weight (base machine)	20 411 kg	45,000 lb

Undercarriage

Wide Triple Grouser Pads	380 mm	15 in
Gradeability	35°	
Ground Clearance	400 mm	15.75 in
Ground Pressure	0.91 bar	13.2 psi
Track Gauge	2032 mm	80 in
Tram Speed (2 speed)	1.61/ 4.02 km/h	1.0/ 2.5 mph

- Track Oscillation ±11°
- Hydraulic motor-driven track assemblies with towing disconnects
- Cat 315C
- Spring applied disc brakes
- Triple rock grousers

Power Train

Cat C11 Tier 3 Diesel @ 1,800 rpm	287 kW	385 hp
Ambient Temperature Capability	52° C	125° F
Altitude Before Derating	2286 m	7,500 ft
Fuel Tank	598 L	158 gal

- Six (6) cylinder, electronically controlled, water-cooled, turbocharged and air-to-air after-cooled
- Three position engine rpm throttle 1,000 rpm, 1,500 rpm and 1,800 rpm
- Cat dual air filter elements

Cooler Package

@ 2,000 rpm	654 m ³ /min	23,100 cfm
Fan Assembly	1067 mm	42 in

- AKG four vertical sections; compressor, engine, hydraulic and air after cooler
- Sized for ambient capability of 52° C (125° F)
- Hydraulic fan drive with temperature compensated speed control

Hydraulic System

- Pressure compensated axial piston pumps running at 2,340 rpm
- Cooling fan with axial piston variable control pump
- Dust collector gear pump
- Convenient pressure gauges and test taps installed
- Full flow 5 micron filtration
- Electric fill pump
- 416 L (110 gal)
- Full flow cooling
- Sight gauge with electronic safety shutdown on low level

Air Compressor

Engine Direct Driven	252 L/sec @ 9.6 bar	534 cfm @ 140 psi
----------------------	------------------------	----------------------

- Screw-type compressor
- Direct drive 1.25 gear ratio running at 2,250 rpm
- Dual filter elements

Shutdown Features

- Low engine oil pressure
- High engine water temperature
- High compressor discharge temperature
- Low hydraulic oil level
- Emergency stop (4 locations)

Instrumentation

- Tachometer
- Fuel gauge
- Water temperature
- Engine hour meter
- Drill hour meter
- Drill mode meter
- Tram mode meter
- Oil pressure
- Fuel consumption
- Compressor temp
- Voltage
- Drill rotation pressure
- Drill hammer pressure
- Drill feed pressure
- Blow air pressure

MD5150 Track Drill Specifications

Dust Collecting System

Filter Area	16 m ²	172 ft ²
Abrasive Resistant Suction Hose	152.4 mm	6 in
Top Change Filter Elements	Quantity 4	

- Dust collector sized to clean holes up to 165.1 mm (6.5 in) in diameter
- Hydraulic motor powered, dry dust collecting system
- Programmable pneumatic filter purge system
- Reverse pulse filter cleaning system
- Feed-mounted dual axis pre-cleaner
- Hydraulically operated and positional dust pickup pot

Cab

Total Glass	4.66 m ²	50.16 ft ²
-------------	---------------------	-----------------------

- Cat 349E cab
- ROPS/FOPS certified
- Digital engine and drill readout system
- CANbus joysticks in both armrests
- Noise rating less than 80 dB(A)
- Tinted sliding windows
- Reversing camera
- Heater/AC pressurizer and coils mounted in cab
- Front washer and wiper
- AM/FM radio
- CB Radio (optional)
- 110V AC outlet
- Six way adjustable seat; forward/back, up/down and reclining
- Emergency egress
- Foot pedal and handle tram controls
- Auto thread greaser at right foot
- Console pocket for drill log, from camera screen, lunch box, drink holder and miscellaneous storage
- Coat hook
- Driller lunch box/cooler storage behind seat

Controls in Cab

- Key switch
- Safety switch
- Two armrest joystick controls (both with dual axis and left with six buttons and right with seven buttons)

Left joystick	Right joystick
Tram/setup mode	Tram/setup mode
1st Drill functions	1st Drill functions
2nd Drill functions	2nd Drill functions
3rd Drill functions	3rd Drill functions
- Remote feed force control knob
- Remote water output flow control knob
- Seven dedicated switches
 - High idle
 - Drill/tram
 - Dust collector
 - Smart drill
 - Seven LED drill lights (three selections)
 - Wiper (three selections)
 - Washer
 - Warm oil

Smart Drill Drilling System

- Operator-selected, smooth, electrical control system for all drilling functions
- Monitors main hydraulic system (hammer, feed, air and rotation pressure) and automatically adjusts to pre-programmed parameters
- Minimizes overfeeding
- Anti-plug
- Anti-plunge
- Anti-jam

Boom System

Boom Length	2.7 m	9 ft
Boom Extension (inner boom extension)	0.91 m	3 ft
Boom Swing	9° L to 29° R	
Boom Lift Above Horizontal	25°	
Boom Dump Below Horizontal	8°	
Extendible Offset Feed Table	0.91 m	3 ft
Feed Swing	15° L to 36° R	

Feed System

High Strength Steel Channels (2)	177.8 mm	7 in
Pitch Roller Chain and Sprockets	38.1 mm	1.5 in

- Feed with rod changer for six 3.66 m (12 ft) steel rods of 51, 60, 68 mm
- Drill mounting slide
- Replaceable wear pads with adjusters
- Automatic hydraulic feed chain tensioner
- Planetary gearbox feed drive capable of 42 703 N (9,600 lb) feed force and 36.9 m/min (121 fpm) speed
- Headache rack for tram and transport
- Highly visible hose reel

Carousel Rod Changer System

Rod Length	3.66 m or 4.27 m	12 ft or 14 ft
Rod Diameters	51 mm, 60 mm and 68 mm	
Starter Rod	6.1 m	20 ft
Single Pass Depth	5.63 m	18.5 ft
Multi-pass Depth	31.1 m	102 ft

- Patent pending breakout system
- Anti-corrosion/self lubricating coatings on pins
- Traveling and locking centralizer
- Hose tensioners
- Manual and digital dual axis angle indicator
- Dual heavy duty gripper arms
- LED flood light
- Air/grease coupling lubrication system

Rock Drill

HPR5128 Output Energy	28 kW	37.5 hp
Weight	408.2 kg	900 lb
Rod Diameter Choices	51 mm, 60 mm or 68 mm	
Blow Rate	2500-2700 bpm	

Percussion Pressure	Up to 200 bar	Up to 2,900 psi
---------------------	---------------	-----------------

Optional HPR6030 Rock Drill

Output Energy	30 kW	40 hp
Dual Hydraulic Variable Rotation Motors Producing	2033 N·m	1,500 ft-lb
Weight	397 kg	877 lb
Rod Diameter Choices	51 mm, 60 mm or 68 mm	
Percussion Pressure	Up to 200 bar	Up to 2,900 psi
Blow Rate	2500-2700 bpm	

Optional HPR6832 Rock Drill

Output Energy	32 kW	43 hp
Dual Hydraulic Variable Rotation Motors Producing	2033 N·m	1,500 ft-lb
Weight	408 kg	900 lb
Rod Diameter Choices	51 mm, 60 mm or 68 mm	
Percussion Pressure	Up to 200 bar	Up to 2,900 psi
Blow Rate	2500-2700 bpm	

- Dual hydraulic variable rotation motors producing 1898 N·m (1,400 lbf-ft) torque
- Optional Rock Drill Auto Lube System

Gauges (installed)

At Boom Valve	Inlet pressure Drill rotation pressure Feed pressure Relief pressure Auxiliary pressure
At Tram Console	Dust collector hydraulic pressure Dust collector air pressure Hammer pressure Left track pressure Right track pressure
At CRC Valve	Inlet pressure Tensioner pressure
At Feed Bulkhead	Drill supply pressure Drill return pressure Case drain manifold pressure 2X Compressor air pressure Thread lube pump air pressure Auxiliary air pressure Electric fluid fill pump filter pressure Case drain filter pressure Hydraulic return filter pressure

Safety

- Feed swipe rope engine shut off
- Four large top opening access doors assisted with gas springs
- Two fixed interior LED lights and one magnetic movable LED light
- Two exterior rear facing LED lights
- Four LED lights on front of the cab facing forward and one on top of the feed facing down to hole
- Five, three point access areas
- Flashing motion beacon and motion alarm
- Two cameras and two viewing monitors
- Four safety switches
- Two 9.1 kg (20 lb) fire extinguishers
- Rearview camera mounted on rear access door
- Heavy duty steps and handles are strategically placed and non-slip
- Three points of contact at all steps
- Four external safety shutdowns at ground level
- Tram interlock switch at service access area
- Mirrors and high-resolution cameras are standard to assist in safely moving the machine
- Slide out battery tray for easy change out

MD5150 Track Drill Specifications

Dimensions

All dimensions are approximate.

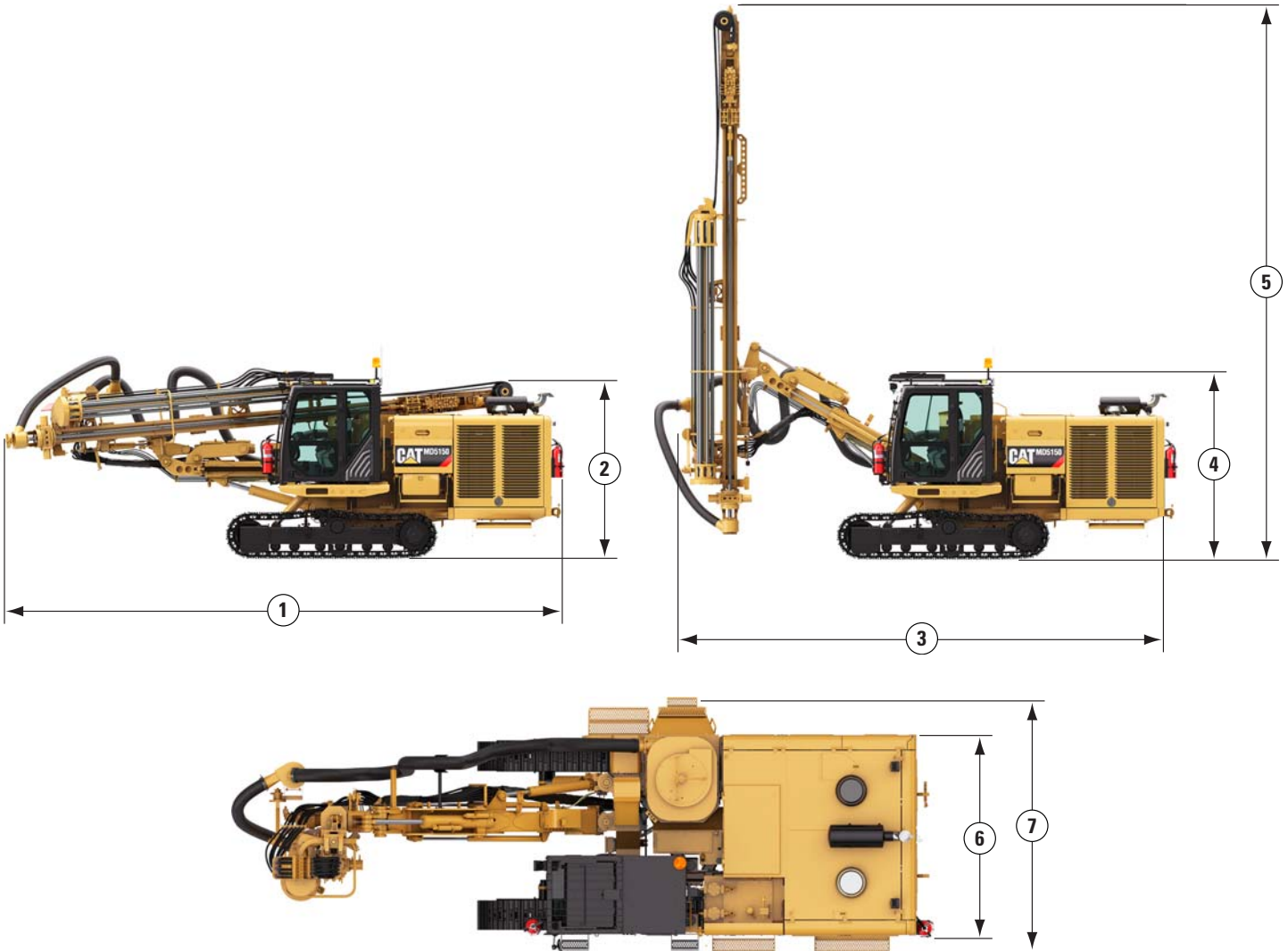

1 Length in Tram Position	10.8 m	35 ft 2 in
2 Height in Tram Position	3.4 m	11 ft 2.5 in
3 Length in Drilling Position	8.1 m	26 ft 5.47 in
4 Height to Top of Cab	3.2 m	10 ft 7.33 in
5 Height to Top of Feed	9.2 m	30 ft 3.14 in
6 Width for shipping (less dust hood)	2.6 m	8 ft 6.55 in
7 Overall Width	3.3 m	10 ft 9.29 in

Standard Equipment

Standard equipment may vary. Consult your Cat dealer for details.

TRACK UNDERCARRIAGE

- Cat 315C lower arrangement
- Hydraulic motor-driven track assemblies with towing disconnects
- 380 mm (15 in) wide grousers
- $\pm 11^\circ$ hydraulic cylinder controlled track oscillation
- Hydraulic released spring applied disc brakes and triple rock grousers
- Dual tramping speed 1.6/4.0 km/h (1.0/2.5 mph)

POWER

- Cat C11 Tier 3, six (6) cylinder, electronically controlled, water-cooled, turbocharged and air-to-air after-cooled diesel engine rated at 287 kW (385 hp) at 1,800 rpm
- Three speed throttle control for fuel conservation

HYDRAULIC SYSTEM

- Two main 105 cc (6.4 in³) pressure compensated axial piston main pumps
 - One dedicated cooling 38 cc (2.3 in³) fan pump pressure compensated axial piston piggy-back mounted off the left main pump
 - One dedicated dust collector 21 cc (1.3 in³) gear pump piggy-back mounted off the right main pump

COMPRESSOR

- Engine direct driven 252 L/sec @ 9.6 bar (534 cfm @ 140 psi) screw-type compressor

BOOM SYSTEM

- 2.7 m (9 ft) extension boom with 0.91 m (3 ft) inner boom extension
- The boom swing capability is 9° L to 29° R
- The boom is mounted on a 0.91m (3 ft) extendible offset feed table

FEED SYSTEM

- Model HUFH20 hydraulic motor-driven steel channel chain feed weldment complete with the power centralizer, manual and electronic angle inclinators, unique hose sheaves and patented feed chain tensioner
- Equipped with replaceable wearpads
- The HUFH20 feed will change a 6.10 m (20 ft) starter drill steel inside the centralizer

ROCK DRILL

- Model HPR5128 hydraulic powered percussion drill rated at 28 kW (37.5 hp) output energy with dual hydraulic variable rotation motors producing 1898 N·m (1,400 lbf-ft) torque

CAB

- Cat 349E cab complete with heater, air conditioner, wiper, four (4) drilling lights and all necessary drilling controls
- ROPS/FOPS certified
- AM/FM stereo
- Receptacle for auxiliary charger
- Comfortable six way adjustable operator's seat
- Tinted, sliding windows

ROD CHANGER

- Carousel for 6 × 4.2 m (14 ft) steel
- Hydraulic centralizer and patented drill joint breakout system
- Unique mechanical drive and locking system for rod indexing
- Patented hose tensioner
- Patented wearpad adjustment
- Patented anti-corrosion, self-lubricating pivot points
- Changeable rod gripper inserts and rod retainers
- LED light
- Dual HD rod grippers

CONTROLS

- The tram, drill setup, feed, rotation, rod changer and blowing air controls are mounted in the cab
- Manual tram, drill setup, feed, rotation and rod changer controls are located at easy to access service positions

DUST COLLECTING SYSTEM

- Hydraulic motor powered, dry dust collecting system with four top service filters
- Programmable pneumatic filter purge system
- Dual axis patented precleaner mounting
- Hydraulic operated pick up pot
- 152 mm (6 in) abrasive resistant suction hose

OTHER STANDARD FEATURES

- Foot pedal coupling greaser operated from cab, collaring and Smart-drill drilling modes
- Engine enclosure with four large top opening access doors assisted with gas springs, two fixed interior LED lights and one magnetic movable LED light, two exterior rear-facing LED lights
- Rearview camera mounted on rear access door
- Four pinning points and lifting lugs for quick easy removal of canopy
- Electric hydraulic fill pump
- Five, three point access areas
- Flashing motion beacon and motion alarm
- Four safety switches
- Two 9.1 kg (20 lb) fire extinguishers
- Slideout battery tray
- Cat Electronics

MD5150 Optional Equipment

Optional Equipment

Optional equipment may vary. Consult your Cat dealer for details.

- Less dust collector and precleaner
- 303 L (80 gal) detergent system
- Six carousel rod changer conversion kit 60 mm drill rod
- Six carousel rod changer conversion kit 68 mm drill rod
- Programmable automatic lubrication system for Rock Drill
- HPR6030 Rock Drill 30 kW (40.2 hp)
- HPR6832 Rock Drill 32 kW (43 hp)
- CB radio
- Auxiliary air connections

For more complete information on Cat products, dealer services, and industry solutions, visit us on the web at www.cat.com

AEHQ6857-02 (03-2013)
Replaces AEHQ6857-01

© 2013 Caterpillar Inc.
All rights reserved

Materials and specifications are subject to change without notice. Featured machines in photos may include additional equipment. See your Cat dealer for available options.

CAT, CATERPILLAR, SAFETY.CAT.COM, their respective logos, "Caterpillar Yellow" and the "Power Edge" trade dress, as well as corporate and product identity used herein, are trademarks of Caterpillar and may not be used without permission.

