



Cat[®] SH660 D

ROOF SUPPORT CARRIER

Specifications

Capacities

Tractive Effort, Maximum	37 500 kg	82,673 lb
Winch (Front)	30 000 kg	66,138 lb
Maximum Un-braked Trailer Mass	23 000 kg	50,706 lb
Capacity of Tow Hitch	40 000 kg	88,184 lb
Lift SAE @ 600 mm (23.6 in) from Fork Face	55 000 kg	121,250 lb

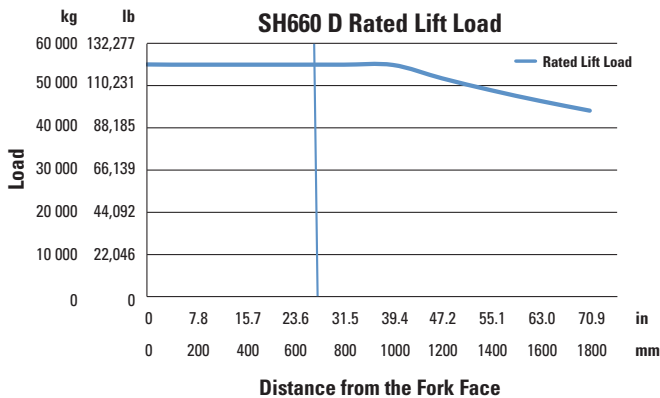

Weight

Unladen with Full Tanks	48 000 kg	105,821 lb
Maximum Laden	103 000 kg	227,076 lb

Engine (6 Cylinder)

Type	Diesel, Turbocharged	
Cooling System	Coolant Based Radiator	
Radiator Position	Horizontal Rear	
Cooling Fan	Hydraulic Driven Fan	
Engine Make/Model	Cat [®] C7	
Displacement	7.2 L	439.3 in ³
Maximum Power Gross	171.5 kW (230 hp) @ 2,200 rpm	
Maximum Torque Tested	895 N-m (660 lb-ft) @ 1,700 rpm	

Engine Speeds

Low Idle	800 rpm
High Idle	2,300 rpm

Fuel Consumption

At Full Power	39.4 L/hr	10.4 gal/hr
Average Mine Duty	20-40 L/hr	5.5-10.5 gal/hr

Exhaust Conditioner

Type	Flameproof Wet
Make	Caterpillar
Exhaust Filter	Replaceable Element Except China
Exhaust Flame Trap Aftertreatment	Replaceable China and RSA Catalytic Exhaust Purifier

Transmission

Speeds, Forward and Reverse	4
-----------------------------	---

Torque Converter

Type	Integral
------	----------

Axles

Front Axle	Heavy Duty Fixed
Rear Axle	Heavy Duty Bolster Mount

Wheels/Tires – Standard

Size	1371 mm O/D × 711 mm Wide (54 in O/D × 28 in Wide)
Inflation Media	Solid
Wheel Chains	Optional

Ground Pressure

Laden Front	1433 kPa	222 psi
Laden Rear	480 kPa	70 psi
Un-laden Front	450 kPa	65 psi
Un-laden Rear	800 kPa	116 psi

SH660 D Roof Support Carrier

Service Brake

Type	Totally Enclosed, Wet Type
Application	Spring Applied Hydraulic Released

Park Brake

Type	Totally Enclosed, Wet Type
Application	Spring Applied Hydraulic Released

Articulation

Degrees of Turn Either Side	45 Degree
-----------------------------	-----------

Oscillation

Degrees Up and Down from Horizontal	7.5 Degree
-------------------------------------	------------

Canopy

Type Protective Device	MDG1
Optional ROPS/FOPS	

Electrical System

Type	Approved Flameproof
Voltage	24V

Shutdown System

System Type	Cat DCS Electronic Intrinsically Safe Approved
-------------	---

Lights

Number/Location	STD 2 Front, 2 Rear
-----------------	---------------------

Service Capacities

Hydraulic Tank	510 L	134.7 gal
Fuel Tank	370 L	97.1 gal
Transmission/Converter Oil	40 L	10.6 gal
Drop Box Oil	8 L	2.1 gal
Engine Crankcase Oil	25 L	6.6 gal
Engine Cooling System Water	72 L	19.0 gal
Axle Oil (Each)	60 L	15.9 gal
Water Make Up Tank	450 L	118.9 gal

Rated Speed/Un-Laden/No Grade

1st Gear	2.6 km/h	1.6 mph
2nd Gear	6.3 km/h	3.9 mph
3rd Gear	11.1 km/h	6.9 mph
4th Gear	19.5 km/h	12.1 mph

Maximum Tractive Effort

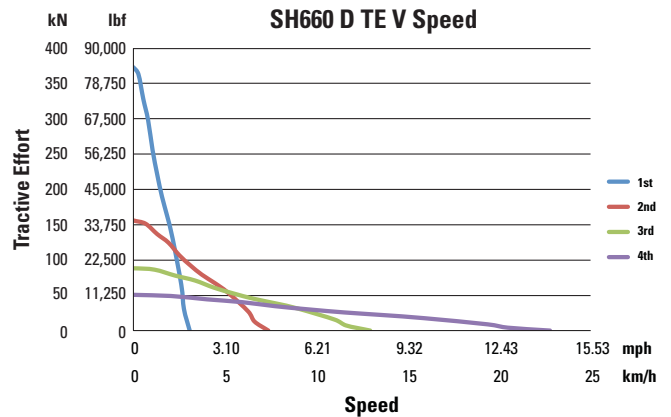

Grade Ability

Front to Rear	1:5
Side to Side (Empty)	1:4
Side to Side (Laden)	1:8

SH660 D Speed V Grade Laden

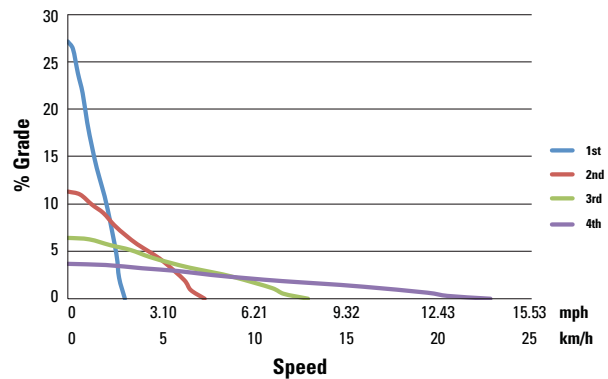

SH660 D Roof Support Carrier

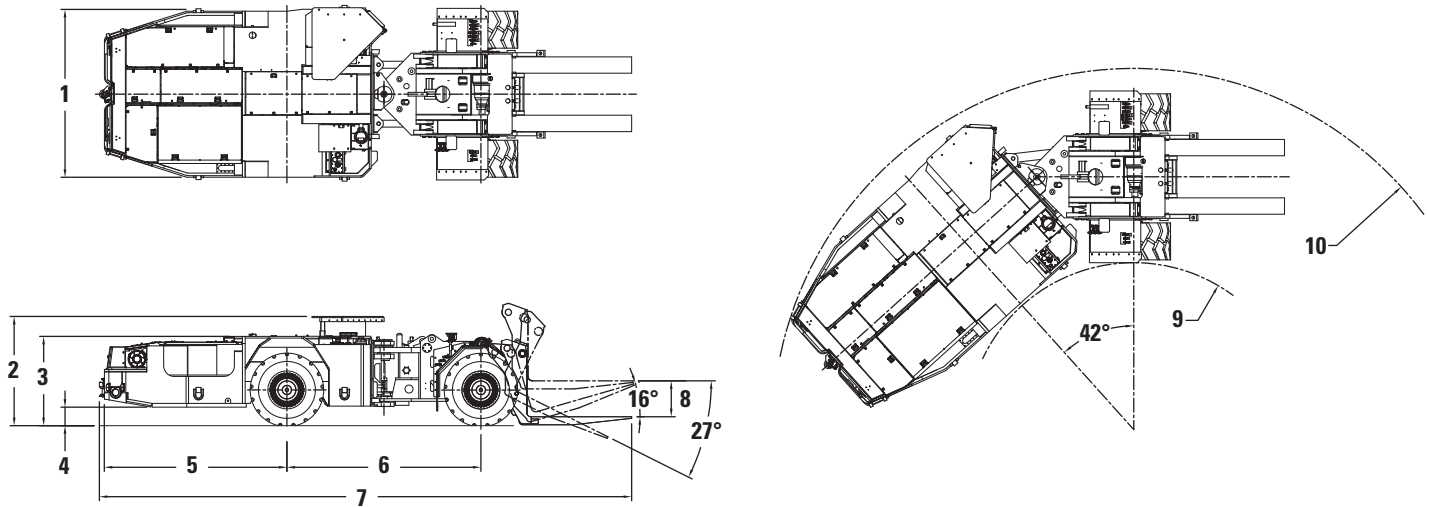

Dimensions (All dimensions are approximate.)

1 Width	3130 mm	129.1 in
2 Height – Top of ROPS		
LOW Canopy Mount	1980 mm	78.0 in
MID Canopy Mount	2050 mm	80.7 in
HIGH Canopy Mount	2120 mm	83.5 in
3 Height – Top of Covers	1670 mm	26.4 in
4 Height – Ground Clearance	340 mm	13.4 in
5 Length – Rear Axle to Bumper	3410 mm	134.3 in
6 Length – Wheel Base	3620 mm	142.5 in
7 Length – Overall	9940 mm	391.2 in
8 Lift Height of Fork	670 mm	26.7 in
9 Turning Radius – Inside Dimension	3120 mm	122.8 in
10 Turning Radius Outside Dimension	6740 mm	265.4 in

SH660 D Roof Support Carrier

OPTIONAL EQUIPMENT

- Load indication gauge system
- Cat 3126 DTI flame proof package
- Fire suppression systems
- ROPS/FOPS certified canopy
- Tow chains
- Wheel chains
- Alternative approved electrical components (lights, alternators, hour meters, etc.)
- Exhaust flame trap (optional) wet, standard for China, standard for RSA
- Auto lubrication system
- Chock carry plate
- Power assist trailer connection and fixed fifth wheel plate
- 12V electrical system STD 3126 DTI

For more complete information on Cat products, dealer services, and industry solutions, visit us on the web at www.cat.com

AEHQ6794 (10-12)

© 2012 Caterpillar
All Rights Reserved
Printed in U.S.A.

Materials and specifications are subject to change without notice. Featured machines in photos may include additional equipment. See your Cat dealer for available options.

CAT, CATERPILLAR, SAFETY.CAT.COM, their respective logos, "Caterpillar Yellow" and the "Power Edge" trade dress, as well as corporate and product identity used herein, are trademarks of Caterpillar and may not be used without permission.

