



# Cat<sup>®</sup> B Series Mulchers

Skid Steer Loaders  
Multi Terrain Loaders  
Compact Track Loaders

Cat<sup>®</sup> Mulchers are designed for high-performance cutting, and mulching vegetation and undergrowth from typical wooded terrain. The hydraulic mulcher reduces saplings, shrubs and trees into mulched material, making it ideal for environmental maintenance, such as creating fire lanes. Other applications include: reclaiming untilled land, removing foliage from building construction sites, and shredding pruned material and organic waste for biomass production.

#### Features:

##### Dual speed, axial piston hydraulic motor

- Dual speed, axial piston motor provides smooth, efficient performance while delivering optimal torque under changing material loads.

##### Rugged mulching head

- Rugged mulching head processes trees up to 200 mm (8 in) diameter for effective land clearing applications.

##### Single bolt retention, fixed tooth balanced rotor

- Fixed tooth balanced rotor provides excellent operating efficiency at high speed. Single bolt retention provides quick tooth replacement.

##### Adjustable push frame

- Adjustable push frame is standard equipment and provides the ability to position trees to allow for optimum cutting and efficiency. It also provides operator cab protection.

##### Max Pro Pressure Gauge

- Max Pro Pressure Gauge is standard equipment and provides operator feedback to adjust speed for maximum productivity in changing material loads.

##### Heavy-duty bearings

- Heavy-duty bearings extend work tool life.

##### Hydraulically operated front hood

- Hydraulically operated front hood is standard, allowing trees to be cut when opened and allows dense vegetation to be mulched.

##### Polychain belt drive

- Polychain belt provides abrasion resistance, shock load capability and protects against debris blockage.

##### Rear chain guard protection

- Rear chain guard protection reduces spread of material.

##### Rigid, robust tempered steel

- Rigid, robust tempered steel construction provides fully guarded protection in tough applications.

##### Cat XT<sup>™</sup>-3 ES hose, couplings and O-ring face seals

- Cat XT-3 ES hose, couplings and O-ring face seals provide superior, leak-free performance and reliability. All hoses are wrapped with nylon woven cordura sleeving for added operator protection. Hydraulic quick disconnects enable fast tool changes.

##### Quick coupler

- Rugged, opposing edge design holds the work tool securely and allows the operator to quickly change from one high performance Cat Work Tool to another.

# Cat B Series Mulchers

## Compatibility

Model	Machines
<b>HM315B*#</b>	246C, 256C, 262C/C2, 272C, 277C/C2, 279C/C2, 287C/C2, 289C/C2, 297C, 299C, 272D, 272D XHP, 299D, 299D XHP
<b>HM415B</b>	272D XHP, 299D XHP

\* Requires high flow XPS option on machine. Operates in high flow XPS on XHP machines.

# Requires a conversion kit for C Series and C Series 2 machines.

Debris Barrier package recommended.

## Specifications

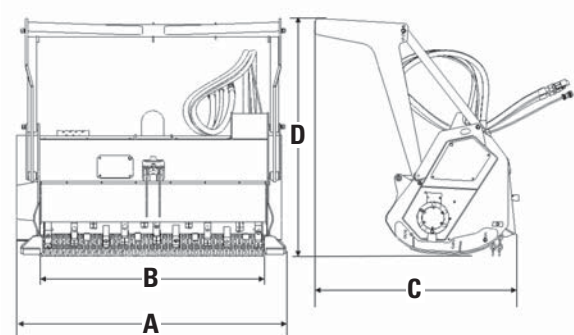

		<b>HM315B</b>		<b>HM415B</b>	
<b>A</b> Overall width	mm (in)	1840	(72)	1840	(72)
<b>B</b> Working width	mm (in)	1465	(58)	1465	(58)
<b>C</b> Length	mm (in)	1470	(58)	1470	(58)
<b>D</b> Overall height	mm (in)	1610	(63)	1610	(63)
Weight	kg (lb)	1165	(2,564)	1165	(2,564)
Drive method		Polychain belt		Polychain belt	
Motor		Dual speed Axial piston		Dual speed Axial piston	
Optimum hydraulic flow range	L/min (gpm)	120-137	(31.5-36)	133-155	(36-41)
Optimal hydraulic pressure range	bar (psi)	195-350	(2,828-5,075)	195-350	(2,828-5,075)
Drum speed range	rpm	2,100-2,400		1,900-2,200	
Fixed teeth per drum		34		34	
Maximum cutting diameter	mm (in)	200	(8)	200	(8)

For more complete information on Cat products, dealer services, and industry solutions, visit us on the web at [www.cat.com](http://www.cat.com)

AEHQ6787 (05-12)

© 2012 Caterpillar  
All Rights Reserved  
Printed in U.S.A.

Materials and specifications are subject to change without notice. Featured machines in photos may include additional equipment. See your Cat dealer for available options.

CAT, CATERPILLAR, SAFETY.CAT.COM, their respective logos, "Caterpillar Yellow" and the "Power Edge" trade dress, as well as corporate and product identity used herein, are trademarks of Caterpillar and may not be used without permission.

