

# 305.5E CR Mini Hydraulic Excavator

## 305.5E CR Dimensions

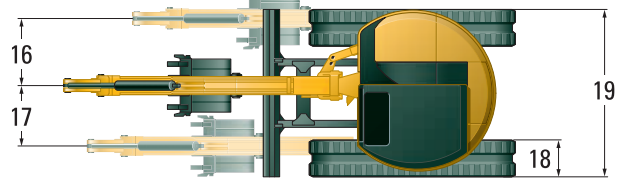
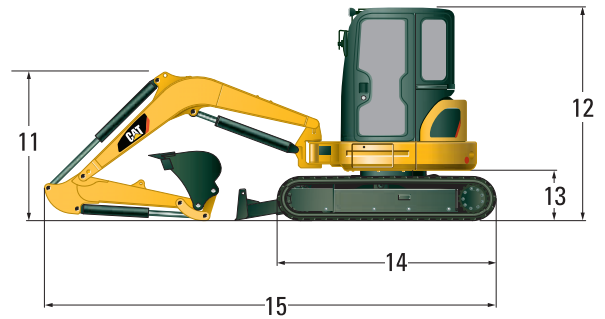
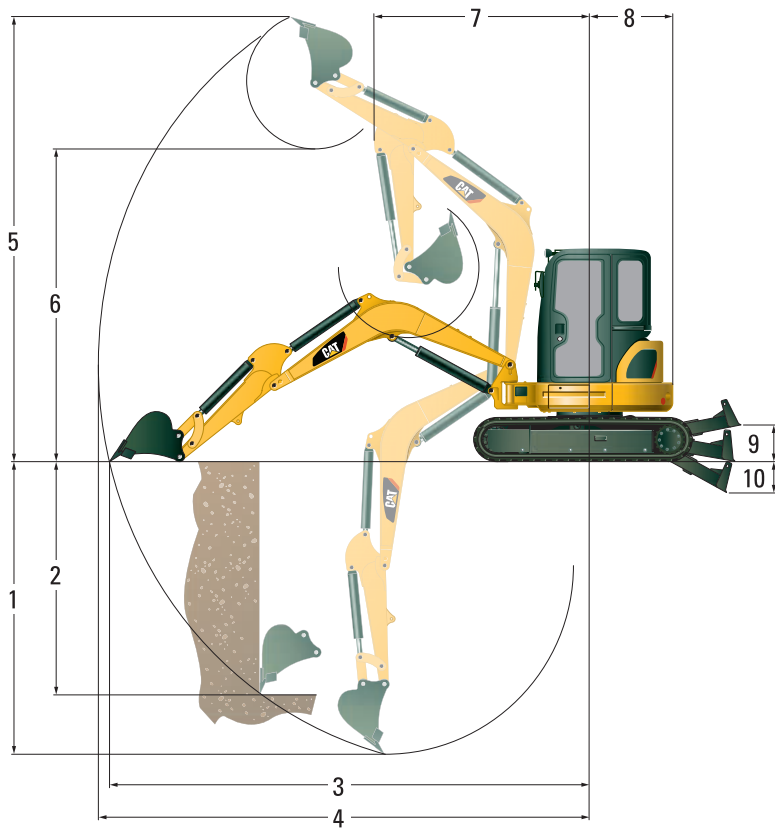

	Standard Stick		Long Stick	
<b>1</b>	3470 mm	11'4"	3870 mm	12'8"
<b>2</b>	2330 mm	7'8"	2730 mm	9'0"
<b>3</b>	5630 mm	18'6"	6020 mm	19'9"
<b>4</b>	5790 mm	19'0"	6170 mm	20'3"
<b>5</b>	5330 mm	17'6"	5590 mm	18'4"
<b>6</b>	3820 mm	12'7"	4080 mm	13'4"
<b>7</b>	2400 mm	7'10"	2530 mm	8'3"
<b>8</b>	1130 mm	3'8"	1130 mm	3'8"
<b>9</b>	405 mm	1'4"	405 mm	1'4"
<b>10</b>	555 mm	1'10"	555 mm	1'10"

	Standard Stick		Long Stick	
<b>11</b>	1740 mm	5'8"	2150 mm	6'11"
<b>12</b>	2550 mm	8'4"	2550 mm	8'4"
<b>13</b>	615 mm	2'0"	615 mm	2'0"
<b>14</b>	2580 mm	8'6"	2580 mm	8'6"
<b>15</b>	5330 mm	17'6"	5460 mm	17'10"
<b>16</b>	785 mm	2'7"	785 mm	2'7"
<b>17</b>	695 mm	2'3"	695 mm	2'3"
<b>18</b>	400 mm	1'4"	400 mm	1'4"
<b>19</b>	1980 mm	6'6"	1980 mm	6'6"

## 305.5E CR Lift Capacities at Ground Level\*

Lift Point Radius		3000 mm (9'8")		4500 mm (14'9")	
		Front	Side	Front	Side
Blade Down	<b>kg</b>	2590	1290	1380	690
	<b>lb</b>	5,710	2,844	3,042	1,521
Blade Up	<b>kg</b>	1550	1150	820	620
	<b>lb</b>	3,417	2,535	1,808	1,367

\* The above loads are in compliance with hydraulic excavator lift capacity rating standard ISO 10567:2007 and they do not exceed 87% of hydraulic lifting capacity or 75% of tipping capacity. The excavator bucket weight is not included on this chart. Lifting capacities are for standard stick.