

988H/990H

Wheel Loaders
Steel Mill Arrangement



Engine – 988H

Engine Model	Cat® C18 ACERT™	
Net Power – ISO 9249	373 kW	501 hp

Weights – 988H

Operating Weight	58 330 kg	128,328 lb
------------------	-----------	------------

Engine – 990H

Engine Model	Cat® C27 ACERT™	
Net Power – ISO 9249	468 kW	627 hp

Weights – 990H

Operating Weight	78 127 kg	172,270 lb
------------------	-----------	------------

Weights – 990H SMASH

Operating Weight	89 963 kg	190,640 lb
------------------	-----------	------------

Steel Mill Arrangement Features

Reliability

Cat® Large Wheel Loaders offer field proven components and systems, high hour machine life standards and multiple rebuild options for continued uptime and long machine life.

Steel Mill Specific Features

Purpose build guarding and insulation is designed to protect machine systems from the extreme heat and harsh environment of the steel mill application.

Serviceability

Easy access to the engine and other key serviceability features make servicing customer machines and in-field component exchange quick, easy, and efficient.

Safety

Caterpillar continues to be proactive in developing machines that meet or exceed safety standards. Safety is an integral part of all machines and system designs, and can be seen throughout the wheel loaders models.

Productivity

Productivity is critical to your bottom line. Cat large wheel loaders offer features and systems that help improve performance and lower your operating costs.

Operator Comfort

From low effort controls to reduced operator sound, Cat wheel loaders have a number of features that minimize operator fatigue, resulting in a safe, productive work site.

Contents

Reliability	3
Steel Mill Specific Features	4
Productivity	5
Operator Comfort	6
Serviceability	7
Safety	8
Steel Mill Arrangement Specifications	9
Notes	13



In the harsh environment of a steel mill application, you need a wheel loader designed for the job. That is why all Cat® Wheel Loaders are purpose-built with standard and optional guarding on major components and systems. Read on to learn more about how these steel mill wheel loaders deliver sustainable productivity, fuel efficiency, serviceability, ergonomics and operator comfort.

Reliability

Maximizing uptime, long life – its what you expect from your Cat Wheel Loader.

Structures

Combining the use of robotic welding and castings in critical high stress areas, more than 80 percent of Cat® Large Wheel Loader structures are robotically welded to provide highly consistent welds and increased strength. Castings are also used in several areas to increase strength by helping spread the loads and reduce the number of parts.

Front Frame and Rear Frame

Highly engineered and a field proven combination, Cat® Large Wheel Loaders use high strength plates and castings which distribute loads and increase structural robustness. A key differentiator from other manufactures machines is the box section rear frame and box section loader tower. The box section absorbs tensional forces generated in a loading cycle, maintaining alignment for hitch pins and driveline. The box shaped loader tower resists shock and torsional loads, maintaining hitch and loader linkage pin alignment, maximizing pin life.

Axle-Shaft, Oil Disc Brakes

These brakes are adjustment free, fully hydraulic and completely sealed. Disc face grooves provide cooling even when brakes are applied for a longer component life.

- Location of brakes allow for improved serviceability. The axle shaft brake design allows for brake service while leaving the final drive intact.
- Axle-shaft brakes require less force by operating on the low torque side of the axle. Combined with improved axle oil circulation for increased cooling, the oil-enclosed, multiple disc brake design improves durability.

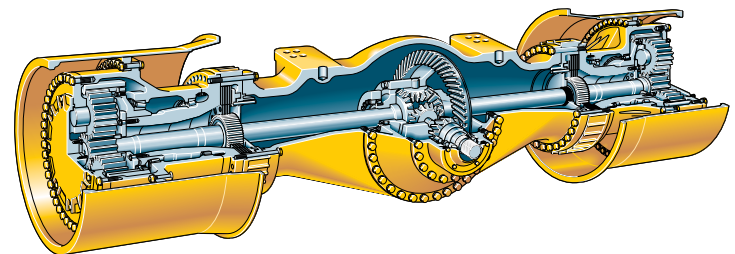
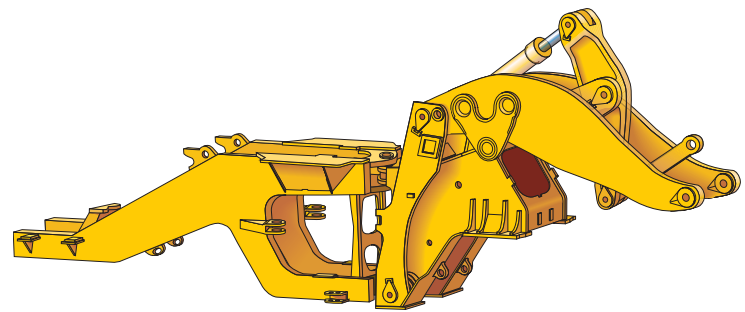

Steel Mill Specific Features

Safeguarding the operator and critical machine components.



Operator Station

Steel roof and cab skirts provide additional protection from heat and debris.

Transmission Override

A transmission override control in the cab allows the operator a secondary transmission control in the event of damage to transmission Electronic Control Module (ECM). The operator can select 1F or 1R to move the machine to a safe area for repairs to be made.

Machine Guarding

Front frame bottom guard and steering cylinder guards protect sensitive machine components from the effects of hot materials.

Solid metal steps, profiled bumper guards and solid metal handrails are designed to survive tight working spaces.

Hydraulic and Electrical System

All exposed wiring harnesses and hydraulic hoses are insulated with protective sleeving to protect from extreme heat.

Guarding on fuel and hydraulic tanks provides protection from puncture and excessive heat.

Optional EcoSafe Hydraulic Fluid

Fire resistant EcoSafe hydraulic fluid is available from the factory and is fully compatible with Caterpillar hydraulic system components.

Extreme Temperature Axle Seals

Caterpillar extreme temperature axle seals provide excellent sealing characteristics and life in the extreme heat of the still mill application.

Parking Brake Override

The parking brake override control, located at the rear of the bumper, allows the parking brake to be disabled with the engine not running.



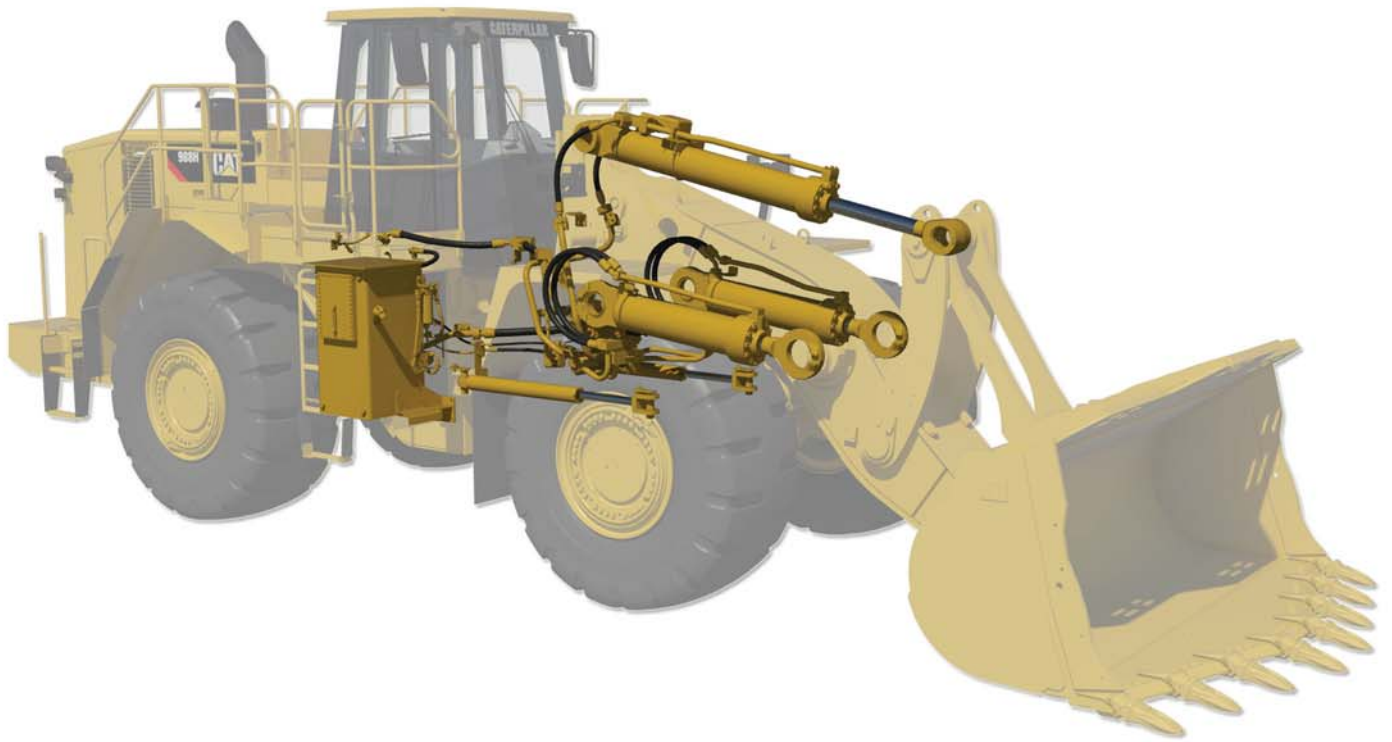

Productivity

Designed with the right features to meet the daily demands of your job site.

Both the 988H and 990H features are specifically designed to increase productivity on your job site.

Engine

The Cat® C18 and C27 engine with ACERT™ Technology are U.S. EPA Tier 3 and EU Stage III compliant. They feature increased horsepower and efficient fuel management for quick response, high productivity and exceptional service life. A sculptured cylinder block provides greater strength and is lighter weight.

Positive Flow Control Hydraulics (988H only)

The 988H Positive Flow Control (PFC) Hydraulic System is setting a new standard for hydraulic response, performance and efficiency. The implement system is equipped with one electronically controlled, fully variable piston pump for fast, productive cycles. PFC has concurrent pump and valve control. This is achieved through an integrated solenoid with a force feedback system which keeps the displacement where it is required for optimized pump control. By optimizing pump control, hydraulic oil flow is proportionate to implement lever stroke.

Benefits:

- Lowered fuel consumption by up to five percent
- Improved hydraulic response, giving the operator better feel and control of the bucket
- Improved power efficiency and lower system heat

Steel Mill Arrangement Skull Handler (SMASH) (990H only)

The 990H SMASH arrangement provides unique lift and tilt cylinders and added counterweight to produce the lift and breakout forces necessary to handle heavy skulls.



Operator Comfort

Best-in-class working environment

Best-in-Class Working Environment

A comfortable operator is a productive operator, which is why Caterpillar has designed the 988H and 990H with a best in-class working environment for this size wheel loader class.

- World class cabs incorporate features for operator comfort and ergonomics, visibility and ease of operation.
- Ergonomic controls are fully adjustable and designed for low-effort comfort. Switches and controls for various systems are located within easy reach of the operator.
- Interior noise levels are reduced to a quiet 72 dB(A).
- Caterpillar Monitoring System (EMS-III) provides information on machine's major components.

This includes gauge displays for the fuel tank level; temperature gauges for the engine coolant, torque converter and hydraulic oil; tachometer analog gauge with digital readout for gear selection and ground speed and a monitoring system.

- New options to include heated seat for cold weather operations and radio offerings of Bluetooth, MPS and satellite options are now available.

Serviceability

Easy to Maintain. Easy to Service.

Optional Swing Out Radiator Fan (988H only)

The optional swing out radiator fan provides for easy access to the radiator cores for easy cleaning and inspection.

Optional Auto Reversing, Hydraulically Driven Demand Fan (988H only)

The demand fan automatically adjusts fan speed for optimal cooling, resulting in reduced power draw on the engine, better fuel efficiency and more power for hydraulics and rimpull. The fan reverses automatically at preset intervals to remove debris from the inlet screen. It can also be reversed manually from the cab.

Component Access

Swing out doors on both sides of the engine compartment provide easy access to the engine oil dipstick and filler spout, S·O·SSM ports, fuel filters air conditioner compressor, engine oil filters, alternators, starting receptacle, air filter service indicator, cooler fill and ether starting aid. There are also ground level viewable sight gauges on all major systems and centralized remote pressure taps.

Shutdown and Lockout Features

An electrical disconnect switch and hydraulic lockout switch allow service technicians to perform maintenance while the machine stays static. Other shutdown or lockout devices include ground level engine shutdown and ground level steering hitch lock lever.





Safety

Built to Protect You

Entry and Exit

Getting on and off the machine is one of the leading causes of injury on a job site. Cat® Wheel Loaders have a number of features to ensure your operator gets safely on and off the machine. Features include primary and secondary stairwell exits, punch stamped tread plates, ground level nighttime stairwell light switch, full perimeter railings on upper platforms, side platform emergency egress and toe kicks and optional roading fenders.

Rearview Camera

With the new optional rearview camera, visibility is greatly enhanced. The camera is located in a pocket on the grill to protect it from damage and the elements. The camera can be set to activate only when the transmission is in reverse to help eliminate distractions in the cab, especially when in dark environments.

Visibility

Cat® Wheel Loaders offer a number of standard and optional features to enhance job site visibility. Standard and optional features include long life LED lights, articulated wiper/washer system with intermittent features, optional rear vision camera, optional high intensity discharge lights, optional warning beacon and optional turn signals.

Steel Mill Arrangement Specifications

Operating Specifications – 988H

Attachment Type	9 yd ³ Rock Bucket	
Hinge Pin Height, Unloaded	4909 mm	16.11 ft
Overall Length	12 410 mm	40.75 ft
Turning Radius at SAE Carry	8762 mm	28.75 ft
Tipping Load:		
Straight	33 861 kg	74,651 lb
Articulated 43°	30 210 kg	66,602 lb
Operating Weight	58 330 kg	128,328 lb
Breakout Force – SAE Rated (3.88 m linkage)	49 062 kg	45,977 lb
Breakout Force – SAE Rated (4.25 m linkage)	52 971 kg	116,780 lb

Engine – 988H

Engine Model	Cat® C18 ACERT™	
Gross Power	414 kW	555 hp
Net Power – ISO 14396	393 kW	532 hp
Net Power – EEC 80/1269	373 kW	501 hp
Net Power – ISO 9249	373 kW	501 hp
Gross Power – ISO 3046-2	388 kW	520 hp
Bore	145 mm	5.7 in
Stroke	183 mm	7.2 in
Displacement	18.1 L	1,104.5 in ³

Loader Hydraulic System – 988H

Main Hydraulic System Output at 2,010 rpm and 6900 kPa (1,000 psi)	492 L/min	130 gal/min
Relief Valve Setting	35 000 kPa	5,075 psi
Cylinders, Double Acting: Lift, Bore and Stroke	220 × 911 mm	8.7 × 35.9 in
Cylinders, Double Acting: Tilt, Bore and Stroke	220 × 1770 mm	8.7 × 69.7 in
Pilot System, Gear-Type Pump Output at 2,010 rpm and 2500 kPa (363 psi)	76 L/min	20.1 gal/min
Relief Valve Setting (low idle)	2400 kPa	348.1 psi

- With SAE 10W oil at 66° C (150° F).

Transmission – 988H

Converter Drive – Forward 1	6.7 km/h	4.2 mph
Converter Drive – Forward 2	11.8 km/h	7.3 mph
Converter Drive – Forward 3	20.8 km/h	12.9 mph
Converter Drive – Forward 4	36 km/h	22.3 mph
Converter Drive – Reverse 1	7.6 km/h	4.7 mph
Converter Drive – Reverse 2	13.5 km/h	8.4 mph
Converter Drive – Reverse 3	23.7 km/h	14.7 mph
Direct Drive – Forward 1	Lock-up disabled	
Direct Drive – Forward 2	12.3 km/h	7.7 mph
Direct Drive – Forward 3	21.9 km/h	13.6 mph
Direct Drive – Forward 4	38.6 km/h	24 mph
Direct Drive – Reverse 1	7.9 km/h	4.9 mph
Direct Drive – Reverse 2	14.1 km/h	8.8 mph
Direct Drive – Reverse 3	25.1 km/h	15.6 mph

Axles – 988H

Maximum Single – Wheel Rise and Fall	568 mm	22.4 in
Front	Fixed	
Rear	Oscillating ±13°	

Brakes

Brakes	Meet SAE/ISO 3450:1996
--------	------------------------

Steering – 988H

Steering	Meets SAE and ISO standards
Total Steering Angle	74 Degrees

Cab

Cab – ROPS/FOPS	Meets SAE and ISO standards
Sound Performance	Meets ANSI, SAE and ISO standards

Service Refill Capacities – 988H

Fuel Tank	712 L	188 gal
Cooling System	103 L	27.2 gal
Crankcase	60 L	15.9 gal
Transmission	70 L	18.5 gal
Differentials and Final Drives – Front	186 L	49 gal
Differentials and Final Drives – Rear	186 L	49 gal
Hydraulic System (factory fill)	470 L	124.2 gal
Hydraulic System (tank only)	267 L	70.5 gal

Steel Mill Arrangement Specifications

Operating Specifications – 990H

Attachment Type	12 yd ³ Rock Bucket	
Hinge Pin Height, Unloaded	5866 mm	19.25 ft
Overall Length	12 905 mm	42.1 ft
Turning Radius at SAE Carry	10 342 mm	33.9 ft
Tipping Load:		
Straight	45 923 kg	101,260 lb
Articulated 43°	41 105 kg	90,637 lb
Operating Weight	78 127 kg	172,270 lb
Breakout Force – SAE Rated	61 430 kg	135,429 lb
Tipping Load (990H SMASH):		
Straight	67 485 kg	148,779 lb
Articulated 43°	55 949 kg	123,347 lb
Operating Weight (990H SMASH)	89 963 kg	190,640 lb
Breakout Force (990H SMASH) – SAE Rated	73 663 kg	162,400 lb

Engine – 990H

Engine Model	Cat® C27 ACERT™	
Gross Power	512 kW	687 hp
Flywheel Power	468 kW	627 hp
Net Power – EEC 80/1269	468 kW	627 hp
Net Power – ISO 9249	468 kW	627 hp
Gross Power – ISO 3046-2	468 kW	627 hp
Bore	137 mm	5.4 in
Stroke	152 mm	6 in
Displacement	27.1 L	1,666 in ³

Loader Hydraulic System – 990H SMASH

Main Hydraulic System Output at 2,128 rpm and 6900 kPa (1,000 psi)	650 L/min	172 gal/min
Relief Valve Setting	31 000 kPa	4,500 psi
Cylinders, Double Acting: Lift, Bore and Stroke	254 mm × 1264 mm	10 in × 49.75 in
Cylinders, Double Acting: Tilt, Bore and Stroke	317.5 mm × 819 mm	12.5 in × 32.2 in
Pilot System, Gear-Type Pump Output at 2,000 rpm and 6900 kPa (1,000 psi)	46 L/min	12 gal/min
Relief Valve Setting (low idle)	2400 kPa	350 psi

Transmission – 990H

Converter Drive – Forward 1	7 km/h	4.3 mph
Converter Drive – Forward 2	12.1 km/h	7.5 mph
Converter Drive – Forward 3	20.8 km/h	12.9 mph
Converter Drive – Reverse 1	7.7 km/h	4.8 mph
Converter Drive – Reverse 2	13.4 km/h	8.3 mph
Converter Drive – Reverse 3	22.8 km/h	14.2 mph
Direct Drive – Forward 1	Lock-up disabled	
Direct Drive – Forward 2	12.8 km/h	7.9 mph
Direct Drive – Forward 3	22.4 km/h	13.9 mph
Direct Drive – Reverse 1	7.9 km/h	4.9 mph
Direct Drive – Reverse 2	14.1 km/h	8.8 mph
Direct Drive – Reverse 3	24.8 km/h	15.4 mph

Axles – 990H

Maximum Single – Wheel Rise and Fall	572 mm	22.5 in
Front	Fixed	
Rear	Oscillating	
Oscillation Angle	±11°	

Brakes

Brakes	Meet SAE/ISO 3450:1996
--------	------------------------

Steering – 990H

Steering	Meets SAE and ISO standards
Total Steering Angle	70 Degrees

Cab

Cab – ROPS/FOPS	Meets SAE and ISO standards
Sound Performance	Meets ANSI, SAE and ISO standards

Service Refill Capacities – 990H

Fuel Tank	1074 L	284 gal
Cooling System	190 L	50.2 gal
Crankcase	95 L	25 gal
Transmission	110 L	29 gal
Differentials and Final Drives – Front	271 L	71.6 gal
Differentials and Final Drives – Rear	261 L	68.9 gal
Hydraulic System (tank only)	174 L	45.97 gal
Hydraulic System – Lift/Tilt and Brakes	435 L	113 gal
Hydraulic System – Steering and Engine Cooling Fan	194 L	50.5 gal
Hydraulic System (including tank)	435 L	114.91 gal

Dimensions – 988H

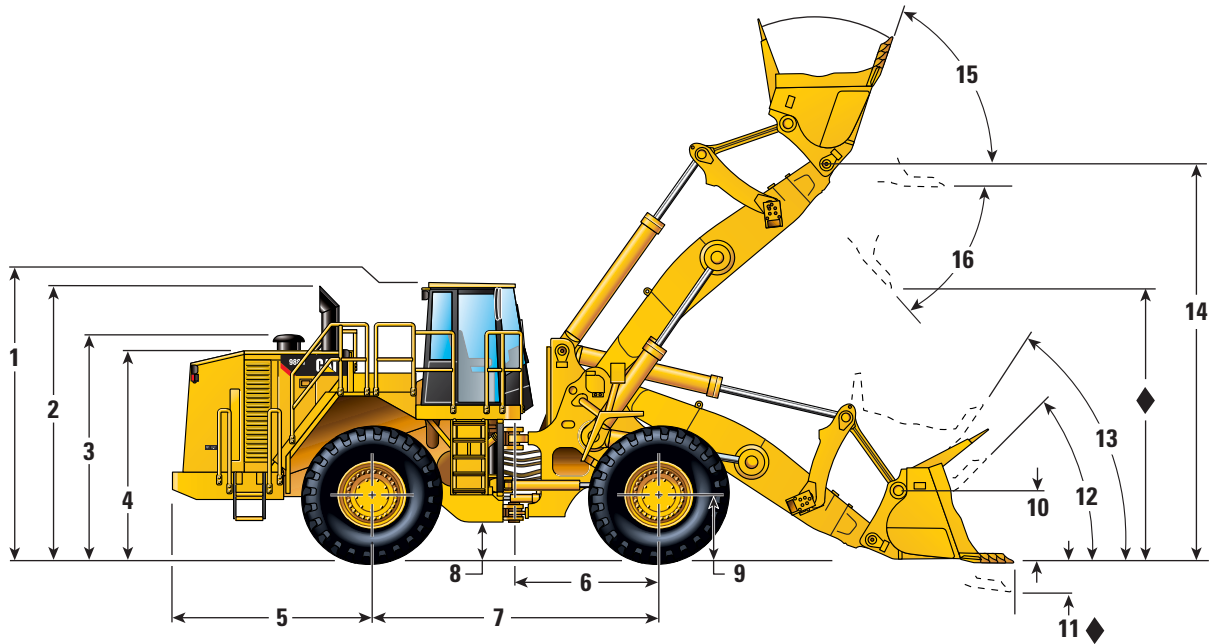

4.25 Meter Linkage

◆ Dimensions vary with bucket. Refer to Operation/Bucket Specifications.

1 Height to Top of Cab	4105 mm	13.47 ft
2 Height to Top of Exhaust Stacks	4089 mm	13.42 ft
3 Height to Top of Air Cleaner	3359 mm	11.02 ft
4 Height to Top of Hood	3133 mm	10.28 ft
5 Center Line of Rear Axle to Edge of Rear Bumper	3132 mm	10.28 ft
6 Center Line of Front Axle to Hitch	2275 mm	7.46 ft
7 Wheel Base Length	4550 mm	14.93 ft
8 Ground Clearance	526 mm	1.73 ft
9 Height to Center of Wheel	955 mm	3.13 ft
10 C-Pin Height**	1157 mm	3.8 ft
11 Dig Depth	264 mm 232 mm*	10 in 9 in*
12 Rack Back Angle at Ground		47.8° 45.7°*
13 Rack Back Angle at Carry		58.7° 54.5°*
14 B-Pin Height	5830 mm 5417 mm*	19.13 ft 17.77 ft*
15 Rack Back Angle at Maximum Lift		73°
16 Dump Angle at Maximum Lift		48.5° 51.4°*

*3.88 Meter Linkage

**Same for both 3.88 and 4.25 Meter Linkage

Steel Mill Arrangement Specifications

Dimensions – 990H

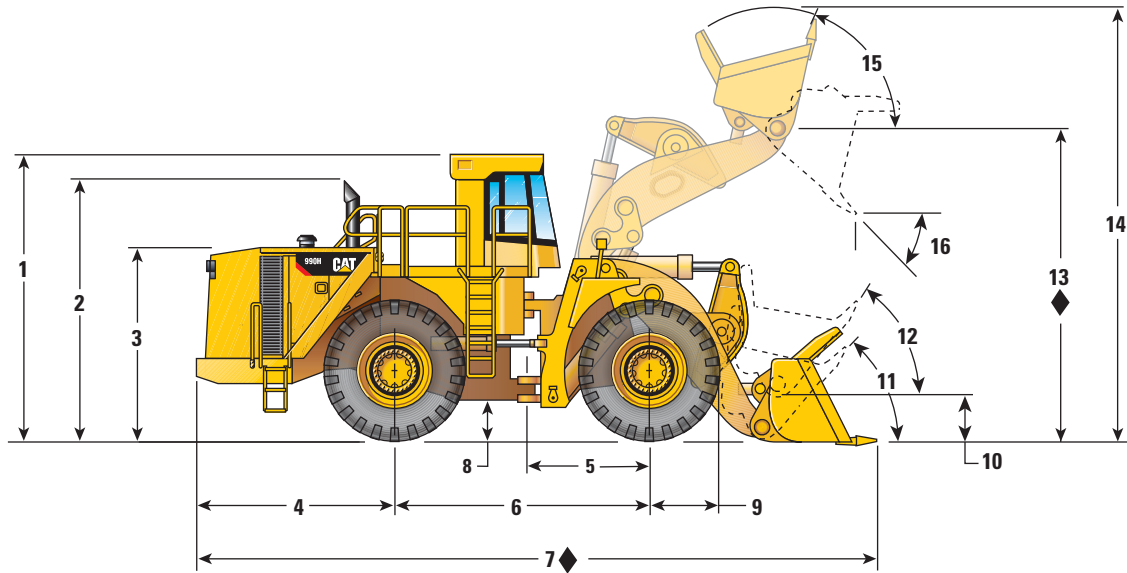

◆ Dimensions vary with bucket. Refer to Operation/Bucket Specifications.

1 Height to Top of Cab	5070 mm	16 ft 8 in
2 Height to Top of Exhaust Stacks	4726 mm	15 ft 6 in
3 Height to Top of Hood	3515 mm	11 ft 6 in
4 Center Line of Rear Axle to Edge of Rear Bumper	3615 mm	11 ft 10 in
5 Center Line of Front Axle to Hitch	2300 mm	7 ft 7 in
6 Wheel Base Length	4600 mm	15 ft 1 in
7 Length with Bucket on Ground		
8 Ground Clearance	478 mm	19 in
9 Height to Center of Wheel	1261 mm	4 ft 2 in
10 C-Pin Height** – Carry Height		
High Lift	1019 mm	3 ft 4 in
Standard	775 mm	2 ft 7 in
11 Rack Back Angle at Ground		39.1°
12 Rack Back Angle at Carry		48.4°
13 B-Pin Height		
High Lift	6432 mm	21 ft 1 in
Standard	5866 mm	19 ft 3 in
14 Overall Height with Bucket Raised		
High Lift	8638 mm	28 ft 4 in
Standard	8072 mm	26 ft 6 in
15 Rack Back Angle at Maximum Lift		64°
16 Dump Angle at Maximum Lift		45°

Steel Mill Arrangement

For more complete information on Cat products, dealer services, and industry solutions, visit us on the web at www.cat.com

© 2012 Caterpillar Inc.
All rights reserved

Materials and specifications are subject to change without notice. Featured machines in photos may include additional equipment. See your Cat dealer for available options.

CAT, CATERPILLAR, SAFETY.CAT.COM, their respective logos, "Caterpillar Yellow" and the "Power Edge" trade dress, as well as corporate and product identity used herein, are trademarks of Caterpillar and may not be used without permission.

AEHQ6460 (02-2012)

