

# AS4252C

Vibratory and  
Tamper Bar Screed



<b>AS4252C Screed Weight</b>	<b>3200 kg</b>	<b>7,055 lb</b>
<b>Paving Ranges</b>		
Hydraulically extendable	2.55 m - 5.0 m	8' 4" - 16' 4"
Maximum w/bolt-on extensions	2.55 m - 8.0 m	8' 4" - 26' 4"
Bolt-on extension widths	0.25 m	10"
	0.75 m	30"

# TOP PERFORMANCE

Top performing screeds combine operator-friendly controls, quick adjustments and reliable screed plate heating in order to deliver smooth, high-quality mats.

The AS4252C screed offers variable frequency tamper bars, vibratory screed plates, double-width extenders, LCD operating display, and electric heat for high performance on all types of mix designs and job sites including interstates, highways, airports.

The adjustable speed tamper bars ensure smooth flow under the screed plates, while the vibratory system provides additional compaction for optimal mat quality.

The double-width extenders maximize job site versatility by delivering a wide paving range to meet application requirements.

An intuitive LCD display keeps the operator informed of screed plate temperature, tamper bar speed, vibratory speed, and screed counter-balance pressure.

The easy-to-use electric screed heat system quickly gets the plates and tamper bars up to the ideal operating temperature for fast starts.

The CANbus electrical system, color-coded and numbered electrical wiring, sealed and soldered connections, and O-ring face seal fittings ensure top performance and long term reliability.

## CONTENTS

Screed Overview . . . . .	4,5
High Density Features . . . . .	6
Operating Controls . . . . .	7
Cat® Grade and Slope . . . . .	8,9
Electric Screed Heat . . . . .	10
Paving Range. . . . .	11
Specifications . . . . .	11

## HIGH DENSITY SCREED

- Tamper-bars and vibratory screed plates maximize mat density
- Double extending design with extensions deliver a wide paving range of 2.55 m - 8.0 m (8' 4" - 26' 4")
- Tamper bar heating elements and optional heated end gates optimize flow
- Low profile frame offers good visibility into the auger chamber
- Foldable end gates (option) reduce overall width for easier transport

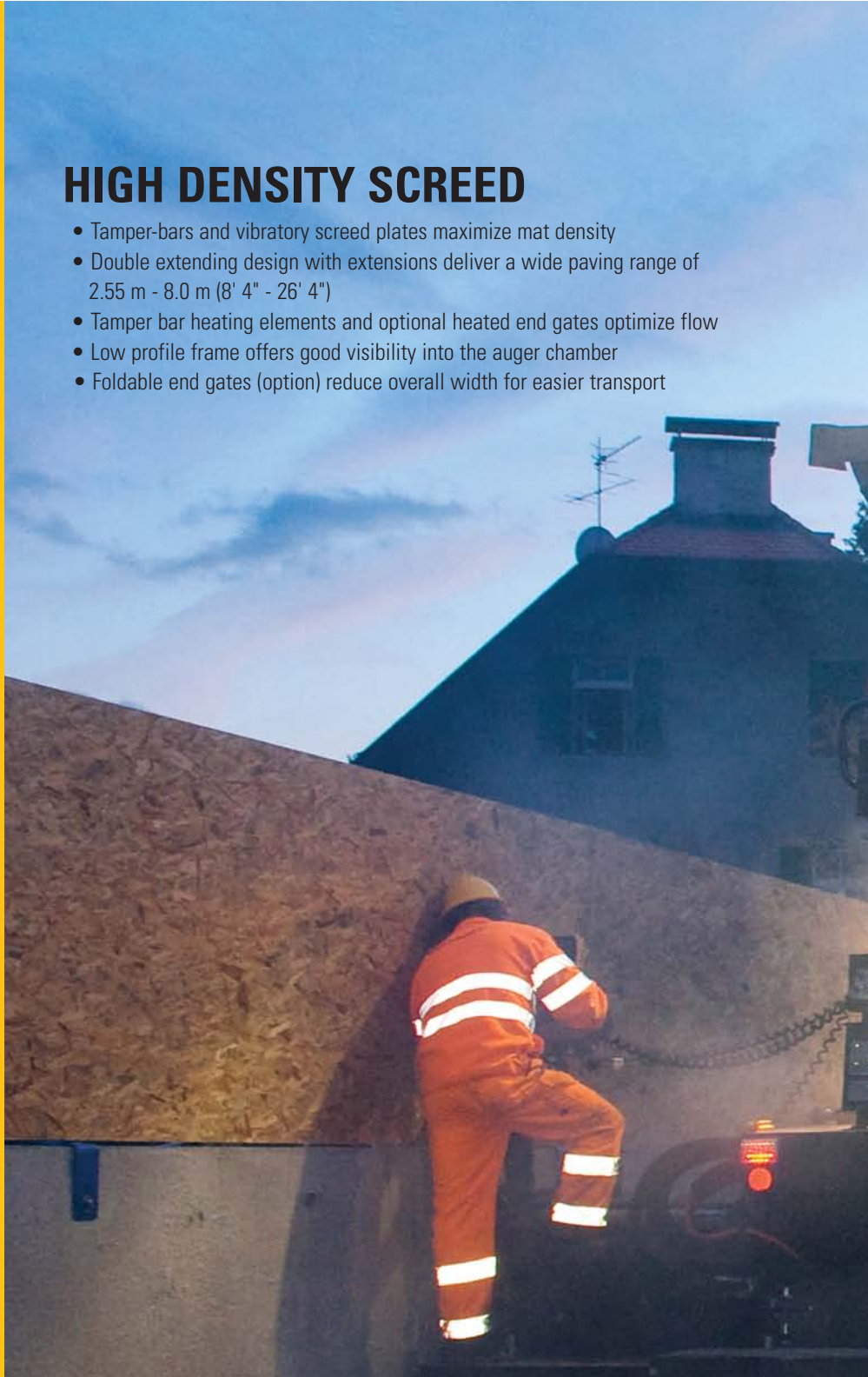

## ADVANCED SCREED CONTROL

- LCD display keeps operator informed
- Main screed controls are ergonomically located and move with the extenders to optimize operator efficiency
- Positive feedback switches make adjustments easy – operator can simply locate switches while monitoring surrounding environment
- Control panels optimize spacing so the operator can easily operate with work gloves
- Mix height dial easily maintains the head of material when varying paving widths
- Standard power control for crown simplifies setup

## LEADING-EDGE TECHNOLOGY

- LCD display keeps crew informed of screed plate temperatures as well as tamper bar and vibratory settings
- CANbus electrical system; reduces wiring, more reliable, easier diagnostics
- Integrated Cat® Grade and Slope Automation offers plug and play capability; more precise control, and a visual display with multiple language options

## EXCELLENT SERVICE AND RELIABILITY

- Electronic Control Module (ECM) is compatible with Cat ET for fast and easy diagnostics
- Durable, positive feedback switches withstand rigorous utilization
- Easy component access simplifies routine service
- Well-designed hydraulic routings are protected with kevlar braid
- Color-coded electrical wiring simplifies troubleshooting procedures
- O-ring face seals (ORFS) offer durability and prevent leaks

## FAST HEATING ELECTRIC SCREED

- New high efficiency heating system delivers quick heat up and even distribution to standard and wide width paving packages - leads to faster project start times
- User-friendly touch pad technology simplifies operation
- Independent temperature control, includes temperature sensors in each screed section, including extensions
- Three pre-set temperature settings for each screed section
- Manual override capability
- Heated tamper bars ensures smooth flow under the screed
- Heated end gates (option) minimize build-up and improve mix flow

# TAMPER BARS AND VIBRATORY SCREED PLATES MAXIMIZE DENSITY BEHIND THE SCREED.

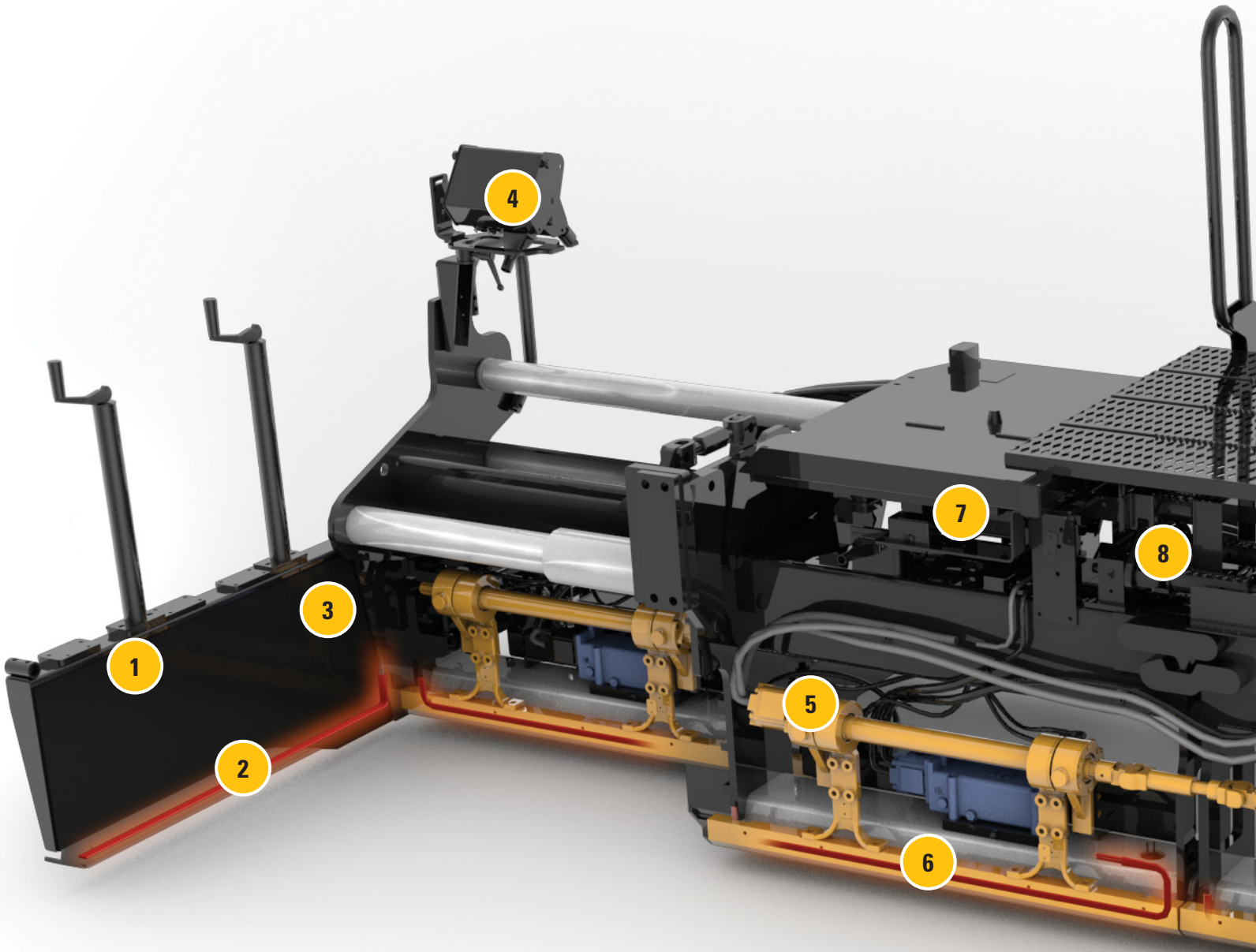

1. Spring-Loaded End Gates
2. Heated End Gate (option)
3. Foldable End Gates (option)
4. Main Screed Controls
5. Tamper Bar Eccentric Drive
6. Tamper Bar Heating Element
7. CANbus Electrical System
8. Standard Power Crown
9. Color-coded Electrical Wiring
10. Vibratory Drive (Variable Speed)
11. Electric Heat Control Panel
12. LCD Operating Display
13. Double Width Extenders
14. Tamper Bar
15. Wear Plate
16. Screed Plate Heating Element
17. Single Main Screed Plate

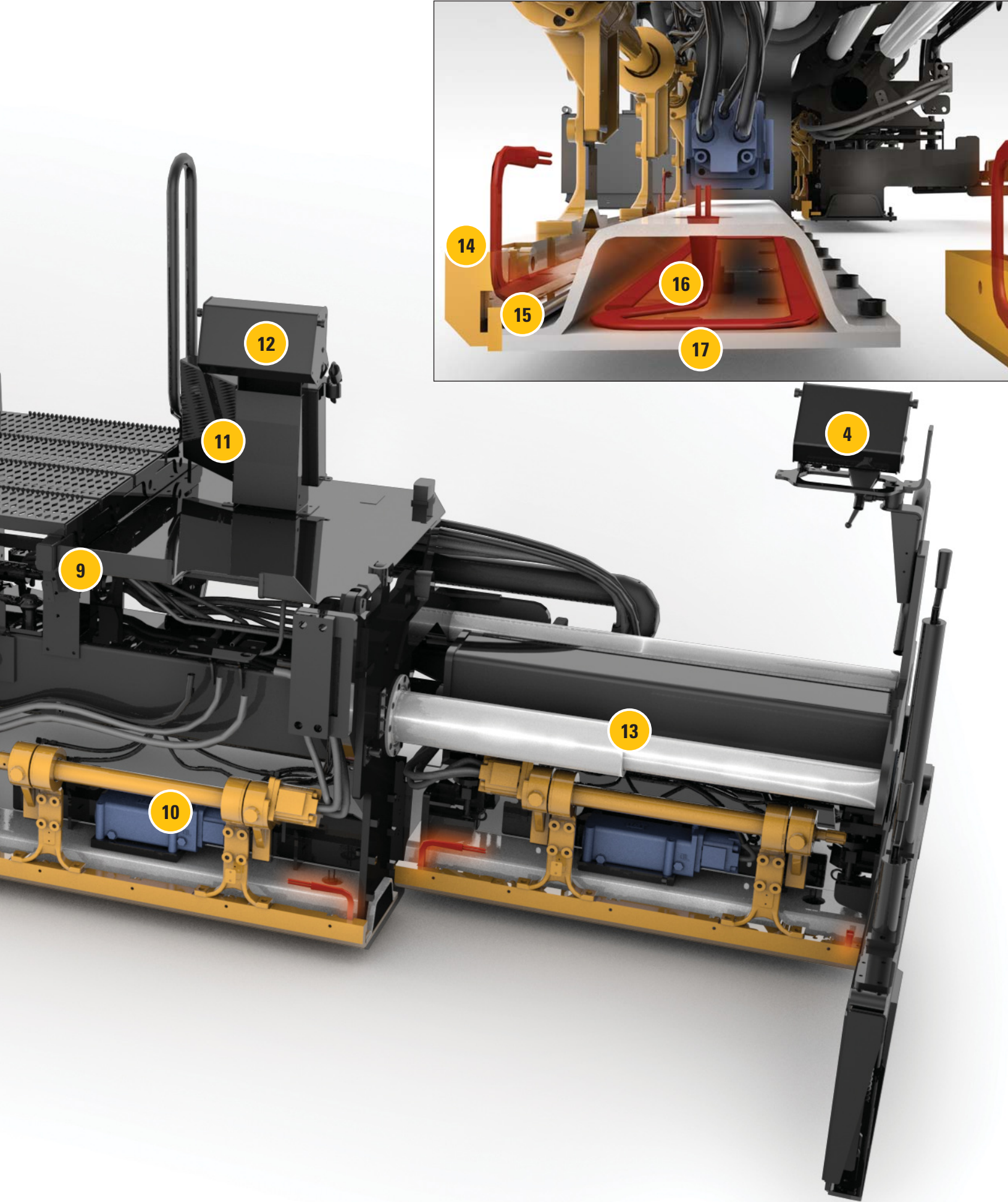

# HIGH DENSITY RESULTS

MAXIMIZE DENSITY BEHIND THE SCREED.



## HIGH DENSITY SCREED

- Balanced weight of 3200 kg (7,055 lb)
- Tamper bar system delivers an adjustable range up to 1700 rpm with a stroke of 4 mm (0.16")
- Adjustable vibratory screed plate range up to 3,000 vpm
- 330 mm (13") single main screed plate width
- 13 mm (0.5") screed plate thickness
- Electrically heated screed plates and tamper bars deliver uniform heat distribution
- Standard power crown control makes adjustments easy
- Bolt-on extensions are equipped with quick-connect couplings for easy installation
- Foldable rear walkway with locking capability minimizes transport length and allows positioning close to curbs and obstructions

## DOUBLE WIDTH EXTENDERS

- Double width hydraulic power extenders deliver a standard paving width up to 5.0 m (16' 4") and maximum span to 8.0 m (26' 4")
- Quick reacting extenders optimize performance around obstacles and turnouts
- Rigid frame prevents flexing for excellent mat quality

## SPRING-LOADED END-GATES

- Spring-loaded design delivers downward force to contain mix and follow the surface profile for better joint matching capability
- Heated end-gates (option) minimize build-up and improve mix flow
- Foldable end-gates (option) reduce overall width for easier transport
- Replaceable wear guides ensure consistent performance

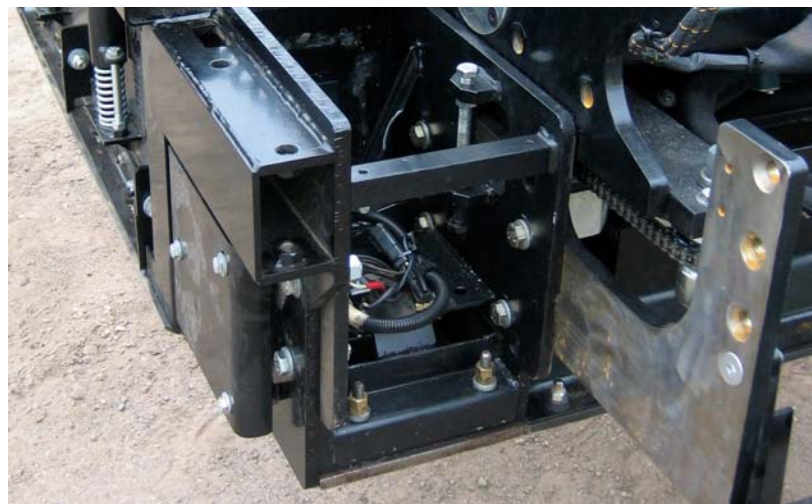

**Bolt-on Extensions**



# EASY OPERATION

## AUTOMATION INCREASES EFFICIENCY.

### ADVANCED SCREED CONTROL

- Main screed controls optimize productivity and are ergonomically located for day long comfort
- Screed counter-balance prevents settling for better mat quality
- Integrated sonic sensor harnesses ensure performance
- Remote extender controls include tow-point adjustment, width adjustment, and mix height
- Mix height dial provides precise control and maintains the head of material when paving varying depths and widths
- Standard power control for crown provides a range of +5% to -3%

### SCREED ADVISOR DISPLAY

- Available in multiple languages
- Keeps operator informed of the following:
  - Temperature of each screed section
  - Tamper bar speed
  - Vibratory speed
  - Counter-balance pressure

### MAIN SCREED CONTROLS

- Mounted on each extender for efficient operation
- Swivel capability for easy viewing from multiple positions
- Tow-point height adjustment
- Manual auger override
- Manual conveyor override
- Mix height dial
- Reversible conveyors
- Extender height adjustment
- Emergency stop switch
- Horn

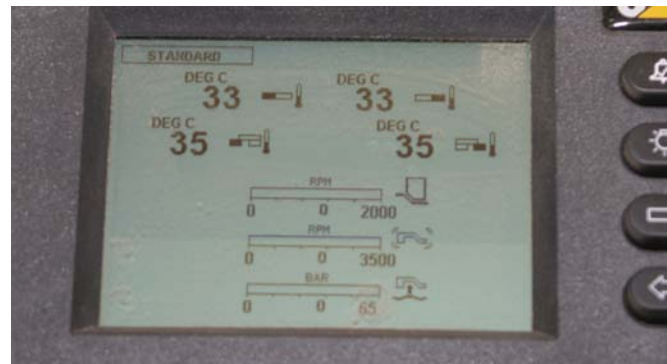



# CAT GRADE AND SLOPE SYSTEM

**FACTORY INTEGRATION,  
EASIER TO USE, MORE ACCURATE.**

*Cat Grade and Slope is a factory-integrated guidance system that helps remove irregularities from the surface and control mat thickness for increased production, lower operating costs, and higher profitability. It is entirely supported by Caterpillar; ensuring the control system and paver are setup to optimize performance and meet job site requirements.*

*Cat Dealers offer exceptional knowledge of the grade and slope system, as well as paver and screed operation, providing a single source that meets all your paving needs.*

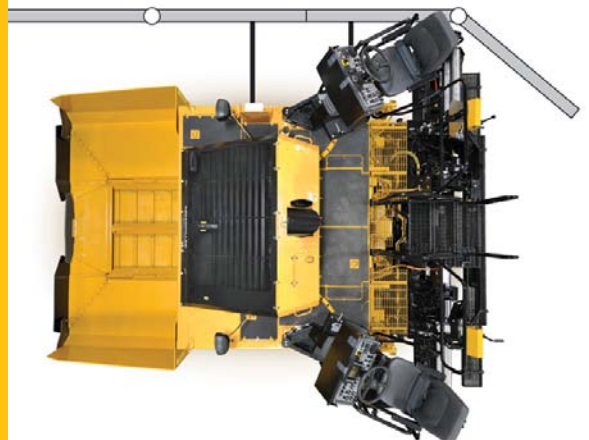



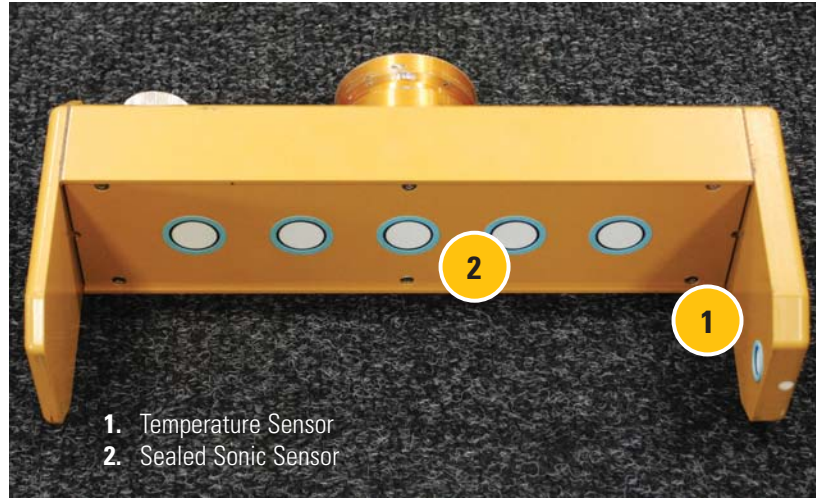

## GRADE AND SLOPE SYSTEM FEATURES

### SINGLE OR DUAL DISPLAYS – EASY VISUALIZATION

- Each LCD display is able to control one or both sides of the screed
- Text-based menus offer multiple languages
- Equipped with brightness and contrast controls for good visibility in various lighting conditions

### DURABLE ENCLOSURE

- Swivel capability enables visibility from a various positions
- Heavy-duty design provides overnight protection

### SONIC GRADE SENSORS

- Sonic sensor is equipped with five ceramic transducers in each sensor, two readings are discarded, three are averaged
- 457 mm (18") optimal height
- Built-in temperature sensor accounts for temperature variation; sealed, reliable

### CONTACTING GRADE SENSORS

- Two designs; ground contacting ski, wand-type for string lines
- Effective for curbs and joints

### SLOPE SENSOR

- Range of ±10 degrees (17.6%)
- Effective on super elevations

### SONIC AVERAGING BEAM

- Equipped with up to three sensors; when paving super elevations, the front and rear sensor can be turned off for better control of mat thickness
- Averages total deviations and adjusts tow-point by 1/3 for true averaging; Note: When utilizing two grade sensors, tow-point is adjusted by 1/2 of the total deviation.
- Sensor height can be individually adjusted
- Easily move to the next starting point without disassembly.

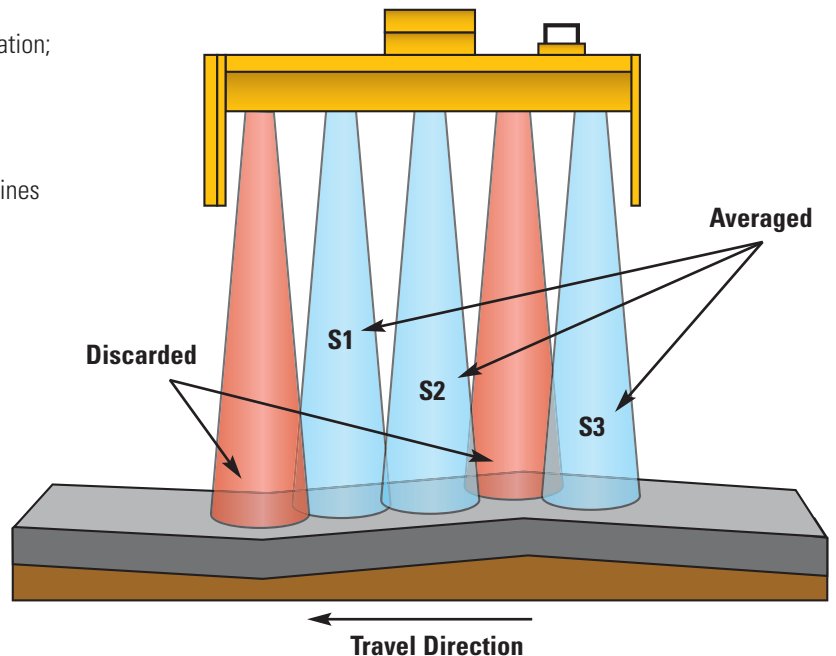

$$\frac{S1+S2+S3}{3} = \text{Tow-point Movement (True Averaging)}$$

# ADVANCED ELECTRIC SCREED HEAT

## TOUCH-PAD TECHNOLOGY WITH MULTI-ZONE HEATING AND EVEN-HEAT DISTRIBUTION.

### ELECTRIC HEAT FEATURES

- New high efficiency system delivers quick heat-up and even distribution to the entire screed plate surface
- Wide width paving packages also equipped with high efficiency system, delivering fast project start times
- Temperature sensors in each screed section, including extensions
- Three pre-set temperature settings for each screed section ensure even heat distribution
- Manual adjustments provide override capability
- Touch-pad technology and LED indicator lights create a user-friendly interface
- Flattened bar type heating elements deliver reliability
- On-board diagnostics enable operator to verify fault indicators

### TRACTOR-MOUNTED GENERATOR

- GFCI circuit breaker protection
- Fast heat-up at low idle.
- Manual breaker reset
- 25 kW generator
  - supplies 25 kW at 60 Hz with engine speed 1275 or higher
  - provides power to the electric screed and auxiliary power panel
  - utilized for normal lighting packages
- 35 kW generator
  - supplies 35 kW with engine speed at 1500 rpm or higher
  - provides power to the electric screed and two auxiliary power panels
  - utilized for large lighting packages and wide width tamper bar screed

### AUXILIARY POWER

- 7 kW of available power
- Supports high intensity discharge lighting (HID), power tools
- Panel is available with two, 240-volt receptacles **or** six, 120-volt receptacles and one, 240-volt receptacle

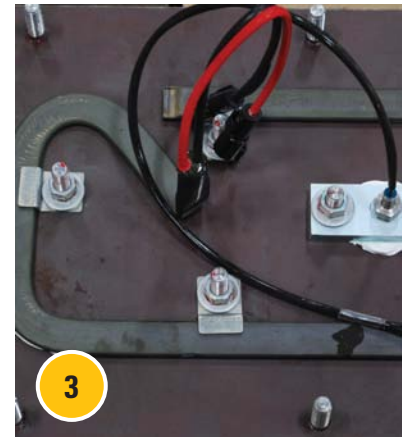
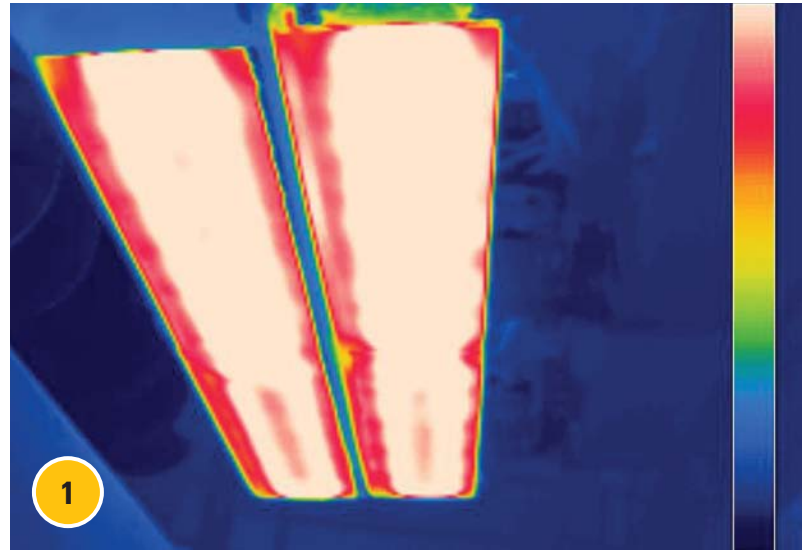

1. Even Heat Distribution
2. Electric Heat Panel
3. Heating Element
4. Generator
5. Auxiliary Panel

# PAVING WIDTHS

## EXTENSIONS MAXIMIZE VERSATILITY

### AS4252C SCREED EXTENSIONS

Bolt-on extensions are available in lengths of 0.25 m (10") and 0.75 m (30"). Quick-connect hydraulic couplings simplify attachment.

- 0.25 m (10") extensions are electrically heated with tamper bars
- 0.75 m (30") extensions are electrically heated with tamper bars and vibration

\* Maximum paving range when utilized with AP500E is 7.0 m (23').

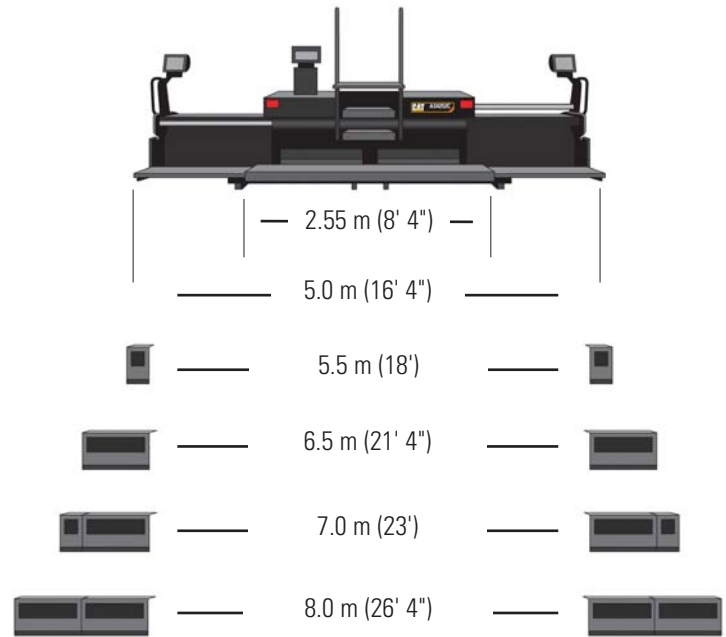

## AS4252C SCREED SPECIFICATIONS

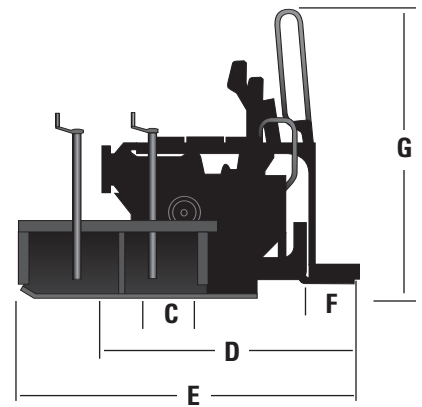
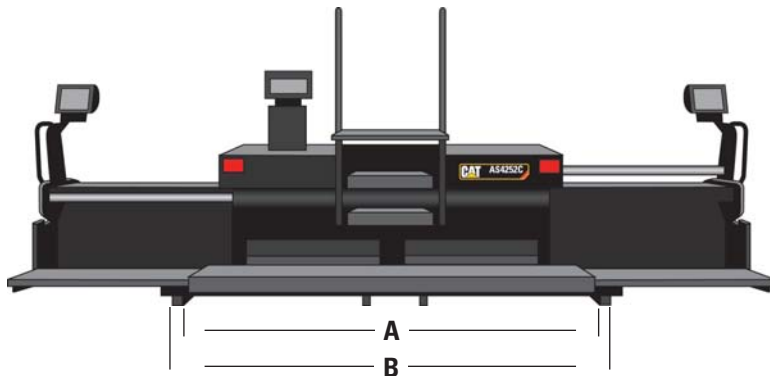

Dimensions	
<b>A</b> Width without end gates (retracted)	2550 mm (100")
Width with foldable end gate option	2550 mm (100")
Width with end gates (retracted)	2730 mm (107")
<b>B</b> Hydraulically extendable width	5.0 m (16' 4")
<b>C</b> Main screed plate width	330 mm (13")
Extender screed plate width	330 mm (13")
Screed plate thickness	13 mm (0.51")
<b>D</b> Length without end gates (front to back)	1750 mm (69")
<b>E</b> Length with end gates (front to back)	2300 mm (91")
<b>F</b> Walkway width	330 mm (13")
<b>G</b> Height	1935 mm (76")

Weights	
Screed	3200 kg (7,055 lb)
250 mm (10") extension	70 kg (154 lb)
750 mm (30") extension	300 kg (661 lb)

Screed Adjustments	
Crown range	+5% to -3%
Height indicator increment	6.4 mm (0.25")
Slope (horizontal)	+4% to -4%
Vibrator speed	0 - 3000 vpm
Tamper bar speed	1700 rpm
Tamper stroke	4 mm (0.16")
Screed heating	electric

# AS4252C VIBRATORY AND TAMPER BAR SCREED

For more complete information on Cat products, dealer services, and industry solutions, visit us on the web at [www.cat.com](http://www.cat.com)

© 2011 Caterpillar  
All Rights Reserved

Materials and specifications are subject to change without notice.  
Featured machines in photos may include additional equipment.  
See your Cat dealer for available options.

CAT, CATERPILLAR, ACERT, their respective logos, and "Caterpillar Yellow," as well as corporate and product identity used herein, are trademarks of Caterpillar and may not be used without permission

QEHO1504 (6/11)

