

AS3301C

Extend-A-Mat™ Screed

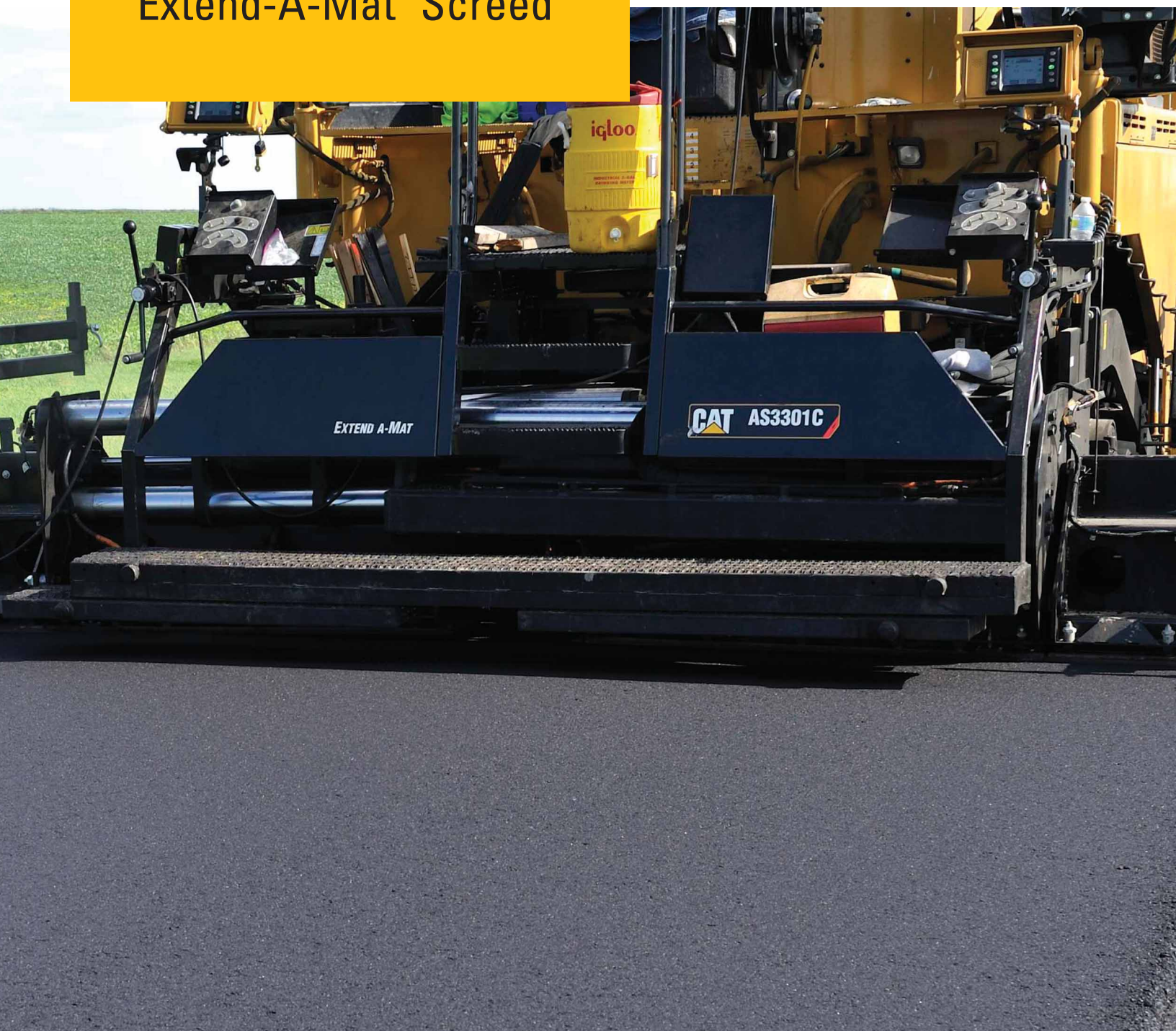

AS3301C Screed Weight	3266 kg	7,200 lb
Paving Ranges:		
Hydraulically extendable	3.05 m - 5.94 m	10' - 19' 6"
w/Bolt-on extensions	3.05 - 7.37 m	10' - 24' 2"
w/Cutoff shoes	2.44 m	8'

AS3301C EXTEND-A-MAT™ SCREED

The AS3301C vibratory screed delivers smooth results and excels in high-production, wide-width paving applications. The rigid frame, fast heating electric screed, and user-friendly controls, make this screed the choice of mainline paving contractors. It incorporates an electronic control module, CANbus electrical system, and simplified screed plate leveling system for easy service and long-term reliability.

APPLICATIONS

- Interstates
- Airports
- Highways
- Residential streets
- City streets
- Parking lots

CONTENTS

Smoothness Features	4
Operating Environment	5
Quick Adjustments	6
Service and Reliability	7
Cat Grade and Slope	8, 9
Electric Screed Heat	10
Paving Widths	11
Specifications	11

SMOOTH RESULTS

- Rigid frame and balanced weight design prevents flexing for optimal mat quality
- Maximum paving range of 2.44 m - 7.37 m (8' - 24' 2")
- Main screed pre-strike-off ensures smooth flow under the screed
- Main and extender screed plates are 457 mm (18") wide providing optimal smoothness
- Triangular extender support configuration delivers stability for wide width paving
- Spring-loaded end gates deliver downward pressure to contain mix for tight edges and smooth joints

LEADING-EDGE TECHNOLOGY

- Cat® Grade and Slope Automation offers more precise control and a visual display with multiple language options
- CANbus electrical system reduces wiring requirements for increased reliability
- Electronic Control Module (ECM) is compatible with Cat ET for fast and easy diagnostics

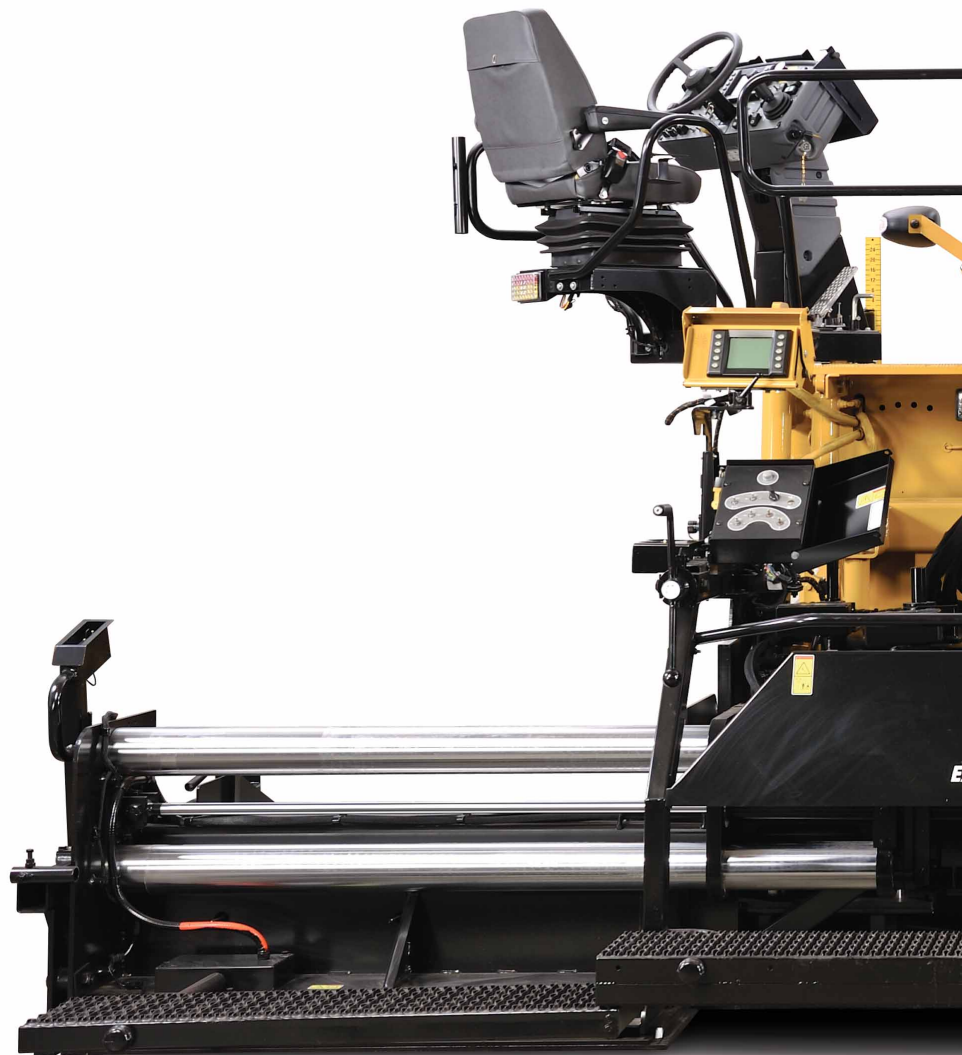

ADVANCED SCREED CONTROL

- Main screed controls ergonomically located for optimal efficiency
- Mix height dial easily maintains head of material
- Remote extender controls provide easy access for efficient operation
- Power controls simplify adjustments for crown, height, and slope
- Thickness control screws are equipped with spinner handles for fast, easy adjustment
- Integrated sonic sensor harnesses increase reliability, minimize potential damage

FAST HEATING ELECTRIC SCREED

- Quick and even screed plate heating at low idle
- User-friendly touch pad technology simplifies operation
- Three pre-set temperature settings for each screed section
- Manual override capability

EXCELLENT SERVICE AND RELIABILITY

- Electronic Control Module (ECM) simplifies troubleshooting procedures
- Easy component access simplifies routine service
- Well-designed hydraulic routings are protected with kevlar braid
- Color-coded electrical wiring simplifies troubleshooting procedures
- O-ring face seals (ORFS) offer durability and prevent leaks



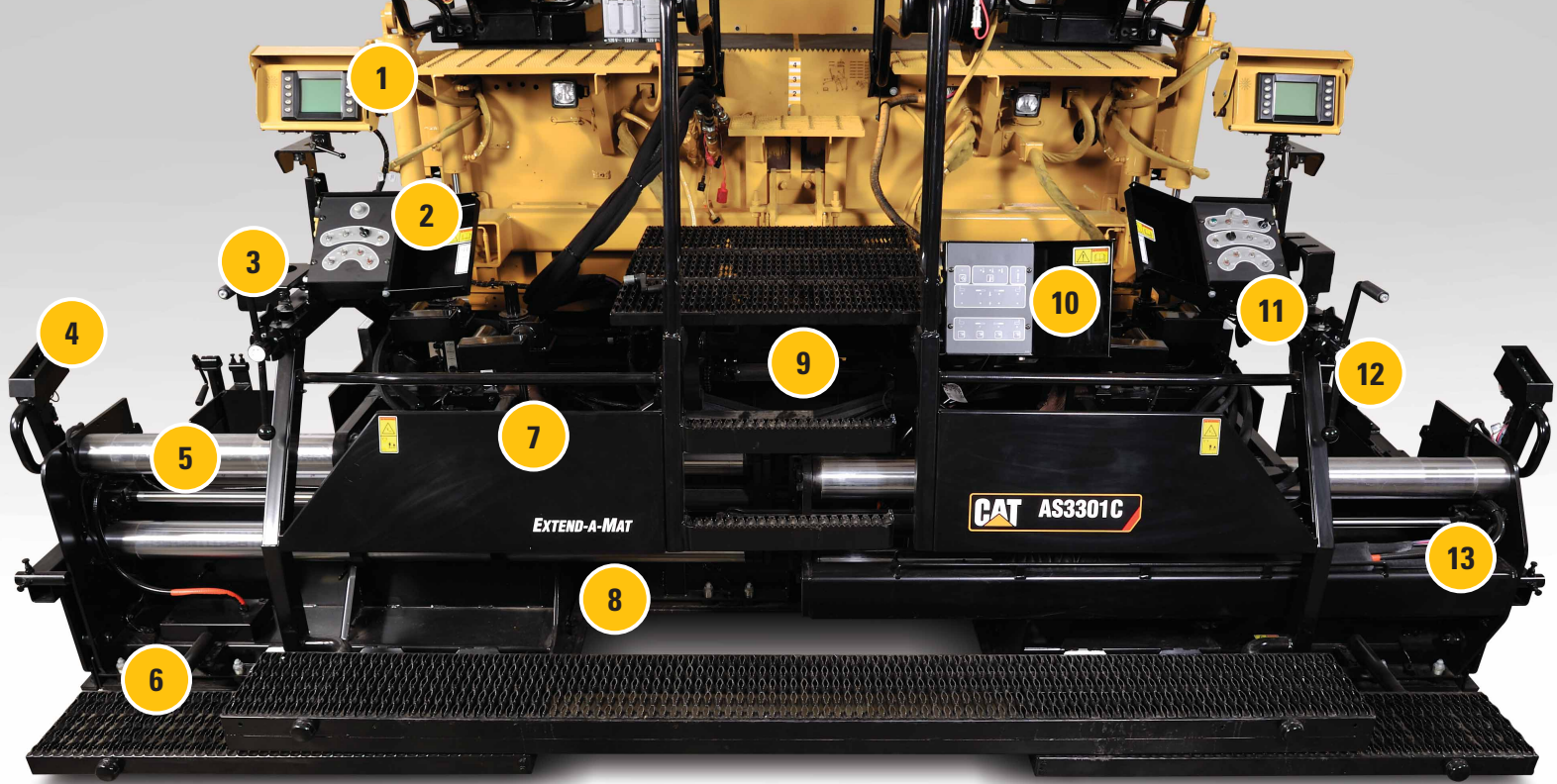

SMOOTHNESS FEATURES

**STABLE DESIGN, AWARD WINNING
PERFORMANCE.**

1. Cat Grade and Slope
2. Power Screed Controls
3. Folding Cup Holder
4. Remote Extender Controls
5. Rigid Support Tubes
6. Threaded-Bolt Screed Adjusters
7. Tool Box
8. Electrically Heated Screed Plates
9. CANbus Electrical System
10. Electric Heat Control Panel
11. Main Screed Controls
12. Spinner Handles on Depth Cranks
13. Integrated Sonic Sensor Wiring

SCREED PLATES

- Main and extender plates are 457 mm (18") wide (front to back)
- Hardened alloy steel resists abrasion
- Curved nose-bar design delivers pre-compaction and smooth flow

RIGID EXTENDER DESIGN

- Dual extending support tubes and third frame member form a triangular design that delivers excellent torsional resistance and rigidity
- Visual width indicators keep operators informed of paving width
- Extenders are equipped with vibration and heat

VIBRATOR SYSTEM

- Provides initial compaction
- Located on main screed and extenders
- Adjustable range of 0 - 3000 vpm
- Vibration on extenders is synchronized to match the main screed

SPRING-LOADED END GATES

- Delivers an adjustable force allowing the end gates to follow the paving surface
- Ensures contact with the mat to create a confined joint
- Eliminates protrusions, enabling the extender to pave close to curbs and obstructions
- Replaceable wear strip ensures performance

OPERATING ENVIRONMENT

DESIGNED WITH EFFICIENCY IN MIND.

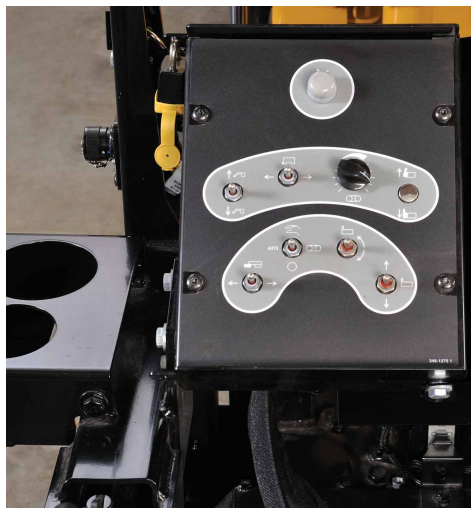

LEFT MAIN SCREED CONTROLS

- Tow-point height
- Power mainframe extension (option)
- Mix height control dial
- Extender width
- Feed system override
- Extender slope
- Extender height

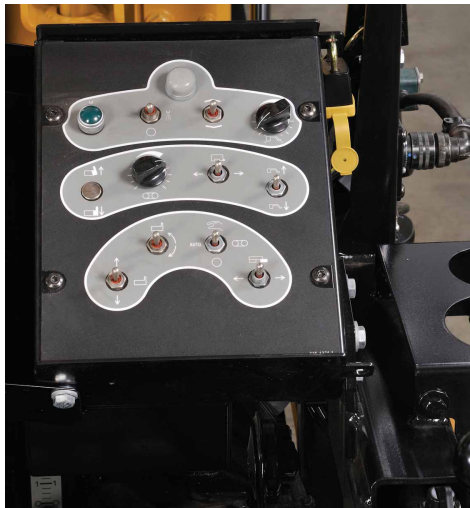

RIGHT MAIN SCREED CONTROLS

- Eco-washdown switch
- Power crown control
- Vibratory frequency control
- Power berm (option)
- Mix height dial
- Power mainframe extension (option)
- Tow-point height
- Extender height
- Extender slope
- Feed system override
- Extender width



REMOTE EXTENDER CONTROL

- Tow-point height
- Feed system override
- Extender width

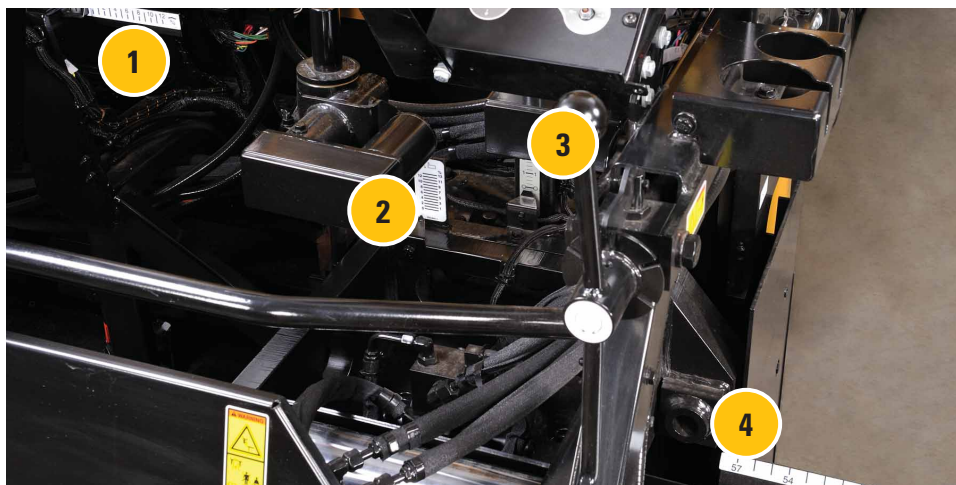

1. Crown Indicator
2. Extender Slope Indicator
3. Extender Height Indicator
4. Extender Width Indicator

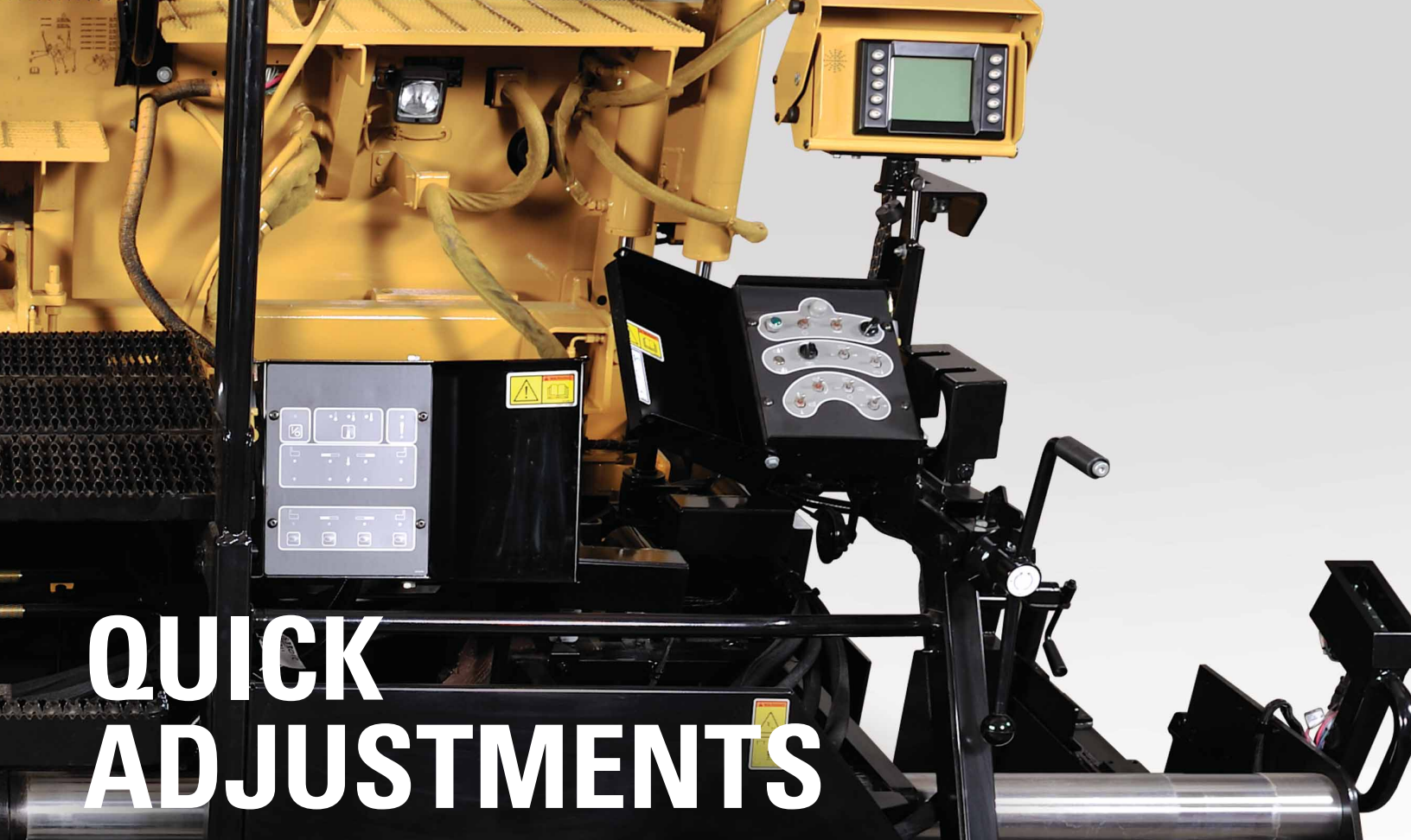

QUICK ADJUSTMENTS

AUTOMATED OPERATION INCREASES EFFICIENCY.

PRE-STRIKEOFF

- Adjustable height pre-strikeoff mounted in front of the main screed plate controls material flow under the screed
- Factory setting is 25.4 mm (1") above the screed plate, exposing the nose bar

THICKNESS CONTROL SCREWS

- Equipped with spinner handles for quick, easy adjustment
- An adjustment of 25.4 mm (1") requires 8 turns
- Choice of left or right hand depth control threads to suit operator preferences

POWER CONTROLS

- Crown angle, +10% to -3%
- Extender slope percent, +14% to -2%
- Extender height, 6.4 mm (0.25") increments



1. Adjustable pre-strikeoff
2. Curved nose bar
3. 13 mm (0.5") hardened alloy screed plate

SERVICE AND RELIABILITY

OPTIMIZE PERFORMANCE, MAXIMIZE SERVICE LIFE.

Simplified leveling and easy diagnostics leads to higher productivity and increased profits.

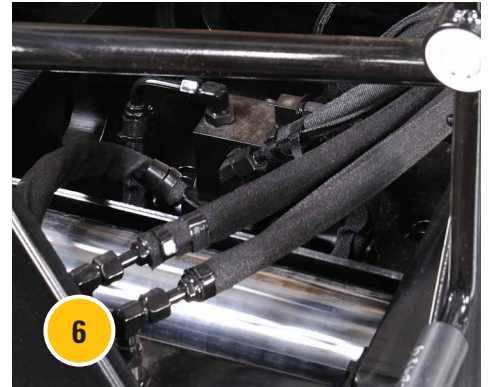
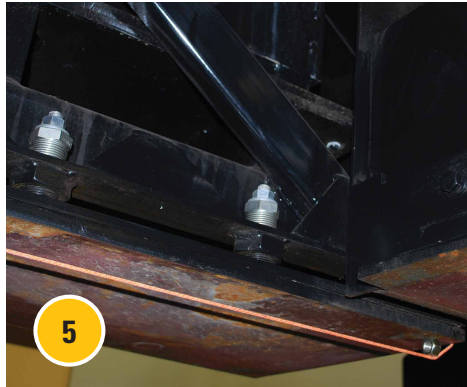

ELECTRONIC CONTROL MODULE (ECM)

- ECM is compatible with Cat ET for fast and easy diagnostics
- Simplifies/reduces wiring requirements
- Controls screed electrical functions

SCREED PLATE ADJUSTMENT

- Front and rear threaded-bolt adjusters simplify screed plate leveling and eliminate shims
- Saves time when installing new screed plates
- Adjustment hardware is plated to resist corrosion

PROTECTED ROUTINGS

- Hydraulic hoses and electrical wiring are strategically routed, clamped in place, and wrapped with kevlar braid to ensure reliability and prevent abrasion

REMOTE GREASE FITTINGS

- Vibrator bearings are equipped with easy to access grease fittings that enable simplified service

O-RING FACE SEALS

- O-ring face seals and couplings optimize contact to ensure performance and prevent leaks

RELIABLE ELECTRICAL SYSTEM

- Color-coded, numbered, and soldered electrical system simplifies service and delivers reliability

4. Electronic Control Module (ECM)
5. Screed plate adjustment
6. Protected hydraulic and electrical routing



CAT GRADE AND SLOPE SYSTEM

**FACTORY INTEGRATION,
EASIER TO USE, MORE ACCURATE.**

Cat Grade and Slope is a factory-integrated guidance system that helps remove irregularities from the surface and control mat thickness for increased production, lower operating costs, and higher profitability. It is entirely supported by Caterpillar; ensuring the control system and paver are setup to optimize performance and meet job site requirements.

Cat Dealers offer exceptional knowledge of the grade and slope system, as well as paver and screed operation, providing a single source that meets all your paving needs.

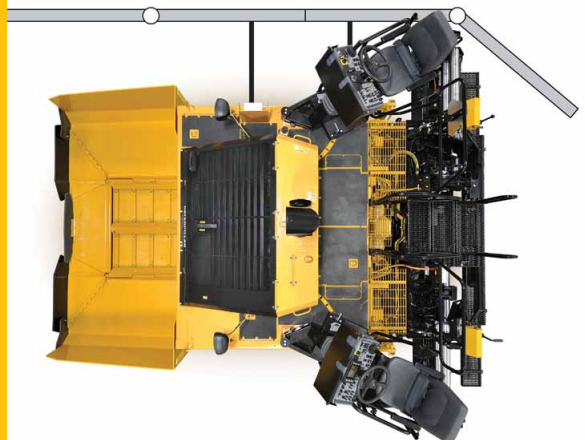

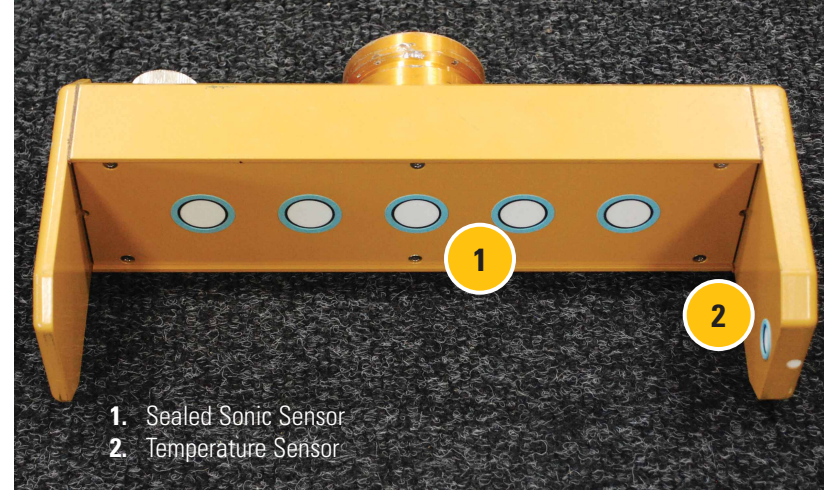

GRADE AND SLOPE FEATURES

SINGLE OR DUAL DISPLAYS – EASY VISUALIZATION

- Each LCD display is able to control one or both sides of the screed
- Text-based menus offer multiple languages
- Equipped with brightness and contrast controls for good visibility in various lighting conditions

DURABLE ENCLOSURE

- Swivel capability enables visibility from a various positions
- Heavy-duty design provides overnight protection

SONIC GRADE SENSORS

- Sonic sensor is equipped with five ceramic transducers in each sensor, two readings are discarded, three are averaged
- 457 mm (18") optimal height
- Built-in temperature sensor accounts for temperature variation; sealed, reliable

CONTACTING GRADE SENSORS

- Two designs; ground contacting ski, wand-type for string lines
- Effective for curbs and joints

SLOPE SENSOR

- Range of ±10 degrees (17.6%)
- Effective on super elevations

SONIC AVERAGING BEAM

- Equipped with up to three sensors; when paving super elevations, the front and rear sensor can be turned off for better control of mat thickness
- Averages total deviations and adjusts tow-point by 1/3 for true averaging; Note: When utilizing two grade sensors, tow-point is adjusted by 1/2 of the total deviation.
- Sensor height can be individually adjusted
- Easily move to the next starting point without disassembly.

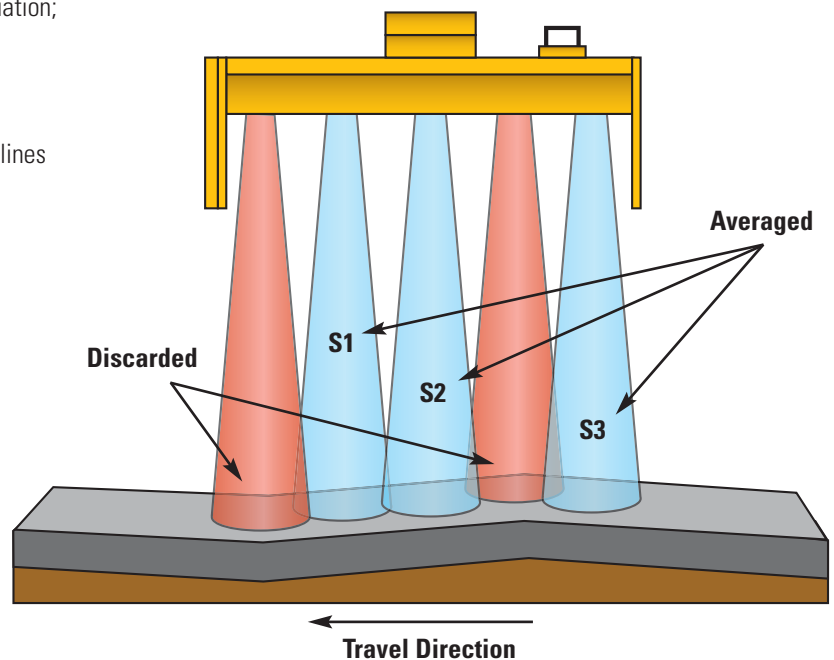

$$\frac{S1+S2+S3}{3} = \text{Tow-point Movement (True Averaging)}$$

ADVANCED ELECTRIC SCREED HEAT

TOUCH-PAD TECHNOLOGY WITH MULTI-ZONE HEATING AND EVEN-HEAT DISTRIBUTION.

ELECTRIC HEAT FEATURES

- Touch-pad technology and LED indicator lights create a user-friendly interface.
- Three pre-set temperature settings for each screed section ensure even heat distribution
- Manual adjustments provide override capability
- Flattened bar type heating elements deliver reliability
- Temperature sensors in each screed section, including extensions
- On-board diagnostics enable operator to verify fault indicators

TRACTOR-MOUNTED GENERATOR

- GFCI circuit breaker protection
- Fast heat-up at low idle.
- Manual breaker reset
- 25 kW generator
 - supplies 25 kW at 60 Hz with engine speed 1275 or higher
 - provides power to the electric screed and auxiliary power panel
 - utilized for normal lighting packages
- 35 kW generator
 - supplies 35 kW with engine speed at 1500 rpm or higher
 - provides power to the electric screed and two auxiliary power panels
 - utilized for large lighting packages and wide width tamper bar screed

AUXILIARY POWER

- 7 kW of available power
- Six, 120-volt receptacles
- One, 240-volt receptacle
- Supports high intensity discharge lighting (HID), power tools

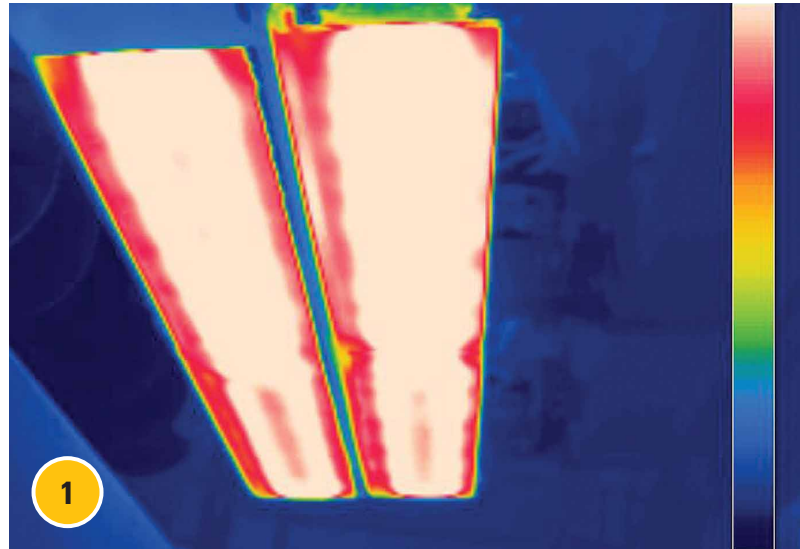

1. Even Heat Distribution
2. Electric Heat Panel
3. Heating Element
4. Generator
5. Auxiliary Panel

PAVING WIDTHS

EXTENSIONS MAXIMIZE VERSATILITY

AS3301C SCREED EXTENSIONS

These extensions are available in 305 mm (1') and 711 mm (2' 4") lengths.

- 305 mm (1') extensions are electrically heated
- 711 mm (2' 4") extensions are electrically heated with vibration

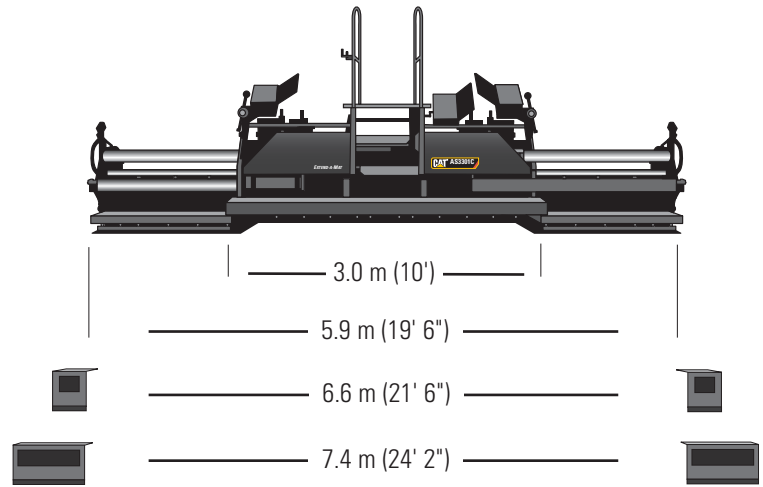

AS3301C Screed Specifications

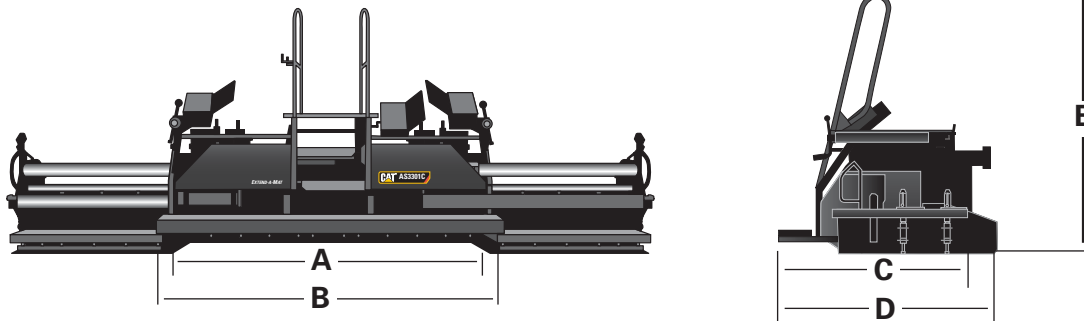

Dimensions and Weights

A	Retracted width w/o end gates	3062 mm (120")
B	Retracted width w/ end gates	3332 mm (131")
C	Length w/o end gates (front to back)	1765 mm (69")
D	Length w/ end gates (front to back)	2271 mm (89")
E	Height	2114 mm (83")
	Screed plate width	457 mm (18")
	Screed plate thickness	13 mm (0.5")
	Extender slope	+10% to -3%
	Main crown	+10% to -3%
	Vibrator speed range	2700 - 3300 rpm

Weight 3266 kg (7,200 lb)

Paving Widths

Standard extendable range	3.05 m - 5.94 m (10' - 19' 6")
Maximum range	2.44 m - 7.37 m (8' - 24' 2")
Maximum paving depth	300 mm (12")

AS3301C Extend-A-Mat™ Screed

For more complete information on Cat products, dealer services, and industry solutions, visit us on the web at www.cat.com

© 2011 Caterpillar
All Rights Reserved

Materials and specifications are subject to change without notice.
Featured machines in photos may include additional equipment.
See your Cat dealer for available options.

CAT, CATERPILLAR, ACERT, their respective logos, and "Caterpillar Yellow," as well as corporate and product identity used herein, are trademarks of Caterpillar and may not be used without permission

QEHO1492 (9/11)

