

AP655D

Asphalt Paver



Cat® C6.6 Engine with ACERT™ Technology

Gross Power (SAE J1995) at 2200 rpm 129.5 kW/176 hp

Net Power (ISO 9249) at 2200 rpm 121.9 kW/165.8 hp

Operating Weight with

AS4251C Screed 19 165 kg

Hopper Capacity

6.5 m³ (14.1 tonne)

Standard Paving Range

AS4251C Screed 2550-5000 mm

Maximum Paving Width

AS4251C Screed 8000 mm

High Performance and Operator Comfort Make the AP655D the Perfect Choice

The AP655D sets the standard in performance, operator comfort, ease of use, mobility and reliability.

C6.6 Engine with ACERT™ Technology

ACERT™ Technology works at the point of combustion to optimize engine performance. The combination of large displacement and high torque allow the AP655D to perform under the toughest conditions. A refined air management system generates fewer emissions and optimize fuel combustion while meeting European EU Stage IIIA engine emission regulations. **pg. 4**

Dual Operator's Station

The AP655D utilizes dual swing-out operator's station with sliding control console. The stations can be rotated into five different positions and the sliding control console provides operator comfort. The operator's stations can be positioned beyond the machine frame for greater visibility to the steering guide when matching a joint or paving near curbs, where precise paving control is required. **pg. 5**

Advisor Monitoring System

The LCD Advisor located on the sliding control console provides an interactive interface to assist the operator. The system includes project planning calculators, start-up checklists, engine operating parameters and many other features to assist the operator. **pg. 5**

High Capacity Cooling System and Ventilation System

The high-capacity top-mounted cooling system performs efficiently in high ambient temperatures. The variable speed fan draws air across the engine compartment and exhausts it toward the hopper in order to provide a cooler working environment for the crew. Augers fumes extraction efficiently keeps asphalt fumes away from screed crew and operator. **pg. 4**

Screed

The AP655D is available with the AS4251C double width hydraulic power extendible asphalt screed, available with variable frequency tamper and vibrators and with LPG and electric heating system. The AS4251C lay material to the desired width and depth while providing a smooth finish with initial compaction. **pg. 8**

Cat® Asphalt Pavers continue to lead the industry and meet your demanding job requirements.

Many easy-to-use features and technologies have been developed in order to guide your crew in producing high quality mats time and time again. Contact your Caterpillar® Dealer today for more information.



Versatility Defines the AP655D

The AP655D excels in a wide range of applications from routine commercial jobs to demanding highway operations.

Undercarriage

The AP655D can be equipped with either the Mobil-trac™ undercarriage or the steel track undercarriage. The Mobil-trac system combines the traction and flotation benefits of a crawler undercarriage with the mobility, speed, and ride characteristics of a wheel paver. A steel track undercarriage is available as a more economical alternative. **pg. 6**

Maneuverability

Cat track-type pavers provide maneuverability that is unmatched in the industry. The AP655D utilizes three steering modes including PAVE, TRAVEL and MANEUVER. The MANEUVER mode is unique to Caterpillar. This mode permits the tracks to counter-rotate, allowing the machine to turn within its own footprint. This unique feature provides quick mobility in commercial applications when moving to a new starting point.

Independent Material Handling System

The material handling system provides precise mix delivery through the most proven system in the industry. The independent operation of the augers and conveyors reduces component wear and minimizes the potential for mix segregation.

Reversible augers and conveyors assist the crew by reducing handwork and clean-up. The reversible augers are able to pull asphalt back into the main screed area when retracting the extenders while the reversible conveyors pull asphalt back into the tunnels, resulting in limited spillage.

pg. 7

Generator and Auxiliary Power Panel

The optional high capacity generator quietly powers the standard electric screed heat system for fast heat-up and uniform screed plate temperatures. The optional auxiliary power panel provides power for lighting and job site work tools. **pg. 8**



Cat C6.6 Engine with ACERT™ Technology

ACERT™ Technology incorporates a series of innovations working at the point of combustion to optimize engine performance while providing high reliability and easy servicing.



Cat C6.6 Engine with ACERT Technology. The C6.6 engine provides a full-rated gross power (SAE J1995) of 129.5 kW (176 hp) at 2200 rpm. Meets European EU Stage IIIA engine emission regulations.

Turbocharged and Air-To-Air Aftercooling (ATAAC).

The turbocharged air-to-air aftercooling system provides high horsepower with increased response time while keeping exhaust temperatures low for long hours of continuous operation. Air-to-air aftercooling keeps air intake temperatures down, maximizing fuel efficiency and minimizing emissions.

Sound Reduction features. The C6.6 engine sound reduction features include composite valve covers with a fully isolated base, a steel oil pan and a cast iron front cover. A common rail fuel system also provides control of sound and vibration levels.

Service, Maintenance and Repair. Easier service, maintenance and repair is accomplished by monitoring key functions and logging critical indicators. Advanced electronic diagnostic capabilities are possible using Cat Electronic Technician.

High Capacity Cooling System and Optional Ventilation System

The deck-mounted cooling system provides a cool environment by exhausting hot air toward the hopper, away from operators and ground personnel. The ventilation system promotes a significant reduction of asphalt fumes for operator and crew comfort.



High Ambient Temperature Cooling System. The standard, high-capacity cooling system provides efficient operation in high ambient temperatures. The system design provides quiet operation that benefits the operator and the surrounding environment.

Efficient Airflow design. The airflow design draws ambient air across the engine compartment and through the coolers. This design allows the exhaust air to exit toward the hopper in order to provide a cooler engine compartment and cooler operating environment.

Variable Speed Fan. The variable speed fan is electronically controlled and hydraulically driven to provide on-demand cooling. This on-demand operation reduces engine power demand, lowers sound levels, and increases fuel efficiency.

Ventilation System. A suction system efficiently removes asphalt fumes from the auger chamber area assuring the best operating conditions and comfort for the crew. Asphalt fumes extraction with hydraulically driven fan is combined with engine exhaust into a single outlet stack.

Operator Comforts for a Productive Environment

The dual operator's station with sliding control console promotes optimum comfort, visibility and ease of use.



Dual Operator's Station. The ergonomic dual operator's station incorporates a sliding control console, ground speed indicators, adjustable suspension seats, armrests and retractable seat belts.

Operator Visibility. The dual swing-out operator's station can be positioned in one of five different locations to provide optimum visibility. The stations can extend beyond the machine frame for good visibility when paving applications require precise control.

Sliding Control Console. The sliding control console is fully equipped with comprehensive controls allowing the operator to conveniently monitor all machine functions. A lockable vandal cover protects console controls.

Canopy option. The optional folding canopy provides full width with two side extending wings for optimum comfort and protection. The canopy can be lowered manually for easy transportation.

Advisor Monitoring System Simplifies Operation

The sliding control console includes the Advisor Display that provides many unique features to assist the operator.



Advisor Monitoring System (AMS). The LCD Advisor provides access to a start-up checklist, operator preferences, engine and machine operating parameters and "Paving Calculator".

The AMS display also allows the operator to:

- Calibrate the machine components
- Set the automatic engine speed control
- Monitor engine rpm's and operating temperatures
- Determine the required paving speed and tonnage requirements for a particular job
- Determine performance parameters such as distance traveled, operating hours, paving distance, paving hours, and engine fuel consumption
- Set the optional friction steering tension to the operator's preference

Mobil-trac Undercarriage Performs in All Applications

The Mobil-trac™ undercarriage provides superior durability while delivering unmatched mobility, ride, and traction in a variety of conditions.

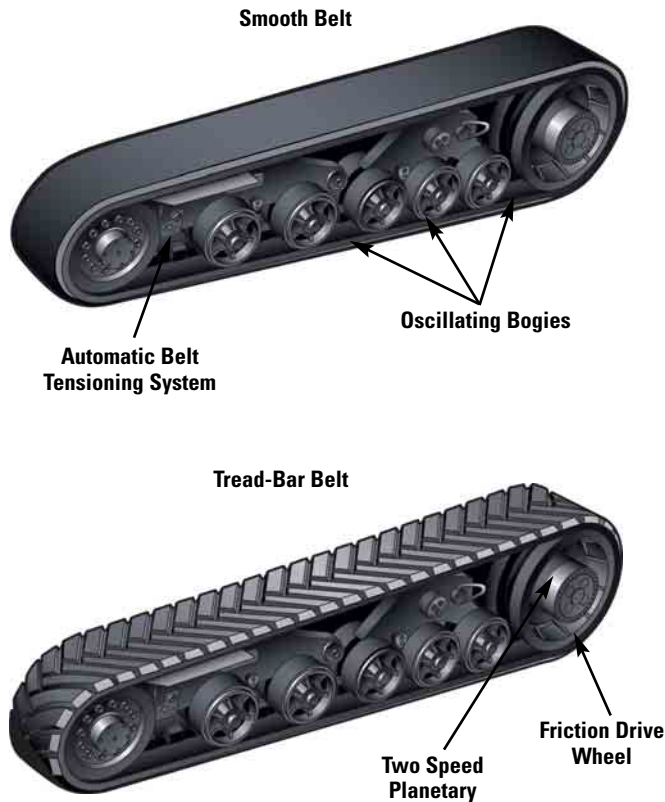

Mobil-trac Undercarriage. The Mobil-trac undercarriage combines the flotation and traction benefits of a crawler suspension with the mobility and ride quality of a wheel-type paver.

The Mobil-trac system includes a durable, high strength rubber track belt with a thick outer cover and internal layers of flexible steel cable.

Large Ground Contact Area. The Mobil-trac's ground contact area is 3020 mm long and 406 mm wide. This large footprint provides uniform weight distribution over the entire length of the belt.

Choice of Belt Designs. The Mobil-trac system offers a tread-bar style belt or a smooth belt. Both belt styles are 58 mm thick and provide good performance and wear characteristics, however, the smooth belt with beveled edges provides less disturbance on soft base materials.

Two Speed Planetary Drive. A fixed displacement motor drives a two-speed planetary providing quick mobility around the job site.

Steel Track Undercarriage

The steel track undercarriage is available as an economic alternative to the Mobil-trac.

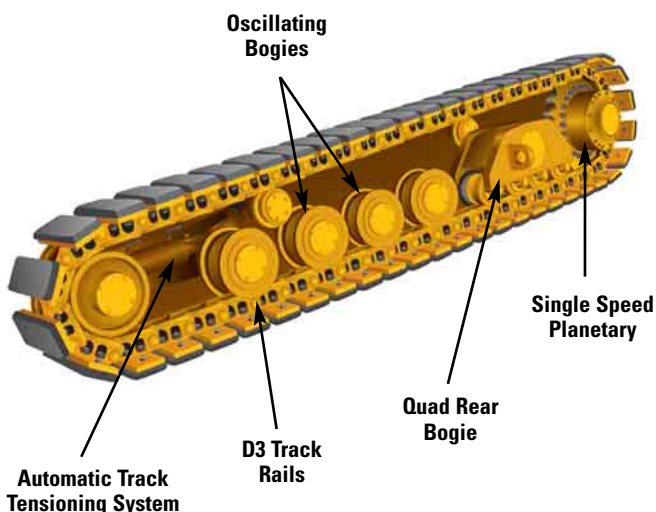

Quad Rear Bogie. A special quad bogie is positioned near the rear of the steel track in order to evenly distribute the load.

D3 Track Rails. The steel track system incorporates D3 dozer track rails. The sealed and lubricated links include a split master link for dependable performance.

Long Life Bonded Track Pads. The track pads contain a special rubber compound in order to provide long life and good traction.

Single Speed Planetary Drive. A variable displacement motor drives a single-speed planetary that provides variable speed selection.

Large Ground Contact Area. The steel tracks ground contact area is 3048 mm long and 356 mm wide. This large footprint provides uniform weight distribution over the length of the track.

Independent Material Handling System Promotes Hands-Free Operation

The material handling system promotes hands-free operation by providing features such as independent control of each auger and each conveyor.

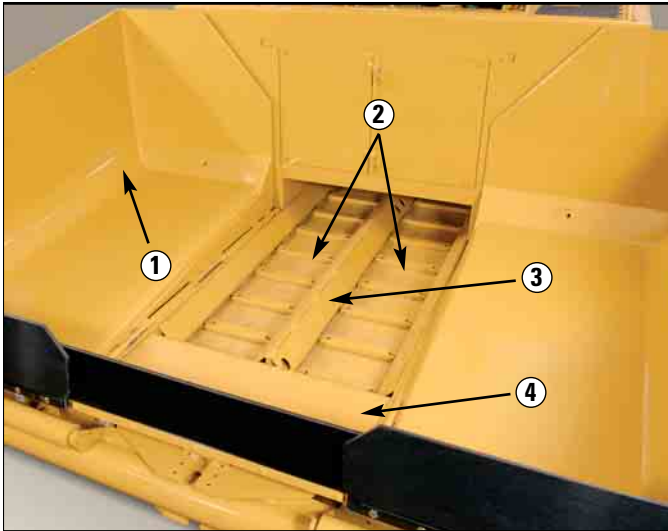

Precise Mix Delivery. The material delivery system provides precise mix delivery with minimal operator monitoring. The left and right conveyors in addition to the left and right augers are controlled independently.

Outboard-Mounted Conveyor Drives. The conveyors have outboard-mounted motors, reducers and drive chains that maximizes the tunnel area and reduces segregation.

Independent Auger Drive. The auger drive assembly is independent of the tractor which allows the distance between the two conveyors to be significantly reduced. Keeping the conveyors close together allows the material to flow together more easily as it discharges into the auger cavity. The tunnel and auger design eliminates voids under the chain case in order to minimize segregation.

Adjustable Auger Range. The auger assembly is hydraulically adjustable with a range of 215 mm. The ability to adjust the auger assembly simplifies loading and unloading from a transport vehicle. Also, when working with larger stone mixes, the augers can be adjusted to allow the mix to flow unrestricted under the auger assembly.

Power Folding Front Apron (Optional). The front hopper apron folds rearward providing good material flow. It reduces clean out effort and time, a feature the crew will really appreciate. A switch located on the operating control console provides power to the hydraulic folding apron.

*Note: The front hopper apron is standard *without* the power control and folding wings. Manual operation is required.

Adjustable Push Rollers. The four position adjustable push rollers provide a contact point between the paver and the truck to center the load and assist steering while unloading.

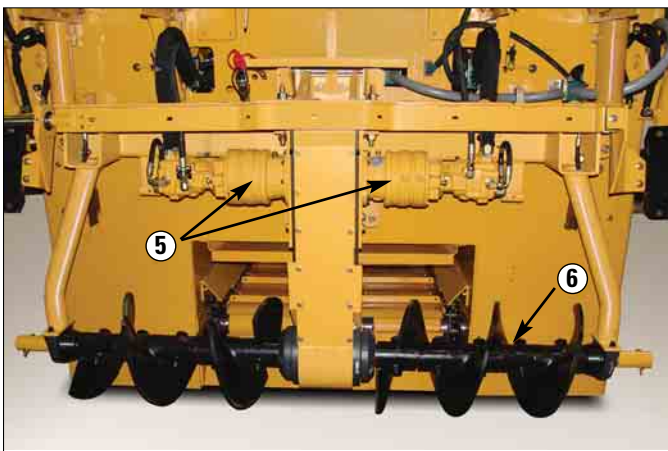

- 1 Curved Hopper Design
- 2 Independently Controlled Conveyors
- 3 Narrow Chain Guard
- 4 Folding Front Apron
- 5 Independent Auger Drives
- 6 406 mm Auger Diameter Conveyors
- 7 Foldable Wings
- 8 Power Folding Front Apron

Optional Generator System Provides Quiet Power

The high capacity generator provides power for the electric screed heat, auxiliary lights and job site tools.

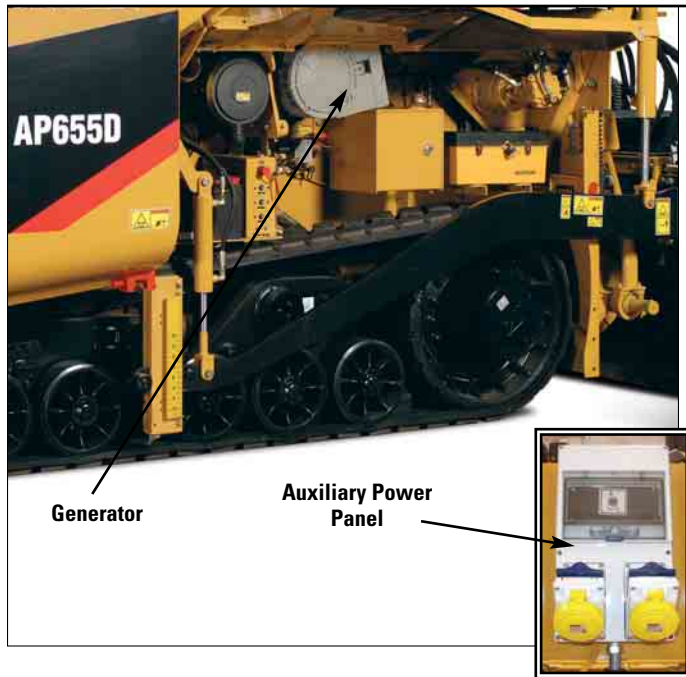

Industrial, Single-Phase A.C. Generator. The tractor-mounted generator provides 25 kW of power at 60 Hz for the electric screed heat and the auxiliary power panel. Circuit breaker protection, internal electronic voltage regulation and a dual bearing design provide reliability.

Choices Available (Belt or Hydraulic Driven). The belt-driven generator provides full power with a *variable frequency* when the engine speed increases above 1275 rpm.

The hydraulic-driven generator provides full power with a *fixed frequency* of 60 Hz when the engine speed increases above 1275 rpm.

Optional Auxiliary Power Panel. The power panel provides 4 kW of power for auxiliary lighting and job site work tools. The panel includes choice of two 240 V or two 120 V receptacles, protected for ground fault circuit interrupt (GFCI). Activating the “Tool Mode” switch provides power at 50 Hz for frequency sensitive tools.

Screed That Delivers Quality

AS4251C double width hydraulic power extendible asphalt screed provides even material flow and unparalleled stability that result in smooth, high quality mats.



The AS4251C screed paves from 2550 mm to 5000 mm. With mechanical extensions added to both sides, maximum paving width is 8000 mm.

AS4251C Screed. The screed is available with variable frequency tamper and vibrators and with LPG or electric heating system. The screed control panels include material feeding controls for easy ground crew usage.

Tamper and Vibrator. Automatically operated when the AP655D advances following a preset ramp. Tamper starting and stopping ramps are adjustable in order to maintain an optimum mat finish. The AS4251C screed is equipped with electronic ignition, automatic and independent adjustment of the smoothing plate temperature for central and each mobil plate.

LPG Heating System. The system provides high efficiency burners and optimum thermostatic temperature control.

Electric Heating System. The system provides a tractor-mounted generator, replaceable heating elements and operator friendly controls providing a cleaner environment. Feature & benefits include simple operation, fast heat-up time, multi-zone heating elements and thermostatic control of all screed plates. Heavy-duty, user-friendly screed heating control unit with self-diagnostic control is positioned at the rear of the machine for easy ground crew usage.

Serviceability Features That You've Come to Expect

Simplified service means more time spent paving and less time spent on maintenance.



Advisor Monitoring System (AMS). The Advisor display lists diagnostic fault codes for machine functions making troubleshooting quick and easy.

Manual Overrides. The hydraulic pump solenoids incorporate manual overrides to assist troubleshooting procedures.

Large Access Doors and Panels. Preventative maintenance points can be accessed through the large swing open access doors and panels.

Remote Lubrication Points. Lubrication points are grouped in order to make routine service quick and easy.

Color-Coded and Numbered Electrical Wiring. Troubleshooting is efficient and simplified with the color-coded and numbered wiring.

Optional Equipment

Caterpillar offers many options that allow the paver and screed to be configured to your specific application. Contact your dealer for more details.

Tractor Options

- Auger and Mainframe Extensions
- Auxiliary Power Panel
- CE Certificate
- Decelerator Pedals
- Ecological Washdown System
- Folding Operator's Station Canopy
- Generator (Belt or Hydraulic Driven)
- Italian/German Road Homologation
- Lights (High Intensity Discharge and Halogen)
- Power Folding Hopper Apron
- Proportional Paddle Sensor
- Sonic Feeder Sensors
- Steering Guide
- Uptime Kit
- Ventilation System
- Warning Beacon

Controls and Grade References

- Automatic Grade and Slope Control
- Non-Contacting Sonic Grade Sensor
- Contacting Grade Sensor
- Outboard Leveler, 9.15 m and 12.2 m
- Inboard Leveler
- Sonic Averaging Beam
- Rigid Ski, 9.15 m and 12.2 m

Screed Options

- Extensions for: 5.5 m – 6.5 m – 7 m – 8 m
- Foldable End Gates
- Power Crown Adjuster
- Tamper, Vibrator and Counterbalance Display Control

Engine

Six cylinder Caterpillar C6.6 with ACERT™ Technology, turbocharged air-to-air after-cooled diesel engine. Meets European EU Stage IIIA engine emission regulations.

Gross Power	2200 rpm
SAE J1995	129.5 kW/176 hp
Net Power	2200 rpm
ISO 9249	121.9 kW/165.8 hp
EEC 80/1269	121.9 kW/165.8 hp
Bore	105 mm
Stroke	127 mm
Displacement	6.6 liters

- All engine horsepowers are metric including front cover.
- Net power ratings are tested at the reference conditions for the specified standard.
- Net power advertised is the power available at the flywheel when the engine is equipped with alternator, air cleaner, muffler and fan.
- Derating is not required up to an altitude of 3000 m.

Suspension

The high-speed Mobil-trac™ undercarriage consists of a durable, high-strength rubber belt with a thick outer cover that includes five internal layers of flexible steel cable. The track is 3023 mm long and 457 mm wide. Drive traction is provided by a hydraulic tensioning cylinder with accumulator that maintains friction between the belt and the drive wheels. Rubber-coated steel mid-wheels provide smooth ride and high traction efficiency by distributing weight over the entire length of the belt.

The steel track undercarriage consists of four 241 mm diameter track rollers, a special rear, four roller 152 mm diameter bogey, and two 152 mm diameter single roller return idlers per side. Rollers are bogied in pairs and each pair is articulated for optimum leveling capability. Rollers ride on Caterpillar® D3 track rails. Track rails are sealed, lubricated and include a split master link for quick track removal and installation. Track tensioning is provided by a parallel link swing arm design that provides constant hydraulic pressure. Track tension is maintained without manual adjustment. Recoil forces are controlled by check and relief valves.

Track Base

MTS undercarriage	3020 mm
Steel Track undercarriage	3060 mm

Transmission

The Mobil-trac™ drive system utilizes two dual path hydrostatic pumps and two fixed displacement motors. The pumps are infinitely variable with electronic displacement controls (EDC) for steering and speed. Single speed motors drive two speed planetary gear boxes to provide two propel ranges. The drive system is equipped with two switches located at the operator's station control console. The two switches are used as manual overrides and are directly linked to EDC's. The steel track drive system utilizes two dual path hydrostatic pumps and two variable displacement motors. The pumps are infinitely variable with electronic displacement controls (EDC) for steering and speed. The two speed motors drive single speed planetary gear boxes to provide two propel ranges. The drive system is equipped with two switches located at the operator's station control console. The two switches are used as manual overrides and are directly linked to EDC's.

Speeds (forward and reverse)

Paving

Mobil-trac	0-25 mpm
Steel Track	0-25 mpm

Travel

Mobil-trac	14.8 km/h
Steel Track	5.3 km/h

Brakes

Primary Brake Features

- A closed-loop hydrostatic system provides dynamic braking during normal operation.

Parking Brake Features

- Safety and parking brakes system includes a spring applied, hydraulically released brake which is actuated by a switch on the operator's station control console.

Steering

Hydraulic power assist steering system provides smooth, low effort steering by means of a steering wheel. Electric over hydraulic dual path differential steering assures precise machine control. Steering commands are independent of propel speed. Three steering modes including pave, travel and maneuver are selectable at the operator's control console.

Electrical System

The 24-volt DC electrical system is designed for improved durability, reliability and ease of service. Two 12-volt batteries with 1400 cranking amps each and a 80-amp alternator are used in the system. Wires are loomed with vinyl-coated nylon braid to improve the overall integrity of the electrical system and to protect against abrasion.

Dimensions

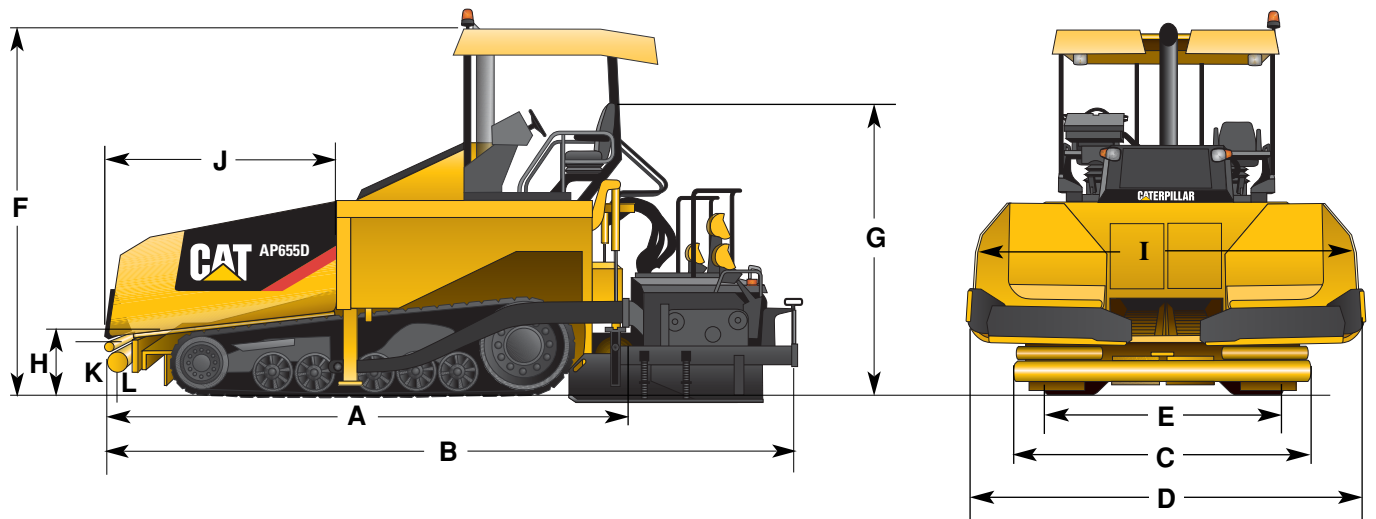

	mm
A Tractor length with push roller	4950
B Length with push roller and screed	6160
C Transport width with screed end gates (hopper raised)	2720
Transport width without screed end gates (hopper raised)	2500
D Tractor operating width (hopper lowered)	3306
E Track gauge width	2200
F Operating height with canopy	3840
G Transport height with canopy, fumes stack and seat lowered	2920

	mm
H Truck dump height (at hoppers)	
MTS undercarriage	605
Steel Track undercarriage	593
I Truck entry width (at hoppers)	3200
J Hopper length	1960
K Push roller height	533
L Clearance	260
Hopper capacity (with conveyor tunnels) – m ³	6.5
Discharge height at center	
MTS undercarriage	577
Steel Track undercarriage	566
Augers diameter	406

Service Refill Capacities

	Liters
Fuel tank	290
Cooling system (total)	30
Engine oil w/filter	14
Hydraulic oil tank	218
Washdown spray system	38

Weights

	kg
Operating Weights*	
MTS/Steel Track undercarriage	19 165
Shipping Weights**	
Tractor only	15 050
Tractor with screed	18 890

Weights shown are approximate and include:

* 75 kg operator, with canopy, fuel tank 50%, leveling system, standard width screed (2.55-5 m).

** base machine, canopy lowered, fuel tank 10%, manual apron, standard screed end gates.

AP655D Asphalt Paver

For more complete information on Cat products, dealer services, and industry solutions, visit us on the web at www.cat.com

Materials and specifications are subject to change without notice. Featured machines in photos may include additional equipment. See your Caterpillar dealer for available options.

© 2007 Caterpillar -- All rights reserved

HEHG3611 (08/2007) hr

CAT, CATERPILLAR, their respective logos, "Caterpillar Yellow" and the POWER EDGE trade dress as well as corporate and product identity used herein, are trademarks of Caterpillar and may not be used without permission.

CATERPILLAR[®]