

12M2/ 12M2 AWD

Motor Graders



Engine

Engine Model	Cat® C9.3 ACERT™	
Base Power (1st gear) – Net	129 kW	173 hp
Base Power (1st gear) – Net (Metric)		176 hp
VHP Plus range – Net	129-166 kW	173-223 hp
VHP Plus range – Net (Metric)		176-226 hp
AWD range – Net	136-181 kW	183-243 hp
AWD range – Net (Metric)		186-246 hp

Emissions

U.S. Tier 4 Interim/EU Stage IIIB

Moldboard

Blade width	3.7 m	12 ft
-------------	-------	-------

Weights

Operating Weight, typically equipped	19 224 kg	42,383 lb
--------------------------------------	-----------	-----------

Weights – AWD

Operating Weight, typically equipped	20 116 kg	44,349 lb
--------------------------------------	-----------	-----------

Features

Operator Station

A revolutionary cab design provides unmatched comfort, visibility and ease of use, making the operator more confident and productive.

Engine and Power Train

Combining power management with ACERT™ Technology delivers maximum power and efficiency while reducing the environmental impact. M Series 2 Motor Graders meet U.S. Tier 4 Interim/EU Stage IIIB emission standards.

Structures, Drawbar, Circle and Moldboard

Durable structures with fast and simple DCM adjustments deliver precise material control while lowering operating costs.

Hydraulics

The M Series 2 Motor Grader electro-hydraulics enable advanced machine controls with precise and predictable movements.

Integrated Technologies

Full systems integration optimizes machine performance and availability.

All Wheel Drive (AWD)

Maximum productivity with six powered wheels. Hydrostatic Mode powers only the front wheels, perfect for precise finish work. Steering Compensation adjusts the outside front tire speed for tighter turns, less scuffing and tire wear, and improved control.

Contents

Operator Station.....	3
Steering and Implement Controls	4
Emissions Technology.....	5
Engine	5
Power Train.....	6
Structures and DCM.....	7
“Smart” Machine Systems.....	8
All-Wheel Drive (AWD)	8
Hydraulics	9
Integrated Technologies.....	10
Work Tools and Attachments.....	11
Safety	12
Customer Support.....	13
Sustainability	13
12M2/12M2 AWD Motor Grader Specifications	14
12M2/12M2 AWD Standard Equipment.....	18
12M2/12M2 AWD Optional Equipment	19



The M Series 2 continues the legacy of quality already established by Cat® Motor Graders. The extensive validation program, combined with improvements to the manufacturing process, allows Caterpillar to further enhance our quality.

The end result of this development process is a motor grader line with breakthrough technologies, tested in the field and built around real applications and real customer needs. M Series 2 Motor Graders meet U.S. EPA Tier 4 Interim/EU Stage IIIB emission standards.



Operator Station

Comfort, productivity, advanced technology.

Visibility

Angled cab doors, a tapered engine enclosure and patented sloped rear window assure excellent visibility to the work area.

Maximum Control, Maximum Comfort

Caterpillar has built the most comfortable cab in the industry, replacing the control levers and steering wheel with two joystick controls, and lengthening the cab for more leg room. Machine design features, like angled doors, provide excellent visibility.

Operator Comfort

The Cat Comfort Series suspension seat and arm/wrist rests are fully adjustable for improved comfort and productivity. Extra leg room, easy-to-reach long-life rocker switches and revolutionary joystick controls make this the most comfortable cab in the industry.

Standard HVAC system

The high capacity system dehumidifies and pressurizes the cab, circulates fresh air, seals out dust and keeps windows clear.

Low Interior Sound and Vibration Levels

Multiple isolation mounts along with relocated hydraulic pump and valves significantly improve operator comfort and productivity.

In-Dash Instrument Cluster

Easy-to-read, high-visibility gauges and warning lamps keep the operator aware of critical system information.

Steering and Implement Controls

Unprecedented precision and ease of operation.



Ease of Operation

Two electro-hydraulic joysticks require up to 78% less hand and wrist movement than conventional lever controls for greatly enhanced operator comfort and efficiency. The intuitive control pattern allows both new and experienced operators to quickly become productive.

Electronically adjustable control pods help position joysticks for optimal comfort, visibility and proper operation.

Joystick Functions

- The left joystick primarily controls the machine direction and speed including steering, articulation, return-to-center, wheel lean, gear selection, left moldboard lift cylinder and float.
- The right joystick primarily controls drawbar, circle and moldboard functions including right moldboard lift cylinder and float, moldboard slide and tip, circle turn, drawbar center shift, electronic throttle control and manual differential lock/unlock.

Intuitive Steering Control

Joystick lean angle mirrors the steer tires' turning angle. A brake tensioning system holds the joystick in position until the operator moves it. The steering control automatically reduces steering sensitivity at higher ground speeds for comfortable and predictable control.

Electronic Throttle Control

Provides easy, precise and consistent throttle operation. An automatic/manual mode switch offers flexibility for different applications and operator preferences.

Articulation Return-to-Center

Automatically returns the machine to a straight frame position from any angle with the touch of a button.

Auxiliary Pod and Ripper Control (Optional)

Ergonomically positioned to allow simple, comfortable operation for the multiple hydraulic options.

- Four fingertip controls and a mini joystick maximize control of up to six hydraulic circuits. Individual functions can be programmed with Electronic Technician (Cat ET). The auxiliary hydraulic pod is provided when the machine is configured with three or more auxiliary functions.
- Infinitely variable roller switches provide precise control of the rear ripper and/or front lift group (when equipped).



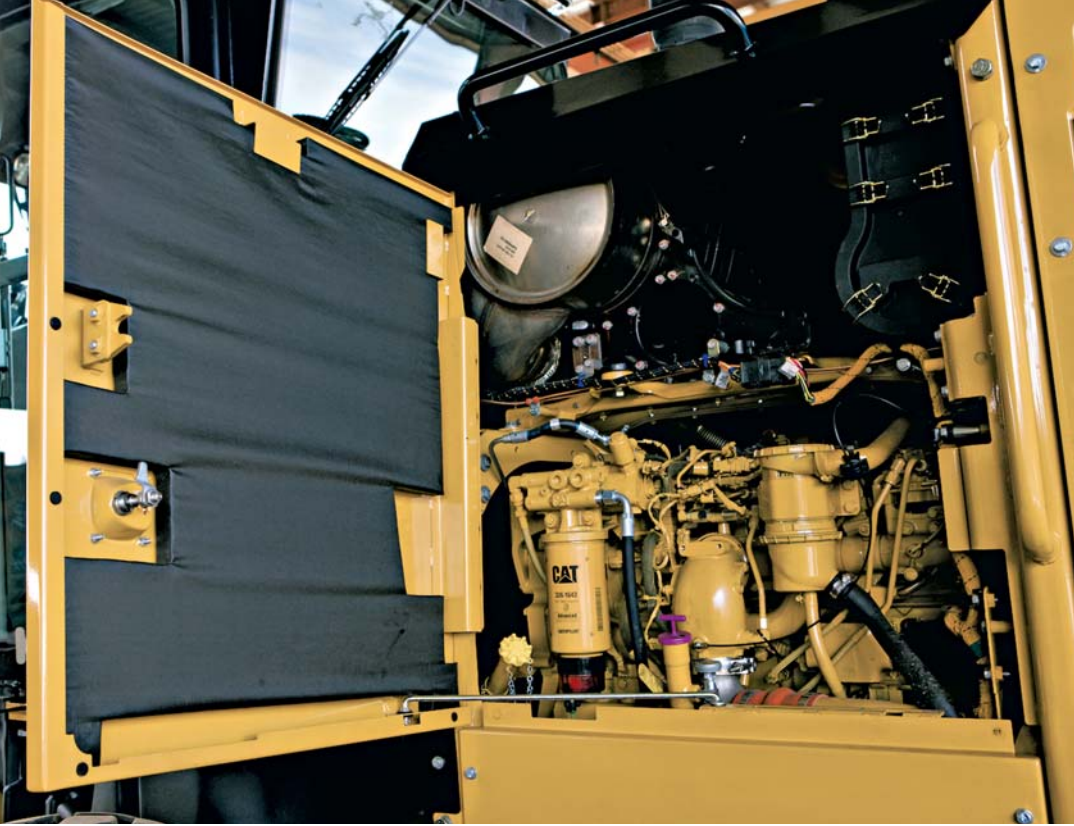

Engine

Power and reliability.

A Cat C9.3 ACERT™ engine and Cat Clean Emissions Module deliver the performance and efficiency that customers demand, while meeting Tier 4 Interim/Stage IIIB emission standards.

The C9.3 ACERT engine has superior torque and lugging capability to pull through sudden, short-term loads and maintain consistent, desirable grading speeds to get work done faster without downshifting. The High Pressure Common Rail Fuel System improves precision and control with full electronic injection that boosts performance and reduces soot.

Hydraulic Demand Fan

The hydraulic demand fan automatically adjusts cooling fan speed according to engine cooling requirements. This reduces demand on the engine, putting more horsepower to the ground and improves fuel efficiency. Swing-out design allows easy access to cooling cores and reduces clean out time.

Emissions Technology

Reliable, integrated solutions.

Cat NOx Reduction System

The Cat NOx Reduction System captures and cools a small quantity of exhaust gas, then routes it into the combustion chamber where it drives down combustion temperatures and reduces NOx emissions.

Aftertreatment Technologies

To meet Tier 4 Interim/Stage IIIB emission standards and beyond, Cat aftertreatment components have been designed to match application needs. System components include a **Diesel Oxidation Catalyst (DOC)**, which uses a chemical process to convert regulated emissions in the exhaust system, and a **Diesel Particulate Filter (DPF)** that traps particulate matter that is carried into the exhaust stream.

The DOC, DPF and Cat Regeneration System are contained in a Caterpillar designed Clean Emission Module (CEM) that protects the components, minimizes the aftertreatment footprint and simplifies maintenance.

Cat Regeneration System

The Cat Regeneration System is designed to work transparently, without any interaction needed from the operator. Under most operating conditions, engine exhaust is hot enough to oxidize soot through passive regeneration. If supplemental regeneration is needed, the Cat Regeneration System elevates exhaust gas temperatures to remove soot in the Diesel Particulate Filter (DPF). This is a process that happens automatically, but the operator can initiate the cycle when convenient or interrupt regeneration as needed. A soot level monitor can be viewed on the Cat Messenger screen and regeneration indicator lights are integrated into the front console.



Power Train

Maximum power to the ground.

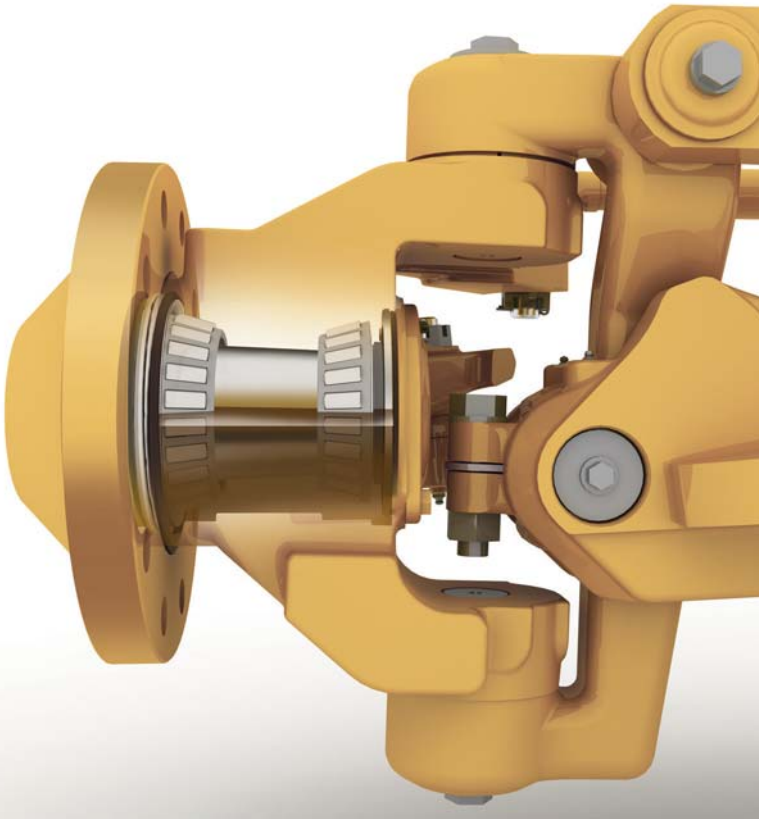

Automatic Differential Lock

Unlocks the differential during a turn, re-locks when straight, for easier operation and lower power train protection.

Front Axle

The Cat sealed spindle keeps bearings free from contaminants and lubricated in a light weight oil. The Cat “Live Spindle” design places the larger tapered roller bearing outboard where the load is greater, extending bearing life.

Inching Pedal

Allows precise control of machine movements and excellent modulation, critical in close-quarter work or finish grading.

Smooth Shifting Transmission

Several key innovations ensure smooth, powerful shifts.

- Full Electronic Clutch Pressure Control (ECPC) system optimizes inching modulation for smooth shifts and directional changes, reducing stress on gears.
- Controlled Throttle Shifting helps to smooth directional and gear changes without using the inching pedal.
- Load Compensation ensures consistent shift quality regardless of blade or machine load.
- This standard feature automatically shifts the transmission at optimal points so the operator can focus on the work to help improve safety, productivity and ease of operation.
- Power Shift Countershaft Transmission and the Cat C9.3 engine maximize power to the ground. Eight forward/six reverse gears optimize productivity.
- Engine Over-Speed Protection prevents downshifting until an acceptable safe travel speed has been established.

Bolt-On Modular Rear Axle

Improves serviceability and contamination control with easy access to differential components.

Hydraulic Brakes

Hydraulically actuated, oil bathed, multi-disc service brakes at each tandem wheel (1) offer the industry’s largest total brake surface area (2) for dependable stopping power and long brake life. The brake wear indicator/compensator system (3) maintains brake performance and indicates brake wear without disassembly, for fast servicing and longer brake service life. The spring-applied, hydraulically released multi-disc parking brake, sealed and oil-cooled for long life and low service, is integrated into the Operator Presence System to prevent unintended machine movement.

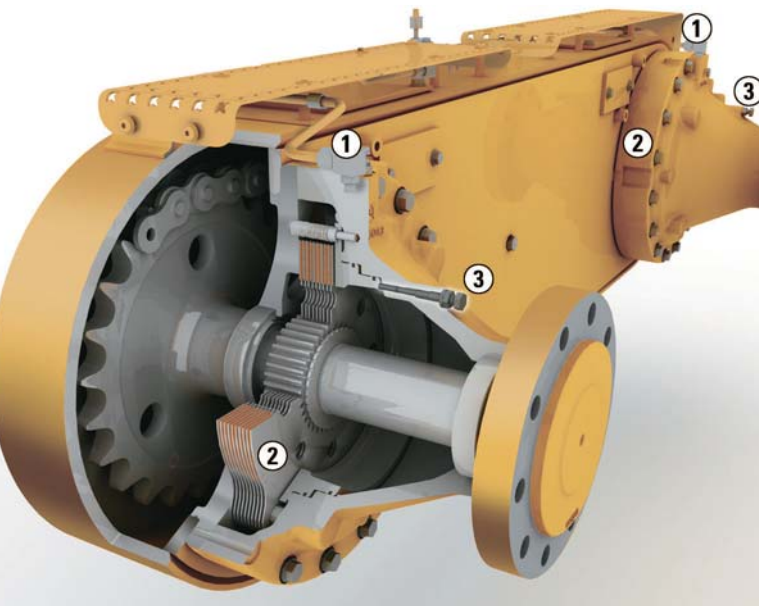

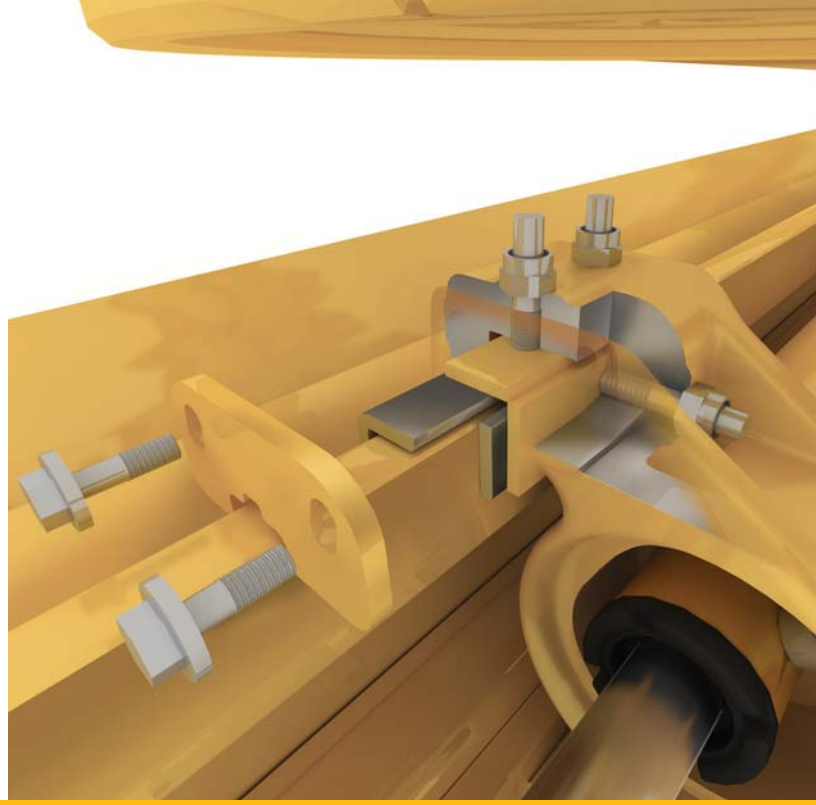
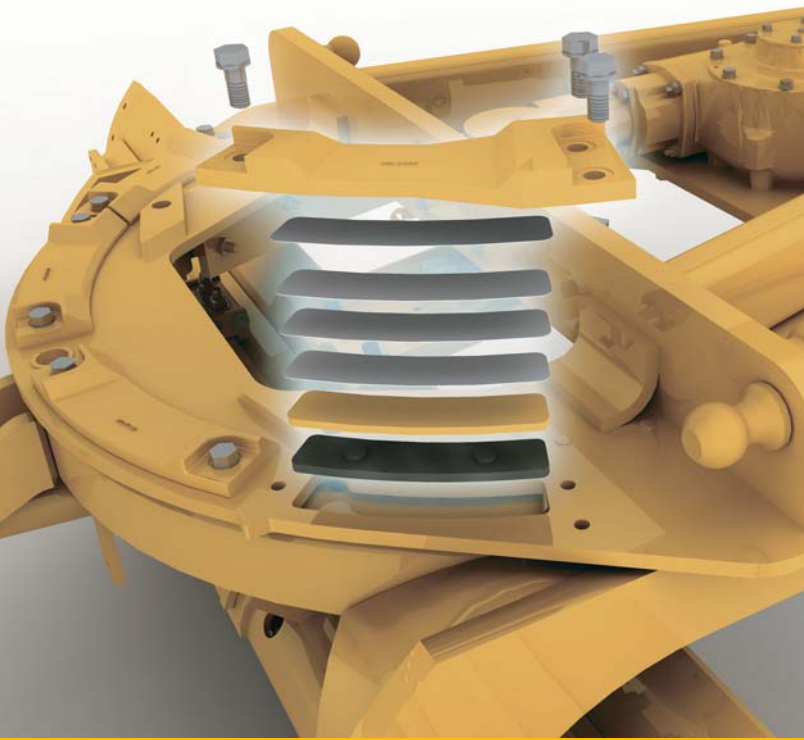

Structures and DCM

Service ease and precise blade control.

Heavy Duty Durability

The frame, drawbar and one-piece forged steel circle are designed for durability in heavy duty applications. The strong A-frame drawbar uses a durable tubular design. The front 240° of circle teeth are hardened to reduce wear and ensure component reliability.

Articulation Hitch

A large tapered roller bearing at the lower pivot carries loads evenly and smoothly. Sealed to prevent contamination, a locking pin prevents articulation for safety during service or transport.

Aggressive Blade Angle

Allows material to roll more freely along the blade, particularly dry materials or cohesive soils. Better material control gets the job done faster, requires less power and saves fuel.

Fast, Easy Adjustment Means Tight Components

Shims and patented top-adjust wear strips are easy to add or replace, dramatically reducing downtime and operating costs. Durable nylon composite wear inserts maximize circle torque and component life. Sacrificial brass wear strips between the blade mounting group and moldboard can be replaced easily. Shimless Moldboard Retention System uses vertical and horizontal adjusting screws to keep moldboard wear strips aligned for reduced blade chatter, precise blade control and dramatic reductions in service time.

Moldboard

Heat-treated rails, hardened cutting edges and end bits, and heavy duty bolts assure reliability and long service life. The link bar allows extreme moldboard positioning for bank sloping, ditch cutting and cleaning.



“Smart” Machine Systems

Advanced diagnostics.

Sharing key data among systems helps optimize machine performance and aids serviceability.

- Cat Messenger, combined with full systems integration, enhances diagnostic capability. Machine system errors are displayed in both text and fault codes for quick analysis of critical data.
- Electronic Technician (Cat ET) lets service technicians access stored diagnostic data and configure machine parameters through the Cat Data Link.
- Low Battery Elevated Idle raises idle speed when low system voltage is detected, ensuring adequate system voltage and improving battery reliability.
- Automatic Engine Deration protects the engine and aftertreatment by automatically lowering engine torque output and alerting the operator if critical conditions are detected.

All-Wheel Drive (AWD)

Expanded machine versatility.

All Wheel Drive (AWD)

The AWD arrangement utilizes dedicated left and right pumps for precise hydraulic control. The infinitely variable pumps and motors maximize torque in each gear. This delivers the most power to the ground in the industry and increases productivity.

Maximum Net Power

When AWD is engaged, flywheel horsepower is automatically increased up to an additional 45 kW (60 hp) from base power. This offsets the parasitic losses and maximizes net power to the ground for increased productivity.

Hydrostatic Mode

Standard with AWD, this mode disengages the transmission and provides hydraulic power to the front wheels only. The ground speed is infinitely variable between 0-8 km/h (0-5 mph), perfect for precise finish work.

Steering Compensation

Cat Steering Compensation System enables a “powered turn” by adjusting the outside front tire speed up to 50% faster than the inside tire. The result is improved control, less damage to surfaces and a dramatic reduction of turning radius in poor underfoot conditions.





Hydraulics

Advanced machine control.

Advanced Electro-Hydraulic System

Incorporates a state-of-the-art electro-hydraulic system as the foundation for revolutionary changes in machine and advanced joystick controls.

Blade Float

Allows the blade to move freely under its own weight. By floating both cylinders, the blade can follow the contours of the road, especially useful when removing snow. Floating only one cylinder permits the toe of the blade to follow a hard surface while the operator controls the slope with the other lift cylinder.

Independent Oil Supply

Large, separate hydraulic oil supplies prevent cross-contamination and provide proper oil cooling, which reduces heat build-up and extends component life.

Load Sensing Hydraulics (PPPC)

The proven load-sensing system and the advanced Proportional Priority Pressure-Compensating (PPPC or “triple P – C”) electro-hydraulic valves provide superior implement control and enhanced machine performance in all applications. Continuously matching hydraulic flow/pressure to power demands creates less heat and reduces power consumption.

- Consistent, Predictable Movement – PPPC valves have different flow rates for the head (red) and rod ends (blue) of the cylinder, ensuring consistent extension and retraction speeds.
- Balanced Flow – Hydraulic flow is proportioned so all implements operate simultaneously with little effect on the engine or implement speeds.

Integrated Technologies

Solutions to make work easier and more efficient.



Cat Grade Control Cross Slope

Cross Slope is a factory installed machine control and guidance system that allows for accurate and real-time positioning of the moldboard without off-machine infrastructure. Harnesses, sensors and the in-cab display are fully integrated into the machine so the system is ready to work from the factory. The system helps the operator more easily achieve the desired cross slope by automating one end of the blade. The system also helps save time and materials so that even less experienced operators can achieve better results, more quickly. The system is designed for easy scalability, supporting all two- and three-dimensional upgrades to be fully compatible with all AccuGrade™ kits.

AccuGrade Ready Option

Optional factory-installed brackets and hardware make the grader ready for dealer installation of the AccuGrade grade control system. Installation is simplified, and integration of the components provides greater protection to enhance system reliability.

Cat AccuGrade

AccuGrade is a dealer-installed blade control system which enables operators to cut and fill to grade with increased accuracy, minimizing the need for traditional survey stakes and grade checkers. AccuGrade includes Cross Slope, Sonic, Laser, Global Navigation Satellite System (GNSS) and/or Universal Total Station (UTS) technologies to automatically control the blade. In-cab displays show precise elevation and real-time cut/fill information. More accurate blade positioning helps operators get to grade faster, with fewer passes than ever before. The AccuGrade System significantly improves grading productivity and accuracy by as much as 50 percent over conventional methods.

Cat Product Link*

Remote monitoring with Product Link improves overall fleet management effectiveness. Product Link is deeply integrated into machine systems. Events and diagnostic codes, as well as hours, fuel, idle time and other detailed information are transmitted to a secure web based application, VisionLink™. VisionLink includes powerful tools to convey information to users and dealers, including mapping, working and idle time, fuel level and more.

**Product Link licensing not available in all areas. Please consult your Cat dealer for availability.*



Work Tools and Attachments

Equip your machine for the job.

Moldboard Options

Standard 3.7 m (12 ft) or optional 4.3 m (14 ft). Left and right side extensions are also available.

Ground Engaging Tools (GET)

A variety of tools are available from Cat Work Tools, including cutting edges, graderbits and end bits, all designed for maximum service life and productivity.

Front Mounted Groups

A front mounted push plate/counterweight or front lift group are available. The front lift group can be combined with a front dozer blade or front scarifier for added versatility.

Rear Ripper/Scarifier

Made to penetrate tough material fast and rip thoroughly for easier movement with the moldboard. The ripper includes three shanks (with holders for five). Nine scarifier shanks can also be added for additional versatility.

Snow Removal Work Tools

Multiple snow plow, snow wing and mounting options increase machine versatility and utilization throughout the year.

Safety

Protect your most valuable resource.



Designed with Protection in Mind

Features are designed to enhance operator and job site safety, such as drop-down rear lights and a rearview camera. Among many standard safety features are laminated glass, back-up lights, and perforated tandem walkways and grab rails.

Operator Presence System

The parking brake remains engaged and hydraulic implements disabled until the operator is initially seated and the machine is ready for operation.

Secondary Steering System

Automatically engages an electric hydraulic pump in case of a drop in steering pressure, allowing the operator to steer the machine to a stop.

Hydraulic Lockout

A simple switch located in the cab disables all implement functions while still providing machine steering control. This safety feature is especially useful while roading.

Brake Systems

Brakes are located at each tandem wheel to eliminate braking loads on the power train. Redundant brake systems utilize accumulators to enable stopping in case of machine failure, further increasing operational safety.

Circle Drive Slip Clutch

This standard feature protects the drawbar, circle and moldboard from shock loads when the blade encounters an immovable object. It also reduces the possibility of abrupt directional changes in poor traction conditions.

Blade Lift Accumulators (Optional)

This optional feature uses accumulators to help absorb impact loads to the moldboard by allowing vertical blade travel. Blade lift accumulators help reduce unnecessary wear and also help reduce impact loading for enhanced operator safety.

Rearview Camera (Optional)

Visibility is further enhanced with an optional Work Area Vision System (WAVS) through a 178 mm (7 in) LCD color monitor in the cab. Developed specifically for rugged applications, this durable camera improves productivity and increases operator awareness of surroundings.

Front and Rear Fenders (Optional)

To help reduce objects flying from the tires, as well as build-up of mud, snow and debris, optional fenders can be added.



Customer Support

Unparalleled worldwide support.

Renowned dealer service

From helping you choose the right machine to financing and ongoing support, your Cat dealer provides the best in sales and service.

Manage your costs with preventive maintenance programs like S•O•SSM analysis, Coolant Sampling and guaranteed maintenance contracts.

Stay productive with best-in-class parts availability. Your Cat dealer can even help boost your profits with operator training.

And when it's time for component replacement, your Cat dealer can help you save even more. Genuine Cat Remanufactured parts carry the same warranty and reliability as new products at savings of 40 to 70 percent for power train and hydraulic components.

Sustainability

Thinking generations ahead.

M Series 2 Motor Graders are designed to benefit your business and reduce emissions.

- Cat engine and aftertreatment meet U.S. Tier 4 Interim/ EU Stage IIIB emission standards.
- Integrated machine systems and technologies improve productivity for greater accuracy, lower fuel use and reduced machine wear.
- Replaceable wear parts save maintenance time and cost, and extend major component life.
- Major structures and components are built to be rebuilt, reducing waste and replacement costs.
- Extended service intervals reduce maintenance time/cost and waste.
- A variety of safety features help safeguard operators and others on the job site.



12M2/12M2 AWD Motor Grader Specifications

Engine		
Engine Model	Cat® C9.3 ACERT™	
Emissions	U.S. Tier 4 Interim/ EU Stage IIIB	
Base Power (1st gear) – Net	129 kW	173 hp
Base Power (1st gear) – Net (Metric)	176 hp	
VHP Plus range – Net	129- 166 kW	173- 223 hp
VHP Plus range – Net (Metric)	176- 226 hp	
AWD range – Net	136- 181 kW	183- 243 hp
AWD range – Net (Metric)	186- 246 hp	
Displacement	9.3 L	567.5 in ³
Bore	115 mm	4.5 in
Stroke	149 mm	5.9 in
Torque rise	50%	
Max torque	1138 N·m	839 lb-ft
Speed @ rated power	2,100 rpm	
Number of cylinders	6	
Derating altitude	3048 m	10,000 ft
Hi Ambient – Fan speed		
Standard	1,400 rpm	
Max	1,550 rpm	
Min	500 rpm	
Standard Capability	43° C	109° F
Hi Ambient Capability	50° C	122° F

VHP Plus – gear		
1F, Net	129 kW	173 hp
2F, Net	136 kW	183 hp
3F, Net	144 kW	193 hp
4F, Net	151 kW	203 hp
5F, Net	155 kW	208 hp
6F, Net	159 kW	213 hp
7F, Net	163 kW	218 hp
8F, Net	166 kW	223 hp

- Net power is tested per ISO 9249, SAE J1349, and EEC 80/1269 Standards in effect at the time of manufacture.
- Net power advertised is the power available at rated speed of 2,100 rpm, measured at the flywheel when engine is equipped with fan running at minimum speed, air cleaner, muffler and alternator.
- No engine derating required up to 3048 m (10,000 ft).
- Power as declared per ISO 14396
Rated rpm 2,100
VHP+ = 167 kW (224 hp)
AWD = 182 kW (244 hp)
- All non-road U.S. EPA Tier 4, European Union (EU) Stage IIIB and IV, and Japan (MLIT) Step IV certified diesel engines are required to use:
 - Ultra Low Sulfur Diesel (ULSD) and Sulfur-Free fuels that are 15 ppm (mg/kg) sulfur or less.
 - Cat DEO-ULS™ or oils that meet the Cat ECF-3, API CJ-4, and ACEA E9 specification.

Power Train	
Forward/ Reverse Gears	8 Fwd/6 Rev
Transmission	Direct Drive, Powershift
Brakes	
Service	Multiple Oil Disc
Service, surface area	23 000 cm ² 3,565 in ²
Parking	Multiple Oil Disc
Secondary	Dual Circuit

Hydraulic System		
Circuit type	Parallel	
Pump type	Variable Piston	
Pump output	210	55.7
	L/min	gal/min
Maximum system pressure	24 150 kPa	3,500 psi
Reservoir tank capacity	60 L	15.85 gal
Standby Pressure	4200 kPa	609 psi
• Pump output measured at 2,150 rpm		

Operating Specifications		
Top Speed		
Fwd.	46.6 km/h	29.0 mph
Rev.	36.8 km/h	22.9 mph
Turning radius, outside front tires	7.6 m	24 ft 10 in
Steering range – left/right	47.5°	
Articulation angle – left/right	20°	
Fwd.		
1st	4.1 km/h	2.5 mph
2nd	5.5 km/h	3.4 mph
3rd	8.0 km/h	5.0 mph
4th	11.0 km/h	6.9 mph
5th	17.1 km/h	10.6 mph
6th	23.3 km/h	14.5 mph
7th	32.0 km/h	19.9 mph
8th	46.6 km/h	29.0 mph
Rev.		
1st	3.2 km/h	2.0 mph
2nd	6.0 km/h	3.7 mph
3rd	8.7 km/h	5.4 mph
4th	13.5 km/h	8.4 mph
5th	25.3 km/h	15.7 mph
6th	36.8 km/h	22.9 mph
Calculated with no slip and 14R24 tires.		

Service Refill

Fuel Capacity	416 L	110 gal
Cooling system	56 L	14.8 gal
Hydraulic system		
Total	100 L	26.4 gal
Tank	64 L	16.9 gal
Engine Oil	30 L	7.9 gal
Trans./Diff./ Final Drives	65 L	17.2 gal
Tandem housing (each)	64 L	16.9 gal
Front wheel spindle bearing housing	0.5 L	0.13 gal
Circle drive housing	7 L	1.8 gal

Frame

Circle		
Diameter	1530 mm	60.2 in
Blade beam thickness	40 mm	1.6 in
Drawbar		
Height	152 mm	6 in
Width	76.2 mm	3 in
Thickness	12.7 mm	0.5 in
Front-top/bottom plate		
Width	305 mm	12.0 in
Thickness	22 mm	0.87 in
Front frame structure		
Height	321 mm	12.6 in
Width	255 mm	10 in
Front axle		
Height to center	600 mm	23.6 in
Wheel lean, left/right	18°	
Front axle – total oscillation per side	32°	

- Front-top/bottom plate – width tolerance
±2.5 mm (0.098 in)

Tandems

Height	506 mm	19.9 in
Width	210 mm	8.3 in
Sidewall thickness		
Inner	16 mm	0.63 in
Outer	18 mm	0.71 in
Drive chain pitch	50.8 mm	2 in
Wheel axle spacing	1522.8 mm	59.95 in
Tandem oscillation		
Front up	15°	
Front down	25°	

Moldboard

Blade width	3.7 m	12 ft
Moldboard		
Height	610 mm	24 in
Thickness	22 mm	0.87 in
Arc radius	413 mm	16.3 in
Throat clearance	166 mm	6.5 in
Cutting edge		
Width	152 mm	6 in
Thickness	16 mm	0.6 in
End Bit		
Width	152 mm	6 in
Thickness	16 mm	0.6 in
Blade Pull		
Base GVW	11 367 kg	25,060 lb
Max GVW	15 455 kg	34,072 lb
Base GVW (AWD)	16 057 kg	35,439 lb
Max GVW (AWD)	22 399 kg	49,381 lb
Blade Down Pressure		
Base GVW	7223 kg	15,923 lb
Max GVW	13 243 kg	29,196 lb
Base GVW (AWD)	8100 kg	17,857 lb
Max GVW (AWD)	13 243 kg	29,196 lb

Blade Range

Circle centershift		
Right	728 mm	28.7 in
Left	695 mm	27.4 in
Moldboard sideshift		
Right	660 mm	26 in
Left	510 mm	20.1 in
Maximum blade position angle	90°	
Blade tip range		
Forward	40°	
Backward	5°	
Maximum shoulder reach outside of tires		
Right	1978 mm	77.87 in
Left	1790 mm	70.5 in
Maximum lift above ground	480 mm	18.9 in
Maximum depth of cut	715 mm	28.1 in

Ripper

Ripping depth, maximum	426 mm	16.8 in
Ripper shank holders	5	
Ripper shank holder spacing	533 mm	21 in
Penetration force	9386 kg	20,693 lb
Pryout force	12 544 kg	27,655 lb
Machine length increase, beam raised	1031 mm	40.6 in

12M2/12M2 AWD Motor Grader Specifications

Scarifier		
Front, V-Type: Working width	1205 mm	47.4 in
Front, V-Type, 5 or 11 tooth		
Working width	1031 mm	40.6 in
Scarifying depth, maximum	467 mm	18.4 in
Scarifier shank holders	5/11	
Scarifier shank holder spacing	116 mm	4.6 in
Mid, V-Type		
Working width	1184 mm	46.6 in
Scarifying depth, maximum	292 mm	11.5 in
Scarifier shank holders	11	
Scarifier shank holder spacing	116 mm	4.6 in
Front, V-Type		
Scarifying depth, maximum	1031 mm	40.6 in
Scarifier shank holders	5/11	
Scarifier shank holder spacing	467 mm	18.4 in
Rear		
Working width	2133 mm	84 in
Ripping depth, maximum	426 mm	16.8 in
Scarifying depth, maximum	426 mm	16.8 in
Scarifier shank holders	9	
Scarifier shank holder spacing	267 mm	10.5 in

Weights		
Gross Vehicle Weight, base		
Total	16 849 kg	37,145 lb
Front axle	4208 kg	9,277 lb
Rear axle	12 640 kg	27,867 lb
Gross Vehicle Weight, max		
Total	24 888 kg	54,869 lb
Front axle	7715 kg	17,009 lb
Rear axle	17 173 kg	37,860 lb
Operating Weight, typically equipped		
Total	19 224 kg	42,383 lb
Front axle	5438 kg	11,989 lb
Rear axle	13 786 kg	30,394 lb

Weights – AWD		
Gross Vehicle Weight, base		
Total	17 841 kg	39,334 lb
Front axle	4719 kg	10,403 lb
Rear axle	13 123 kg	28,930 lb
Gross Vehicle Weight, max		
Total	24 888 kg	54,869 lb
Front axle	7715 kg	17,009 lb
Rear axle	17 173 kg	37,860 lb
Operating Weight, typically equipped		
Total	20 116 kg	44,349 lb
Front axle	5915 kg	13,040 lb
Rear axle	14 201 kg	31,309 lb

- Base operating weight calculated on standard machine configuration with 14.0R24 tires, full fuel tank, coolant, lubricants and operator.
- Typically equipped operating weight is calculated with push block, rear ripper/scarifier, and other equipment.

Standards	
ROPS/FOPS	ISO 3471/ISO 3499
Steering	ISO 5010
Brakes	ISO 3450, ISO 10265
Sound	ISO 6394; ISO 6395

- The static sound operator sound pressure level measured according to ISO 6394:2008 for a cab offered by Caterpillar, when properly installed, maintained and tested with doors and windows closed and engine cooling hydraulic fan at maximum speed is 73 dB(A).
- The dynamic spectator sound power level measured according to ISO 6395:2008 for the standard machine when equipped with optional sound suppression package and engine cooling hydraulic fan running at 70% of maximum speed, machine sound measured is less than 106 dB(A) for 12M2 and 107 dB(A) for 12M2 AWD, complying with EU 2000/14/EC requirement.

Dimensions

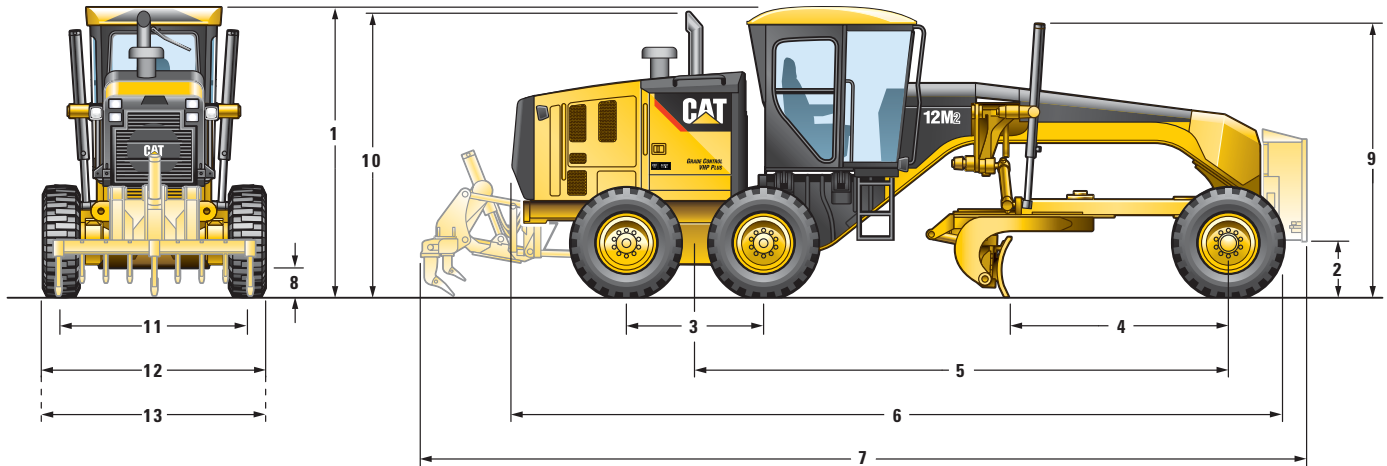

1	Height – Top of Cab	3287 mm	129.4 in
2	Height – Front Axle Center	600 mm	23.6 in
3	Length – Between Tandem Axles	1523 mm	60 in
4	Length – Front Axle to Moldboard	2557 mm	100.7 in
5	Length – Front Axle to Mid Tandem	6126 mm	241 in
6	Length – Front Tire to Rear of Machine	8898 mm	350.3 in
7	Length – Counterweight to Ripper	10 140 mm	399.2 in
8	Ground Clearance at Rear Axle	344 mm	13.5 in
9	Height to Top of Cylinders	3043 mm	119.8 in
10	Height to Exhaust Stack	3242 mm	127.6 in
11	Width – Tire Center Lines	2141 mm	84.3 in
12	Width – Outside Rear Tires	2581 mm	101.6 in
13	Width – Outside Front Tires	2581 mm	101.6 in

Optional Tire Arrangements

Wheel Group		Tires	Tire Arrangement Weight (Total – 6 Tires)	
10x24 MP	14.00R24	Michelin XGLA2 1 Star	1035 kg	2,276 lb
10x24 MP	14.0R24	Bridgestone VSW 1 Star	1222 kg	2,687 lb
10x24 MP	14.0R24	Bridgestone VKT 1 Star	1249 kg	2,747 lb
14x25 MP	17.5R25	Michelin XTLA 1 Star	1264 kg	2,780 lb
14x25 MP	17.5R25	Michelin XSNO Plus 1 Star	1137 kg	2,502 lb
14x25 MP	17.5R25	Michelin XHA 1 Star	1396 kg	3,071 lb
14x25 MP	17.5R25	Bridgestone VKT 1 Star	1463 kg	3,219 lb
14x25 MP	17.5R25	Bridgestone VSW 1 Star	1499 kg	3,297 lb

For a complete list of tire options, contact your local Cat dealer.

12M2/12M2 AWD Standard Equipment

Standard equipment may vary. Consult your Cat dealer for details.

POWER TRAIN

Air cleaner, dual stage, dry type, diesel, with automatic engine derate and automatic dust ejector, service indicator through Cat Messenger
Air-to-air after cooler (ATAAC)
Belt, serpentine, automatic tensioner
Brakes, oil disc, four-wheel, hydraulic
Demand fan, hydraulic, swing-out
Differential Lock/Unlock, Automatic
Drain, engine oil, ecology
Electronic over speed protection
Engine, C9.3 with ACERT Technology, Tier 4 Interim and Stage IIIB emission standards
Fuel tank, 416 L (110 gal), ground level access and sediment drain
Fuel-water separator
Muffler, underhood
Parking brake – multi-disc, sealed, oil-cooled
Priming pump, fuel
Rear axle, modular
Sediment drain, fuel tank
Tandem drive
Transmission, 8F/6R, power shift, direct drive
VHP Plus (Variable Horsepower)

ELECTRICAL

Alarm, back up
Alternator, 150 ampere, sealed
Batteries, maintenance free, heavy duty, 1,125 CCA
Breaker panel, ground accessible
Cab harness and electrical hydraulic valves
Electrical system, 24V
Grade Control Ready – Cab harness, software, electrical hydraulic valves, bosses and brackets
Lights, roof-mounted roading, reversing, LED stop and tail
Product Link Ready
Starter, electric

OPERATOR ENVIRONMENT

Accelerator
Air conditioning with heater
Arm and wrist rest, electronically adjustable
Articulation, automatic Return-to-Center
Ashtray and lighter
Cat® Messenger operator information system
Centershift pin indicator
Coat hook
Cup holder
Display, digital speed and gear
Doors, left and right side with wiper
Gauge, machine level
Gauge cluster (analog) – fuel, articulation, engine coolant temp, engine RPM, hydraulic oil temp, regen
Hour meter, digital
Joystick hydraulic controls
right/left blade lift with float position, circle drive, blade sideshift and tip, centershift, front wheel lean, articulation and power steering
Joystick, adjustable armrests
Joystick gear selection
Joystick hydraulic power steering
Ladders, cab, left and right side
Lights, night time cab
Mirror, inside rearview, wide angle
Power port, 12V
Radio Ready, Entertainment
ROPS cab, sound suppressed 70 dB(A)
Seat, cloth-covered, comfort suspension
Seat belt, retractable 76 mm (3 in)
Storage area for cooler/lunchbox
Throttle control, electronic
Windows, laminated glass:
fixed front with intermittent wiper side and rear (3)

FLUIDS

Antifreeze
Extended Life Coolant to -35°C (-30°F)

TIRES, RIMS AND WHEELS

Partial allowance for tires on 254×607 mm (10×24 in) multi-piece rims is included in the base machine price and weight

OTHER STANDARD EQUIPMENT

Accumulators, brake, dual certified
Anti-glare paint
Bumper, rear, integrated with hitch
CD ROM Parts Book
Clutch, circle drive slip
Cutting edges
 152×16 mm ($6 \times 5/8$ in) curved DH-2 steel
19 mm ($3/4$ in) mounting bolts
Doors (4), engine compartment, locking
Drawbar – 6 shoes, replaceable wear strips
Electrical hydraulic valves, hydraulic lines for base 8 functions
Endbits
16 mm ($5/8$ in) DH-2 steel
19 mm ($3/4$ in) mounting bolts
Fluid check, ground level
Frame, articulated, with safety lock
Ground level engine shutdown
Ground level fueling
Hammer (emergency exit)
Horn, electric
Hydraulic lines for base functions
Lockout, hydraulic implement (for roading and servicing)
Moldboard – $3658 \times 610 \times 22$ mm ($12 \text{ ft} \times 24 \text{ in} \times 7/8 \text{ in}$)
Mounting, cab roof accessories
Pump, hydraulic, high capacity, 98 cm^3 (6 in^3)
Radiator, cleanout access (both sides with swing doors)
Secondary steering
Serviceability, LH side
S•O•SSM ports: engine, hydraulic, transmission, coolant, fuel
Tandem walkway/guards
Tool box

12M2/12M2 AWD Optional Equipment

Optional equipment may vary. Consult your Cat dealer for details.

	kg	lb		kg	lb		kg	lb
ELECTRICAL			POWER TRAIN			WORK TOOLS/G.E.T.		
Alternator, 280 ampere	2	5	All Wheel Drive	590	1,300	Blade extension, left hand, 610 mm (2 ft)	113	249
Batteries:			Fuel tank, fast fill	14	31	Blade extension, right hand, 610 mm (2 ft)	113	249
extreme duty, 1,400 CCA	14	30	Oil, hydraulic, biodegradable synthetic	0	0	Counterweight	401	855
Converter, communication (CB)	5	11	Precleaner, snow	2	4.4	Cutting edges, curved	43	95
Lights:			Starter, heavy duty, 1,000 Amp	10	22	Endbits, overlay	24	52
Headlights, high	5	11	Transmission, autoshift	2	5	Front lift group, mounting	5	11
Headlights, low	5	11	OTHER ATTACHMENTS			Front lift group, mechanical	680	1,500
Working lights, basic	9	20	AccuGrade ARO	39	85	Grader bit, narrow and super penetration	181	400
Working lights, plus	10	22	Accumulators, blade lift	77	170	Mid-Mount Scarifier, Package	942	2,077
Warning: beacon or strobe	2	5	Camera, rearview	9	20	Mid-Mount Scarifier, Mounting	57	125
Mounting for warning light	5	11	Cat Product Link 321SR	13	29	Moldboard		
GUARDS			Cat Product Link 522	13	29	4267 mm × 610 mm × 22 mm (14 ft × 24 in × 7/8 in)	100	220
Articulation guard	13	30	Drain, ecology, engine Wiggins	2	5	4267 mm × 686 mm × 25 mm (14 ft × 27 in × 1 in)	257	567
Fenders, front	56	123	Heater, engine coolant:			Push plate	1285	2,833
Fenders, front, AWD	56	124	120V	1	3	Ripper, mounting	32	70
Fenders, rear	156	344	240V	1	3	Ripper, rear	962	2,120
Front axle guard	13	30	Hydraulic arrangements with one or more additional hydraulic valves are available for rear ripper, dozer, snow plow and snow wing.			Ripper tooth	28	61
Sound suppression (bottom)	110	243	Integrated cross slope	75	165	Scarifier, front	434	956
Sound suppression (enclosure)	15	33	Snow wing mounting, frame ready	91	200	Snow Arrangement	161	355
Transmission	141	311	Sound suppression	15	32	Snow Wing Ready Package	114	251
OPERATOR ENVIRONMENT			Starting aid, ether	0.5	1	Tow hitch	53	116
Fan, defroster, rear window	2	4	MACHINE ARRANGEMENTS			Canadian Arrangement	2	4
Mirrors, outside:			European Arrangement			European Arrangement	289	637
heated 24V	15	33	European Roding Arrangement			European Roding Arrangement	451	994
mounted	15	33						
Precleaner, HVAC	5	10						
Radio ready, AM/FM	9	20						
Seat, air suspension, cloth	2	5						
Shade, sun	2	5						
Wiper/washer, rear	2	4						

12M2/12M2 AWD Motor Graders

For more complete information on Cat products, dealer services, and industry solutions, visit us on the web at www.cat.com

© 2012 Caterpillar Inc.
All rights reserved

Materials and specifications are subject to change without notice. Featured machines in photos may include additional equipment. See your Cat dealer for available options.

CAT, CATERPILLAR, SAFETY.CAT.COM, their respective logos, "Caterpillar Yellow" and the "Power Edge" trade dress, as well as corporate and product identity used herein, are trademarks of Caterpillar and may not be used without permission.

AEHQ6324-02 (07-2012)
Replaces AEHQ6324-01

