

785C

Mining Truck



Engine

Engine Model	Cat® 3512B-EUI	
Gross Power – SAE J1995	1082 kW	1,450 hp
Net Power	1005 kW	1,348 hp

Weights – Approximate

Gross Machine Operating Weight	249 480 kg	550,000 lb
--------------------------------	------------	------------

Operating Specifications

Nominal Payload Capacity	136 tonnes	150 tons
--------------------------	------------	----------



Contents

Power Train – Engine3
 Power Train – Transmission4
 Engine/Power Train Integration.....5
 Structures.....6
 Operator’s Station7
 Cat Brake System.....8
 Truck Body Systems9
 Monitoring System.....10
 Safety11
 Sustainability12
 Serviceability13
 Customer Support.....14
 Specifications.....15
 Standard Equipment.....23
 Optional Equipment.....24
 Notes.....25

The 785C Mining Truck is engineered for performance, designed for comfort, and built to last. Developed specifically for high production mining and construction applications, the 785C Mining Truck keeps material moving at high volume to lower your cost-per-ton.

Rugged construction creates a durable machine. Easy maintenance procedures ensure high reliability and long life with low operating costs.

Power Train – Engine

The Cat® 3512B EUI twin turbocharged and aftercooled diesel engine delivers high power and reliability in the world's most demanding mining applications.

Engine

The Cat® 3512B EUI twin turbocharged and aftercooled diesel engine delivers high power and reliability in the world's most demanding mining applications.

Design

The 3512B is a 12-cylinder, four-stroke design that uses long, effective power strokes for more complete fuel combustion and optimum fuel efficiency.

EPA Compliant

Where applicable, the 3512B engine is compliant with U.S. Environmental Protection Agency emission requirements.

Altitude Compensation

Designed for maximum operating efficiencies at altitudes under 3048 m (10,000 ft).

High Torque Rise

The 23 percent net torque rise provides unequalled lugging force during acceleration, on steep grades and in rough underfoot conditions. Torque rise effectively matches transmission shift points for maximum efficiency and fast cycle times.

Enhanced Life

High displacement, low rpm rating and conservative horsepower ratings mean more time on the haul roads and less time in the shop.

Separate Circuit Aftercooler

Allows the aftercooler circuit to operate cooler than jacket water temperature for a denser air charge and greater combustion.

Engine Protection

Computerized system electronically protects the engine during cold starts, air filter plugging, high exhaust temperature and engine overspeed (ARC).

Electronic Control Module (ECM)

Utilizes advanced engine management software to monitor, control and protect the engine utilizing self-diagnosing electronic sensors. The computerized system senses operating conditions and power requirements and adjusts engine for peak performance and most efficient operation and at all times.

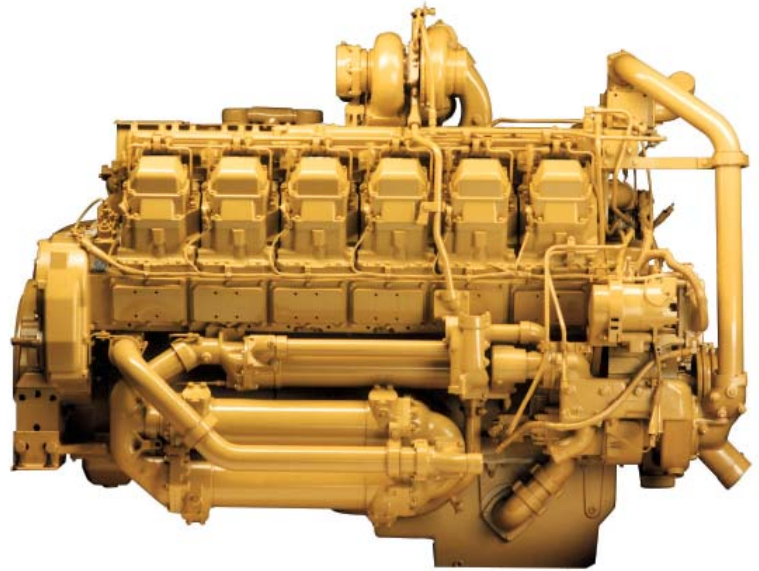

Power Train – Transmission

Cat mechanical power train delivers more power to the ground for greater productivity and lower operating costs.



Mechanical Power Train

The Cat mechanical drive power train and power shift transmission provides unmatched operating efficiency and control on steep grades, in poor underfoot conditions, and on haul roads with high rolling resistance.

1) Transmission

The Cat six-speed planetary power shift transmission is matched with the direct-injection 3512B diesel engine to deliver constant power over a wide range of operating speeds.

Robust Design

Designed for the higher horsepower of the 3512B engine, the proven planetary power shift transmission is built tough for long life between overhauls.

Transmission Chassis Control (TCC)

TCC uses electronically transferred engine rpm data to execute shifts at preset points for optimum performance, efficiency and clutch life.

2) Lock-Up Torque Converter

Combines maximum rimpull and cushioned shifting of torque converter drive with the efficiency and performance of direct drive. Engages at approximately 8 km/h (5 mph), delivering more power to the wheels.

3) Final Drives

Cat final drives work as a system with the planetary power shift transmission to deliver maximum power to the ground. Built to withstand the forces of high torque and impact loads, double reduction final drives provide high torque multiplication to further reduce drive train stress.

Wheels and Rims

Cast rear wheels and Cat center-mount rims are mounted using studs and nuts to minimize maintenance and maximize durability.

Steering System

Hydraulic steering control system is designed for exceptional smoothness and precise control. A separate circuit prevents cross contamination for long life.

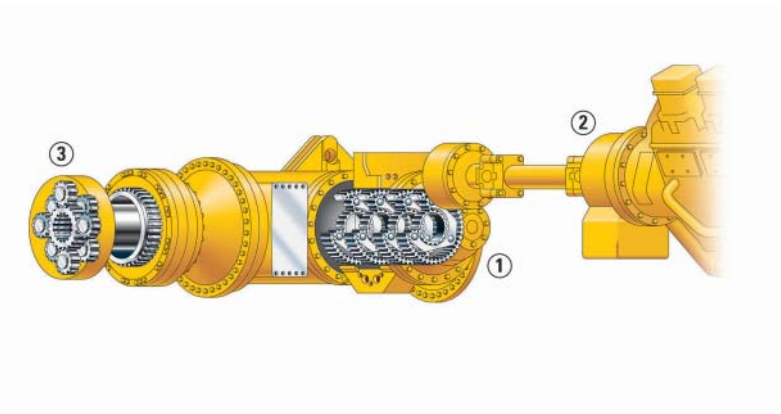

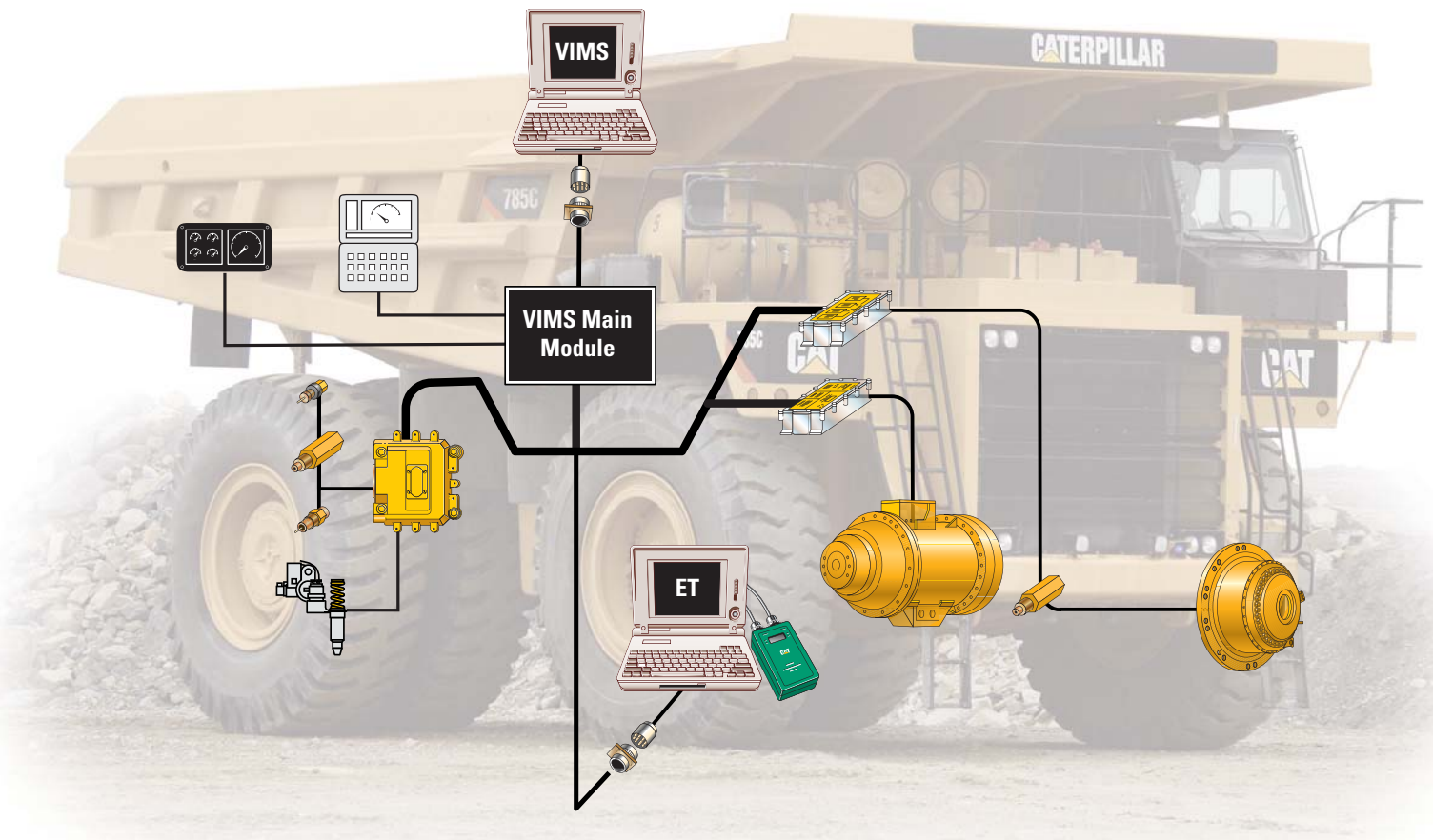

Engine/Power Train Integration

Electronically combines critical power train components to work more intelligently and to optimize overall truck performance.

Cat Data Link

Electronically integrates machine computer systems to optimize overall power train performance, increase reliability and component life, and reduce operating costs.

Electronic Technician (Cat ET)

Cat ET service tool provides service technicians with easy access to stored diagnostic data through the Cat Data Link to simplify problem diagnosis and increase machine availability.

Integrated Braking Control (IBC)

IBC integrates Automatic Retarder Control and Traction Control into one system for optimum performance and efficiency.

Body-up Reverse Neutralizer

Automatically shifts the transmission to neutral if the hoist lever is activated while transmission is shifted in reverse.

Supplemental Steering

Supplemental Steering system uses pressure accumulators and allows up to three 90-degree turns in case of engine failure.

Structures

Rugged Cat structures are the backbone of the 785C mining truck's durability.

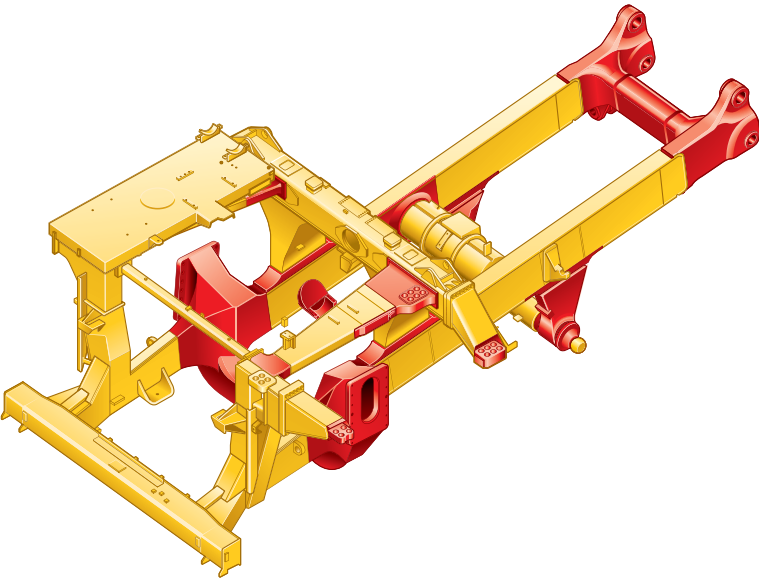

Box-Section Design

The 785C frame uses a box-section design, incorporating two forgings and 21 castings in high stress areas with deep penetrating and continuous wrap-around welds to resist damage from twisting loads without adding extra weight.

Serviceability

The open box-section frame design allows easy access to power train components, reducing overall removal and installation time, and lowering overall repair costs. The raised and pinned body allows excellent access to the transmission.

Steel Structures

Mild steel used throughout frame provides flexibility, durability and resistance to impact loads, even in cold climates, and allows for easy field repairs.

Integral Four-Post ROPS Cab

Resiliently mounted to the main frame to reduce vibration and sound, the integral ROPS is designed as an extension of the truck frame. The ROPS/FOPS structure provides “five-sided protection” for the operator.

Suspension System

Designed to dissipate haul road and loading impacts for longer frame life and a more comfortable ride.

Cylinders

Four independent self-contained, oil pneumatic, variable-rebound suspension cylinders are designed to absorb shocks in the most severe applications.

Durable Design

Rugged cylinders utilize large diameter bore and low-pressure nitrogen/oil design for long life with minimal maintenance.

- **Front.** Front cylinders with preset caster and camber are mounted to the frame and serve as steering kingpins for a tight turning radius with excellent maneuverability and low maintenance.
- **Rear.** Rear cylinders allow axle oscillation and absorb bending and twisting stresses caused by uneven and rough haul roads rather than transmitting them to the main frame.

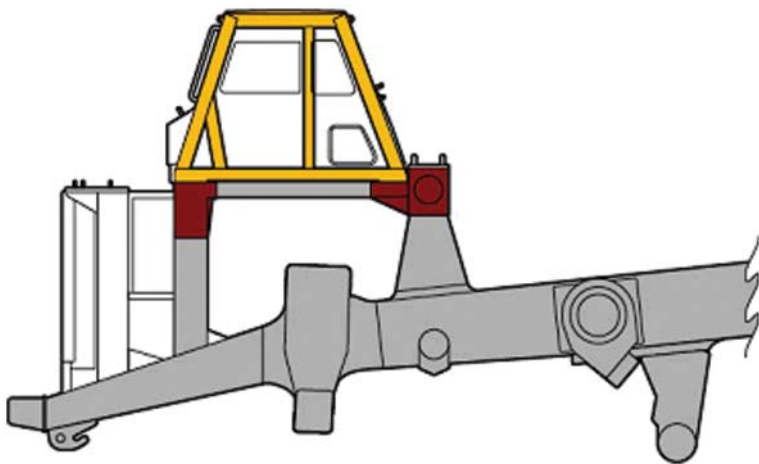



Operator's Station

Ergonomically designed for operator comfort, superior control and high productivity.

Enhanced Operator Visibility

Through the use of the fully Integrated Object Detection System, RADAR AND CAMERA, the operator can receive both audible and visual indications of detected objects.

Ergonomic Layout

The 785C operator station is ergonomically designed for total machine control in a comfortable, productive and safe environment. All controls, levers switches and gauges are positioned to maximize productivity and minimize operator fatigue.

Quiet Cab

Integral, sound-suppressed ROPS/FOPS cab is resiliently mounted to the mainframe to isolate the operator from sound and vibration for a quiet, secure and comfortable ride.

Viewing Area

Designed for excellent all-around visibility and clear sight lines to the haul road, the large viewing area enables the operator to maneuver with confidence for high productivity.

- 1) Air Suspension Seat with Three-Point Operator Restraint
- 2) Hoist Lever
- 3) Secondary Brake Pedal
- 4) Monitoring System
- 5) Steering Column
- 6) Transmission Console
- 7) Parking Brake Reset Valve
- 8) Storage Compartment
- 9) Trainer Seat
- 10) Operator Window
- 11) Operator Controls
- 12) Heating/Air Conditioning

Radio Ready

The operator's station comes ready with power ports, speakers, antenna, and electrical connections to facilitate trouble-free radio installation. Consult your dealer for the complete line of available Cat radio options including satellite radio.

Cat[®] Brake System

Reliable braking with superior control gives the operator the confidence to focus on productivity.



Integrated Braking System

The Cat oil-cooled braking system delivers reliable performance and control in the most extreme haul road conditions. The integrated system combines the service, secondary, parking brake and retarding functions in the same robust system for optimum braking efficiency.

Oil-Cooled Multiple Disc Brakes

Cat four-wheel, forced oil-cooled, multiple disc service brakes are continuously cooled by water-to-oil heat exchangers for exceptional, non-fade braking and retarding performance.

Extended Life Disc Brakes

Cat oil-cooled disc brakes are designed with large discs and plates for reliable, adjustment-free operation and performance. Brakes are completely enclosed and sealed to prevent contamination and reduce maintenance. Additionally, this machine features optional extended life friction material that has double the wear life of standard brakes and is twice as resistant to glazing resulting in more consistent braking power with less noise.

Pistons

The Caterpillar two-piston design combines the service, secondary, parking brake and retarding functions in the same system. The primary piston hydraulically actuates both service and retarding functions. The secondary piston is spring-applied and held in the disengaged position by hydraulic pressure. If hydraulic system pressure drops below a specified level, the spring-applied secondary piston automatically applies the brakes.

Parking Brake

Oil-cooled, spring-applied, hydraulically released parking brake is applied to all four wheels for superior parking capability on all grades up to 15 percent.

Hydraulic Automatic Retarder Control (HARC)

Hydraulically activated automatic retarder control system electronically controls retarding on grade to maintain optimum engine rpm and oil cooling. Additional braking may be applied using the manual retarder or the brake pedal. HARC is deactivated when the operator applies the brakes or accelerator controls.

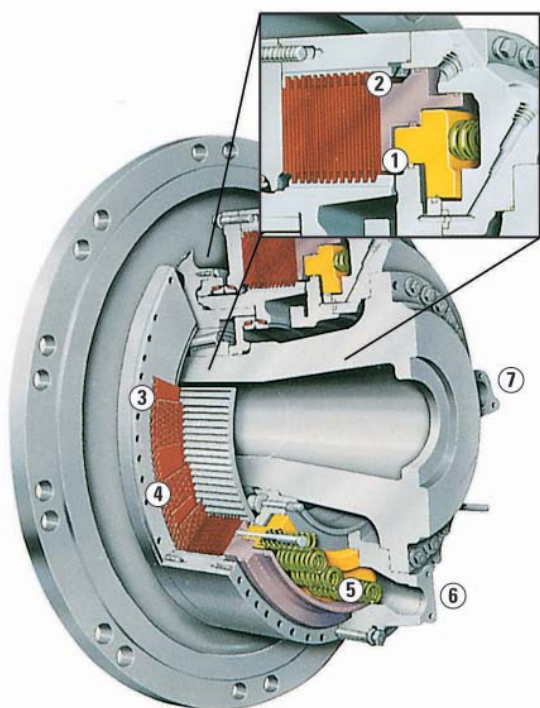

1) Parking/Secondary Piston 2) Service/Retarding Piston 3) Friction Discs
4) Steel Plates 5) Actuating Springs 6) Cooling Oil In 7) Cooling Oil Out

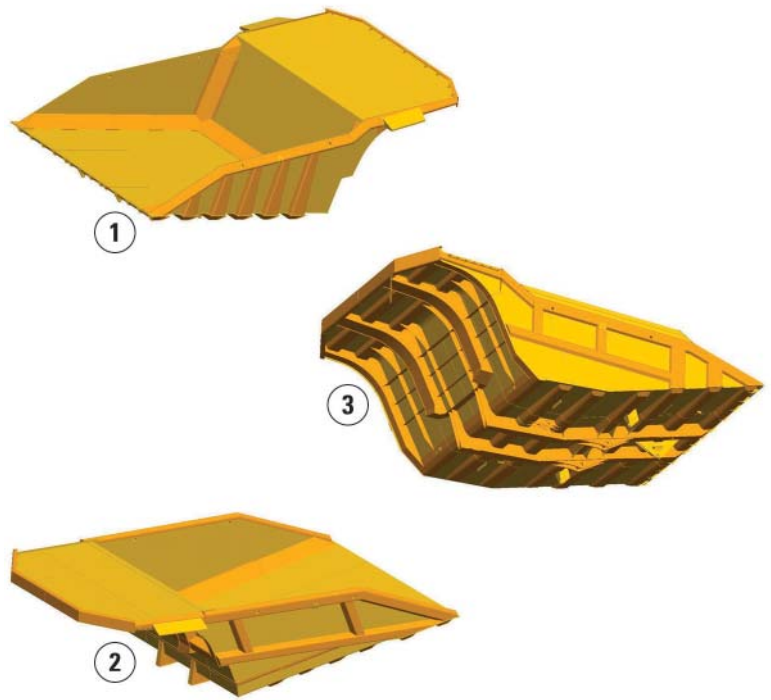

Truck Body Systems

Caterpillar designed and built for rugged performance and reliability in the toughest mining applications.

Cat Truck Bodies

Matching the truck body to the application is a critical part of achieving the best value from your 785C. Caterpillar offers a variety of application specific body options that yield a payload ranging from 131 to 144 metric tons (144 to 158 tons). The Caterpillar exclusive 10/10/20 payload guidelines help achieve a balance of excellent payload with safe operation.

Body Options

- 1) **Cat "X" Body** – The X body is a heavy duty body configured with a variety of liner options to meet site specific requirements of a mine. Like the Dual Slope – the X body is designed for durability across a range of harsh applications.
- 2) **Mine Specific Body (MSD II)** – For mature mines with good operational and maintenance practices, the lighter weight MSD II (Mine Specific Design) body is available in several sizes. It is a customer/site specific body that is designed to maximize performance. The MSD II is designed to maximize payload, provide good durability and can be configured with a variety of liner options to meet the specific requirements of the mine.
- 3) **Gateless Coal Body** – This specialized high volume body, available in several sizes, is targeted at dedicated coal haulage applications with minimal impact. The kicked up floor design eliminates the tailgate and gives the volume required to meet target payload.
- 4) **Dual Slope Body** – The original standard body, the Dual Slope body, provides excellent load retention, maintains a low center of gravity with optimum load distribution, reduces shock loading and is available in lined and unlined configurations. The Dual Slope body is intended for tough applications including greenfield sites and contracting mines.

Custom Body Options

A variety of options including tail extensions, sideboards, tumble bars, rock boxes and rock shedders are available to maintain rated payload, reduce spillage and improve hauling efficiencies.

1) X Body 2) MSD II Body 3) Gateless Coal Body 4) Dual Slope Body (not shown)

Monitoring System

Vital machine health and payload data keeps the 785C performing at peak production levels.

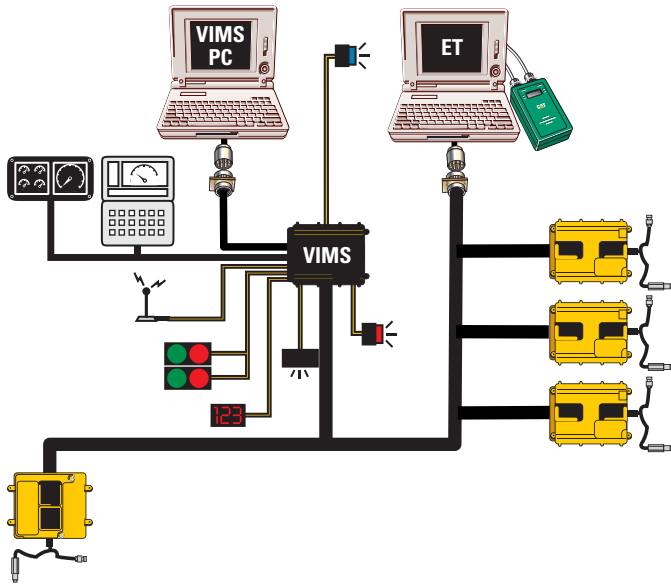

VIMS® Monitoring System

Intelligent Caterpillar designed machine monitoring system provides critical machine health and payload data in real-time to keep the 785C performing at top production levels.

Production Management

Production Management enhances truck/loading tool effectiveness, improves fleet productivity and helps extend the life of truck frames, tires, rims and power train components, while lowering operating and maintenance cost.

Payload Management

Max Payload Speed Manager is a feature that aids in managing the Caterpillar 10/10/20 Overload Policy. Based on target payload weight and overload settings, the VIMS system logs and warns the operator when the truck reaches overload after second gear reweigh. The truck will be limited to second gear at 1,750 rpm, and the automatic retarder speed setting is reduced to 1,750 rpm until the load is dumped.

Road Analysis Control (RAC)

Optional system monitors haul road conditions by measuring frame rack and pitch to improve haul road maintenance, cycle times, tire life and fuel efficiency.

VIMS-PC

VIMS-PC, the off-board reporting software program, allows service personnel to download a complete record of machine health and productivity data to a laptop computer for diagnosis and analysis. Easy-to-use software enables service technicians and mine management to generate health and payload reports for more effective machine management.

VIMS Supervisor

Optional software allows mine management to easily manage and interpret VIMS data for optimum fleet management and productivity.

Machine Management

Service technicians or mine personnel can download data and generate reports. Data can be used to improve effectiveness of scheduled maintenance programs, maximize component life, improve machine availability, and lower operating costs.

Gauge Cluster

Conveniently located gauge cluster maintains a constant display of vital machine functions.



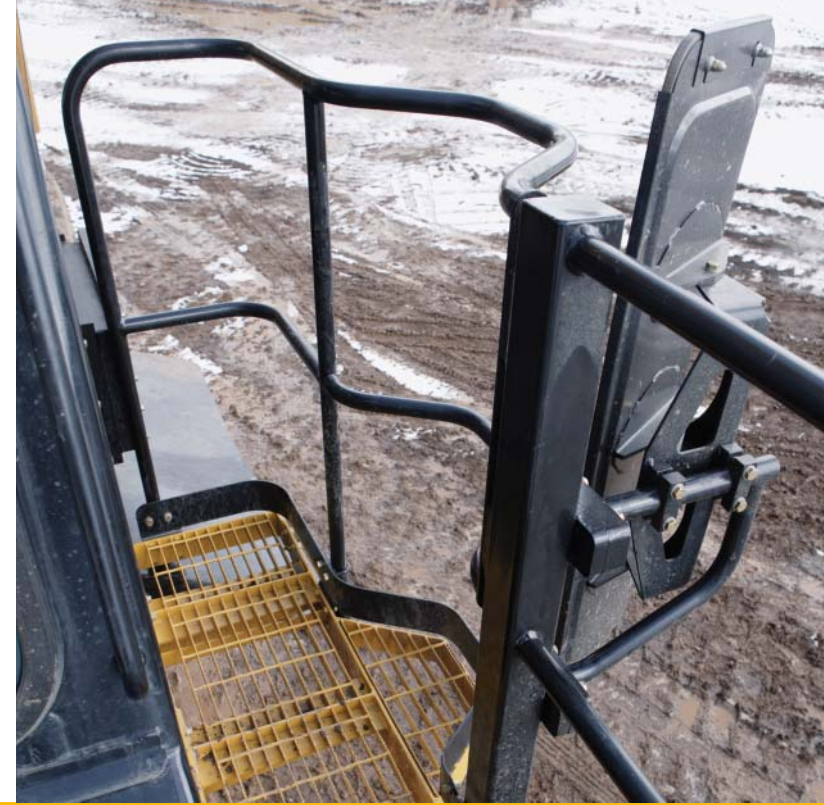

Safety

Cat mining machines and system are designed with safety as their first priority.

Product Safety

Caterpillar has been and continues to be proactive in developing mining machines that meet or exceed safety standards. Safety is an integral part of all machine and system designs.

Integrated Object Detection Systems

Object Detection Systems are factory installed as standard equipment on 785C mining trucks. The fully Integrated Object Detection System, RADAR AND CAMERA, provides both audible and visual indications of detected objects. This system uses a combination of short and medium range radars which surround the machine, along with cameras on each side to allow the operator to confirm the detected object. The cameras supplement the radar alerts and are selectable by touch screen menus through an intuitive interface.

Machine Safety Features

Caterpillar incorporates safety into every aspect of our machines. Every machine meets or exceeds SAE and ISO standards and has the ROPS integrated into the cab design. An engine shutoff switch and an electrical system cutoff are conveniently located at ground level.

Overload Policy

Adherence to the Caterpillar 10/10/20 Overload Policy assures that steering and braking systems have sufficient capacity to perform.

Standard Safety Features

Slip resistant surfaces, retractable, seat/shoulder belts with three-point operator restraint, wide-angle mirrors, body raised indicator, body retaining cable, guard rails, reverse neutralizer when dumping, low interior sound level, secondary steering system.

SAFETY.CAT.COM[™]



Sustainability

A variety of features improve sustainability in areas of decreasing waste, extending component life and lowering emissions levels.

Sustainability Features

The 785C Mining Truck offers oil renewal systems, extended life filters and extended maintenance intervals which aid in decreasing the amount of waste contributed to our environment.

Oil Renewal System

Optional oil renewal system extends engine oil change intervals from 500 hours to 4,000 hours or more to increase machine availability and reduce costs.

Engines with Advanced Technology

Engines with advanced technology contribute less emissions to the environment while maintaining fuel efficiency.

Advanced Surface Technology (AST)

Advanced Surface Technology (AST) is a replacement for hard chrome coatings on some steel parts, including suspension and hoist cylinder rods. This technology improves wear resistance and reduces repair time. Chrome has been eliminated to reduce environmental impact.

Fuel Efficiency

The engine provides additional retarding by running against compression on downhill hauls. During retarding applications the engine ECM does not inject fuel into the cylinders for exceptional fuel economy.

Serviceability

Less time spent on maintenance means more time on the haul roads.

Servicing Ease

Easy access to daily service points simplifies servicing and reduces time spent on regular maintenance procedures. Enhanced serviceability and 500-hour service intervals are designed to increase machine availability and productivity.

Maintenance Platform

Provides access to engine, air filters, steering hydraulic tank and battery compartment.

In-Frame Access

Permits easy access to major components for easy servicing and removal.

Ground-Level Access

Allows convenient servicing to tanks, filters, drains, and engine shutdown. Ground-level VIMS data port permits easier downloading of information.

Autolube

Automatic lubrication system reduces maintenance time by automatically lubricating necessary components on a regular basis.

Fast Fill Service Center

Optional fast fill service center features high-speed fuel and oil exchange.

Scheduled Oil Sampling

S-O-SSM sampling valves speed sampling and analysis reliability.

Pressure Test Points

Disconnect valves are conveniently located throughout the hydraulic systems for easy pressure testing.

Sealed Electrical Connectors

Electrical connectors are sealed to lock out dust and moisture. Harnesses are braided for protection. Wires are color coded for easy diagnosis and repair.

Cylinder Heads

Individual cylinder heads are interchangeable for easy removal and visual inspection of internal parts.

On-Board Diagnostic Systems

The VIMS monitoring system continuously monitors all critical machine functions and components to help locate faults quickly for faster repair. Electronic Control Systems provide diagnosis of engine, transmission, brake and chassis systems. Service Technicians utilize the Electronic Technician service tool (Cat ET) to program and troubleshoot these systems.





Customer Support

Cat dealers have what it takes to keep mining trucks productive.

Commitment Makes the Difference

Cat dealers offer a wide range of solutions, services and products that help you lower costs, enhance productivity and manage your operation more efficiently. Support goes far beyond parts and service. From the time you select a piece of Cat equipment until the day you rebuild, trade or sell it, the support you get from your Cat dealer makes the difference that counts.

Dealer Capability

Cat dealers will provide the level of support you need, on a global scale. Dealer expert technicians have the knowledge, experience, training and tooling necessary to handle your repair and maintenance needs, when and where you need them.

Product Support and Service Support

Supported by a worldwide network of parts distribution facilities, dealer service centers and technical training facilities, Cat dealers can maximize your uptime. With a tailored service plan, your dealer can help you get the most return on your investment.

Training

Your Cat dealer can arrange training programs to help operators improve productivity, decrease downtime, reduce operating costs, enhance safety, and improve return on the investment you make in Cat products.

Technology Products

Cat dealers offer a range of advanced technology products such as VIMS monitoring system and MineStar™ information management system. These products include radio data communications, machine monitoring and diagnostics, fleet management, and haul road maintenance software – all designed to improve fleet efficiency, increase productivity, and lower costs.

www.cat.com

For more complete information on Cat products, dealer services, and industry solutions, visit us on the web at www.cat.com.

785C Mining Truck Specifications

Engine

Engine Model	Cat® 3512B-EUI	
Rated Power	1,750 rpm	
Gross Power – SAE J1995	1082 kW	1,450 hp
Net Power – SAE J1349	1005 kW	1,348 hp
Net Power	1005 kW	1,348 hp
Net Power – Cat	1005 kW	1,348 hp
Net Power – ISO 9249	1005 kW	1,348 hp
Net Power – 80/1269/EEC	1005 kW	1,348 hp
Torque Rise	23%	
Bore	170 mm	6.7 in
Stroke	190 mm	7.5 in
Displacement	51.8 L	3,158 in ³

- Net power advertised is the power available at rated speed of 1,750 rpm, measured at the flywheel when the engine is equipped with fan, air cleaner, muffler and alternator.
- Ratings based on standard air conditions of 25° C (77° F) and 99 kPa (29.32 Hg) dry barometer. Power based on fuel having API gravity of 35 at 16° C (60° F) and an LHV of 42 780 kJ/kg (18,390 BTU/lb) when engine used at 30° C (86° F).
- No engine derating required up to 3050 m (10,000 ft) altitude.
- Where applicable, the 3512B engine is compliant with U.S. Environmental Protection Agency emission requirements.

Weights – Approximate

Gross Machine Operating Weight	249 480 kg	550,000 lb
Chassis Weight	74 450 kg	164,134 lb
Operating Weight – Empty – Flat Floor Body	102 150 kg	225,200 lb
Operating Weight – Empty – Dual Slope	95 725 kg	211,035 lb

Operating Specifications

Nominal Payload Capacity	136 tonnes	150 tons
SAE (2:1) Capacity	78 m ³	102 yd ³
Top Speed – Loaded	55 km/h	34 mph
Maximum Capacity	Custom	
Maximum Capacity Struck (SAE)	Custom	
Steer Angle	36°	
Turning Diameter – Front	27.5 m	90 ft 2 in
Raise Time	15.2 Seconds	
Lower Time	15.9 Seconds	
Machine Clearance Turning Diameter	30.6 m	100 ft 5 in

- Refer to the Cat Mining Truck 10-10-20 payload policy for maximum gross machine weight limitations.

Transmission

Forward 1	12.1 km/h	7.5 mph
Forward 2	16.3 km/h	10.2 mph
Forward 3	22.2 km/h	13.8 mph
Forward 4	29.9 km/h	18.6 mph
Forward 5	40.6 km/h	25.2 mph
Forward 6	54.8 km/h	34 mph
Reverse	11 km/h	6.8 mph

- Maximum travel speeds with standard 33.00-R51 tires.

Final Drives

Differential Ratio	2.10:1	
Planetary Ratio	10.83:1	
Total Reduction Ratio	22.75:1	

- Planetary, full-floating.

Suspension

Effective Cylinder Stroke – Front	306.5 mm	12.1 in
Effective Cylinder Stroke – Rear	165 mm	6.5 in

Brakes

Brake Surface – Front	61 270 cm ²	9,497 in ²
Brake Surface – Rear	89 729 cm ²	13,908 in ²
Standards	SAE J1473 OCT90 ISO 3450-1985	

- Maximum operating weight up to 249 480 kg (550,000 lb).

Body Hoists

Pump Flow – High Idle	750 L/min	198 gal/min
Relief Valve Setting – Raise	17 238 kPa	2,500 psi
Body Raise Time – High Idle	15.2 Seconds	
Body Lower Time – High Idle	15.9 Seconds	
Body Lower Time – Float	16.2 Seconds	
Body Power Down – High Idle	15.9 Seconds	

- Twin, two-stage hydraulic cylinders mounted inside main frame; double-acting cylinders in second stage.
- Power raise in both stages; power down in second stage.

785C Mining Truck Specifications

Approximate Weights – Dual Slope

Gross Weight – Empty	95 725 kg	211,035 lb
Chassis	74 450 kg	164,134 lb
Body	21 258 kg	46,865 lb
Front Axle – Empty	47%	
Rear Axle – Empty	53%	
Front Axle – Loaded	33%	
Rear Axle – Loaded	67%	

Approximate Weights – Flat Floor

Gross Weight – Empty	102 130 kg	225,200 lb
Chassis	74 450 kg	164,134 lb
Body	25 687 kg	56,630 lb
Standard Liner	1996 kg	4,400 lb
Front Axle – Empty	47%	
Rear Axle – Empty	53%	
Front Axle – Loaded	33%	
Rear Axle – Loaded	67%	

- Percentages represent weight distribution without liner.

Weight Distributions – Approximate

Front Axle – Empty	47%
Rear Axle – Empty	53%
Front Axle – Loaded	33%
Rear Axle – Loaded	67%

Capacity – Dual Slope – 100% fill factor

Struck	57 m ³	74 yd ³
Heaped (SAE 2:1)	78 m ³	102 yd ³

Capacity – Flat Floor – 100% fill factor

Struck	74 m ³	96 yd ³
Heaped (SAE 2:1)	91 m ³	119 yd ³

Service Refill Capacities

Fuel Tank	1893 L	500 gal
Cooling System	379 L	100 gal
Crankcase	204 L	54 gal
Differentials and Final Drives	436 L	115 gal
Steering Tank	90 L	24 gal
Steering System (Includes Tank)	117 L	31 gal
Brake/Hoist Hydraulic Tank	337 L	89 gal
Brake/Hoist System (Includes Tank)	641 L	169 gal
Torque Converter/ Transmission System (Includes Sump)	248 L	65.51 gal

ROPS

ROPS Standards	SAE J1040 APR88 ISO 3471:1994
----------------	----------------------------------

- ROPS (Rollover Protective Structure) for cab offered by Caterpillar meets SAE J1040 APR88 and ISO 3471:1994 Level II ROPS criteria.

Sound

Sound Standards	ANSI/SAE J1166 MAY90 SAE J88 APR95
-----------------	--

- The operator sound exposure Leq (equivalent sound pressure level) measured according to work cycle procedures specified in ANSI/SAE J1166 MAY90 is 80 dB(A) for cab offered by Caterpillar, when properly installed and maintained and tested with doors and windows closed.
- The exterior sound pressure level for the standard machine measured at a distance of 15 m (49 ft) according to the test procedures specified in SAE J88 APR95, mid-gear moving operation is 89 dB(A).
- Hearing protection may be needed when operating with an open operator station and cab (when not properly maintained or doors/windows open) for extended periods or in a noisy environment.

Steering

Steering Standards	SAE J1511 OCT90 ISO 5010:1992
--------------------	----------------------------------

- Turning diameter on front wheel track with standard tires: 27.5 m (90 ft 2 in).
- Machine clearance turning diameter: 30.6 m (100 ft 5 in).
- Steering angle, left or right: 36 degrees.
- Separate hydraulic system prevents cross contamination.

Tires

Standard Tire	33.00-R51 (E4) 33.00-R51 (E3)
---------------	----------------------------------

- Productive capabilities of the 785C truck are such that, under certain job conditions, TKPH (TMPH) capabilities of standard or optional tires could be exceeded and, therefore, limit production.
- Caterpillar recommends the customer evaluate all job conditions and consult the tire manufacturer for proper tire selection.

Dimensions

All dimensions are approximate.

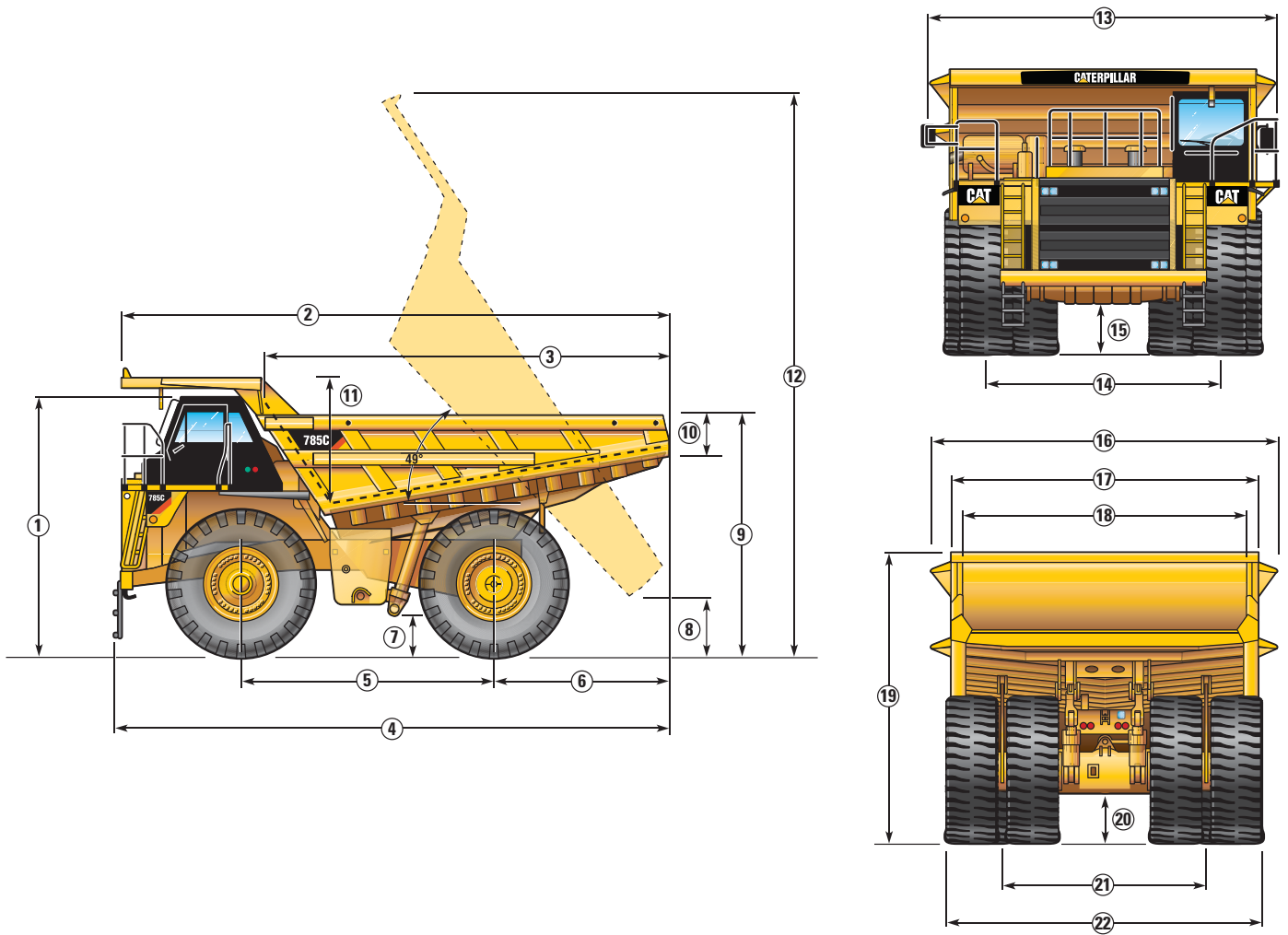

1	Height to Top of ROPS	5122 mm	16 ft 10 in
2	Overall Body Length	10 615 mm	34 ft 10 in
3	Inside Body Length	7652 mm	25 ft 2 in
4	Overall Length	11 024 mm	36 ft 3 in
5	Wheelbase	5182 mm	17 ft 0 in
6	Rear Axle to Tail	3410 mm	11 ft 3 in
7	Ground Clearance	987 mm	3 ft 3 in
8	Dump Clearance	1284 mm	4 ft 3 in
9	Loading Height – Empty	4968 mm	16 ft 4 in
10	Rear Sidewall Height	906 mm	3 ft 0 in
11	Inside Body Depth – Max.	2132 mm	7 ft 0 in

12	Overall Height – Body Raised	11 207 mm	36 ft 10 in
13	Operating Width	6640 mm	21 ft 10 in
14	Centerline Front Tire Width	4850 mm	15 ft 11 in
15	Engine Guard Clearance	1057 mm	3 ft 6 in
16	Overall Canopy Width	6200 mm	20 ft 5 in
17	Outside Body Width	5890 mm	19 ft 4 in
18	Inside Body Width	5510 mm	18 ft 1 in
19	Front Canopy Height	5769 mm	19 ft 0 in
20	Rear Axle Clearance	1080 mm	3 ft 7 in
21	Centerline Rear Dual Tire Width	4285 mm	14 ft 1 in
22	Overall Tire Width	6274 mm	20 ft 8 in

785C Mining Truck Specifications

Retarding Performance

To determine retarding performance: Add lengths of all downhill segments and, using this total, refer to proper retarding chart. Read from gross weight down to the percent effective grade. Effective grade equals actual % grade minus 1% for each 10 kg/t (20 lb/ton) of rolling resistance. From this weight-effective grade point, read horizontally to the curve with the highest obtainable gear, then down to maximum descent speed brakes can properly handle without exceeding cooling capacity. The following charts are based on these conditions: 32° C (90° F) ambient temperature, at sea level, with 33.00-R51 tires.

NOTE: Select the proper gear to maintain engine rpm at the highest possible level, without overspeeding the engine. If cooling oil overheats, reduce ground speed to allow transmission to shift to the next lower speed range.

- Typical Field Empty Weight
- - - - - Gross Machine Operating Weight
249 500 kg (550,000 lb)

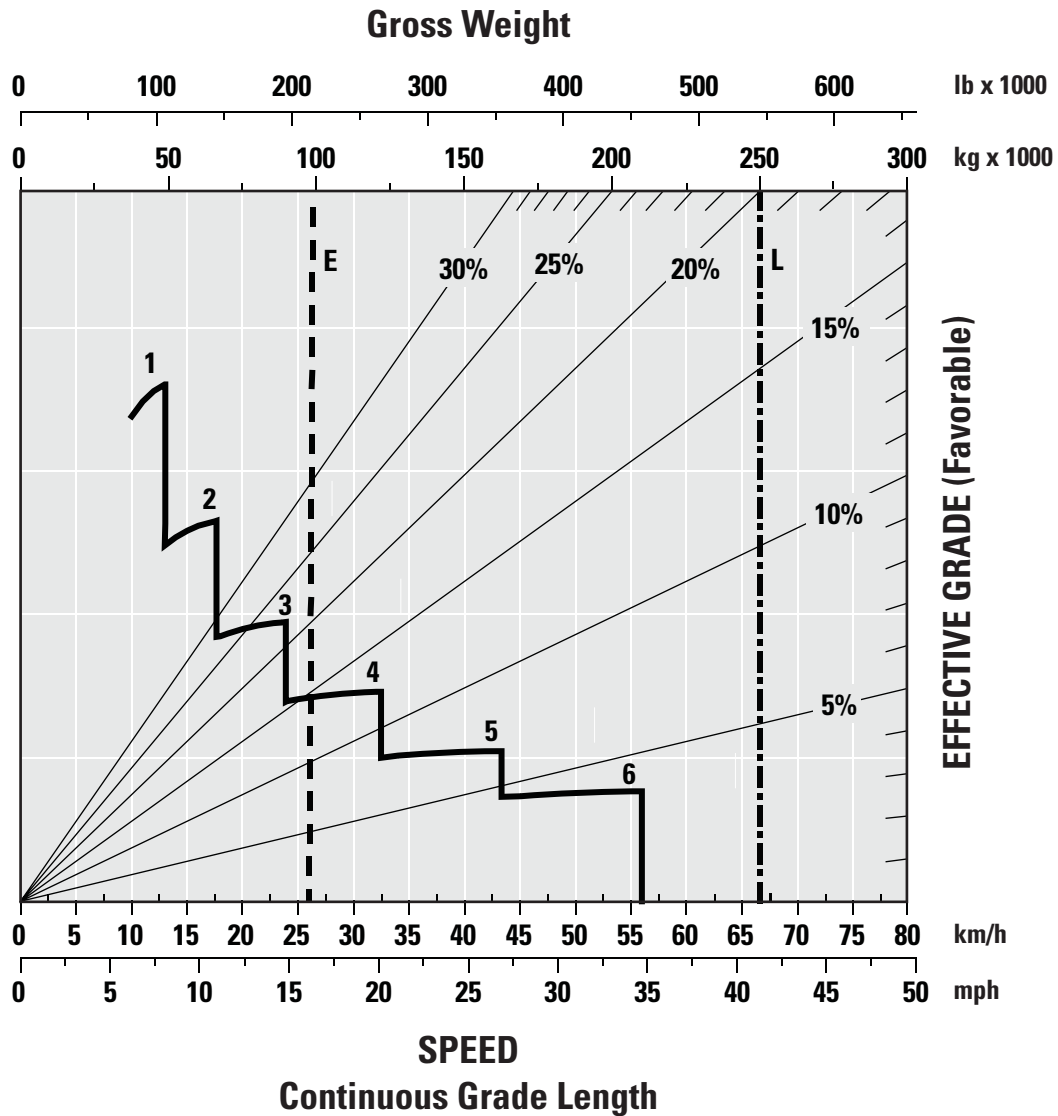

- E – Empty
- L – Loaded

Retarding Performance

- Typical Field Empty Weight
- Gross Machine Operating Weight
249 500 kg (550,000 lb)

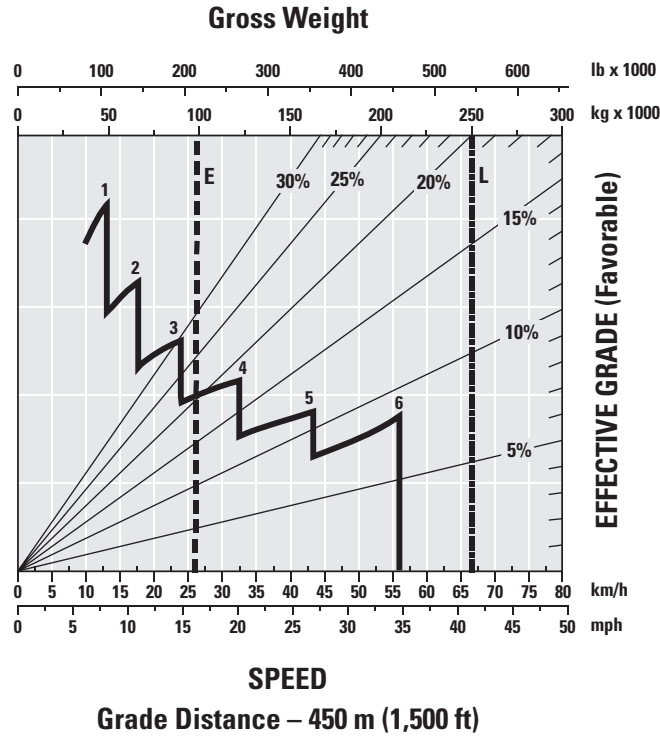

- E – Empty
- L – Loaded

- Typical Field Empty Weight
- Gross Machine Operating Weight
249 500 kg (550,000 lb)

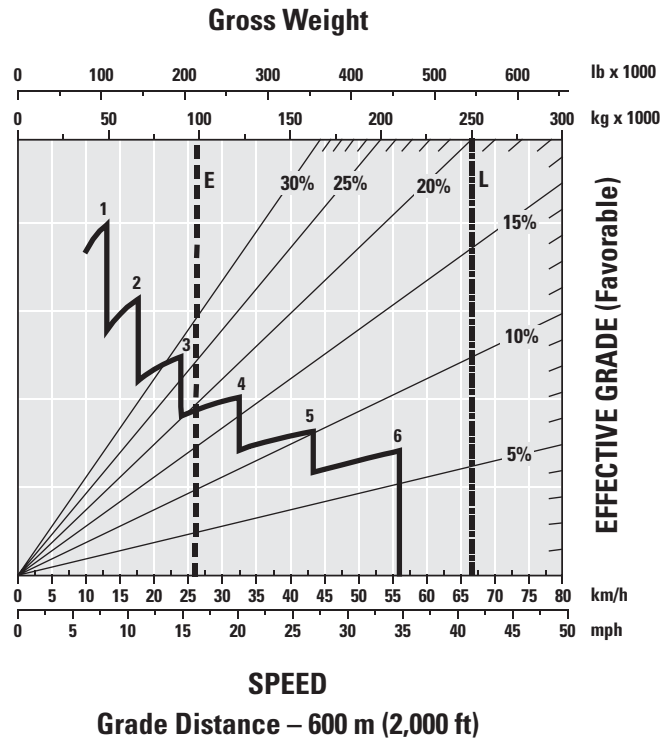

- E – Empty
- L – Loaded

785C Mining Truck Specifications

Retarding Performance

- — — — Typical Field Empty Weight
- · — · — · Gross Machine Operating Weight
249 500 kg (550,000 lb)

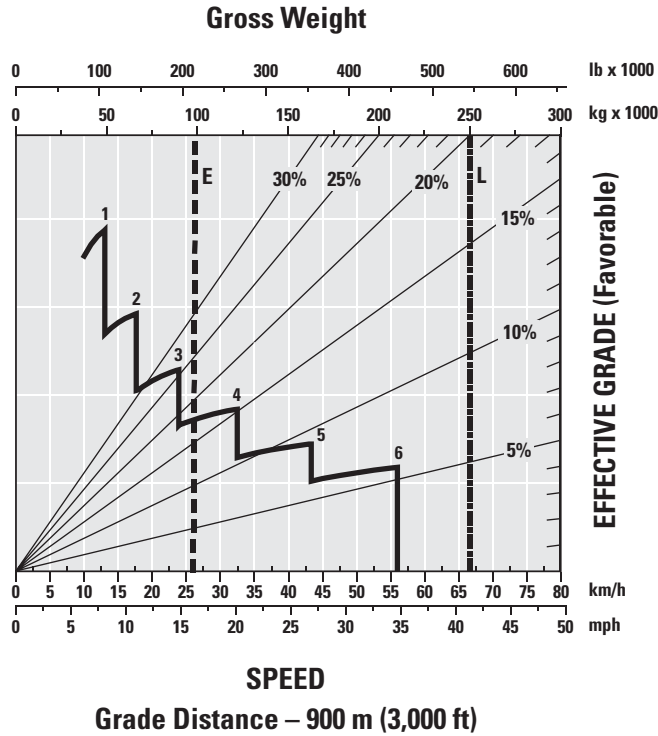

- E – Empty
- L – Loaded

- — — — Typical Field Empty Weight
- · — · — · Gross Machine Operating Weight
249 500 kg (550,000 lb)

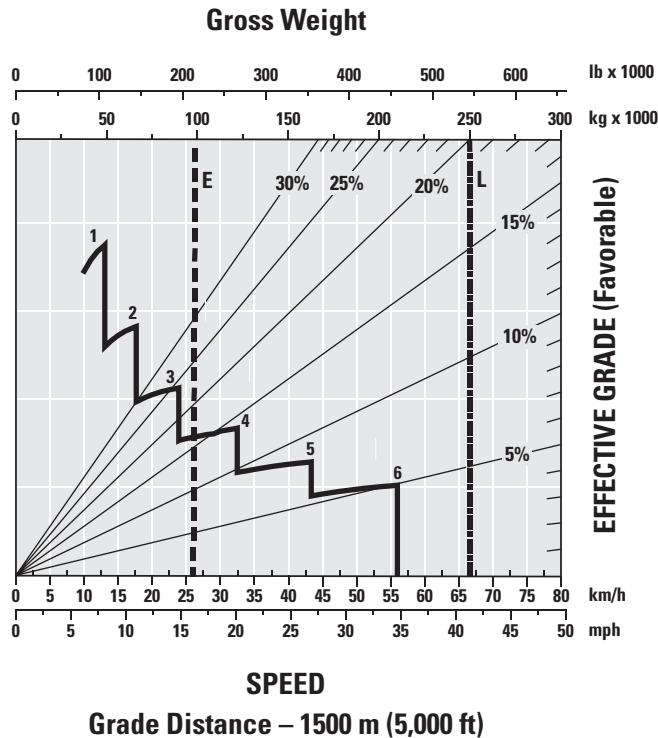

- E – Empty
- L – Loaded

Gradeability/Speed/Rimpull

To determine gradeability performance: Read from gross weight down to the percent of total resistance. Total resistance equals actual percent grade plus 1% for each 10 kg/t (20 lb/ton) of rolling resistance. From this weight-resistance point, read horizontally to the curve with the highest obtainable gear, then down to maximum speed. Usable rimpull will depend upon traction available and weight on drive wheels.

- Typical Field Empty Weight
- 136 080 kg (300,000 lb)

33.00-R51 Tires Gross Weight

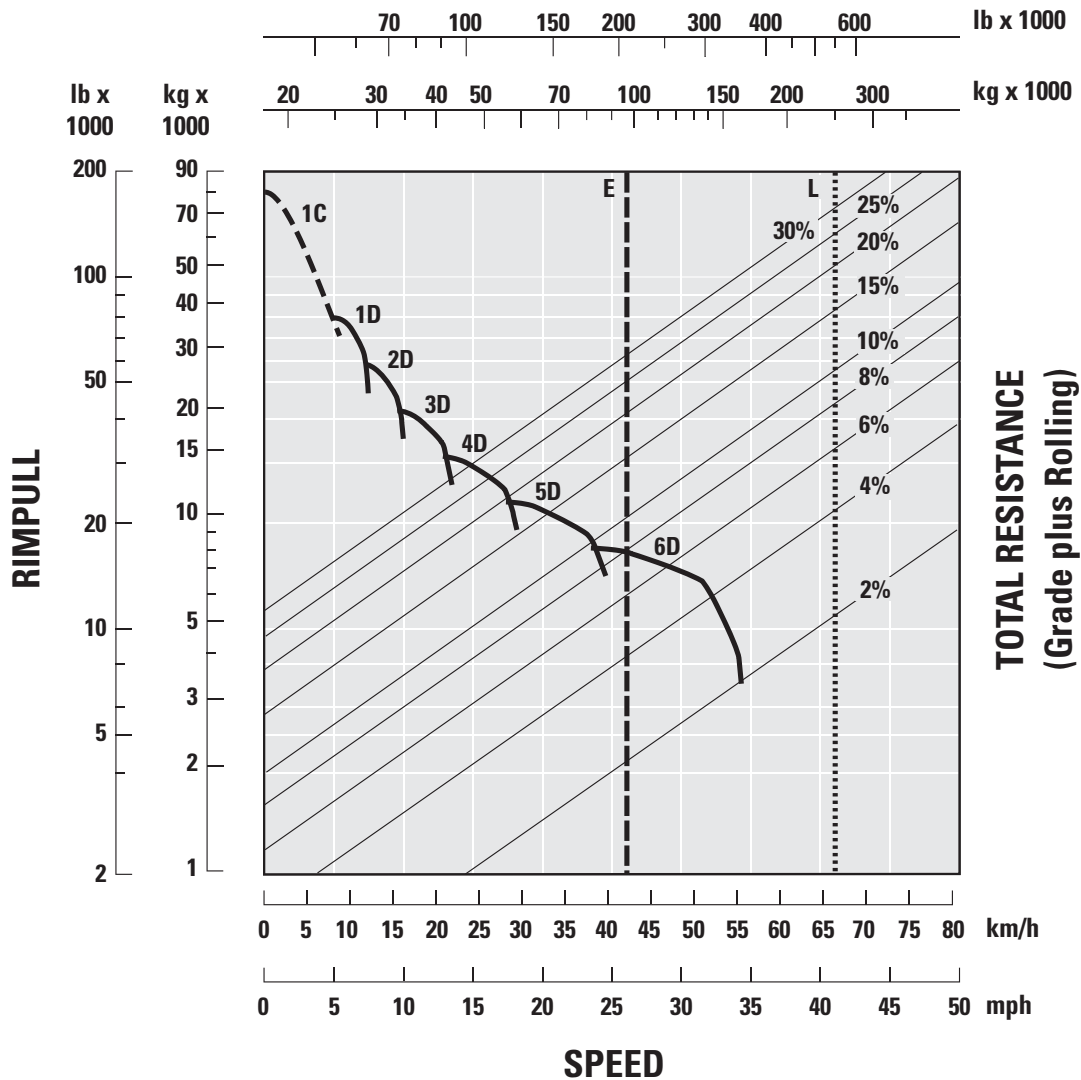

- Torque Converter Drive
- Direct Drive

- E – Empty
- L – Loaded

785C Mining Truck Specifications

Weight/Payload Calculation*

(Example)

	Flat Floor		Dual Slope	
	kg	lb	kg	lb
Empty Chassis Weight	55 421	122,180	55 421	122,180
Fuel Tank and Fuel 1892 L (500 gal)	2232	4,920	2232	4,920
Tires (33.00-R51)	10 492	23,130	10 492	23,130
Rim 610 mm (24 in)	6323	13,940	6323	13,940
Chassis Weight	<u>74 468</u>	<u>164,170</u>	<u>74 468</u>	<u>164,170</u>
Debris Allowance (4% of chassis)	2979	6,567	2979	6,567
Body Weight	25 687	56,630	21 258	46,865
Body Attachments Weight	1996	4,400	0	0
Additional Attachments Weight	<u>+</u>	<u>+</u>	<u>+</u>	<u>+</u>
Total Empty Operating Weight	<u>105 129</u>	<u>231,767</u>	<u>98 704</u>	<u>217,602</u>
Target Payload	<u>144 351</u>	<u>318,233</u>	<u>150 776</u>	<u>332,398</u>
Gross Machine Operating Weight	249 480	550,000	249 480	550,000

* **NOTE:** Refer to Caterpillar's 10/10/20 Payload Policy for calculating maximum gross machine weight allowable.

Standard equipment may vary. Consult your Cat dealer for details.

Air Cleaner with Precleaner (2)	Crankcase Protection	Rims, Center Mounted for 33.00-R51 Tires
Air Conditioner	Driveline Operator Safety Guard	Rock Ejectors
Air Line Dryer (2)	Dumping, Auxiliary Quick Connect for "Buddy Dumping"	Starting Aid, Ether, Automatic
Air Starter, Vane-type	Electrical System, 24-volt to 12-volt	Steering, Auxiliary Quick Connect for Towing
Alarm, Back-up	Engine – Cat 3512B with Electronic Injection and Multi Point Oil Pressure Sensing	Tie Down Eyes
Alternator (105-amp)	Fast-fill Fuel System, Wiggins	Tow Hooks, Front
Automatic Retarder Control	Ground Level	Tow Pin, Rear
Batteries, 93-amp-hour, Low-maintenance, 12-volt (2)	Battery Disconnect	Traction Control System
Body Mounting Group	Engine Shutdown	Transmission, Six-speed, Automatic Power Shift, Electronic Control and Downshift Inhibitor, Reverse Neutralizer during Dumping, and Neutral Start Switch, Reverse Shift Inhibitor, Controlled Throttle Shifting, Directional Shift Management, Neutral Coast Inhibitor, Body-up Shift Inhibitor
Body Prop Cable	VIMS Dataport	Vandalism Protection Locks
Brake Release Motor for Towing	Lighting System	Vital Information Management System with True Weight Production Manager
Brake System	Back-up Lights, Halogen	
Oil-cooled, Multiple-disc, Front and Rear	Direction Signals and Hazard Warning (Rear Halogen)	
Parking	Headlights, Halogen, With Dimmer	
Secondary, Emergency	LH Ladder Light and Service Deck Lights	
Cab, ROPS	Stop and Tail Lights (LED)	
Ashtray	Under-hood Light	
Cigarette Lighter	Oil Change System, Quick Service	
Coat Hook	Reservoirs (Separate)	
Diagnostic Connector	Brake/converter/hoist	
Electric Window (Operator Only)	Steering	
Entertainment Radio Ready	Transmission	
Glass, Tinted		
Heater/defroster: 11 070 kCal (43,930 BTU)		
Horn		
Insulated and Sound Suppressed		
Integrated Object Detection System		
Light, Dome/courtesy		
Mirrors, Right and Left		
Quad-Gauge Panel		
Air Pressure		
Brake Oil Temperature		
Coolant Temperature		
Fuel Level		
Seat, Air Suspension		
Seat, Passenger, Non-suspension		
Seat Belts, 75 mm (3") wide retractable		
Speedometer		
Steering, Automatic Supplemental		
Steering Wheel, Tilt, Padded, Telescopic		
Storage Compartment		
Sun Visor		
Tachometer		
Transmission Gear Indicator		
VIMS Dataports (2)		
VIMS Keypad		
VIMS Message Center with Universal Gauge		
Windshield Wiper and Washer		

785C Optional Equipment

Optional equipment may vary. Consult your Cat dealer for details.

	kg	lb		kg	lb		kg	lb
Bodies	see Weight/Payload Calculation chart		Heater, fuel recirculation type, non-electric	2	5	Rim, spare for 33.00-R51 tire	889	1,960
Body extensions:			Heater, engine coolant and oil 120-volt external power source	2	5	Shutter group, inside mounted	265	585
Tail	665	1,465	Heater, engine coolant and oil 240-volt external power source	10	22	Starting system		
Sideboards ¹	798	1,760	Oil Renewal System	11	25	Air (TDI Turbine)	-5	-10
Body heat (exhaust)	36	80	Prelube system	24	53	Air (IR Turbine)	-17	-37
Body and tail extension liners ²						Variable pitch fan, Flexxaire	273	600
Full-length liner	7633	16,828				Variable speed fan, Rockford	182	400
Tail extension liner ³	338	745						
Grid liner ⁴	1145	2,525						
Fuel tank 2500 L (660 gal)	209	460						

¹ Increases capacity to 91 m³/119 yd³

² Minimum yield strength 900 mPa/9000 Bar/130,500 psi; 400 Brinell steel

³ Use with full liners when tail extension used

⁴ Covers rear third of body only

785C Mining Truck

For more complete information on Cat products, dealer services, and industry solutions, visit us on the web at www.cat.com

© 2010 Caterpillar Inc.
All rights reserved

Materials and specifications are subject to change without notice. Featured machines in photos may include additional equipment. See your Cat dealer for available options.

CAT, CATERPILLAR, SAFETY.CAT.COM, their respective logos, "Caterpillar Yellow" and the "Power Edge" trade dress, as well as corporate and product identity used herein, are trademarks of Caterpillar and may not be used without permission.

AEHQ6166 (12-2010)
Replaces AEHQ5320-03

