

994F

Wheel Loader



Engine

Engine Model	Cat® 3516B HD EUI	
Gross Power – SAE J1995	1176 kW	1,577 hp

Operating Specifications

Operating Weight	195 434 kg	430,858 lb
Rated Payload – Standard	35 tonnes	38 tons
Rated Payload – High Lift	32 tonnes	35 tons
Rated Payload – Extended High Lift	32 tonnes	35 tons
Rated Payload – Super High Lift	32 tonnes	35 tons

994F Wheel Loader

Powerful, responsive and rugged, the 994F sets the standard for high productivity and durability.

Power Train

The Cat® 3516B HD EUI engine delivers high horsepower to maximize productivity. Field proven for reliable performance in the most demanding applications, the 3516B HD EUI offers superior fuel efficiency, lower emissions, reduced engine noise and lower operating costs. **pg. 4**

Serviceability

The 994F is designed for quick and easy service. Most routine service can be accomplished from ground level and diagnostic ports have been clustered to improve efficiency. **pg. 14**

Structures

Structural components are the backbone of the 994F's durability. The heavy-duty box-section loader frame creates a durable, rugged machine. Solid steel lift arms resist twisting for maximum durability and reliability. **pg. 6**

Customer Support

Your Cat dealer offers a wide range of services that can be set up under a customer support agreement when you purchase your equipment. To help you get the best return on your investment, the dealer will help you choose a plan that can cover everything from machine and work tool selection to replacement. **pg. 15**

Hydraulics

Powerful Cat hydraulics deliver the power and control needed to keep material moving. Technologically advanced system provides precise, low-effort control and trouble-free operation. Unique filtration system prevents cross contamination. **pg. 8**

Designed for maximum productivity, the 994F builds on its productive tradition with innovations that enhance performance, reliability, durability and operator comfort to lower your cost per ton.



Buckets and Ground Engaging Tools

Cat buckets are designed for optimal loadability and structural reliability. A wide selection of buckets and ground engaging tools provides a match for every application and material condition to maximize productivity. **pg. 9**

Operator's Station

The ergonomically designed cab promotes a new level of operator spaciousness and comfort while making it easier for the operator to achieve maximum productivity over extended shifts. Controls are positioned within easy reach for superior control and reduced fatigue. **pg. 10**

VIMS® Vital Information Management System

Intelligent Cat® designed machine monitoring system provides critical machine health and payload data to keep the 994F performing at top production levels. **pg. 12**

Matched Systems

An efficient loading/hauling system starts with a perfect match. Your Cat dealer can help you build an optimum system to maximize truck payloads, minimize loading time, and lower your cost per ton. **pg. 16**

Safety

Cat has been and continues to be proactive in developing mining machines that meet or exceed safety standards. Safety is an integral part of all machine and systems designs. **pg. 17**



Power Train

Cat® power train delivers smooth, responsive performance and reliability in tough conditions.

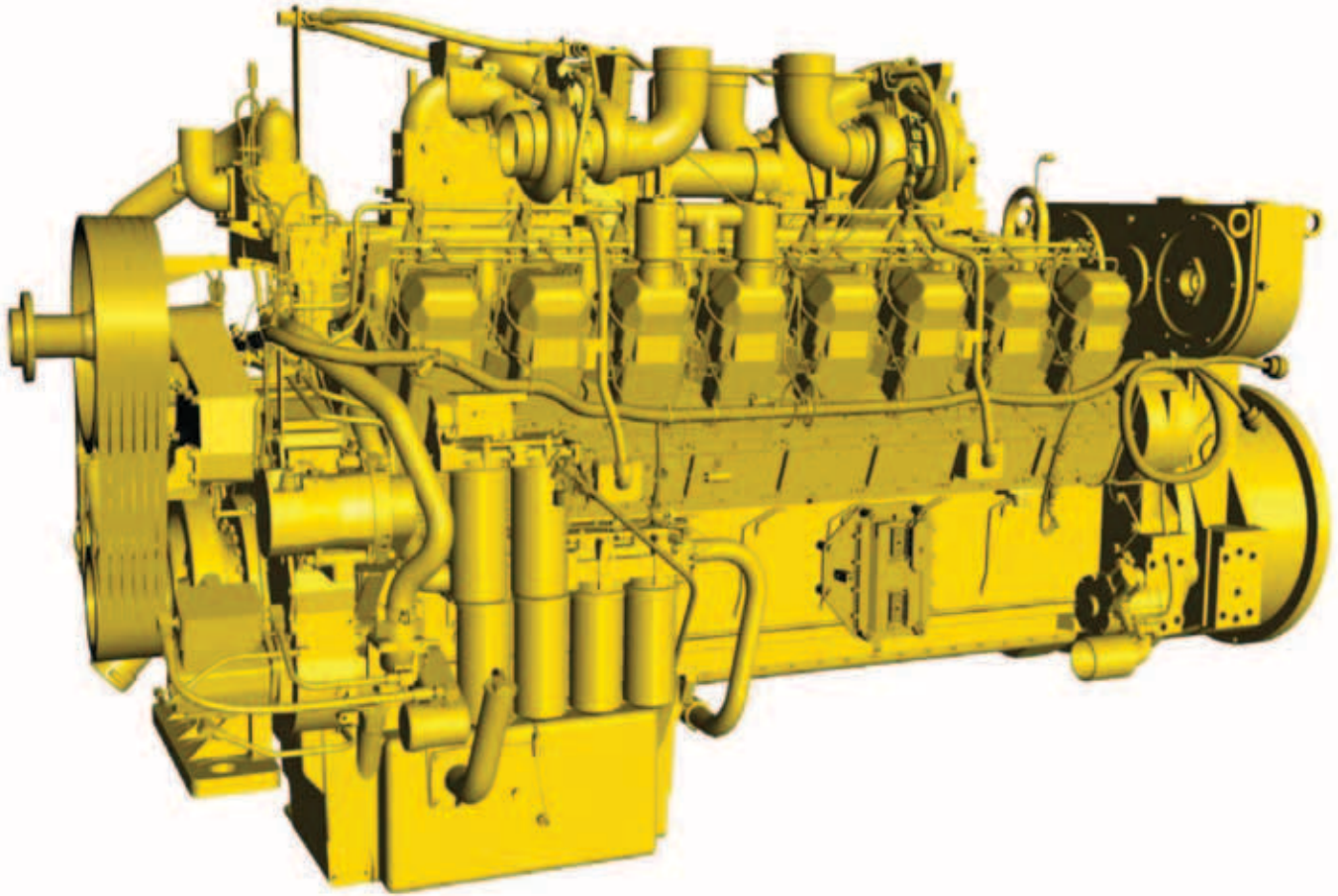

Engine. Field-proven Cat® 3516B HD EUI (High Displacement) turbocharged and aftercooled diesel engine delivers high power and reliability in the world's most demanding mining applications. The 3516B is a 16-cylinder, four-stroke design that uses long, effective power strokes for more complete fuel combustion and optimum efficiency.

Engine Features.

- Three-ring, two-piece pistons with high strength forged steel crowns and lightweight aluminum skirts.
- Steel-backed, copper-bonded aluminum bearings.
- Uniflow cylinder head design with four alloy steel valves per cylinder.

- High carbon steel alloy crankshafts with hardened journals.
- Pressure lubrication with full-flow filtered oil and heat exchanger oil cooler.
- Direct-electric 24-volt charging system.

High Torque Rise. With 32% torque rise, the 3516B HD EUI delivers high lugging forces during digging and acceleration in high rimpull conditions for maximum efficiency and fast cycle times.

Enhanced Life. High displacement, low rpm rating and conservative horsepower ratings mean more time in the field and less time in the shop.

Electronic Control Module (ECM).

The ECM is the electronic “brains” of the power system. Computerized system senses operating conditions and power requirements and adjusts engine for most efficient operation at all times.

Electronic Unit Injection (EUI).

The electronically controlled unit injection fuel system senses operating conditions and regulates fuel delivery for optimum fuel efficiency.

High Displacement (HD). The high displacement engine has a longer stroke, high power range and better fuel efficiency.

Advanced Diesel Engine Management.

ADEM™ system controls fuel injector solenoids to start and stop fuel injection for superior performance, greater reliability, cold start protection, automatic altitude compensation and air filter restriction indication.

Separate Circuit Aftercooler.

Allows aftercooler circuit to operate cooler than jacket water temperature for a denser air charge and greater combustion.

Ether Starting Aid. Ensures reliable start-up in extreme cold operating conditions.

Cat Planetary Power Shift

Transmission. Features heavy-duty components to handle the toughest jobs. Electronic controls allow smooth shifting for greater productivity, durability and longer component life.

Impeller Clutch Torque Converter (ICTC).

Electronically controlled impeller clutch torque converter provides maximum flexibility in regulating optimum rimpull in all conditions for smoother operation.

Inching Capability. Left brake pedal operation allows the operator to reduce rimpull to 25% then brake for more precise inching when approaching a truck or making directional changes.

Rimpull Control System.

Allows operator to adjust maximum rimpull from 100% down to 90, 85, 75 and 65% using a four-position dial while in first gear. Matching rimpull to job conditions provides greater traction in slippery or rough conditions for better performance and longer tire life.

Stable Design. Low mounted heavy-duty power train components ensure a stable machine.

Proven Reliability. The 994F power train has proven itself with the most reliable and durable components in the industry for the lowest operating cost per ton.



Torque. Torque is developed at the wheel, generating less stress and wear on the axle shafts.

Axles. The front axle is fixed, and the rear axle oscillates $\pm 10^\circ$, which allows either rear wheel to rise or fall 677 mm (26.7 in) while all wheels remain on the ground for maximum stability, greater traction and a more comfortable ride.

Differentials. Standard conventional differentials allow one tire to spin faster than the other, keeping developed torque out of the axles.

Axle Shafts. Free-floating axle shafts can be removed independently of the wheels and planetaries for quick and easy servicing.

U-Joints. Permanently lubricated for greater durability and long service life. Only the slipjoint requires manual lubrication.

Oil-Cooled Disc Brakes. Four-wheel, fully hydraulic oil-cooled multiple disc brakes are completely sealed and adjustment free. Two brake pedals allow standard braking with right pedal plus rimpull modulation braking with left pedal.

Brake Cooling. The brake oil cooler provides additional cooling to the brake discs for greater durability.

Filtration. Screens on the brake circuit minimize the risk of contamination.

Parking/Secondary Brake. Manual, spring-applied, multiple dry-disc brake is located on the front driveline for protection from contamination. Monitoring system alerts operator if transmission is engaged while parking brake is applied; if the pressure drops, the parking brake is automatically applied.

Engine Cooling. New Generation Modular Core Radiator (NGMR) significantly improves heat rejection through the use of copper cooling cores and improved flow characteristics.

Final Drives. The all-wheel-drive design features four planet carrier gears with planetary double reduction in each wheel for superior reliability. Planetaries can be removed independently of the wheels and brakes for quick and easy servicing.

Duo-Cone® Seals. Seals out dirt and contamination to extend component life.

Structures

Designed for maximum strength and durability in the harshest operating environments.

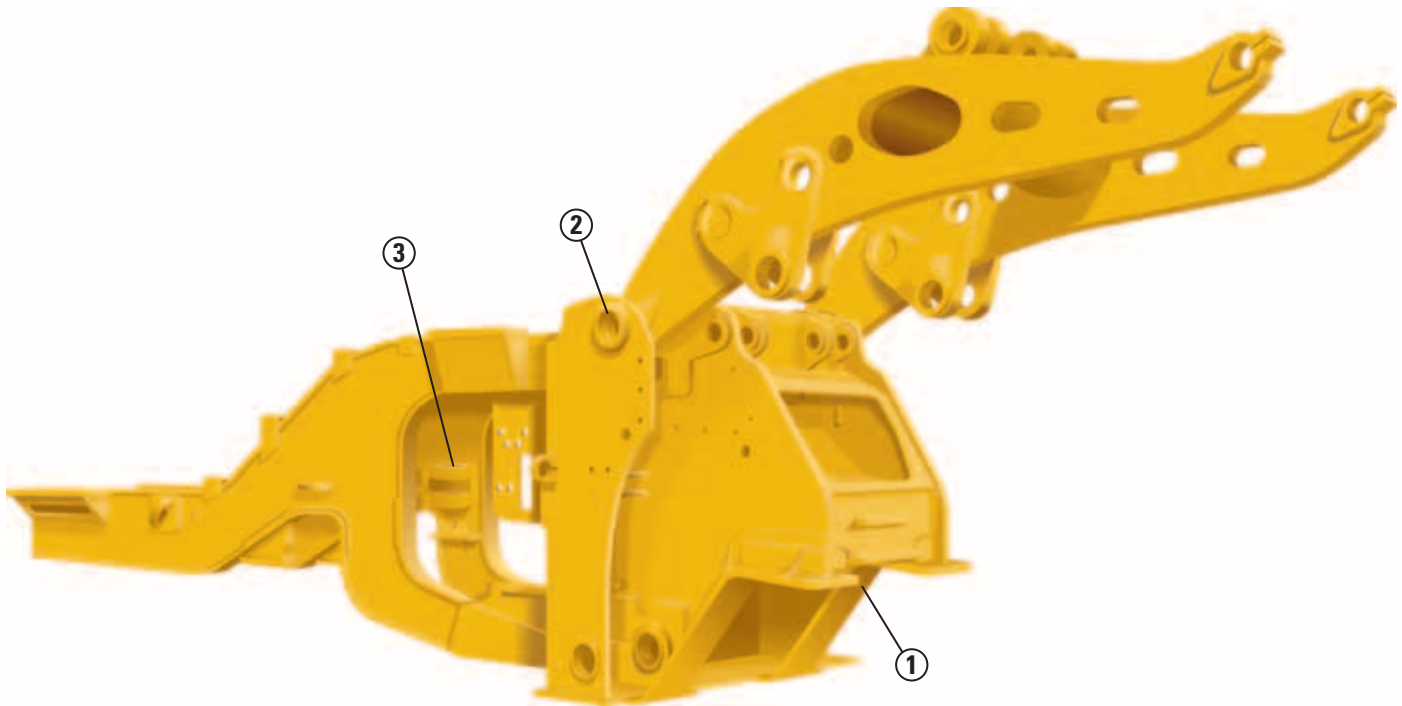

Robust Structures. The 994F front loader frame features robust structural components for outstanding durability in the toughest loading conditions. The frame is the backbone of the 994F's durability and is specifically designed and manufactured to withstand the higher forces required by the machine's increased payload rating.

Frame. The box-section rear frame, articulation hitch and four-plate loader tower are designed to resist torsional shocks, twisting forces and stresses generated during the loading cycle while protecting driveline and hydraulic system components.

1) Axle Mounting Area. Thicker axle pad castings joined by a box-boom structure provides added strength and stiffness in the axle mounting area.

2) Pivot Mount Castings. Castings in the lift arm pivot mounting area have been redesigned to better disperse stress loads for increased structural integrity.

3) Steering Cylinder Mounts. Steering cylinder mounts are thicker to more efficiently transmit steering loads into the frame.

Hitch Plate. The lower articulation hitch plate is larger for greater structural durability.

Z-bar Loader Linkage. Proven Z-bar loader linkage geometry delivers maximum productivity. Fewer pivot point and moving parts are designed to reduce maintenance costs.

Tilt Links. The pin joints at both ends of the tilt links have been changed to a greased pin design that is connected to an auto lube system. This will increase the reliability of these joints.

Breakout Force. Increased breakout force allows the loader to aggressively penetrate the bank.

Rackback. High rackback angle ensures greater material retention and less spillage.

Dump Speed. Controlled dumping speed protects the front linkage from excessive wear.

Lift Arms. The 994F's solid steel lift arms absorb high stresses generated during loading without sacrificing strength or durability. The linkage design provides an excellent view of the bucket edges, corners, and work area, allowing the operator to focus on productivity. The cross sectional area of the lift arms has been increased in several areas to improve durability.

1) Lift Arm Cross Member. A heat-treated lift arm cross member and improved weld procedures provide greater reliability and durability.

2) Lift Arm Mounting. Lift arm to front frame area has been redesigned to permit the use of a larger pin. The casting in this area of the front frame has been optimized to reduce stresses. The bolted joint at the lift arm to bucket pin location has been removed to improve reliability.

3) Stress-Relieved Lift Arms. Lift arms are stress relieved to eliminate residual stresses created during manufacturing and increase durability.

4) Auto Lube. Bucket to lift arm joint (B-pin) is automatically lubricated to increase reliability and reduce daily servicing.



Hydraulics

Cat hydraulics deliver the power and control needed to keep material moving.



Hydraulic System. Completely enclosed hydraulic system uses separate circuits for lift and tilt, steering and brake control. Separate circuits provide increased cooling and elimination of cross contamination, resulting in less downtime and greater productivity.

Lift and Tilt System. Three dedicated fixed displacement piston pumps and a fourth electronically controlled variable displacement piston pump deliver high reliability, efficiency and performance to the lift and tilt system. The variable displacement pump is only activated when additional hydraulic speed is needed.

Pilot Controls. Low-effort, pilot-operated finger-tip controls provide smooth, precise control of lift and tilt functions. Automatic lift kickout and return to dig detents deliver fast cycle times.

Steering System. The 994F features a load-sensing steering system with variable displacement piston pump for smooth, precise control. The revolutionary steering system integrates steering and transmission control functions into a single controller. Simple side-to-side movement of the STIC steer lever turns the machine right or left. Center point frame articulation allows the machine to articulate 40° to the left or right, permitting precise positioning in tight areas.

Filtration System. Advanced filtration system consists of additional screens and filters throughout the lift/tilt, steering and brake systems to maintain cleanliness and prevent downstream contamination. All are monitored electronically through VIMS™ system to simplify diagnostic troubleshooting and reduce downtime.

- Lift/tilt high pressure screens
- Steering high pressure screens
- Lift/tilt case drain filters
- Steering case drain filters
- Hydraulic case drain filters
- Front pump drive lube filter
- Front and rear brake oil screens

Buckets and Ground Engaging Tools

Cat buckets provide the flexibility to match the machine to the material and conditions.



High Productivity. Aggressive Cat bucket designs deliver unmatched productivity in the most demanding applications. 994F buckets have been redesigned for optimal loadability and structural reliability.

Rugged Design. Cat buckets are manufactured using shell-tine construction to resist twisting and distortion. A more aggressive spade edge increases bucket penetration and fill factors and provides better retention of loose material. An integral rock guard helps retain big loads for greater fill factors and optimum truck loading.

Spade Edge Rock Buckets. Spade edge rock buckets with bolt-on segments are designed to penetrate through the pile while leaving a smooth work floor. Shouldered, double-strap adapters allow easy change-out, and bolt-on segments extend base edge life.



Serrated Edge Coal Bucket.

Serrated edge bucket is recommended for low abrasion material loading where greater penetration is required. It does not use GET, thus eliminating the risk of iron falling into crushers. Replaceable serrated or straight edge is available if needed. Serrated edge is standard for the 36 m³ (47 yd³) coal bucket but can be added to the smaller buckets upon request.

Bucket Protection. Cat Ground Engaging Tools (GET) provide superior bucket protection for long life in the most punishing conditions. Built to absorb shock, impact, and abrasion, GET work and wear as a system to boost productivity and lower costs.

Tips. Tips extend bucket life in high wear applications.

Sidebar Protectors. Protect bucket corner and sides from wear in abrasive materials. Pin-on sidebars are reversible to extend wear life.

Edge Protectors. Protects bucket edge from wear in materials with high wear rates. Independently pinned for easy replacement without removing tips or adapters.

Wear Plates. Replaceable wear plates protect the bucket bottom. Bolt-on and weld-on wear plates protect the rear base edge from damage.

Operator's Station

Ergonomically designed for operator comfort, superior control and high productivity.



Spacious Cab Design. The 994F sets the standard for productivity with advanced controls and greater operator comfort. Features include outstanding visibility, excellent cab ventilation, interior sound levels below 75 dBA, trainer seat, cup holder, storage bin, radio ready and more. Improvements made for increased operator maneuverability and productivity.

Steering and Transmission Integrated Control System (STIC). Combines directional selection, gear selection and steering into a single lever for maximum responsiveness. Simple side-to-side motion turns machine right or left. Transmission shifting (forward/neutral/reverse) is controlled by the operator's fingers, and gear selection is controlled by the thumb. The integrated control system delivers low effort controls for smoother, faster cycles with less operator fatigue.

Left Brake Pedal. Allows the impeller clutch torque converter to modulate rimpull from 100% to 25%. After 25% is achieved, the brakes are engaged for improved control and smoother directional shifts. This improves speed control when approaching the truck.

Cat Comfort Series Seat. With air suspension and retractable seat belt, the seat is designed for comfort and support. Seat cushions reduce pressure on the lower back and thighs while allowing unrestricted arm and leg movement. The seat is six-way adjustable, and the retractable seat belt remains off the floor and is easy to reach for the operator. Armrests are height and tilt adjustable.



Trainer seat. The trainer seat consists of a padded seat and back with lap-style seat belt. When the trainer seat is not in use, the back can be folded down and used as a drink tray, and there is a storage compartment (room for a large lunch cooler) under the seat.

Seat Mounted Pilot Hydraulic Controls and Armrests. Provide low-effort control for enhanced comfort and stability. Controls and arm rests are fore, aft and height adjustable to accommodate operators of any size in a comfortable operating position. The levers are ergonomically designed for improved operator comfort.

Vital Information Management System. VIMS™ system is the standard display system that provides information on the machine's major components and systems. Gauge displays fuel tank level and temperatures for engine coolant, power train and hydraulic oil. Tachometer is an analog gauge with digital readout for gear selection. The Payload Control System is included in VIMS system.

Automatic Kickouts. Lift, lower and bucket tilt automatic kickouts are adjustable electronically from the cab.

Throttle Lock. Allows the operator to preset the engine speed, resulting in faster cycle times and increased productivity.

Rimpull Control System. Allows operator to match rimpull settings to job conditions with four-position dial. Operator can adjust maximum rimpull from 100% down to 90, 85, 75 and 65% while in first gear. Matching rimpull to job conditions provides greater traction in slippery or rough conditions for better performance and longer tire life.

Rimpull Control System Switch. Turns RCS on and off.

Other Features.

- outstanding viewing area
- excellent cab ventilation
- interior sound levels below 75 dB(A)
- standard coat hook
- intermittent wet-arm wipers (front and rear)
- radio ready
- CAES ready
- rear vision camera ready
- Product Link ready
- VIMS wireless ready

VIMS™ Vital Information Management System

Vital machine information at your fingertips.

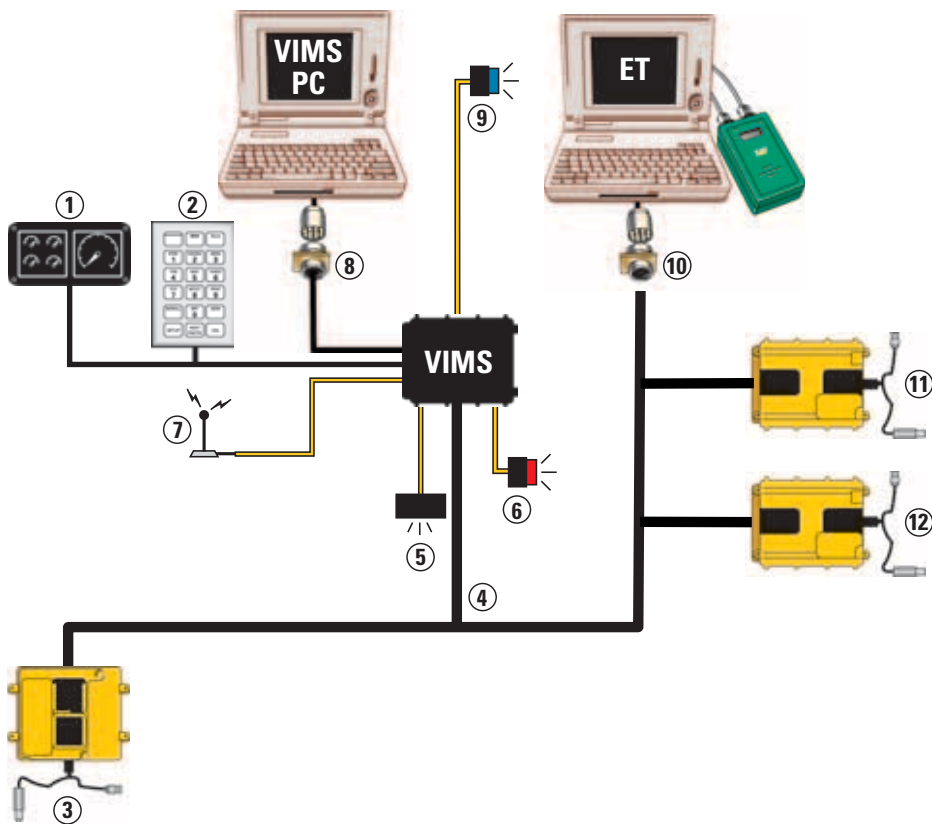

- 1 Gauge Cluster
- 2 Message Center and Keypad
- 3 ADEM III Engine Control Module
- 4 CAT Data Link
- 5 Action Alarm
- 6 Action Lamp
- 7 Radio System (optional)
- 8 Data Port (VIMS-PC)
- 9 Service Lamp
- 10 Diagnostic Connector (ET)
- 11 Transmission ECM
- 12 Implement

For the operator. VIMS system establishes a two-way communication between the operator and the machine. Real-time machine information allows the operator to make informed decisions that directly affect their safety, machine availability, and ultimately the productivity of the mine.

Maintenance. VIMS system provides maintenance personnel an overview of operator and machine performance. This allows maintenance managers and technicians the information necessary to maximize component life, reduce catastrophic failures, minimize unscheduled downtime and improve a mine's asset management.

Production. VIMS system collects the information a manager needs to determine equipment usage, future machine requirements, personnel performance, and productivity levels. Payload information can also be used as an accounting tool, an indicator of cycle time efficiency and truck over loading or under loading.

Integrated System Monitoring. Sensors located throughout the machine systems enable the VIMS system to quickly exchange and monitor information from all machine systems for efficient, high performance operation.

Advanced Diagnostics. VIMS system simplifies troubleshooting, reduces downtime and lowers operating costs by identifying abnormal conditions before they cause extensive damage.

Data Access. Monitoring and diagnostic information is stored on board until it can be downloaded for analysis. Data can be accessed through the message center, transmitted via optional radio and downloaded onto a computer for detailed analysis.

Machine Management. Maintenance and production personnel can download data and generate reports for better machine management. Data can be used to improve effectiveness of scheduled maintenance programs, maximize component life, improve machine availability, increase production and lower operating costs.

Gauge Cluster. Conveniently located gauge cluster maintains a constant display of vital machine functions, including:

- engine coolant temperature
- transmission oil temperature
- hydraulic oil temperature
- fuel level

Speedometer/Tachometer Module.

Monitors three systems: engine speed, ground speed and actual gear.

Keypad. Provides operator or service technician immediate access to current machine information, gauge values and stored data through the message center display.

Message Center. Displays payload bucket weights and messages requested by operator and advises operator of abnormal machine conditions.

Alert System. Three-category warning system alerts operator of abnormal machine health conditions.

Categories.

- Category I – Machine or system needs attention.
- Category II – Requires operator to evaluate and correct situation before continuing work.
- Category III – Immediate shutdown required to prevent serious damage to machine or system.

Production Management. The Wheel Loader payload system displays the current bucket weights along with the target of the truck being loaded, resulting in the ability to manage payloads. Also has the ability to track material and trucks for production analysis.

Data Storage. VIMS system stores up to 1200 cycles that would include date, time, truck ID, operator ID, material description, load site description, blast #, fuel used, bucket weight, bucket status and machine status.

VIMS PC Software. VIMS PC software, the off-board reporting software program, allows service personnel to download a complete record of machine health and productivity data to a laptop computer for diagnosis and analysis. Easy-to-use software enables service technicians and mine management to generate health and payload reports for more effective machine management.

VIMS Supervisor. On sites with multiple VIMS machines and where VIMS PC software is used to download all data, the use of VIMS Supervisor can aid in quick analysis of VIMS data. VIMS Supervisor can generate Health and Production report summaries for a single machine or an entire fleet. VIMS Supervisor is the drill down tool for fleet analysis using an existing “VIMS.mdb” database.

Serviceability

Less time spent on maintenance means more time on the job.



Easy Servicing. The 994F is designed for quick, easy servicing. Simplified access to service areas allows for quick servicing and ensures routine maintenance procedures are performed on time.

Ground-Level Access. Ground-level access to centralized lubrication points makes lube service quick and easy.

Air Cleaners. Dry-type air cleaners with primary and secondary elements, automatic dust ejector, and service indicator are positioned above the hood for easy access.

Pressure Test Ports. Hydraulic pressure test ports enable fast troubleshooting of major hydraulic circuits.

Next Generation Modular Radiator (NGMR). Modular design with removable cores for easy replacement and maintenance.

On-Board Diagnostics. Diagnostic connector allows quick troubleshooting of starting and charging functions.

Monitoring System. VIMS system notifies operator and service technicians of problems before failure and identifies location to minimize troubleshooting and reduce downtime. Features:

- Three-level warning system
- Data recording system
- Payload Control System
- Off-board analysis system

Auto Lube. Standard automatic lubrication system reduces maintenance time by automatically lubricating bearings in:

- lift and tilt cylinders
- upper and middle bucket tilt levers
- bucket pins
- steering cylinders
- rear axle trunnions
- fan drive and belt tightening pulleys
- upper and lower articulation hitch

Lubrication timing and duration can be easily set using the VIMS keypad.

Customer Support

Cat® dealers have what it takes to keep mining machines productive.

Machine Selection. Make detailed comparisons of the machines you are considering before you buy.

Purchase. Look past initial price. Consider the financing options available as well as day-to-day operating costs. This is also the time to look at dealer services that can be included in the cost of the machine to lower equipment owning and operating costs over the long run.

Financing. Your dealer is expert at arranging affordable financing options for all Cat products.

Customer Support Agreements. Cat dealers offer a variety of product support agreements and work with customers to develop a plan that meets specific needs. These plans can cover the entire machine, including work tools, to help protect your investments.

Product Support. You will find nearly all parts at your dealer parts counter. Cat dealers use a worldwide computer network to find in-stock parts to minimize machine downtime. Cat reman parts offer the same warranty and reliability as new products at cost savings of 40 to 70 percent.

Operation. Improving operating techniques can boost your profits. Your Cat dealer has training videotapes, literature, and equipment training courses to help you increase productivity.

Maintenance Services. Choose from your dealer's range of maintenance services when you purchase your machine. Repair option programs guarantee the cost of repairs up front. Diagnostic programs such as S•O•SSM coolant sampling and technical analysis help you avoid unscheduled repairs.



Replacement. Repair, rebuild or replace? Your Cat dealer can help you evaluate the cost involved so you can make the right choice.

www.cat.com. For more complete information on Cat products, dealer services, and industry solutions, visit us on the web at www.cat.com.

Matched Systems

An efficient loading/hauling system starts with a perfect match.

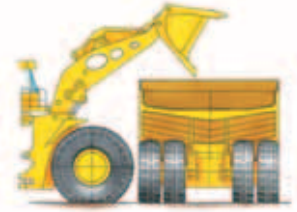

994F Standard Lift Pass Match		994F High Lift Pass Match		994F Extended High Lift Pass Match		994F Super High Lift Pass Match	
785C	4	789C	6	789C*	6	789C Coal body	6
789C	5	793C	7	793C*	7	793C Coal body	7

* The longer linkage makes it easier to load 789 and 793 Rock bodies and some Coal bodies.

Application Match. The standard 994F is sized to load the 150-ton 785C in four passes. The 994F High Lift and the Extended High Lift load the 195-ton 789C in six passes and the 240-ton 793C in seven passes. The 994F Super High Lift loads the 195-ton 789C coal body in six passes and the 240-ton 793C coal body in seven passes.



Efficient Combination. For full truck payloads with minimum loading time, an efficient loading/hauling system starts with a perfect match. Cat wheel loaders are matched with Cat C-Series mining trucks to maximize volume of material moved at the lowest operating cost per ton.

Bucket Selection. Selection of the right bucket width depends on penetration requirements and the loading target. Bucket sizes are matched to truck bed capacities for optimum loading efficiency and greater productivity.

Narrow Bucket. The narrower 5650 mm (222 in) buckets are optimally matched to load the Cat 785C; they are also sized for the 789C.

Wide Bucket. The wider 6220 mm (244 in) buckets are optimally matched to load the larger Cat 785C; they are also sized for the 793C.

Safety

Cat mining machines and systems are designed with safety as their first priority.

Product Safety. Cat has been and continues to be proactive in developing mining machines that meet or exceed safety standards. Safety is an integral part of all machine and systems designs.

SAE and ISO Standards. The 994F is designed to national and international standards. It has been tested and self-certified to comply with applicable SAE and ISO safety standards.

Integral ROPS/FOPS Cab. Mounted to the main frame to provide rollover and falling object protection. ROPS structure is designed as an extension of the loader frame.

Ladder/Secondary Egress. Two wide, stationary stairways with handrails on both sides allow three-point contact access to and from the machine.

Brake Systems. Four-corner oil-cooled braking system provides excellent control in slippery conditions. The service brakes are actuated by modulated hydraulic pressure, while secondary and parking brake functions are spring applied and hydraulic released. This system assures braking in the event of complete hydraulic failure.

Steering System. A twin double-acting cylinder steering system is designed to deliver precise control under all loading and underfoot conditions. The steering hydraulic system is separate from the main hydraulic system to prevent cross contamination and overheating from other sources.

Supplemental Steering System.

Provided using a ground driven pump is standard on the 994F. Backup steering system allows the operator to maintain control of the loader in the event of a failure in the main steering system.

Rear Vision Camera (optional). Located on top of the radiator in the center. Provides the operator 115° of field vision via a colored monitor located in the cab. Enables operator to see directly behind the loader.

Trainer Seat. The trainer seat makes training new operators in the correct operation of the loader easier. In addition, observing operational issues is easier.

Lock-out Panel. The panel is conveniently located on the left-hand side bumper in front of the ladder, allowing the operator/serviceman to reach the switches from ground level. In addition to the shutoff and lockout switches described below, this panel contains a VIMS port, stairway lights and hood lights switches.

Engine Shutoff Switch. An engine shutoff switch is located in the rear ground level lockout panel for immediate shutdown.

Transmission Lockout. A transmission lockout switch is located in the rear ground level lockout panel. Enables lockout of machine transmission to prevent gear engagement while the operator is not in the cab.

Starter Lockout. A starter lockout switch, when enabled, prevents the starter from being activated while service is being performed.

Toe Kicks. Toe kicks have been added to the rear platform. Prevents tools from falling off while servicing the machine.

Electrical System Disconnect. A battery disconnect switch, which is conveniently located near the left stairs, provides lockout of the electrical system for service work.

Service Center. Located at ground level to allow easy access for filling and draining machine fluid compartments.

Payload Policy. Safety is integral to maintaining the highest productivity in mining machine operation. The Cat 10/10 Payload Policy assures that steering and braking systems have sufficient capacity to perform at a 10% overload. VIMS, which is standard on the 994F, includes a payload indicator system. VIMS notifies the operator when the bucket is overloaded.

Standard Safety Features.

- Slip resistant surfaces
- Retractable, 75 mm (3 in) wide seat belts
- Wide-angle mirrors
- Hand rails
- Low interior sound level
- Trainer seat

SAFETY.CAT.COM™.

Engine

Engine Model	Cat® 3516B HD EUI	
Rated Speed	1,600 rpm	
Gross Power – SAE J1995	1176 kW	1,577 hp
Net Power – EEC 80/1269	1092 kW	1,463 hp
Net Power – ISO 9249	1092 kW	1,463 hp
Net Power – SAE J1349	1079 kW	1,447 hp
Bore	170 mm	6.7 in
Stroke	215 mm	8.5 in
Displacement	78 L	4,875 in ³
Peak Torque @ 1,100 rpm	8499 N•m	6,289 lb ft
Torque Rise	32%	

- Net power advertised is the power available at the flywheel when the engine is equipped with fan, air cleaner, muffler, and alternator.
- Net torque rise meets SAE J139.
- No engine derating required up to 3050 m (10,000 ft) altitude.

Operating Specifications

Operating Weight	195 434 kg	430,858 lb
Rated Payload – Standard	35 tonnes	38 tons
Rated Payload – High Lift	32 tonnes	35 tons
Rated Payload – Extended High Lift	32 tonnes	35 tons
Rated Payload – Super High Lift	32 tonnes	35 tons
Bucket Capacity Range	14-36 m ³	18.5-47 yd ³
Cat Truck Match – Standard	785C, 789C	
Cat Truck Match – High Lift	789C, 793C	
Cat Truck Match – Extended High Lift	789C, 793C	
Cat Truck Match – Super High Lift	789C, 793C	
Articulation Angle	40°	

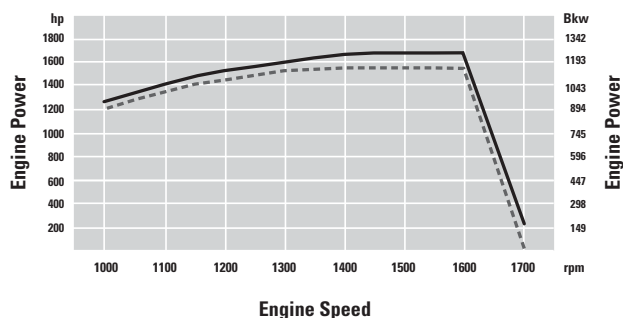
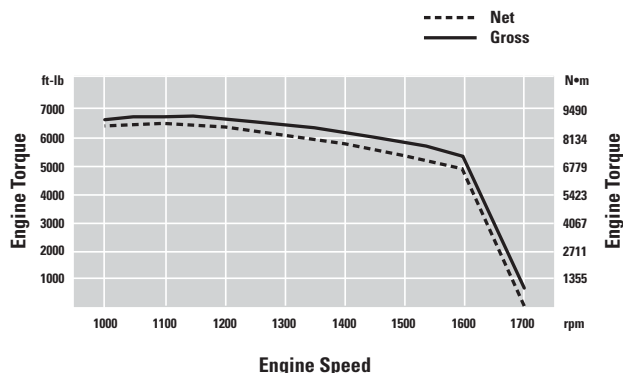

Transmission

Transmission Type	Cat planetary power shift	
Forward 1	7.7 km/h	4.8 mph
Forward 2	13.4 km/h	8.3 mph
Forward 3	22.5 km/h	14 mph
Reverse 1	8.5 km/h	5.3 mph
Reverse 2	13.2 km/h	8.2 mph
Reverse 3	24.8 km/h	15.4 mph
Direct Drive – Forward 1	Lock-up disabled	
Direct Drive – Forward 2	13.7 km/h	8.5 mph
Direct Drive – Forward 3	24 km/h	14.9 mph
Direct Drive – Reverse 1	8.5 km/h	5.3 mph
Direct Drive – Reverse 2	13.5 km/h	8.4 mph
Direct Drive – Reverse 3	25.6 km/h	16 mph

- Travel speeds based on two percent rolling resistance and 53.5/85-57 tires in converter drive.

Hydraulic System – Lift/Tilt

Lift/Tilt System – Circuit	Open	
Lift/Tilt System – Pump	3x Piston, fixed displacement	
Lift/Tilt – Pump	1x Variable, Piston	
Max Flow at 1,710 rpm (3x)	1370 L/min	362 gal/min
Relief Valve Setting – Lift/Tilt	32 800 kPa	4,750 psi
Cylinders – Lift/Tilt	Double-acting	
Lift Cylinder – Bore*	318 mm	13 in
Lift Cylinder – Stroke*	1660 mm	65.4 in
Tilt Cylinder – Bore*	267 mm	10.5 in
Tilt Cylinder – Stroke*	1140 mm	44.9 in
Number of Lift/Tilt Pumps	4	
Number of Lift Cylinders	2	
Number of Tilt Cylinders	2	

* 994F Standard Lift configuration

Hydraulic System – Pilot

Pilot System – Circuit	Closed	
Pilot System – Pump	Gear	
Max Flow at 1,710 rpm	154 L/min	40.7 gal/min
Relief Valve Setting – Pilot	2400 kPa	348 psi
Number of Pilot Pumps	1	

Hydraulic Cycle Time

994F High Lift Cycle Times

Rackback	5.5 Seconds
Raise	11.3 Seconds
Dump	3.1 Seconds
Lower Float Down (Empty)	3.5 Seconds
Power Down	6.7 Seconds

Service Refill Capacities

Fuel Tank	3833 L	1,013 gal
Cooling System	490 L	129 gal
Crankcase	286 L	75.5 gal
Transmission	350 L	92 gal
Differentials and Final Drives – Front	621 L	164 gal
Differentials and Final Drives – Rear	621 L	164 gal
Differential/Final Drives (each)	621 L	164 gal
Hydraulics – Lift/Tilt	390 L	103 gal
Hydraulics – Brake Cooling	36 L	9 gal
Hydraulics – Steering/Brake	208 L	55 gal
Pump Drive – Front	7 L	2 gal
Hydraulic System (including tank)	893 L	235.91 gal

Buckets

Bucket Capacities	14 – 36 m ³	18.5 – 47 yd ³
-------------------	------------------------	---------------------------

Axles

Maximum Single-Wheel Rise and Fall	677 mm	26.65 in
Front	Fixed	
Rear	Trunnion	
Oscillation Angle	±10°	

Brakes

Brakes	SAE J1473 OCT 90, ISO 3450:1992
--------	------------------------------------

Cab

Air Conditioning	Standard air conditioning system contains environmentally friendly R134a refrigerant
Cab – ROPS/FOPS	SAE J1394, SAE J11040 APR88, ISO 3471-1:1986, ISO 3471:1994

Cat cab with separate Rollover Protective Structure/ Falling Object Protective Structure (ROPS/FOPS) is standard in North America, Europe and Japan.

- ROPS meets SAE J394, SAE J1040 APR 88, ISO 3471-01:1986 and ISO 3471:1994 criteria.
- FOPS meets SAE J231 JAN 81 and ISO 3449:1992 Level II criteria.

Sound Performance	ISO 6394:1998
-------------------	---------------

The operator sound exposure Leq (equivalent sound pressure level) measured according to the work cycle procedures specified in ANSI/SAE J1166 OCT98 is 75 dB(A), for the cab offered by Cat, when properly installed, maintained and tested with the doors and windows closed.

- Hearing protection may be needed when operating with an open operator station and cab (when not properly maintained or doors/windows open) for extended periods or in noisy environment.
- The exterior sound pressure level for the standard machine measured at a distance of 15 m (49.2 ft) according to the test procedures specified in SAE J88 JUN86, mid-gear-moving operation, is 87 dB(A).
- The sound power level is 115 dB(A) measured according to the dynamic test procedure and conditions specified in ISO 6395:1988/Amd. 1:1996 for a standard machine configuration.

Vibration	EC 89/392 EEC
-----------	---------------

Hydraulic System – Steering

Steering System – Circuit	Closed	
Steering System – Pump	Piston, variable displacement	
Max Flow @ 1,710 rpm (6900 kPa) (2x)	884 L/min	234 gal/min
Relief Valve Setting – Steering	3100 kPa	4,500 psi
Number of Steering Pumps	2	

Dimensions

All dimensions are approximate.

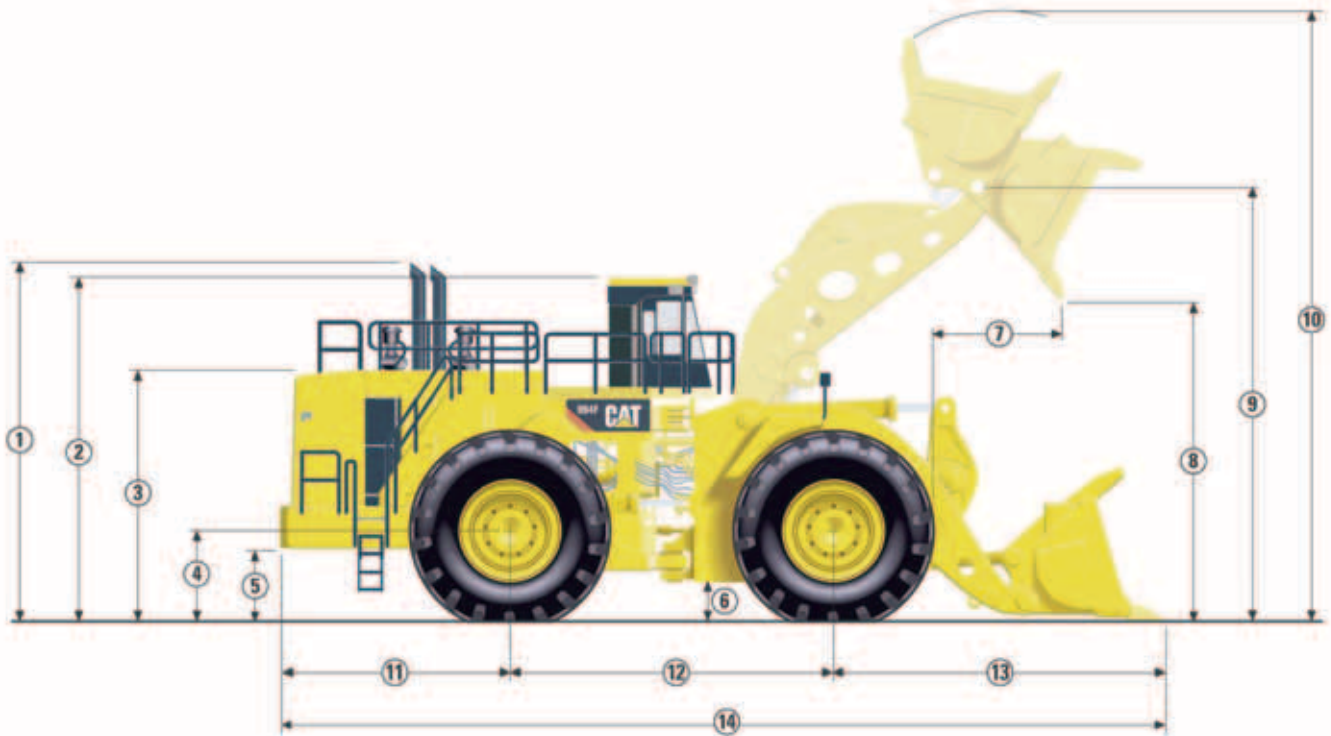

	Standard* 53.5/85-57 tires	High Lift** 53.5/85-57 tires	Super High Lift*** 58/85-57 tires
1 Height to Top of Exhaust Stacks	6988 mm (22.9 ft)	6988 mm (22.9 ft)	6747 mm (22.1 ft)
2 Height to Top of ROPS/FOPS	6736 mm (22.1 ft)	6736 mm (22.1 ft)	6494 mm (21.3 ft)
3 Height to Top of Hood	4833 mm (15.9 ft)	4833 mm (15.9 ft)	4591 mm (15.1 ft)
4 Height to Center of Axle	1829 mm (6 ft)	1829 mm (6 ft)	1587 mm (5.2 ft)
5 Bumper Clearance	1474 mm (4.8 ft)	1474 mm (4.8 ft)	1232 mm (4 ft)
6 Ground Clearance	811 mm (2.7 ft)	811 mm (2.7 ft)	569 mm (1.9 ft)
7 Reach at Maximum Lift/Dump	2309 mm (7.6 ft)	2764 mm (9.1 ft)	3400 mm (11.2 ft)
8 Clearance at Maximum Lift/Dump	5578 mm (18.3 ft)	6024 mm (19.8 ft)	7296 mm (23.9 ft)
9 Bucket Pivot at Maximum Lift	8140 mm (26.7 ft)	8479 mm (27.8 ft)	10 058 mm (33 ft)
10 Overall Height – Bucket Raised	10 933 mm (35.9 ft)	10 643 mm (34.9 ft)	14 372 mm (47.2 ft)
11 Length – Rear Axle to Bumper	4557 mm (15.0 ft)	4557 mm (15.0 ft)	4557 mm (15.0 ft)
12 Wheel Base Length	6400 mm (21.0 ft)	6400 mm (21.0 ft)	6400 mm (21.0 ft)
13 Length – Front Axle to Bucket Tip	5920 mm (19.4 ft)	6564 mm (21.5 ft)	8569 mm (28.1 ft)
14 Overall Length	16 877 mm (55.4 ft)	17 521mm (57.5 ft)	19 526 mm (64.1 ft)

* Standard machine equipped with 19 m³ (24.5 yd³) 222 in bucket.

** High Lift machine equipped with 18 m³ (23.5 yd³) 245 in bucket.

*** Super High Lift machine equipped with 36 m³ (47 yd³) 256 in bucket.

Bucket Capacity/Material Density Selection Guide

Rock Mining Applications only, for Coal Mining contact your Cat representative.

The following table provides a guideline for bucket selection based on various material densities and estimated fill factors. Based on the new ratings, fill factors are expected to be 110-120% in cohesive materials with easy digging, 100-110% in typical shot rock loading, and 90-100% in poorly shot rock with large rocks and difficult penetration. For many mining applications, the 994F standard lift is matched with the 19 m³ (24.5 yd³) rock bucket and the high lift is matched with the 17 m³ (22.5 yd³) rock bucket.

Bucket Capacity

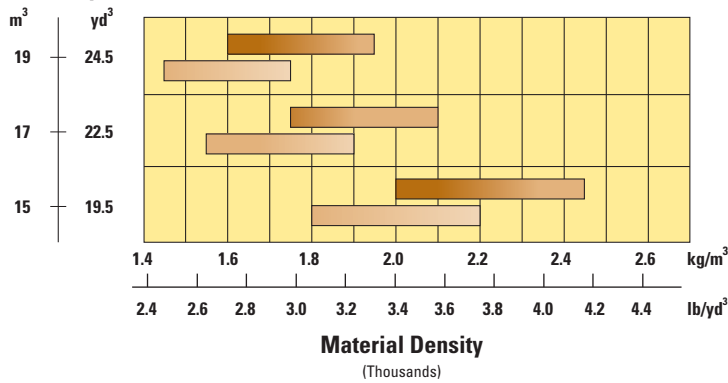

Bucket Fill Factor



Changes in bucket weight, including field installed wear iron, can impact rated payload. Consult your Caterpillar dealer for assistance in selecting and configuring the proper bucket for the application. The Caterpillar Large Wheel Loader Payload Policy is a guideline intended to maximize wheel loader structural and component life.

Operating Specifications – Standard Lift

For machines equipped with 53.5/85-57, 76 PR L-5 tires – see additional tables for other tire sizes

		Narrow Bucket (5640 mm/222 in)				Wide Bucket (6200 mm/244 in)		Coal Bucket (6200 mm/ 244 in)
		Spade Edge Rock Bucket Teeth & Segment				Spade Edge Rock Bucket Teeth & Segment		Straight Edge Coal Bucket Teeth & Segment
Rated capacity (\$)	m ³	14	15	17	19	18	19	31
	yd ³	18.5	19.5	22.5	25	23.5	25	41
Width (\$)	mm	5640	5640	5640	5640	6200	6200	6200
	ft/in	18' 6"	18' 6"	18' 6"	18' 6"	20' 4"	20' 4"	20' 4"
Struck capacity (\$)	m ³	11	12	14	15	14.5	15	27
	yd ³	14.4	15.7	18.3	19.6	19.0	19.6	35.3
Dump clearance at full lift and 45° discharge (\$)	mm	5771	5771	5663	5556	5663	5563	5635
	ft/in	18' 11"	18' 11"	18' 7"	18' 3"	18' 7"	18' 3"	18' 6"
Reach at full lift and 45° discharge (\$)	mm	2071	2071	2160	2266	2160	2278	2306
	ft/in	6' 9"	6' 9"	7' 1"	7' 5"	7' 1"	7' 6"	7' 6"
Reach with lift arms horizontal and bucket level	mm	4916	4916	5056	5206	5056	5210	5179
	ft/in	16' 1"	16' 1"	16' 7"	17' 0"	16' 7"	17' 1"	17' 0"
Digging depth (\$)	mm	108	108	108	108	108	108	63
	in	4"	4"	4"	4"	4"	4"	2"
Overall length (\$)	mm	16 604	16 604	16 744	16 894	16 744	16 898	16 830
	ft/in	54' 6"	54' 6"	54' 11"	55' 5"	54' 11"	55' 5"	55' 2"
Overall height with bucket at full raise (\$)	mm	10 719	10 719	10 866	10 911	10 636	10 621	10 960
	ft/in	35' 2"	35' 2"	35' 7"	35' 9"	34' 11"	34' 10"	39' 11"
Loader clearance circle with bucket in carry position (\$)	mm	12 668	12 668	12 704	12 742	12 965	13 002	13 073
	ft/in	41' 7"	41' 7"	41' 8"	41' 9"	42' 6"	42' 7"	42' 11"
Static tipping load straight*** (\$)	kg	130 783	131 140	130 266	128 499	127 909	126 522	129 295
	lb	288,327	289,114	287,187	283,292	281,991	278,933	285,046
Static tipping load at full 40° turn** (\$)	kg	113 391	113 684	112 784	111 091	110 539	109 241	111 719
	lb	250,188	250,835	248,849	245,113	243,895	241,032	246,298
Breakout force*** (\$)	kN	1134	1133	1055	989	1060	995	974
	lb	254,993	254,709	237,173	222,336	238,289	223,685	218,964
Operating weight*** (\$)	kg	191 899	192 039	192 699	193 779	193 999	194 729	195 169
	lb	423,064	423,373	424,828	427,209	427,694	429,303	430,273

(\$) Specifications rating conform to all applicable standards recommended by the Society of Automotive Engineers. SAE standard J732c governs loader ratings and is denoted in the chart by (\$).

* Dimensions are measured to the tip of the bucket teeth to provide accurate clearance data. SAE standard specifies the cutting edge.

** Static tipping load and operating weight shown are based on standard machine configuration with 53.5/85-57 tires, full fuel tank, coolant and lubricants.

*** Measured 102 mm (4 in) behind tip of cutting edge with the bucket hinge pin as pivot point in accordance with SAE J732c.

Changes in Standard Lift Specifications due to Tire Size

Dimensional changes

		50/80-57	52/80-57	55/80R57	53.5/85-57	58/85-57
Dump clearance at full lift and 45° discharge	mm	-136	-143	-89	0	+17
	in	-5	-6	-4	0	+0.7
Reach at full lift and 45° discharge	mm	+118	+143	+68	0	-15
	in	+5	+6	+3	0	-0.6
Reach with lift arms horizontal and bucket level	mm	+118	+143	+68	0	-15
	in	+5	+6	+3	0	-0.6
Digging depth	mm	+136	+143	+89	0	-17
	in	+5	+6	+4	0	-0.7
Overall length	mm	+105	+111	+70	0	-12
	in	+4	+4	+3	0	-0.5
Overall height with bucket at full raise	mm	-136	-143	-89	0	+17
	in	-5	-6	-4	0	+0.67
Total width over tires	mm	5305	5302	5509	5460	5524
	in	209	209	217	214	217

Weight changes

		50/80-57	52/80-57	55/80R57	53.5/85-57	58/85-57
Static tipping load straight	kg	-4234	-3339	+50	0	+327
	lb	-9,334	-7,361	+110	0	+721
Static tipping load at full 40° turn	kg	-3738	-2953	+44	0	+285
	lb	-8,241	-6,510	+97	0	+628
Operating weight	kg	-5388	-4256	+64	0	+416
	lb	-11,878	-9,383	+141	0	+917

Operating Specifications – High Lift

For machines equipped with 53.5/85-57, 76 PR L-5 tires – see additional tables for other tire sizes

		Narrow Bucket (5640 mm/222 in)				Wide Bucket (6200 mm/244 in)		Coal Bucket (6200 mm/ 244 in)
		Spade Edge Rock Bucket Teeth & Segment				Spade Edge Rock Bucket Teeth & Segment		Straight Edge Coal Bucket Teeth & Segment
Rated capacity (\$)	m ³	14	15	17	19	18	19	31
	yd ³	18.5	19.5	22.5	25	23.5	25	41
Width (\$)	mm	5640	5640	5640	5640	6200	6200	6200
	ft/in	18' 6"	18' 6"	18' 6"	18' 6"	20' 4"	20' 4"	20' 4"
Struck capacity (\$)	m ³	11	12	14	15	14.5	15	27
	yd ³	14.4	15.7	18.3	19.6	19	19.6	35.3
Dump clearance at full lift and 45° discharge (\$)	mm	6110	6110	6002	5895	6002	5902	5974
	ft/in	20' 0"	20' 0"	19' 8"	19' 4"	19' 8"	19' 4"	19' 7"
Reach at full lift and 45° discharge (\$)	mm	2632	2632	2721	2827	2721	2839	2867
	ft/in	8' 8"	8' 8"	8' 11"	9' 3"	8' 11"	9' 4"	9' 5"
Reach with lift arms horizontal and bucket level	mm	5556	5556	5696	5846	5696	5850	5819
	ft/in	18' 2"	18' 2"	18' 8"	19' 4"	18' 8"	19' 2"	19' 1"
Digging depth (\$)	mm	123	123	123	123	123	123	78
	in	5"	5"	5"	5"	5"	5"	3"
Overall length (\$)	mm	17 396	17 396	17 536	17 686	17 536	17 690	17 622
	ft/in	57' 0"	57' 0"	57' 6"	58' 0"	57' 6"	58' 0"	57' 10"
Overall height with bucket at full raise (\$)	mm	11 058	11 058	11 205	11 250	10 960	10 975	12 184
	ft/in	36' 3"	36' 3"	36' 9"	36' 11"	36' 0"	36' 0"	40' 0"
Loader clearance circle with bucket in carry position (\$)	mm	12 959	12 959	12 993	13 030	13 249	13 285	13 285
	ft/in	42' 6"	42' 6"	42' 7"	42' 10"	43' 6"	43' 7"	43' 7"
Static tipping load straight** (\$)	kg	108 695	108 926	108 111	106 543	105 978	104 795	107 068
	lb	239,631	240,140	238,344	234,887	233,641	231,033	236,044
Static tipping load at full 40° turn** (\$)	kg	93 575	93 757	92 914	91 399	90 871	89 753	91 770
	lb	206,297	206,699	204,840	201,500	200,336	197,871	202,318
Breakout force*** (\$)	kN	1091	1091	1015	951	1020	957	936
	lb	245,475	245,475	228,375	213,793	229,305	215,325	210,421
Operating weight** (\$)	kg	194 634	194 774	195 434	196 514	196 734	197 464	197 904
	lb	429,094	429,403	430,858	433,239	433,724	435,333	436,303

(\$) Specifications rating conform to all applicable standards recommended by the Society of Automotive Engineers. SAE standard J732c governs loader ratings and is denoted in the chart by (\$).

* Dimensions are measured to the tip of the bucket teeth to provide accurate clearance data. SAE standard specifies the cutting edge.

** Static tipping load and operating weight shown are based on standard machine configuration with 53.5/85-57 tires, full fuel tank, coolant and lubricants.

*** Measured 102 mm (4 in) behind tip of cutting edge with the bucket hinge pin as pivot point in accordance with SAE J732c.

Changes in High Lift Specifications due to Tire Size

Dimensional changes

		50/80-57	52/80-57	55/80R57	53.5/85-57	58/85-57
Dump clearance at full lift and 45° discharge	mm	-136	-143	-89	0	+17
	in	-5	-6	-3.5	0	+0.7
Reach at full lift and 45° discharge	mm	+118	+143	+68	0	-15
	in	+5	+6	+3	0	-0.6
Reach with lift arms horizontal and bucket level	mm	+118	+143	+68	0	-15
	in	+5	+6	+3	0	-0.6
Digging depth	mm	+136	+143	+89	0	-17
	in	+5	+6	+4	0	-0.7
Overall length	mm	+90	+94	+59	0	-12
	in	+4	+4	+2	0	-0.5
Overall height with bucket at full raise	mm	-136	-143	-89	0	+17
	in	-5	-6	-4	0	+0.7
Total width over tires	mm	5305	5302	5509	5460	5524
	in	209	209	217	214	217

Weight changes

		50/80-57	52/80-57	55/80R57	53.5/85-57	58/85-57
Static tipping load straight	kg	-3643	-2878	+43	0	+281
	lb	-8,031	-6,344	+95	0	+620
Static tipping load at full 40° turn	kg	-3217	-2541	+38	0	+248
	lb	-7,092	-5,602	+84	0	+548
Operating weight	kg	-5388	-4256	+64	0	+416
	lb	-11,878	-9,383	+141	0	+917

Operating Specifications – Extended High Lift

For machines equipped with 58/85-57 84 PR L-4 tires – see additional tables for other tire sizes

		Narrow Bucket (5640 mm/222 in)				Wide Bucket (6200 mm/244 in)		Coal Bucket (6200 mm/ 244 in)
		Spade Edge Rock Bucket Teeth & Segment				Spade Edge Rock Bucket Teeth & Segment		Straight Edge Coal Bucket Teeth & Segment
Rated capacity (\$)	m ³ yd ³	14 18.5	15 19.5	17 22.5	19 25	18 23.5	19 25	31 41
Width (\$)	mm ft/in	5640 18' 6"	5640 18' 6"	5640 18' 6"	5640 18' 6"	6200 20' 4"	6200 20' 4"	6200 20' 4"
Struck capacity (\$)	m ³ yd ³	11 14.4	12 15.7	14 18.3	15 19.6	14.5 19	15 19.6	27 35.3
Dump clearance at full lift and 45° discharge (\$)	mm ft/in	7199 23' 7"	7199 23' 7"	7097 23' 3"	6991 22' 11"	7097 23' 3"	6991 22' 11"	7063 23' 2"
Reach at full lift and 45° discharge (\$)	mm ft/in	2616 8' 7"	2616 8' 7"	2718 8' 11"	2824 9' 3"	2718 8' 11"	2824 9' 3"	2880 9' 5"
Reach with lift arms horizontal and bucket level	mm ft/in	6323 20' 9"	6323 20' 9"	6467 21' 3"	6617 21' 9"	6467 21' 3"	6617 21' 9"	6606 21' 8"
Digging depth (\$)	mm in	89 4"	89 4"	89 4"	89 4"	89 4"	89 4"	89 4"
Overall length (\$)	mm ft/in	18 254 59' 11"	18 254 59' 11"	18 398 60' 4"	18 548 60' 10"	18 398 60' 4"	18 548 60' 10"	18 536 60' 10"
Overall height with bucket at full raise (\$)	mm ft/in	12 153 39' 10"	12 153 39' 10"	12 300 40' 4"	12 346 40' 6"	12 055 39' 7"	12 071 39' 7"	13 280 43' 7"
Loader clearance circle with bucket in carry position (\$)	mm ft/in	13 442 44' 1"	13 689 44' 11"	13 485 44' 3"	13 530 44' 5"	13 731 45' 1"	13 776 45' 2"	13 864 45' 6"
Static tipping load straight** (\$)	kg lb	97 600 215,172	97 728 215,452	96 813 213,436	95 301 210,102	94 924 209,271	93 812 206,819	95 090 209,636
Static tipping load at full 40° turn** (\$)	kg lb	83 024 183,036	83 113 183,233	82 190 181,198	80 728 177,974	80 365 177,175	79 312 174,853	80 440 177,339
Breakout force*** (\$)	kN lb	1047.4 235,463	1046.9 235,351	973.7 218,885	908.7 204,288	977.9 219,831	918.0 206,371	897.0 201,646
Operating weight** (\$)	kg lb	204 834 451,582	204 974 451,890	205 634 453,346	206 714 455,727	206 934 456,212	207 664 457,821	208 104 458,791

(\$) Specifications rating conform to all applicable standards recommended by the Society of Automotive Engineers. SAE standard J732c governs loader ratings and is denoted in the chart by (\$).

* Dimensions are measured to the tip of the bucket teeth to provide accurate clearance data. SAE standard specifies the cutting edge.

** Static tipping load and operating weight shown are based on standard machine configuration with 53.5/85-57 tires, full fuel tank, coolant and lubricants.

*** Measured 102 mm (4 in) behind tip of cutting edge with the bucket hinge pin as pivot point in accordance with SAE J732c.

Operating Specifications – Super High Lift

Machines only equipped with 58/85-57 tires & Coal Bucket

		Coal Bucket (6500 mm/256 in)
		Serrated Edge Coal Bucket
Rated capacity (§)	m ³	36
	yd ³	47
Struck capacity (§)	m ³	30
	yd ³	39.2
Dump clearance at full lift and 45° discharge (§)	mm	7336
	ft/in	24' 0"
Reach at full lift and 45° discharge (§)	mm	3386
	ft/in	11' 1"
Reach with lift arms horizontal and bucket level	mm	7543
	ft/in	24' 9"
Digging depth (§)	mm	299
	ft/in	1' 0"
Overall length (§)	mm	19 504
	ft/in	63' 1"
Overall height with bucket at full raise (§)	mm	14 412
	ft/in	47' 3"
Loader clearance circle with bucket in carry position (§)	mm	14 262
	ft/in	46' 10"
Static tipping load straight** (§)	kg	83 444
	lb	183,962
Static tipping load at full 40° turn** (§)	kg	69 748
	lb	153,768
Breakout force*** (§)	kN	693
	lb	155,925
Operating weight** (§)	kg	211 970
	lb	467,313
Width over tires 58/85-57	mm	5524
	in	217

(§) Specifications rating conform to all applicable standards recommended by the Society of Automotive Engineers. SAE standard J732c governs loader ratings and is denoted in the chart by (§).

* Dimensions are measured to the tip of the bucket teeth to provide accurate clearance data. SAE standard specifies the cutting edge.

** Static tipping load and operating weight shown are based on standard machine configuration with 53.5/85-57 tires, full fuel tank, coolant and lubricants.

*** Measured 102 mm (4 in) behind tip of cutting edge with the bucket hinge pin as pivot point in accordance with SAE J732c.

Standard Equipment

Standard equipment may vary. Consult your Cat dealer for details.

ELECTRICAL

- Alarm, back-up
- Alternator, dual 80 amp
- Batteries, dry
- Converter, 10/15 amp, 24V to 12V
- Lighting system, (halogen, working lights, access and service platform lighting)
- Starting and charging system, 24V
- Starter lockout in bumper
- Transmission lockout in bumper

OPERATOR ENVIRONMENT

- Air conditioner
- Cab, sound suppressed and pressurized, separate external rollover protective structure (ROPS/FOPS) radio ready for entertainment, includes antenna, speakers and converter (12-volt 5-amp) and power port
- Cab, cleanout hose
- Cigar lighter, ashtray
- Coat hook
- Controls, lift and tilt function
- Heater, defroster
- Horn, air
- Instrumentation, gauges
 - Coolant temperature
 - Engine hour meter
 - Hydraulic oil temperature
 - Power train oil temperature
- Light, cab, dome
- Lunchbox, beverage holders
- Mirrors, rearview (externally mounted)
- Rimpull Control System
- Seat, Cat Comfort (cloth), air suspension, six-way adjustable
- Seat belt, retractable, 76 mm (3 in) wide
- STIC Control System
- Tinted glass
- Trainer seat with lap belt
- Transmission gear indicator
- Vital Information Management System (VIMS)
 - External data port, Integral Payload Control System
 - Message center, universal gauge
 - VIMS Keypad
- Wet-Arm wipers/washers (front and rear)
 - Intermittent front and rear wipers

POWER TRAIN

- Brakes, oil-cooled, multi-disc, service/secondary
- Crankcase guard is standard
- Driveline parking brake
- Engine, 3516B HD EUI (SCAC) diesel, turbocharged/aftercooled
- Fuel priming pump (electric)
- Ground level engine shutoff
- Precleaner, engine air intake (above hood)
- Radiator, Next Generation Modular (NGMR)
 - Power train oil coolers (2) air to oil, (2) water to oil
- Secondary steering
- Starting aid, ether, automatic
- Throttle lock, electronic
- Torque converter, Impeller Clutch (ICTC) with LUC, Rimpull Control System
- Transmission, planetary powershift, 3F/3R electronic control

OTHER

- Air tank, ECC compliant (EN286)
- Air line dryer
- Automatic bucket lift kickout/positioner
- Automatic lubrication system
- Base machine price includes a rim allowance
- Blower fan
- Couplings, Cat O-ring face seals
- Doors, service access (locking)
- Ecology drains for engine, radiator, hydraulic tank, steering and brake tank, and brake cooling tank
- Engine oil change system, high speed, Wiggins
- Fast fill fuel system (Shaw-Aero)
- Fuel tank, 4641 L (1,226 gal)
- Hitch, drawbar with pin
- Hoses, Cat XT™
- Hydraulic, steering and brake filtration/screening system
- Improved Service Center
- Mufflers (4)
- Oil sampling valves
- Premixed 50% concentration of extended life coolant with freeze protection to -34° C (-29° F)
- Rear access to cab and service platform
- Steering, load sensing
- Supplemental steering system
- Vandalism protection caplocks

Optional Equipment

With approximate changes in operating weights.

Optional equipment may vary. Consult your Caterpillar dealer for specifics.

	kg	lb		kg	lb
BUCKETS			POWER TRAIN		
Spade Edge			Crankcase guard	300	662
NARROW – 5650 mm (222 in)			Engine prelube	1	3
Rock – 14 m ³ (18.5 yd ³) (J800)	18 338	40,429	Engine oil renewal system	66	145
Rock – 15 m ³ (19.5 yd ³) (J800)	18 481	40,744	Sy-Klone turbine precleaner	11	25
Rock – 17 m ³ (22.5 yd ³) (J800)	18 217	40,162	RIMS		
Rock – 19 m ³ (25 yd ³) (J800)	20 197	44,526	914 mm (36") wide	1813	3,996
WIDE – 6220 mm (245 in)			1118 mm (44") wide		
Rock – 18 m ³ (23.5 yd ³) (J800)	20 167	44,460	with 126 mm (6") flange	1925	4,245
Rock – 19 m ³ (25 yd ³) (J800)	20 444	45,072	1194 mm (47") wide		
Straight Edge			with 126 mm (6") flange	1930	4,255
Coal – 32 m ³ (42 yd ³) (J700)	20 167	44,460	ELECTRICAL		
Serrated Edge			CAES, attachment ready	23	50
Coal – 36 m ³ (47 yd ³) (none)	20 444	45,072	VIMS, wireless II	0	0
GROUND ENGAGING TOOLS			Camera, rear vision	2	4
BUCKET TIPS*			OTHER		
Heavy duty – long – rock (J800)	88	193	Cab precleaner	2	5
Heavy duty – abrasion – rock (J800)	105	232	Product Link**	1	3
Heavy duty – penetration – rock (J800)	97	214			
Penetration – rock (J800)	54	120			
Heavy duty – long – coal (J700)	51	113			
Heavy duty – abrasion – coal (J700)	66	145			
BUCKET WINGS					
Low profile	350	772			

* Requires multiple quantities.

** Available mid-2005.

Mandatory Attachments (select one from each group)

Mandatory and optional equipment may vary. Consult your Caterpillar dealer for specifics.

	kg	lb		kg	lb
LIFT ARRANGEMENTS			RIMS		
Standard	0	0	914 mm (36") wide	0	0
High Lift	3186	7,024	1118 mm (44") wide		
Super High Lift	17 729	39,085	with 126 mm (6") flange	428	944
FUEL LINES			1194 mm (47") wide		
No heater	0	0	with 126 mm (6") flange	459	1,012
With heater	6	13	STARTERS		
Cold weather starting	32	71	Air start, turbine, Ingersoll	0	0
			Air start, turbine, TDI	0	0
			Electric- not recommended in ambient		
			temperatures below 0° C (32° F)	0	0

Notes

994F Wheel Loader

For more complete information on Cat products, dealer services,
and industry solutions, visit us on the web at www.cat.com

© 2010 Caterpillar
All Rights Reserved
Printed in U.S.A.

Materials and specifications are subject to change without notice.
Featured machines in photos may include additional equipment.
See your Cat dealer for available options.

AEHQ5640-03 (07-10)
Replaces AEHQ5640-02

CAT, CATERPILLAR, SAFETY.CAT.COM, their respective logos, "Caterpillar Yellow"
and the "Power Edge" trade dress, as well as corporate and product identity used
herein, are trademarks of Caterpillar and may not be used without permission.

