

924H

Wheel Loader

CATERPILLAR®



Cat® C6.6 Engine with ACERT™ Technology

Net power (SAE J1249) 96 kW 128 hp

EPA Tier 3, EU Stage III Compliant

Weight

Operating Weight 11 632 kg 25,644 lb

Buckets

Bucket Capacity 1.7-2.8 m³ 2.2-3.6 yd³

924H Features

Loader Linkage

Cat exclusive VersaLink™ Loader Linkage delivers strength and versatility to help you do more tasks, faster. The high lift linkage option takes you places others can't reach.

High Performance Power Train

Clean, quiet operation with superior power.

Powerful Hydraulic System

System senses work demand and adjusts flow and pressure to match for precise, efficient control.

Comfortable Cab

Large, spacious cab and low-effort, ergonomic joystick controls let you concentrate on your work.

Work Tools

Make your 924H the most versatile machine on the jobsite with Caterpillar's broad range of work tools.



Contents

VersaLink Loader Linkage	3
Power Train	4
Hydraulics	5
Operator Station	6
Work Tools	7
Serviceability	8
Customer Support	8
Specifications	9
Standard and Optional Equipment	17

The Cat® 924H Wheel Loader leads the industry in operator comfort, performance and versatility. Size, power, performance and work tool interchangeability make this machine ideal for a wide range of jobs. Fast cycle times help you move more material. Large spacious cab with joystick control keeps you comfortable throughout the work day, allowing you to get more done. Loader design delivers strength and durability with superior control and unmatched versatility. Discover how much more you can get done with the new 924H.

VersaLink™ Loader Linkage

Loader design delivers unmatched versatility.

Linkage Design

The Cat exclusive VersaLink™ design provides toolcarrier controllability, versatility and parallel lift with the strength, durability and speed of Z-Bar linkage. The 924H can be configured in several ways:

- Equipped with a Quick Coupler for quick and easy work tool changes providing optimum utility and versatility.
- Equipped with pin-on work tools, such as a bucket, for a dedicated wheel loader application with exceptional breakout force, tipping load and dump height.
- Equipped with the High Lift VersaLink loader linkage option for special applications that require more reach and lift height.

Loader Performance

The VersaLink loader linkage is designed for exceptional loader performance in a wide range of applications, offering:

- Simultaneous tilt, lift and auxiliary hydraulics function for precise control of the work tool.
- Increased breakout force to shorten cycle times and increase bucket fill factors.
- Higher dump clearance for working in “high target” situations that ordinary loaders cannot.
- More dig depth for better excavation performance, even when equipped with larger tires.
- Greater rackback angle for improved material retention, resulting in higher productivity.
- Greater dozing angle for improved control of material when fine grading.

Parallel Lift

Parallel lift simplifies working with palletized or stacked material. Operators can concentrate on material placement while the load automatically remains parallel throughout the lift range. And, like a toolcarrier, the 924H can easily manipulate loads at all heights.

High Lift Version

Special applications call for special equipment. The optional High Lift VersaLink loader linkage provides an additional clearance of 507 mm (20 in) and is ideal for jobs that require higher lift of lighter materials. The high lift VersaLink is available in both pin-on and quick coupler versions.





Power Train

Delivers maximum rimpull to the ground and full power to loader hydraulics.

Cat Engine

The Cat C6.6 engine provides cleaner, quieter operation while delivering superior performance and durability. The 96 kW (128 hp) rated net power engine meets all worldwide emissions standards and features: flatter power curve for outstanding response in the working RPM range (1,900 to 2,300), noise reduction technologies for up to 5 dB reduction, and patented ACERT™ Technology combined with common rail fuel system, smart waste gate turbocharger and crossflow head design for reduced emissions.

Cat Axles

Heavy-duty axles feature hardened gears and bearings for durable performance. Rear axle oscillates up to 12 degrees to help assure four-wheel ground contact for optimum traction and stability. Optional front and rear Limited Slip Differentials enable outstanding traction in poor underfoot conditions.

Cat Transmission

Rugged Cat transmission uses heavy-duty components for durable and reliable operation. The operator can choose between manual shift and two autoshift modes, Performance or Economy. Performance mode provides maximum acceleration while the economy mode increases fuel economy and improves operator comfort.

Hydraulics

Modular system provides high efficiency with low effort, precise control.



Load-Sensing Hydraulics

Modular hydraulic system delivers precise control with low effort operation. This load-sensing, variable flow system senses work demand and adjusts flow and pressure to match. This allows full hydraulic forces at any engine speed for delicate jobs in tight areas. Combined with the VersaLink linkage, the hydraulic system allows simultaneous lift, tilt and auxiliary hydraulic function.

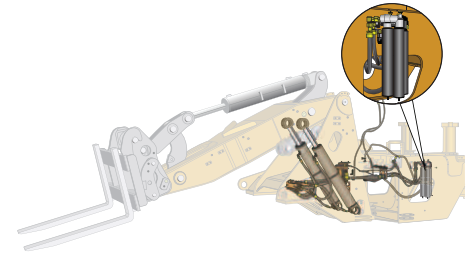

Auxiliary Hydraulics

Auxiliary hydraulics provide unparalleled versatility allowing you to select the configuration that best suits your application. Third function only or packaged with fourth enables the use of almost all work tools.

Optional Joystick with Integrated Third Function Controls

An optional joystick combines lift and tilt functions with transmission controls and third function auxiliary hydraulic controls in one ergonomic joystick. This allows the operator to maintain control of the load linkage while operating hydromechanical tools. The system can operate in two modes: the Work Tool and Continuous Flow mode, which allows bi-directional flow to be controlled with a thumbwheel, and the Continuous Flow mode, which provides infinitely variable flow to tools with hydraulic motors.

Ride Control System

The optional Ride Control System provides a comfortable ride and excellent material retention.

Four nitrogen charged accumulators set to different pressures enable optimum cushioning over uneven terrain for all loads and speeds.

The system operates in Automatic; as the loader ground speed exceeds 5 kph (3 mph) the system will activate, below 5 kph (3 mph) the system is off, providing maximum lift power.

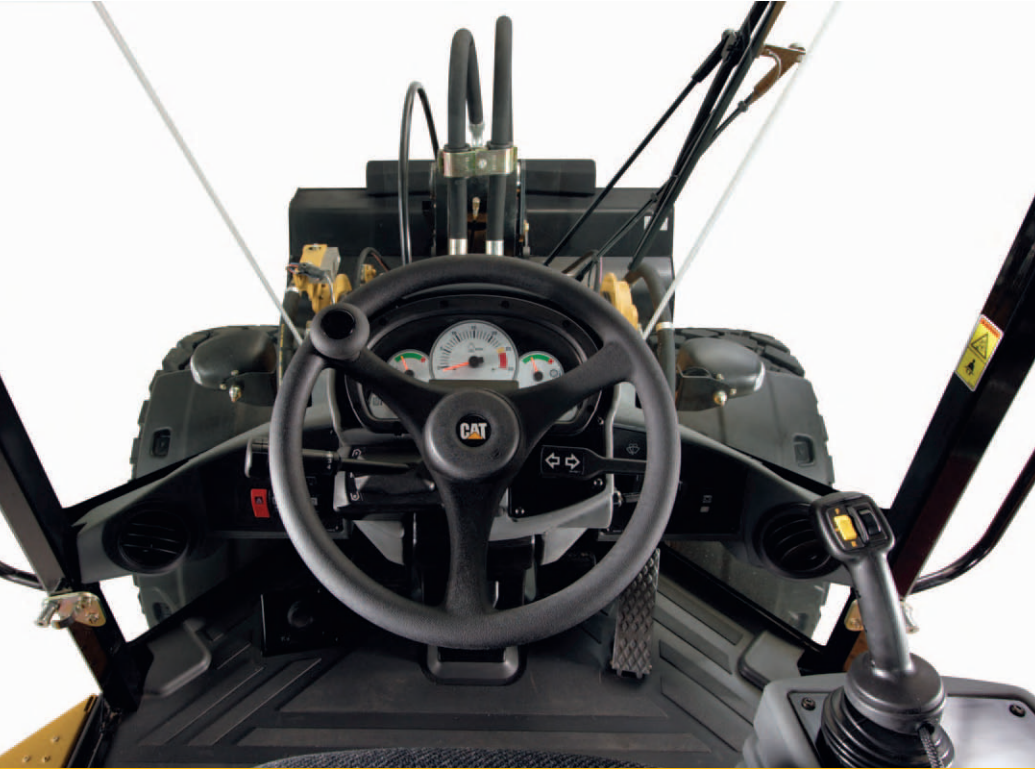

Operator Station

Superior comfort keeps you productive, all day long.

Experience comfort and convenience in the H-Series cab. The spacious interior and ergonomic controls keep you comfortable throughout the work day. Choose the seat that meets your needs – the standard, fully adjustable seat or the optional Cat Contour seat for added adjustment and air suspension. The two-door design lets you enter and exit from either side of the machine and wide, serrated steps provide stable footing. Both doors lock open 180 degrees and feature sliding glass windows for better communication with workers on the ground. Large flat glass windows provide excellent visibility all around the machine. The rear window features a standard electric defroster.

Controls

Low effort, ergonomic joystick controls provide easy operation of lift and tilt functions. The standard joystick features an integrated directional control switch for added convenience. The operator programmable transmission neutralizer can be set in seconds optimizing brake effort for all applications.

Instrument Panel

The sealed instrument panel with easy to read white faced gauges and indicators keeps the operator informed of system conditions. The large LED readout provides ground speed and other critical information.

Optional Rear View Camera

This work area visual enhancement system uses a closed circuit video monitoring system. Up to three cameras can be mounted on the machine frame. Objects can be viewed on a color LCD monitor in the cab.

Work Tools

Do more jobs with one machine with Cat Work Tools.

The Right Tool for the Job

The wide variety of work tools offered by Caterpillar makes the 924H one of the most versatile machines on the jobsite. Work tools can be changed quickly and easily with the machine's quick coupler system. A switch in the cab activates a hydraulic cylinder for positive tool engagement and disengagement.

Bucket Work

With exceptional rimpull and high breakout and lift forces, the 924H delivers strong performance as a bucket loading machine. A wide range of Cat buckets are available including:

- General purpose – 1.8 m³ (2.4 yd³) and 2.1 m³ (2.75 yd³)
- Penetration
- Light material
- Multi purpose
- Side dump
- High dump
- Wood chip
- Top clamp

Material Handling

The exceptional visibility and heavy-lift capabilities of the 924H let you work quickly and efficiently in material handling applications. A wide range of tools are available:

- Standard width carriage with pallet forks – 1220 mm (48 in), 1370 mm (53 in) and 1524 mm (60 in)
- 2440 mm (96 in) wide carriage with 1830 mm (72 in) or 1524 mm (60 in) tines
- Offset forks for improved tip visibility
- Material handling arm
- Log and lumber forks with a variety of top clamp choices

Special Applications

Caterpillar also offers other work tools designed to meet specific job requirements:

- Dozer blades
- Snow plows
- Hydraulic brooms
- Asphalt cutter
- Loader rakes

Work tool availability varies by region.



Serviceability

Easy access and minimal maintenance requirements keep your machine on the job.



Convenient service features make maintenance easy.

All service points are accessible from ground level on the right side of the engine. Gull-wing doors with gas struts lift for exceptional access to filters and service points. Extended service intervals reduce service time and increase machine availability.

- Sight gauges let you easily check radiator coolant, hydraulic oil and transmission oil levels as well as engine air filter restriction without opening the air cleaner.
- Standard pressure taps allow quick diagnosis of the entire hydraulic system.
- S•O•SSM ports make oil sampling quicker, cleaner and provide the best oil sample for analysis.
- Spin-on filters for engine oil, transmission oil and hydraulic oil are vertically mounted for easier servicing.
- 924H features a standard electronic fuel prime pump.
- Sequentially placed radiator and oil coolers are easy to access.
- Swing-out cooling fan allows quick and easy cleaning and servicing of the radiator. The fan is hydraulically driven and separate from the engine compartment for low noise operation.
- Optional reversing fan cleans screens without interrupting machine operation.

Customer Support

Unmatched support makes the difference

Your Cat dealer is ready to assist you with your purchase decision and everything after.

- Make comparisons of machines, with estimates of component life, preventative maintenance and cost of production.
- Financing packages are flexible to meet your needs.
- Your Cat dealer can evaluate the cost to repair, rebuild and replace your machine, so you can make the right choice.
- For more information on Cat products, dealer services and industry solutions, visit us at www.cat.com.



924H Wheel Loader Specifications

Engine

Rated net power @ 2,300 rpm	96 kW	128 hp
Model	Cat® C6.6	
SAE J1349	96 kW	128 hp
ISO 9249 (1997)	97 kW	130 hp
EEC 80/1269	97 kW	130 hp
Max. net power @ 2,000 rpm	103 kW	138 hp
SAE J1349	103 kW	138 hp
ISO 9249 (1997)	104 kW	139 hp
EEC 80/1269	104 kW	139 hp
Bore	105 mm	4.13 in
Stroke	127 mm	5 in
Displacement	6.6 L	403 in ³
Net torque	658 N·m	485 ft·lb
Peak torque	673 N·m	496 ft·lb

- Net Power ratings are tested at the reference conditions for the specified standard.
- Net power shown is the power available at the flywheel when the engine is equipped with alternator, air cleaner, muffler and fan at minimum speed.
- No derating required up to 3000 m (9,843 ft) altitude. Auto derate protects hydraulic and transmission systems.
- When the fan is at maximum speed, Rated Net Power is 82 kW (109 hp) and Maximum Net Power is 92 kW (123 hp) at the flywheel per the SAE reference conditions.
- The Caterpillar® C6.6 engine meets Tier 3 off-highway emission regulations.

Engine Torque

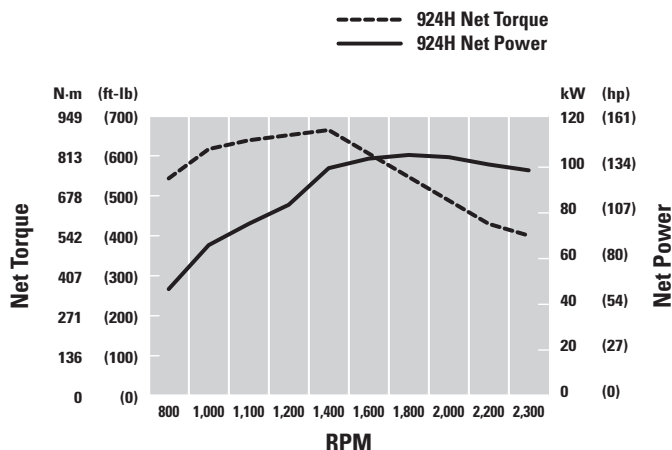

Buckets

Bucket capacities	1.7 m ³ - 2.8 m ³	2.2 yd ³ - 3.6 yd ³
-------------------	--	--

Weights

- | | | |
|------------------|-----------|-----------|
| Operating weight | 11 632 kg | 25,644 lb |
|------------------|-----------|-----------|
- Specifications shown are for 924H with optional counterweight, standard lubricants, full fuel tank, deluxe cab, Limited Slip rear axle with heavy duty brakes, additional guarding, 1.8 m³ (2.4 yd³) bucket with bolt-on cutting edge, 80 kg (176 lb) operator and 20.5 R25 radial (L-3) XHA tires.

Steering

Steering articulation	40°	40°
Minimum turning radius (over tire)	5070 mm	200 in
Steering angle, each direction	40°	40°
Steering cylinders, two, bore	70 mm	2.75 in
Hydraulic output at 2,300 engine rpm and 6900 kPa (1,000 psi)	106 L/min	27.7 gal/min
Maximum working pressure	20 685 kPa	3,000 psi

Loader Hydraulic System

Output at 2,300 engine rpm and 6900 kPa (1,000 psi) with SAE 10W oil at 65° C (150° F)	152 L/min	39.5 gal/min
Hydraulic cycle time	8.9 Seconds	
Pump flow – implement pump	152 L/min	40.15 gal/min
Relief pressure – implement pump	258.9 bar	3,755 psi
Maximum working pressure	25 900 kPa	3,755 psi
Hydraulic cycle time	8.9 Seconds	
Raise	5.1 Seconds	
Dump	1.4 Seconds	
Lower, empty, float down	2.4 Seconds	
Total	8.9 Seconds	
Lift cylinders, double acting:		
Bore	101.6 mm	4 in
Stroke	810 mm	31.9 in
Tilt cylinder, double acting:		
Bore	133.4 mm	5.25 in
Stroke	945 mm	37.2 in

Service Refill Capacities

Fuel tank	225 L	59.4 gal
Cooling system	40 L	10.6 gal
Crankcase	15 L	4.0 gal
Transmission	23 L	6.1 gal
Differentials and final drives:		
Front	21 L	5.5 gal
Rear	21 L	5.5 gal
Hydraulic system (including tank)	148 L	39 gal
Hydraulic tank	70 L	18.5 gal

924H Wheel Loader Specifications

Transmission

Standard transmission		38.5 km/h	23.9 mph
max travel speeds			
Forward	1	6.7 km/h	4.2 mph
	2	12.2 km/h	7.6 mph
	3	21.8 km/h	13.5 mph
	4	38.5 km/h	23.9 mph
Reverse	1	6.7 km/h	4.2 mph
	2	12.2 km/h	7.6 mph
	3	21.8 km/h	13.5 mph
Optional low speed transmission		39 km/h	24.2 mph
max travel speeds			
Forward	1	3.7 km/h	2.3 mph
	2	7.5 km/h	4.7 mph
	3	19.6 km/h	12.2 mph
	4	39 km/h	24.2 mph
Reverse	1	4.1 km/h	2.5 mph
	2	8.1 km/h	5 mph
	3	21.2 km/h	13.2 mph

Tires

Size	20.5 R25 Radial (L-3)	
Tread width	1880 mm	6 ft 3 in

- Choice of:
 - 17.5-25, 12PR (L-2)
 - 17.5-25, 12PR (L-3)
 - 17.5 R25, radial (L-2)
 - 17.5 R25, radial (L-3)
 - 20.5-25, 12PR (L-2)
 - 20.5-25, 12PR (L-3)
 - 20.5 R25, radial (L-2/L-3)
 - 550/65 R25, radial (L-3)
- Other tire choices are available, contact your Cat® Dealer for details.
- In certain applications, the loader's productive capabilities may exceed the tire's tonnes-km/h (ton-mph) capabilities. Caterpillar recommends that you consult a tire supplier to evaluate all conditions before selecting a tire model.

Cab

ROPS	SAE J1040 MAY94, ISO 3471-1994	
FOPS	SAE J/ISO 3449 APR98 Level II, ISO 3449 1992 Level II	

- Caterpillar cab and Rollover Protective Structure (ROPS) are standard in North America and Europe.
- When properly installed and maintained, the cab offered by Caterpillar, when tested with doors and windows closed as per work cycle procedures specified in ANSI/SAE J1166 May 90, results in operator sound exposure Leq (equivalent sound pressure level) of 74 dB(A).

Operating Specifications

Static tipping load (full turn)	7276 kg	16,041 lb
Reach – full lift/45 degree dump angle	992 mm	3 ft 3 in
Dump clearance – full lift/45 degree dump angle	2828 mm	9 ft 3 in
Articulation angle	40°	40°

Dimensions with Bucket

All dimensions are approximate. Dimensions may vary with bucket. Refer to Operating Specifications.

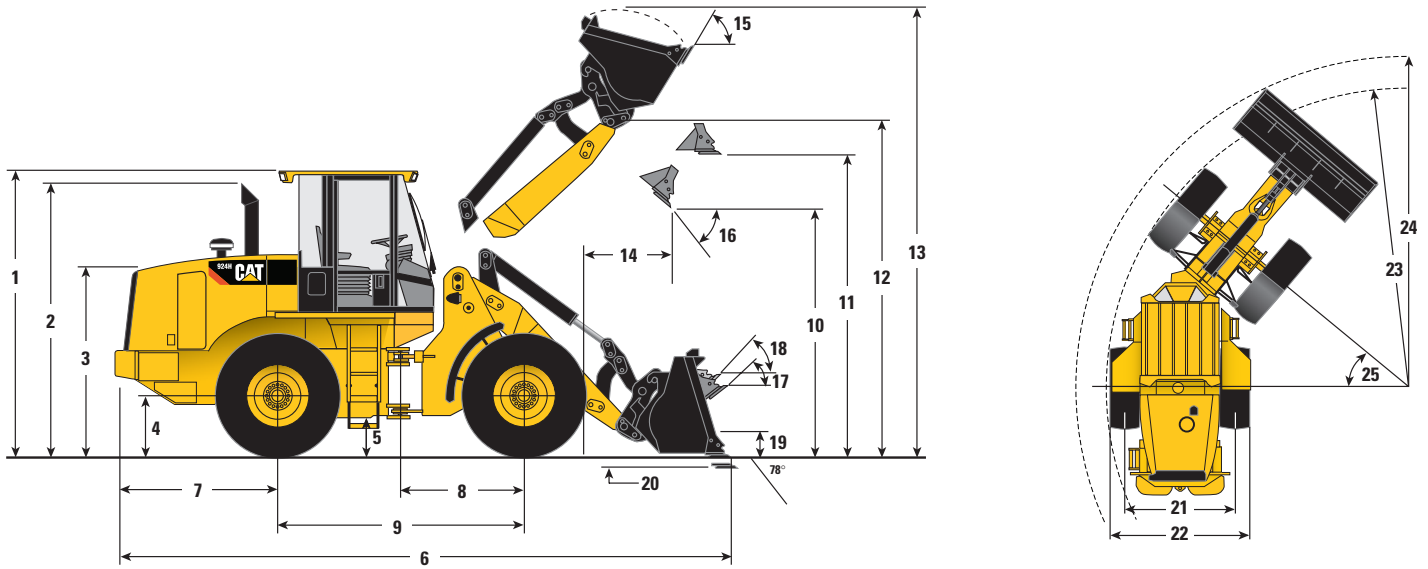

	Standard VersaLink		High Lift VersaLink	
1	Height to top of ROPS/FOPS	3227 mm (10 ft 7 in)	3226 mm (10 ft 7 in)	
2	Height to top of exhaust stack	3211 mm (10 ft 6 in)	3210 mm (10 ft 6 in)	
3	Height to top of hood	2219 mm (7 ft 3 in)	2218 mm (7 ft 3 in)	
4	Height to center of axle	692 mm (2 ft 3 in)	692 mm (2 ft 3 in)	
5	Ground clearance	436 mm (1 ft 5 in)	435 mm (1 ft 5 in)	
6	Overall length	7147 mm (23 ft 5 in)	7649 mm (25 ft 1 in)	
7	Length – rear axle to bumper	1962 mm (6 ft 5 in)	1962 mm (6 ft 5 in)	
8	Center line of front axle to hitch	1400 mm (4 ft 7 in)	1400 mm (4 ft 7 in)	
9	Wheel base length	2800 mm (9 ft 2 in)	2800 mm (9 ft 2 in)	
10	Dump clearance at maximum lift and 45° dump	2828 mm (9 ft 3 in)	3335 mm (10 ft 11 in)	
11	Bucket clearance at maximum lift and level	3556 mm (11 ft 8 in)	4063 mm (13 ft 4 in)	
12	Bucket pin height at maximum lift	3881 mm (12 ft 9 in)	4387 mm (14 ft 5 in)	
13	Overall height – bucket raised	5178 mm (16 ft 12 in)	5684 mm (18 ft 8 in)	
14	Reach at maximum lift and 45° dump	992 mm (3 ft 3 in)	993 mm (3 ft 3 in)	
15	Rack back angle at maximum lift	58°	62°	
16	Dump angle at maximum lift	45°	45°	
17	Rack back angle at ground	50°	50°	
18	Rack back angle at carry	51°	54°	
19	Carry height	435 mm (1 ft 5 in)	592 mm (1 ft 11 in)	
20	Digging depth	64 mm (3 in)	75 mm (3 in)	

Dimensions listed are for 924H with 1.8 m³ (2.4 yd³) hook-on bucket with bolt-on cutting edge, standard cab, optional counterweights, limited slip axles, heavy duty rear brakes, additional guarding, sound suppression, 80 kg (176 lb) operator and Michelin 20.5 R25 L3 XHA tires.

	20.5 R25 L3 XHA Tires		17.5-25 12PR (L-2) Tires	
21	Width at tread center	1880 mm (6 ft 2 in)	1880 mm (6 ft 2 in)	
22	Overall width over tires	2492 mm (8 ft 2 in)	2356 mm (7 ft 9 in)	
23	Minimum turning radius over tires	5104 mm (16 ft 9 in)	5070 mm (16 ft 8 in)	
24	Minimum turning radius over bucket at ground level	5633 mm (18 ft 6 in)	5675 mm (18 ft 7 in)	
25	Steering angle – left/right	40°	40°	
	Change in vertical dimension	no change	no change	–44 mm (–2 in)

924H Wheel Loader Specifications

Dimensions with Pallet Forks

All dimensions are approximate. Dimensions vary with fork length. Refer to Operating Specifications chart below.

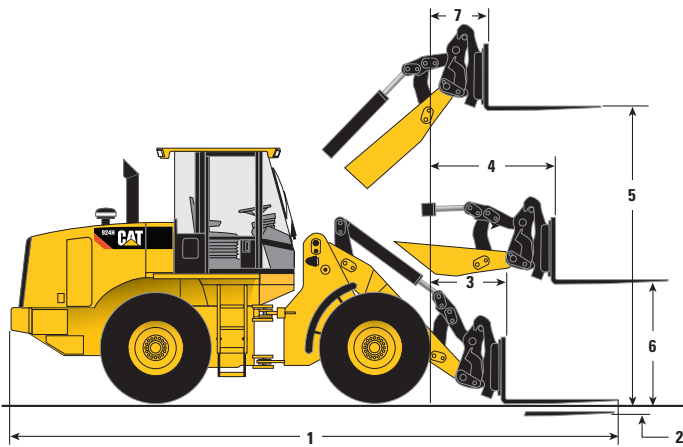

Standard VersaLink

Fork Tine Length

	1220 mm (4 ft 0 in)	1370 mm (4 ft 6 in)	1524 mm (5 ft 0 in)
1	7604 mm (24 ft 11 in)	7769 mm (25 ft 6 in)	7908 mm (26 ft 0 in)
2	-33 mm (-1.3 in)	-33 mm (-1.3 in)	-33 mm (-1.3 in)
3	871 mm (2 ft 10 in)	886 mm (2 ft 11 in)	871 mm (2 ft 10 in)
4	1562 mm (5 ft 1 in)	1577 mm (5 ft 2 in)	1562 mm (5 ft 1 in)
5	3637 mm (11 ft 11 in)	3652 mm (12 ft 0 in)	3637 mm (11 ft 11 in)
6	1790 mm (5 ft 10 in)	1805 mm (5 ft 11 in)	1790 mm (5 ft 10 in)
7	762 mm (2 ft 6 in)	777 mm (2 ft 7 in)	762 mm (2 ft 6 in)

High Lift VersaLink

	1220 mm (4 ft 0 in)	1370 mm (4 ft 6 in)	1524 mm (5 ft 0 in)
1	8113 mm (26 ft 7 in)	8278 mm (27 ft 2 in)	8417 mm (27 ft 8 in)
2	-43 mm (-1.7 in)	-43 mm (-1.7 in)	-43 mm (-1.7 in)
3	1379 mm (4 ft 6 in)	1394 mm (5 ft 0 in)	1379 mm (5 ft 0 in)
4	1953 mm (6 ft 5 in)	1968 mm (6 ft 5 in)	1953 mm (6 ft 5 in)
5	4145 mm (13 ft 7 in)	4160 mm (13 ft 8 in)	4145 mm (13 ft 7 in)
6	1790 mm (5 ft 10 in)	1805 mm (5 ft 11 in)	1790 mm (5 ft 10 in)
7	762 mm (2 ft 6 in)	777 mm (2 ft 7 in)	762 mm (2 ft 6 in)

Operating Specifications with Pallet Forks

Standard VersaLink

Operating load:

Per SAE J1197 FEB91 (50% of FTSTL)

Per EN 474-3, rough terrain (60% of FTSTL)

Per EN 474-3, firm & level ground (80% of FTSTL)

Load center:

Per SAE J1197

Per EN 474-3

Static tipping load with level arms and forks, straight*

Static tipping load with level arms and forks, full 40° turn*

Operating weight*

	Fork Tine Length					
	1220 mm (4 ft 0 in)	1370 mm (4 ft 6 in)	1524 mm (5 ft 0 in)			
Operating load:						
Per SAE J1197 FEB91 (50% of FTSTL)	2724 kg (6,005 lb)	2616 kg (5,767 lb)	2546 kg (5,613 lb)			
Per EN 474-3, rough terrain (60% of FTSTL)	3279 kg (7,229 lb)	3230 kg (7,121 lb)	3225 kg (7,110 lb)			
Per EN 474-3, firm & level ground (80% of FTSTL)	4372 kg (9,639 lb)	4306 kg (9,493 lb)	4300 kg (9,480 lb)			
Load center:						
Per SAE J1197	610 mm (24 in)	685 mm (27 in)	762 mm (30 in)			
Per EN 474-3	600 mm (23.6 in)	600 mm (23.6 in)	600 mm (23.6 in)			
Static tipping load with level arms and forks, straight*	6200 kg (13,669 lb)	5962 kg (13,144 lb)	5808 kg (12,805 lb)			
Static tipping load with level arms and forks, full 40° turn*	5447 kg (12,009 lb)	5231 kg (11,532 lb)	5091 kg (11,224 lb)			
Operating weight*	11 209 kg (24,712 lb)	11 268 kg (24,842 lb)	11 298 kg (24,908 lb)			

High Lift VersaLink

Operating load:

Per SAE J1197 FEB91 (50% of FTSTL)

Per EN 474-3, rough terrain (60% of FTSTL)

Per EN 474-3, firm & level ground (80% of FTSTL)

Load center:

Per SAE J1197

Per EN 474-3

Static tipping load with level arms and forks, straight*

Static tipping load with level arms and forks, full 40° turn*

Operating weight*

	Fork Tine Length					
	1220 mm (4 ft 0 in)	1370 mm (4 ft 6 in)	1524 mm (5 ft 0 in)			
Operating load:						
Per SAE J1197 FEB91 (50% of FTSTL)	2329 kg (5,135 lb)	2241 kg (4,941 lb)	2183 kg (4,813 lb)			
Per EN 474-3, rough terrain (60% of FTSTL)	2803 kg (6,180 lb)	2758 kg (6,080 lb)	2749 kg (6,061 lb)			
Per EN 474-3, firm & level ground (80% of FTSTL)	3738 kg (8,241 lb)	3677 kg (8,106 lb)	3666 kg (8,082 lb)			
Load center:						
Per SAE J1197	610 mm (24 in)	685 mm (27 in)	762 mm (30 in)			
Per EN 474-3	600 mm (23.6 in)	600 mm (23.6 in)	600 mm (23.6 in)			
Static tipping load with level arms and forks, straight*	5322 kg (11,733 lb)	5128 kg (11,305 lb)	5003 kg (11,030 lb)			
Static tipping load with level arms and forks, full 40° turn*	4658 kg (10,269 lb)	4481 kg (9,879 lb)	4367 kg (9,628 lb)			
Operating weight*	11 327 kg (24,972 lb)	11 386 kg (25,102 lb)	11 417 kg (25,170 lb)			

* Static tipping and operating weights shown are for 924H with 1.8 m³ (2.4 yd³) hook-on bucket with bolt-on cutting edge, standard cab, optional counterweights, limited slip axles, heavy duty rear brakes, additional guarding, sound suppression, 80 kg (176 lb) operator and Michelin 20.5 R25 L3 XHA tires. Tipping load is defined by SAEJ732 JUN92.

Standard VersaLink

Operating Specifications with Bucket

		Coupler Buckets			Pin-On Buckets		
		Bolt-On Cutting Edge			Bolt-On Cutting Edge		
Rated bucket capacity (§)	m ³	1.8	2.1	2.8	1.8	2.1	2.8
	yd ³	2.4	2.7	3.7	2.4	2.7	3.7
Struck capacity (§)	m ³	1.5	1.7	2.3	1.5	1.7	2.3
	yd ³	2.0	2.2	3.0	2.0	2.2	3.0
Bucket width	mm	2550	2550	2550	2550	2550	2550
	ft/in	8'4"	8'4"	8'4"	8'4"	8'4"	8'4"
10 Dump clearance at full lift and 45° discharge (§)	mm	2828	2759	2621	2918	2849	2712
	ft/in	9'3"	9'1"	8'7"	9'7"	9'4"	8'11"
14 Reach at full lift and 45° discharge (§)	mm	992	1060	1197	885	957	1093
	ft/in	3'3"	3'6"	3'11"	2'11"	3'2"	3'7"
Reach at 45° discharge and 2130 mm (7'0") clearance (§)	mm	1516	1548	1603	1453	1491	1553
	ft/in	5'0"	5'1"	5'3"	4'9"	4'11"	5'1"
Reach with lift arms horizontal and bucket level	mm	2296	2392	2586	2156	2255	2442
	ft/in	7'6"	7'10"	8'6"	7'1"	7'5"	8'0"
20 Digging depth (§)	mm	64	72	89	64	70	87
	in	2.5"	2.8"	3.5"	2.5"	2.8"	3.4"
6 Overall length	mm	7147	7251	7460	7007	7112	7320
	ft/in	23'5"	23'9"	24'6"	23'0"	23'4"	24'0"
13 Overall height with bucket at full raise (§)	mm	5067	5194	5328	4966	5095	5152
	ft/in	16'7"	17'0"	17'6"	16'4"	16'9"	16'11"
24 Loader clearance radius with bucket in carry position (§)	mm	5568	5597	5658	5530	5558	5616
	ft/in	18'3"	18'4"	18'7"	18'2"	18'3"	18'5"
Static tipping load straight (§)	kg	8310	8126	7871	8738	8557	8272
	lb	18,320	17,916	17,353	19,265	18,866	18,236
Static tipping load full 40° turn (§)	kg	7276	7098	6859	7666	7490	7222
	lb	16,041	15,647	15,122	16,900	16,512	15,923
Breakout force (§)	kg	9857	9003	7706	11 336	10 250	8626
	lb	21,731	19,848	16,989	24,992	22,597	19,017
Operating weight	kg	11 501	11 635	11 744	11 379	11 515	11 638
	lb	25,355	25,651	25,891	25,087	25,386	25,658

Static tipping and operating weights shown are for 924H with cab with A/C, optional counterweight, limited slip axles, heavy duty rear brakes, additional guarding, sound suppression, work tool, 80 kg (176 lb) operator and Michelin 20.5 R25 L3 XHA tires.

(§) Specifications and ratings conform to all applicable standards recommended by the Society of Automotive Engineers (SAE), including SAE-Standards J732 JUN92 and J742 FEB85 governing ratings.

Other Ground Engaging Tools available, consult your Cat dealer.

924H Wheel Loader Specifications

High Lift VersaLink

Operating Specifications with Bucket

		Coupler Buckets			Pin-On Buckets
		Bolt-On Cutting Edge			Bolt-On Cutting Edge
Rated bucket capacity (§)	m ³	1.8	2.1	2.8	2.8
	yd ³	2.4	2.7	3.7	3.7
Struck capacity (§)	m ³	1.5	1.7	2.3	2.3
	yd ³	2.0	2.2	3.0	3.0
Bucket width	mm	2550	2550	2550	2550
	ft/in	8'4"	8'4"	8'4"	8'4"
10 Dump clearance at full lift and 45° discharge (§)	mm	3335	3267	3129	3220
	ft/in	10'11"	10'9"	10'3"	10'7"
14 Reach at full lift and 45° discharge (§)	mm	992	1060	1197	1093
	ft/in	3'3"	3'6"	3'11"	3'7"
Reach at 45° discharge and 2130 mm (7'0") clearance (§)	mm	1947	1985	2054	1995
	ft/in	6'5"	6'6"	6'9"	6'7"
Reach with lift arms horizontal and bucket level	mm	2686	2783	2976	2838
	ft/in	8'10"	9'2"	9'9"	9'4"
20 Digging depth (§)	mm	74	82	99	97
	in	2.9"	3.2"	3.9"	3.8"
6 Overall length	mm	7649	7752	7957	7818
	ft/in	25'1"	25'5"	26'1"	25'8"
13 Overall height with bucket at full raise (§)	mm	5574	5702	5836	5660
	ft/in	18'3"	18'8"	19'2"	18'7"
24 Loader clearance radius with bucket in carry position (§)	mm	5828	5861	5931	5885
	ft/in	19'1"	19'3"	19'6"	19'4"
Static tipping load straight (§)	kg	6789	6621	6410	6718
	lb	14,968	14,596	14,131	14,810
Static tipping load full 40° turn (§)	kg	5916	5751	5552	5833
	lb	13,042	12,679	12,240	12,860
Breakout force (§)	kg	9857	9003	7706	8626
	lb	21,731	19,848	16,989	19,017
Operating weight	kg	11 620	11 754	11 863	11 757
	lb	25,618	25,913	26,154	25,920

Static tipping and operating weights shown are for 924H with cab with A/C, optional counterweight, limited slip axles, heavy duty rear brakes, additional guarding, sound suppression, work tool, 80 kg (176 lb) operator and Michelin 20.5 R25 L3 XHA tires.

(§) Specifications and ratings conform to all applicable standards recommended by the Society of Automotive Engineers (SAE), including SAE-Standards J732 JUN92 and J742 FEB85 governing ratings.

Other Ground Engaging Tools available, consult your Cat dealer.

Supplemental Specifications

	Change in Operating Weight		Change in Articulated Static Tipping Load with Hook-On Bucket 1.8 m ³ (2.4 yd ³)	
	kg	lb	kg	lb
Canopy, ROPS (less cab)	-199	-438	-166	-365
Without optional counterweights (175 kg/385 lb)	-175	-385	-273	-601
Without guard, crankcase	-15	-33	-19	-42
Without guard, driveshaft	-17	-37	-5	-11
Without guard, power train	-52	-114	-47	-103
Without ride control system	-40	-88	-27	-59
Without secondary steering	-37	-81	-31	-68
Tires, 1-piece rims				
17.5-25, 12PR (L-2)	-652	-1,434	-371	-816
17.5-25, 12PR (L-3)	-580	-1,276	-330	-726
17.5-25, radial (L-2)	-612	-1,346	-348	-766
17.5-25, radial (L-3)	-512	-1,126	-292	-642
Tires, 3-piece rims				
17.5-25, 12PR (L-2)	-528	-1,162	-301	-662
17.5-25, 12PR (L-3)	-456	-1,003	-260	-572
17.5-25, radial (L-2)	-488	-1,074	-278	-612
17.5-25, radial (L-3)	-388	-854	-221	-486
550/65 R25, radial (L-2)	-196	-431	-112	-246
550/65 R25, radial (L-3)	-136	-299	-78	-172
20.5-25, 12PR (L-2)	-240	-528	-134	-295
20.5-25, 12PR (L-3)	-36	-79	-21	-46
20.5-25, radial (L-2)	-172	-378	-98	-216
20.5-25, radial (L-3)	0	0	0	0

924H Wheel Loader Specifications

Typical Material Densities – Loose

	kg/m ³	lb/yd ³		kg/m ³	lb/yd ³
Basalt	1960	3,305	Gypsum		
Bauxite, Kaolin	1420	2,394	broken	1810	3,052
Clay			crushed	1600	2,698
natural bed	1660	2,799	Limestone		
dry	1480	2,495	broken	1540	2,596
wet	1660	2,799	crushed	1540	2,596
Clay and gravel			Sand		
dry	1420	2,394	dry, loose	1420	2,394
wet	1540	2,596	damp	1690	2,849
Decomposed rock			wet	1840	3,102
75% rock, 25% earth	1960	3,305	Sand and clay		
50% rock, 50% earth	1720	2,900	loose	1600	2,698
25% rock, 75% earth	1570	2,647	Sand and gravel		
Earth			dry	1720	2,900
dry, packed	1510	2,546	wet	2020	3,416
wet, excavated	1600	2,698	Sandstone	1510	2,546
Granite			Shale	1250	2,107
broken	1660	2,799	Slag		
Gravel			broken	1750	2,950
pitrun	1930	3,254	Stone		
dry	1510	2,546	crushed	1600	2,698
dry, 6-50 mm (0.2-2")	1690	2,849	Wood chips	400	680
wet, 6-50 mm (0.2-2")	2020	3,406			

Bucket Selection – Coupler Buckets

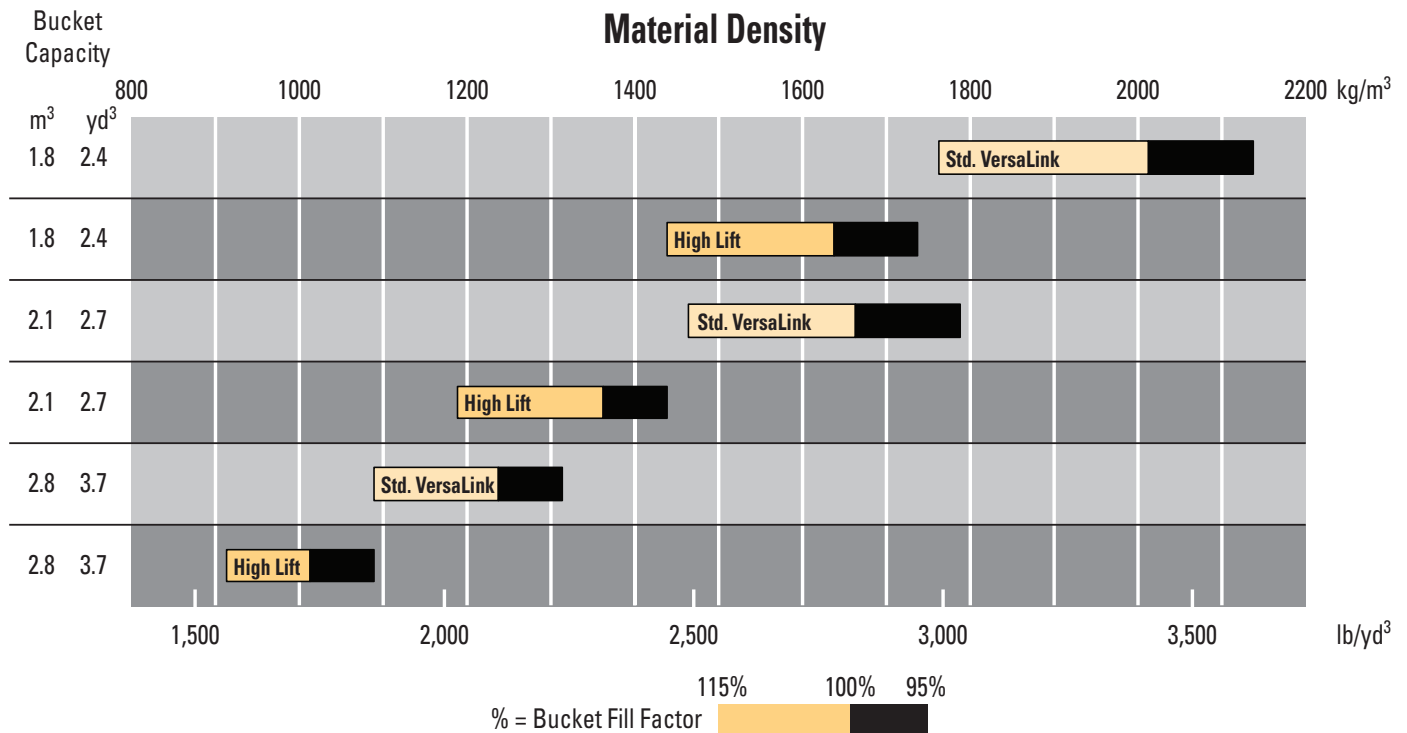

Standard equipment may vary. Consult your Caterpillar dealer for details.

ELECTRICAL

Alternator, 95-amp brushless
Alarm, back-up
Batteries, maintenance-free, 950 CCA, (2)
Directional signals (front & rear)
Starting and charging system, 24V
Halogen work lights (front & rear)
Ignition key start/stop switch
Roading lights
Starting aid, thermal
Switch, battery disconnect

OPERATOR ENVIRONMENT

Standard two door cab includes all of the following items:
Air conditioner, heater/defroster
Sliding glass door windows
Radio ready
12 volt electrical accessory outlet
Sealed Instrument Gauge:
• Engine RPM
• Hydraulic oil temperature
• Engine coolant temperature
• Torque converter oil temperature
• Fuel level
• Digital LED speedometer, hour meter/odometer
Indicator Lights:
• Turn signal
• Primary steering malfunction
• Hydraulic oil bypass
• Parking brake applied
• Brake charge pressure low
• Transmission oil temperature
• General warning
• Electrical system voltage low
• Fuel water separator
• Engine oil temperature
• Bright lights activated
Adjustable tilt steering column
Coat hook
Ground level door release

Horn, steering wheel mounted (electric)
Hydraulic control lever lockout
Interior light
Lighter
Lunch box storage with cup holder
Pilot hydraulic implement controls
Rear window defroster, electric
Rear view mirrors (2 inside)
Seat, adjustable suspension, armrest (fabric or vinyl)
Seat belt, 75 mm (3 in), retractable
Tinted safety glass, front
Tool box
Wet arm wiper/washer (front & rear), front intermittent

POWER TRAIN

Engine, Cat C6.6 ACERT
• Low emission diesel engine
• Noise reduction technology
• Smart waste gate turbocharged
• Aftercooled
• Closed Circuit Breather
• Electronically controlled
Air cleaner, dry type
Axle seal guards, integrated
Brakes, enclosed wet-disc full hydraulic
Differentials, conventional (front/rear)
Driveshaft, lubed for life
Electric fuel prime pump
Engine speed control
Fuel/water separator
Muffler
Radiator, unit serviceable
S•O•S oil sampling port, engine oil
S•O•S oil sampling port, transmission oil
Torque converter
Transmission, 4F/3R, autoshift, single lever control with F/N/R and kickdown button
Transmission neutralizer; operator programmable

HYDRAULICS

Hydraulic diagnostic connectors
Heavy duty hydraulic oil cooler
Hydraulic control, 3-valve, 2-lever with F/N/R
Hydraulics, third function
Load-sensing hydraulic system
Load-sensing steering system
S•O•SSM oil sampling port, hydraulic oil

OTHER STANDARD EQUIPMENT

Antifreeze/coolant, extended-life protects to -36° C (-33° F)
Automatic bucket positioner/fork positioner
Brakes, secondary and parking
Counterweight
Coupler controls and lines
Engine enclosure, lockable
Fenders, front
Hitch, recovery
Loader linkage, VersaLink
Lift kickout, automatic
Machine Security System ready
Product Link ready
Remote grease lines
Steering stops, cushioned
Swing-out, hydraulically driven demand fan
Vandalism protection, lockable service points
Visual indicators:
• air cleaner service
• coolant level
• hydraulic oil
• transmission oil

924H Optional Equipment

Optional equipment may vary. Consult your Caterpillar dealer for details.

Antifreeze/coolant, extended-life, protects to
-50° C (-58° F)

Axles:

- Front, Limited Slip Differential
- Rear, Limited Slip Differential
- Rear, Limited Slip Differential with heavy duty brakes (axle oil cooler included)

Beacon light, rotating or strobe,
magnetic-mount

Buckets/ground engaging tools

Canopy, ROPS

Counterweight, additional, optional

Deluxe Cab arrangement includes:

- External heated mirrors
- Sunscreen
- Sun shade
- Flood lights, auxiliary, cab mounted

Fan, reversing

Fenders, roading, rear

Fenders, steel

Guards:

- Crankcase
- Driveshaft, front
- Power train
- Lights
- Windshield
- Radiator

Hydraulic control auxiliary; third, fourth,
fifth and sixth valve

Integrated third function hydraulic joystick
control

Linkage, high lift

Load check valves (dealer installed)

Low speed transmission

Machine Security System

Material handling arm

Pallet forks, carriage

Pallet forks, carriage, wide version

Product Link

Quick Coupler, IT style

Radiator, wide fin spacing, 5.5 fpi

Radio packages:

- Radio, AM/FM
- Radio, AM/FM with CD player

Rear-view camera system

Ride Control System

Seats:

- Cat Contour Seat, fabric, with adjustable backrest and lumbar support
- Cat Contour Seat, fabric, electrically adjustable with air suspension

Sound suppression package, available in
select markets

Starting aid, engine coolant heater, 120V

Steering, secondary

Tires:

- Bias ply, 17.5-25 and 20.5-25
- Radial, 17.5-R25, 20.5-R25 and 550/65 R25

924H Wheel Loader

For more complete information on Cat products, dealer services, and industry solutions, visit us on the web at www.cat.com

© 2007 Caterpillar Inc.
All rights reserved
Printed in the U.S.A.

Materials and specifications are subject to change without notice. Featured machines may include additional equipment. See your Caterpillar dealer for available options.

CAT, CATERPILLAR, their respective logos, "Caterpillar Yellow" and the POWER EDGE trade dress, as well as corporate and product identity used herein, are trademarks of Caterpillar and may not be used without permission.

AEHQ5906 (08-2007)
Replaces AEHQ0545-04

CATERPILLAR[®]