



C15 ACERT™
Industrial Engine
Tier 3/Stage IIIA
403 bkW/540 bhp @ 2100 rpm

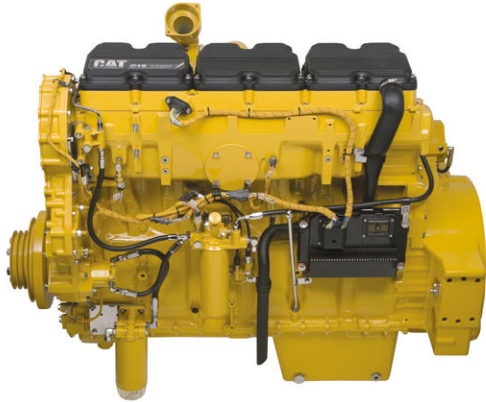

Image shown may not reflect actual engine

CAT® ENGINE SPECIFICATIONS

I-6, 4-Stroke-Cycle Diesel

Bore.....	137.2 mm (5.4 in)
Stroke.....	171.4 mm (6.75 in)
Displacement.....	15.2 L (927.56 in ³)
Aspiration.....	Turbocharged Aftercooled
Compression Ratio.....	18.0:1
Rotation (from flywheel end).....	Counterclockwise
Weight, Net Dry (approximate kg. lb)..	1469 kg (3239 lb)

FEATURES

Emissions

Meets U.S. EPA Tier 3, EU Stage IIIA emission requirements.

Worldwide Supplier Capability

Caterpillar
- Casts engine blocks, heads, cylinder liners, and flywheel housings
- Machines critical components
- Assembles complete engine
- Factory-designed systems built at Caterpillar ISO 9001:2000 certified facilities
Ownership of these manufacturing processes enables Caterpillar to produce high quality, dependable product.

Testing

Prototype testing on every model:
- proves computer design
- verifies system torsional stability
- functionality tests every model

Every Caterpillar engine is dynamometer tested under full load to ensure proper engine performance.

Full Range of Attachments

Wide range of bolt-on system expansion attachments, factory designed and tested.

Unmatched Product Support Offered Through Worldwide Caterpillar Dealer Network

More than 1,800 dealer outlets
Caterpillar factory-trained dealer technicians service every aspect of your industrial engine
99.7% of parts orders filled within 24 hours worldwide
Caterpillar parts and labor warranty
Preventive maintenance agreements available for repair before failure options

Scheduled Oil Sampling program matches your oil sample against Caterpillar set standards to determine:

- internal engine component condition
- presence of unwanted fluids
- presence of combustion by-products

Web Site

For all your industrial power requirements, visit www.cat-industrial.com.



C15 ACERT™ Industrial Engine

Tier 3/Stage IIIA

403 bkW/540 bhp @ 2100 rpm

STANDARD ENGINE EQUIPMENT

Air Inlet System

ATAAC
Turbocharged

Control System

Electronic governing
PTO speed control
Programmable ratings
Cold mode start strategy
Automatic altitude compensation
Power compensation for fuel temperature
Programmable low and high idle and total engine limit
Electronic diagnostics and fault logging
Engine monitoring system
J1939 Broadcast (diagnostic and engine status)
ADEM™ A4

Cooling System

Thermostats and housing, vertical outlet
Jacket water pump, centrifugal
Water pump, inlet

Exhaust System

Exhaust manifold, dry
Optional exhaust outlet

Flywheels and Flywheel Housing

SAE No. 1 Flywheel housing

Fuel System

MEUI injection
Fuel filter, secondary (2 micron high performance)
Fuel transfer pump
Fuel priming pump
ACERT™ Technology

Lube System

Crankcase breather
Oil cooler
Oil filler
Oil filter
Oil pan front sump
Oil dipstick
Oil pump (gear driven)

General

Paint, Caterpillar Yellow
Vibration damper
Lifting eyes



**C15 ACERT™
Industrial Engine**

Tier 3/Stage IIIA

403 bkW/540 bhp @ 2100 rpm

PERFORMANCE CURVES

IND - C (Intermittent) - DM7520-01

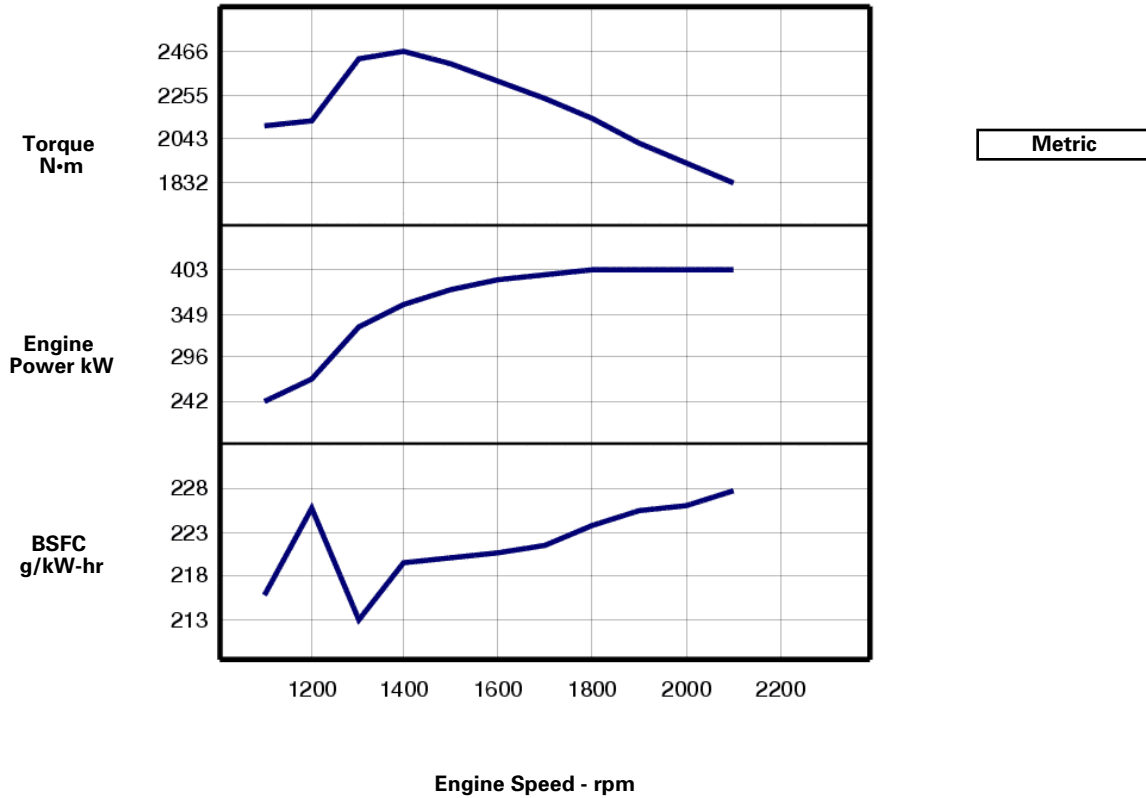

Engine Speed rpm	Engine Power kW	Torque N·m	BSFC g/kW-hr	Fuel Rate L/hr
2100	403	1832	227.7	109.4
2000	403	1924	225.9	108.5
1900	403	2025	225.5	108.3
1800	403	2138	223.7	107.4
1700	398	2236	221.4	105.1
1600	390	2325	220.6	102.4
1500	378	2404	220.1	99.1
1400	362	2466	219.6	94.6
1300	331	2434	212.8	84.1
1200	268	2134	225.6	72.1
1100	242	2102	215.9	62.3



**C15 ACERT™
Industrial Engine**

Tier 3/Stage IIIA

403 bkW/540 bhp @ 2100 rpm

PERFORMANCE CURVES

IND - C (Intermittent) - DM7520-01

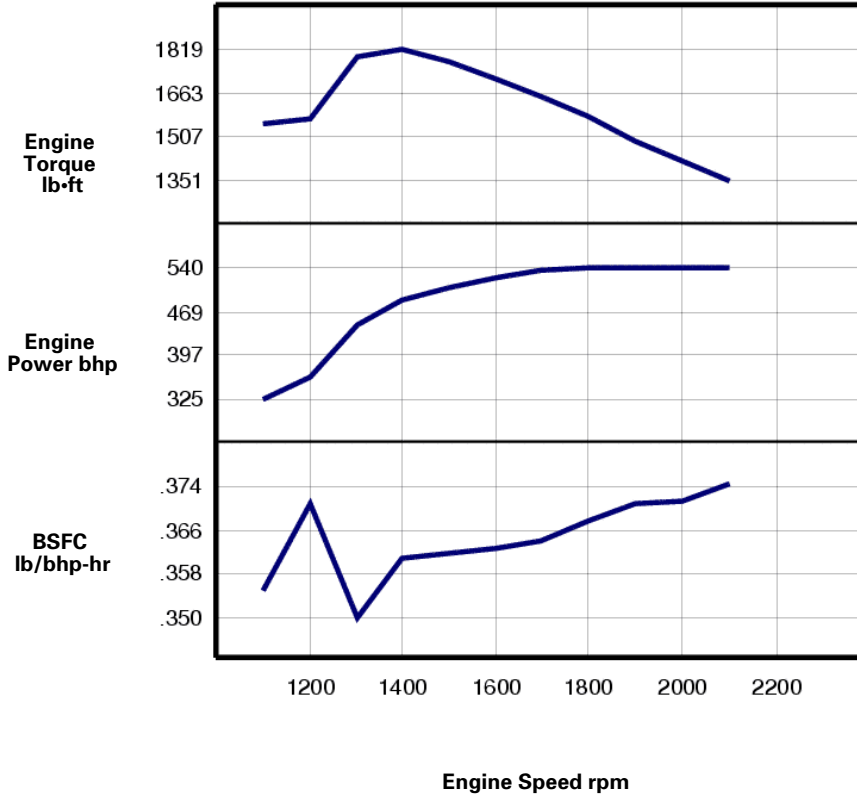

Engine Speed rpm	Engine Power bhp	Engine Torque lb-ft	BSFC lb/bhp-hr	Fuel Rate gal/hr
2100	540	1351	.374	28.9
2000	540	1419	.371	28.7
1900	540	1494	.371	28.6
1800	540	1577	.368	28.4
1700	534	1649	.364	27.8
1600	522	1715	.363	27.1
1500	506	1773	.362	26.2
1400	485	1819	.361	25.0
1300	444	1795	.350	22.2
1200	360	1574	.371	19.0
1100	325	1550	.355	16.5



C15 ACERT™ Industrial Engine

Tier 3/Stage IIIA

403 bkW/540 bhp @ 2100 rpm

RATINGS AND CONDITIONS

IND - C (Intermittent) Intermittent service where maximum power and/or speed are cyclic (time at full load not to exceed 50%).

Engine Performance Diesel Engines — 7 liter and higher
All rating conditions are based on SAE J1995, inlet air standard conditions of 99 kPa (29.31 in. Hg) dry barometer and 25°C (77°F) temperature. Performance measured using a standard fuel with fuel gravity of 35° API having a lower heating value of 42,780 kJ/kg (18,390 btu/lb) when used at 29° C (84.2° F) with a density of 838.9 g/L.

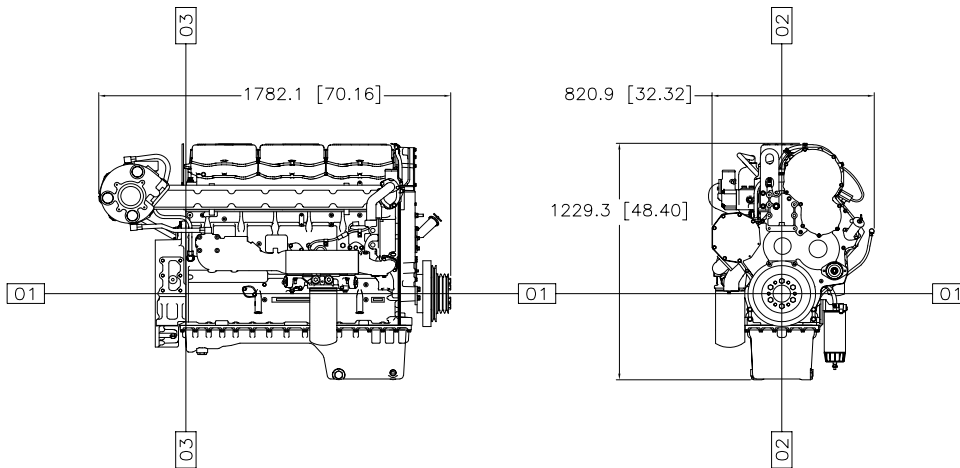

Engine Dimensions

(1) Length	1380.9 mm (54.37 in)
(2) Width	926.4 mm (36.47 in)
(3) Height	1248.3 mm (49.15 in)

Note: Do not use for installation design. See general dimension drawings for detail (Drawing # 2579952).

Performance Number: DM7520-01

Feature Code: C15D112 Arr. Number: 2543835

Materials and specifications are subject to change without notice.

16286403

© 2012 Caterpillar

All rights reserved.

The International System of Units (SI) is used in this publication.

CAT, CATERPILLAR, their respective logos, "Caterpillar Yellow," the "Power Edge" trade dress, as well as corporate and product identity used herein, are trademarks of Caterpillar and may not be used without permission.