

2500 Series 2506D-E15TA Industrial Engine

EU Stage IIIA, U.S. EPA Tier 3
328-444 kW / 440-595 hp

The ability to power your machine line-up with one engine supplier is truly achievable with Perkins. We have introduced a platform of 9-18 litre industrial engines that completes our market-leading industrial power range and covers 8.8-597 kW (11.8-800 hp).

This model is a turbocharged, air-to-air chargecooled, 15.2 litre, 6 cylinder product capable of producing 444 kW (595 hp).

The exceptional power density and reliability of these engines make them an ideal choice for applications operating in countries that meet equivalent Stage IIIA/ Tier 3 and China III emissions standards.

To support the demands of your machine installation we offer a choice of engine configurations and options. The robust technology allows you to integrate these engines into your equipment with the minimum of re-engineering.

Perkins has developed a reputation for designing and building reliable and durable engines for the most demanding applications. Choosing Perkins as your engine supplier means your development costs can be reduced and your machines are future-proofed to meet anticipated emissions standards.

Designed to meet EU Stage IIIA and U.S. EPA Tier 3 equivalent emissions standards.

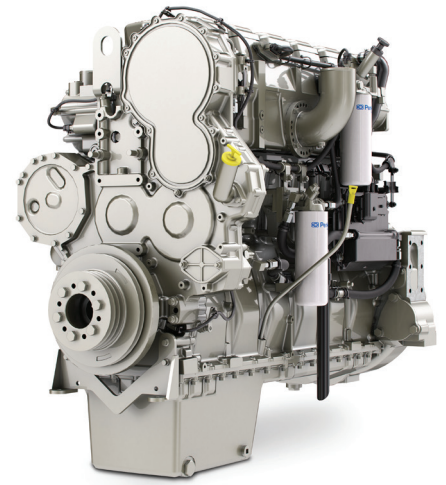

Specification		
Number of cylinders	6 vertical in-line	
Bore and stroke	137 x 171 mm	5.4 x 6.7 in
Displacement	15.2 litres	928 cubic in
Aspiration	Turbocharged aftercooled	
Cycle	4 stroke	
Combustion system	Direct injection	
Compression ratio	18.0:1	
Rotation	Anti-clockwise, viewed on flywheel	
Total lubricating capacity	38-64 litres	10-16.9 US gal
Cooling system	Liquid	

www.perkins.com

Photographs are for illustrative purposes only and may not reflect final specification.
All information in this document is substantially correct at time of printing and may be altered subsequently.
Final weight and dimensions will depend on completed specification.

Publication No. PN3118/04/16 Produced in England ©2016 Perkins Engines Company Limited

 **Perkins**[®]

THE HEART OF EVERY GREAT MACHINE

2500 Series 2506D-E15TA Industrial Engine

EU Stage IIIA, U.S. EPA Tier 3
328-444 kW / 440-595 hp

Features and benefits

Dependable power

- World-class manufacturing capability and processes coupled with proven core engine designs assure reliability, quiet operation and many hours of productive life

High performance

- Simple and efficient turbocharger provides optimal air management and improved fuel efficiency

Lifetime of low cost

- Fuel consumption optimised to match operating cycles of a wide range of equipment and applications.
- Capability of 500 hour oil change intervals enables low-cost maintenance

Fuel and oil

- Approved for operation on biodiesel* concentrations of up to 20%*

Package size

- Exceptional power density enables standardisation across numerous applications. Multiple installation options available to minimize total package size

Local support, global coverage

- Perkins recognise that the customer relationship is important to machine manufacturers and we can offer a range of flexible solutions to help provide appropriate support, either to the OEM's network or directly to the machine customer
- With highly trained Perkins distributors in thousands of communities in over 180 countries, you are never far away from expert product knowledge, genuine parts and a range of advanced diagnostic technology for keeping your engine in peak condition
- To find your local distributor: www.perkins.com/distributor

*Subject to conformance with ASTM D6751 and EN14214

www.perkins.com

Photographs are for illustrative purposes only and may not reflect final specification.
All information in this document is substantially correct at time of printing and may be altered subsequently.
Final weight and dimensions will depend on completed specification.

Publication No. PN3118/04/16 Produced in England ©2016 Perkins Engines Company Limited

 **Perkins**[®]

THE HEART OF EVERY GREAT MACHINE

2500 Series 2506D-E15TA Industrial Engine

EU Stage IIIA, U.S. EPA Tier 3
328-444 kW / 440-595 hp

Technical information

Air inlet

- Turbocharged aftercooled

Control system

- Full electronic control system
- All connectors and wiring looms waterproof and designed to withstand harsh off-highway environments
- Flexible and configurable software features and well supported SAE J1939 CAN bus enables highly integrated machines

Cooling system

- Vertical outlet thermostat housing, centrifugal water pump
- Detailed guidance on cooling system design and validation available to ensure machine reliability

Flywheel and housing

- Wide choice of drivetrain interfaces, SAE0 and SAE1 configurations

Fuel and fuel system

- Mechanical Unit Injector Fuel system, controlled electronically

Oil system

- Choice of sumps for different applications
- Open crankcase ventilation system with fumes disposal (optional OCV filter system)
- Oil cooler, oil filler, oil filter, oil dipstick, oil pump (gear-driven)

Power take-off

- SAE1 power take-off available with optional SAE A, SAE B and SAE C power take-off drives
- Engine power can also be taken from the front of the engine on some applications

www.perkins.com

Photographs are for illustrative purposes only and may not reflect final specification.
All information in this document is substantially correct at time of printing and may be altered subsequently.
Final weight and dimensions will depend on completed specification.

Publication No. PN3118/04/16 Produced in England ©2016 Perkins Engines Company Limited

 **Perkins**[®]

THE HEART OF EVERY GREAT MACHINE

2500 Series 2506D-E15TA Industrial Engine

EU Stage IIIA, U.S. EPA Tier 3
328-444 kW / 440-595 hp

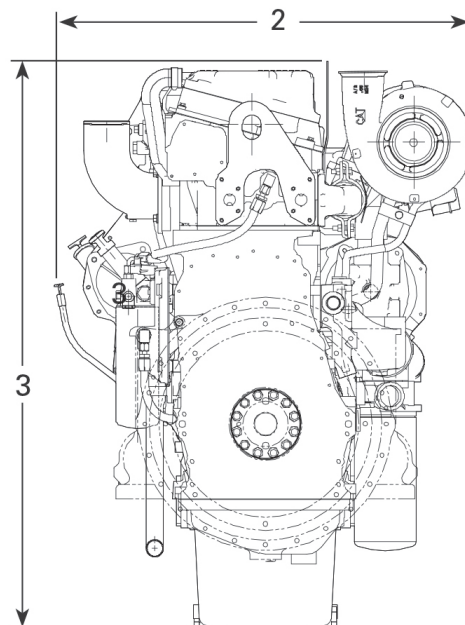
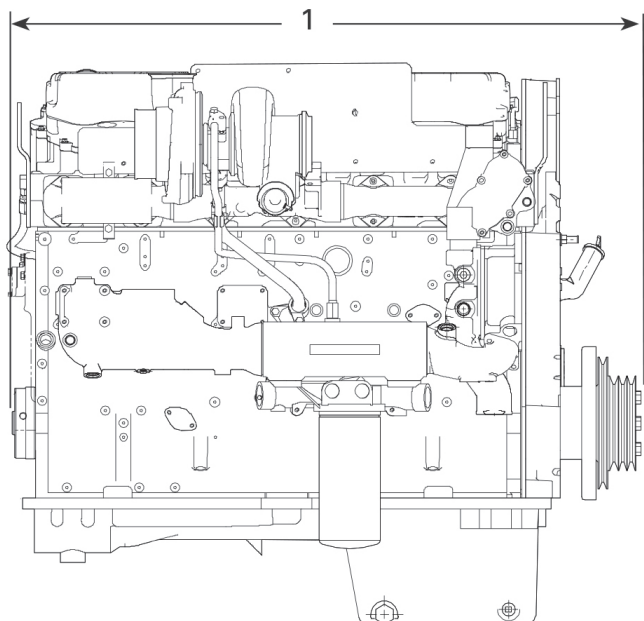

Engine dimensions and weight

1	Length	1377 mm	54.2 in
2	Width	926 mm	36.5 in
3	Height	1226 mm	48.3 in
	Weight	1469 kg	3239 lb

www.perkins.com

Photographs are for illustrative purposes only and may not reflect final specification.
All information in this document is substantially correct at time of printing and may be altered subsequently.
Final weight and dimensions will depend on completed specification.

Publication No. PN3118/04/16 Produced in England ©2016 Perkins Engines Company Limited

 **Perkins**[®]

THE HEART OF EVERY GREAT MACHINE

2500 Series 2506D-E15TA Industrial Engine

EU Stage IIIA, U.S. EPA Tier 3
328-444 kW / 440-595 hp

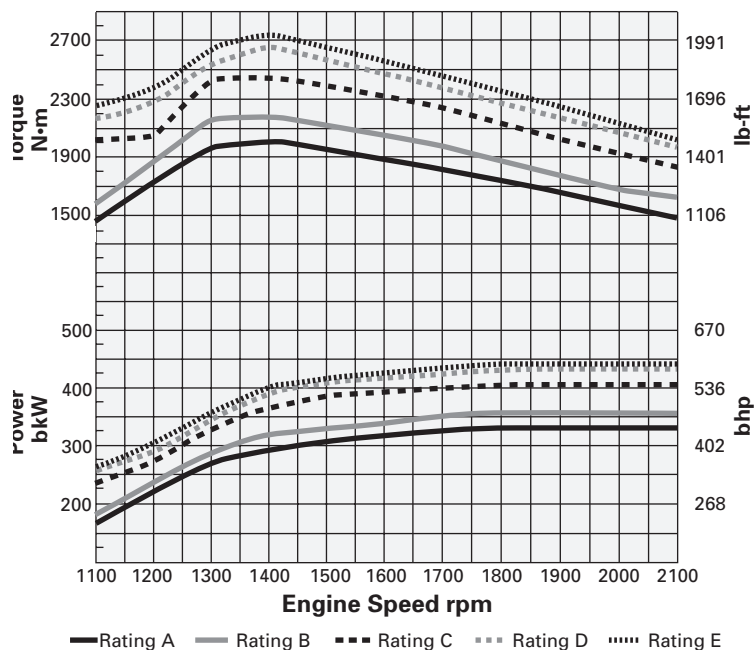

Speed rpm	Power kW	Power hp	Speed rpm	Torque Nm	Torque lb-ft	Rating type
2100	328	440	1400	2012	1484	A
2100	354	475	1400	2169	1600	B
2100	403	540	1400	2466	1819	C
2100	433	580	1400	2648	1953	D
2100	444	595	1400	2717	2004	E

Rating definitions and conditions

IND-A (Continuous) for heavy duty service where the engine is operated at maximum power and speed up to 100% of the time without interruption or load cycling.

IND-B for service where power and/or speed are cyclic (time at full load not to exceed 80%).

IND-C (Intermittent) is the horsepower and speed capability of the engine where maximum power and/or speed are cyclic (time at full load not to exceed 50%).

IND-D for service where maximum power is required for periodic overloads (time at full load not to exceed 10% of the duty cycle).

IND-E for service where maximum power is required for a short time for initial starting or sudden overload. For emergency service where standard power is unavailable (time at full load not to exceed 5% of the duty cycle).

Rating Conditions for Diesel Engines – 7 litre and higher

All rating conditions are based on SAE J1995, inlet air standard conditions of 99 kPa (29.31 in. Hg) dry barometer and 25°C (77°F) temperature. Performance is measured using a standard fuel with fuel gravity of 35° API having a lower heating value of 42,780 kJ/kg (18,390 btu/lb) when used at 29°C (84.2°F) with a density of 838.9 g/L.

www.perkins.com

Photographs are for illustrative purposes only and may not reflect final specification. All information in this document is substantially correct at time of printing and may be altered subsequently. Final weight and dimensions will depend on completed specification.

Publication No. PN3118/04/16 Produced in England ©2016 Perkins Engines Company Limited



THE HEART OF EVERY GREAT MACHINE