

ON-HIGHWAY BODY BUILDER MANUAL

THE CAT® CT660 VOCATIONAL TRUCK





HEAVY DUTY, REDEFINED

YOU WORK HARD EVERY DAY—and you count on rugged, reliable products to keep your operation up and running. For nearly a century, Caterpillar has helped customers like you get the job done, with equipment that meets the demands of the world's toughest industries. And now we're introducing the only vocational truck worthy of the Cat® name: the CT660.

The first in a full line of vocational trucks built for a wide array of applications, the Class 8 CT660 redefines heavy-duty—while delivering all the power, performance and productivity you expect from Caterpillar. Plus,

it's backed by the unmatched support of the North American Cat Dealer Network, with more than 400 service locations and 2,300 service bays across the United States and Canada.

Loaded with features and options for the toughest jobs, the CT660 is your next dump truck, concrete mixer, waste carrier or all-around heavy hauler—and it's here to work for you.

TABLE OF CONTENTS

PREFACE

CT660 116BBC 6x4 SPECIFICATIONS

| | |
|--|---|
| Weight/Dimensions/Turning Radius | 1 |
| Standard Features | 3 |
| Diagrams | 4 |

CT660 116BBC 8x6 SPECIFICATIONS

| | |
|--|----|
| Weight/Dimensions/Turning Radius | 8 |
| Standard Features | 10 |
| Diagrams | 11 |

CT660 122BBC 6x4 SPECIFICATIONS

| | |
|--|----|
| Weight/Dimensions/Turning Radius | 15 |
| Standard Features | 18 |
| Diagrams | 19 |

CT660 122BBC 8x6 SPECIFICATIONS

| | |
|--|----|
| Weight/Dimensions/Turning Radius | 23 |
| Standard Features | 26 |
| Diagrams | 27 |

CT660 122BBC 4x4 SPECIFICATIONS

| | |
|--|----|
| Weight/Dimensions/Turning Radius | 31 |
| Standard Features | 33 |
| Diagrams | 34 |

CT660 122BBC 6x6 SPECIFICATIONS

| | |
|--|----|
| Weight/Dimensions/Turning Radius | 38 |
| Standard Features | 40 |
| Diagrams | 41 |

ALL MODEL SPECIFICATIONS

| | |
|----------------------|----|
| Diagrams FRONT | 45 |
| Diagrams REAR | 51 |

| | |
|--|-----|
| Diagrams HOOD TILT Side View | 58 |
| CT15 Diagrams HOOD TILT Side View | 61 |
| Diagrams Side View | 62 |
| Diagrams 3/4 Side View | 64 |
| Diagrams PLAN View | 68 |
| CT11/13 Chassis Packaging Diagrams | 72 |
| CT15 Chassis Packaging Diagrams | 112 |

FRAMES

| | |
|---|-----|
| General Frame Recommendations | 119 |
| Identification of Frame Rail Material | 121 |
| Frame Damage | 122 |
| Welding and Reinforcement | 123 |
| Corrosion | 125 |
| Frame Alignment | 126 |
| Repair and Reinforcement Recommended Procedures | 128 |
| Bolt and Torque Information | 138 |
| Special Service Tools | 147 |
| Aftermarket Modifications | 150 |
| Frame Drilling Restrictions | 152 |
| Wheelbase Alterations | 154 |
| Maximum Wheelbase Available | 155 |
| Frame Rail Specifications/Cross-Sections | 156 |
| Frame Rail Reinforcement | 157 |
| Intermediate/AF Crossmembers | 158 |
| Rear Crossmembers | 159 |
| Crossmember Locations | 160 |
| Frame Drilling Guidelines | 185 |
| Recovery Devices | 186 |

FRONT AXLES

| | |
|------------------------|-----|
| Front Axle Tread | 187 |
|------------------------|-----|

FRONT SUSPENSIONS

| | |
|-------------------------------------|-----|
| Front Spring Bracket Location | 189 |
| Frame Height Chart | 190 |

REAR AXLES & REAR SUSPENSIONS

| | |
|------------------------------|-----|
| Rear Axle Tread | 191 |
| Rear Bump Height Chart | 193 |

ELECTRICAL

| | |
|-----------------------------|-----|
| Battery Box Locations | 194 |
| Air Tank Locations | 199 |

BRAKES

| | |
|---|-----|
| Air Brake Modifications | 201 |
| Brake Restrictions | 202 |
| Anti-Lock Air Brake System Schematic | 203 |
| Routing Guidelines | 204 |
| Air-Operated Auxiliary Attachments | 205 |
| Tube Fitting Installation Instructions | 206 |
| Removal and Insertion Procedures for Tubing in QC or PTC Fittings | 207 |
| Air Brake Tubing | 208 |
| Inside Cab & Foot Valve Plumbing | 210 |
| CT11/13 Air Dryer Locations | 212 |
| CT15 Air Dryer Locations | 214 |

STEERING

| | |
|---|-----|
| Steering Gear Location/Dimensions | 215 |
|---|-----|

EXHAUST

| | |
|---|-----|
| Guidelines for Aftertreatment Modifications | 218 |
| Tailpipe, Clearance Charts | 219 |
| Allowable Backpressure Tailpipe Modification Worksheets | 221 |
| CT11/13 Aftertreatment Diagrams | 223 |
| CT15 Aftertreatment Diagrams | 229 |

FIFTH WHEEL

| | |
|--|-----|
| Fifth Wheel Height Calculations | 233 |
| Fifth Wheel Mounting Information | 234 |

ENGINE

| | |
|------------------------------------|-----|
| Engine Location | 247 |
| CT11/13 Engine Port Location | 248 |
| CT15 Engine Port Location | 249 |
| Torque/Power Curves | 250 |
| Torque/Power Curves - SCR | 259 |

TRANSMISSION

| | |
|---------------------------------------|-----|
| PTO Location | 261 |
| Transfer Case Mounting Location | 269 |

CX31 TRANSMISSION

| | |
|---|-----|
| PTO Power Capability | 272 |
| Power Train Oil System | 273 |
| Transmission Gear Selector | 277 |
| Power Take-Off (PTO) Options | 278 |
| Rear PTO Installation Requirements | 281 |
| Application and Instruction for Driveline PTO | 283 |
| Wiring and Connections | 297 |
| Sealing Plugs | 301 |
| Circuits | 302 |
| Additional CX31 Features | 303 |
| Harness | 310 |

FUEL TANKS

| | |
|--------------------------|-----|
| Fuel Tank Location | 317 |
|--------------------------|-----|

CAB

| | |
|---|-----|
| Air Conditioning System Modifications | 324 |
| Cab Dimensions | 325 |
| Door Swing Clearance | 327 |
| Rear Cab Suspension | 328 |
| Dash Switches | 329 |

GOVERNMENT REQUIREMENTS

| | |
|--------------------------------------|-----|
| Your Obligations Under The Law | 332 |
|--------------------------------------|-----|

CT660 116BBC 6x4 SPECIFICATIONS

WEIGHT/DIMENSIONS/TURNING RADIUS (EGR ONLY)

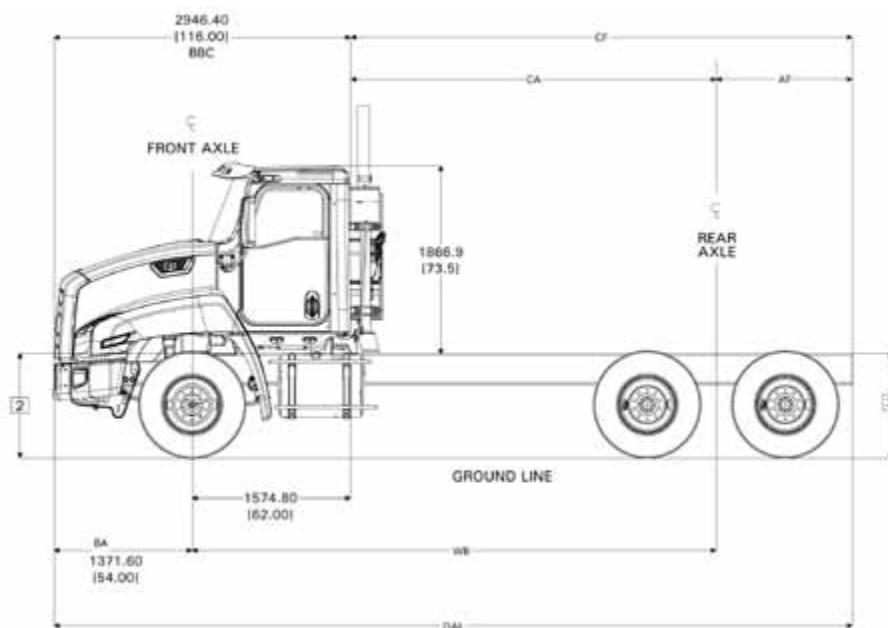

| WHEELBASE (IN.) | CHASSIS WEIGHT (LBS) ** | | | DIMENSIONS (IN.) | | | | TURNING RADIUS | |
|-----------------|-------------------------|-------|--------|------------------|-------|----|-------|----------------|---------------------|
| | FRONT | REAR | TOTAL | CA | CF | AF | OAL | TO CURB | W/ BUMPER CLEARANCE |
| 167 | | | | 104.8 | 157.8 | 53 | 273.8 | 28 ft. 8 in. | 30 ft. 0 in. |
| 181 | | | | 119.1 | 172.2 | 53 | 288.2 | 30 ft. 8 in. | 32 ft. 1 in. |
| 199 | 9,436 | 6,916 | 16,352 | 136.8 | 190 | 53 | 306 | 33 ft. 5 in. | 34 ft. 10 in. |
| 211 | | | | 148.6 | 201.8 | 53 | 317.8 | 35 ft. 2 in. | 36 ft. 8 in. |

** Weight includes standard chassis, standard tires, oil and water, but less fuel.

NOTE: This drawing should not be used to determine crossmember location – this information can be found later in the book.

[↶ return to table of contents](#)

CT660 SCR 116BBC 6x4 SPECIFICATIONS

WEIGHT/DIMENSIONS/TURNING RADIUS (SCR ONLY)

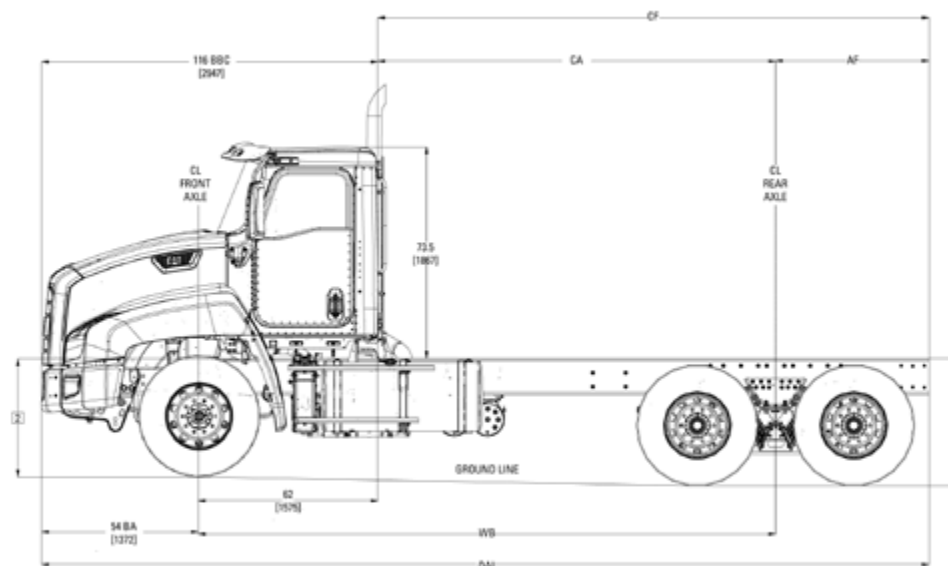

| WHEELBASE (IN.) | CHASSIS WEIGHT (LBS) ** | | | DIMENSIONS (IN.) | | | | TURNING RADIUS | |
|-----------------|-------------------------|-------|--------|------------------|-------|----|-------|----------------|---------------------|
| | FRONT | REAR | TOTAL | CA | CF | AF | OAL | TO CURB | W/ BUMPER CLEARANCE |
| 167 | | | | 104.8 | 157.8 | 53 | 273.8 | 28 ft. 8 in. | 30 ft. 0 in. |
| 181 | | | | 119.1 | 172.2 | 53 | 288.2 | 30 ft. 8 in. | 32 ft. 1 in. |
| 199 | 9,545 | 6,674 | 16,218 | 136.8 | 190 | 53 | 306 | 33 ft. 5 in. | 34 ft. 10 in. |
| 211 | | | | 148.6 | 201.8 | 53 | 317.8 | 35 ft. 2 in. | 36 ft. 8 in. |

** Weight includes standard chassis, standard tires, oil and water, but less fuel.

NOTE: This drawing should not be used to determine crossmember location – this information can be found later in the book.

[↶ return to table of contents](#)

CT660 116BBC 6x4 SPECIFICATIONS

STANDARD FEATURES

| FEATURE | SPECIFICATION |
|--------------------------------|---|
| FRAME RAILS | FRAME RAILS Heat Treated Alloy Steel (120,000 PSI Yield); 12.250" x 3.380" x 0.375" (304.8mm x 85.6mm x 9.5mm); 543.0" (13793mm) Maximum Frame Length |
| FRONT NON-DRIVING AXLE | Meritor MFS-13-143A, Wide Track, I-Beam Type, 13,200-lb Capacity |
| FRONT SPRING SUSPENSION | Multileaf, Shackle Type; 14,000-lb Capacity; With Shock Absorbers |
| EXHAUST SYSTEM | EGR: Single, Vertical Aftertreatment Device Frame Mounted Right Side; Includes Vertical Tail Pipe & Guard SCR: Switchback Horizontal Aftertreatment Device, Frame Mounted Right Side Under Cab; Includes Single Vertical Tail Pipe, Frame Mounted Right Side Back of Cab |
| ALTERNATOR | Bosch LH160, 12 Volt 160 Amp. Capacity |
| BATTERY BOX | Aluminum With Plastic Cover, 18" Wide, Mounted Right Back of Cab |
| TANDEM REAR AXLE | Meritor MT-40-14X-4DFR-P, Single Reduction, 0.433"(11mm) Wall Housing Thickness, 40,000-lb Capacity, R Wheel Ends, With Lube Oil Pump |
| REAR SUSPENSION, TANDEM | Hendrickson HMX-400-54, Walking Beam Type 54" Axle Spacing; 40,000-lb Capacity, With Rubber End Bushings, Transverse Torque Rods, Less Shock Absorbers |
| FUEL TANK | Non-Polished Aluminum, 24" Diam., 80 U.S. Gal., 302 L Capacity Mounted Left Side Under Cab Non-Polished Aluminum, 24" Diam., 80 U.S. Gal., 302 L Capacity Mounted Right Side Under Cab Top Draw; Non-Polished Aluminum, 26" Diam., 80 U.S. Gal., 302 L Capacity |
| FRONT WHEELS | 22.5" Painted Steel, 2 Hand Hole, 10 Stud (285.75MM BC) Hub Piloted, Flanged Nut, Metric Mount, 8.25 DC Rims; With Steel Hubs. |
| REAR WHEELS | 22.5" Painted Steel, 2 Hand Hole, 10-Stud (285.75MM BC) Hub Piloted, Flanged Nut, Metric Mount, 8.25 DC Rims; With Steel Hubs |

CT660 116BBC 6x4 SPECIFICATIONS

CHASSIS DIAGRAMS — PLAN VIEW (EGR ONLY)

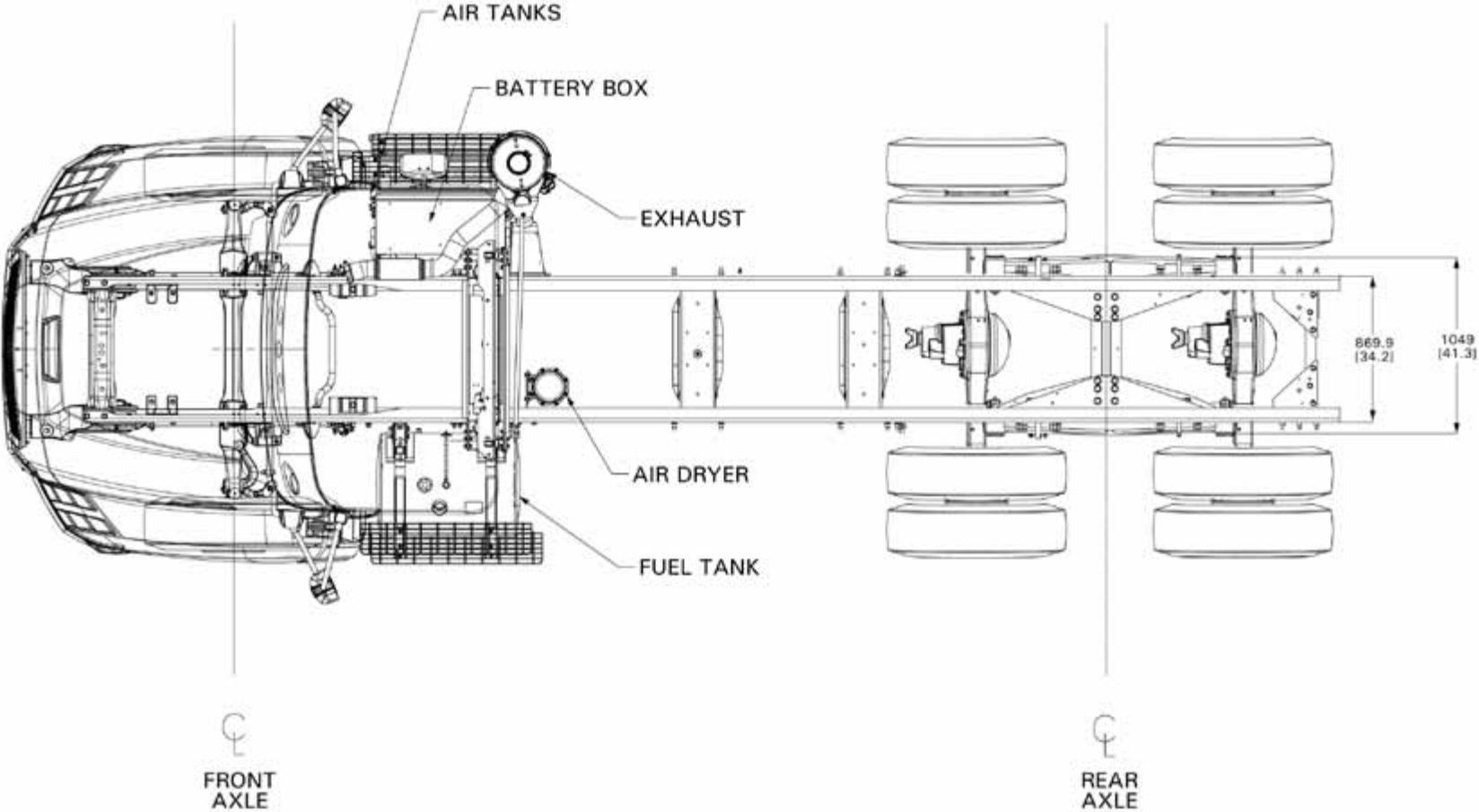

NOTE: This drawing should not be used to determine crossmember location – this information can be found later in the book.

[↶ return to table of contents](#)

CT660 SCR 116BBC 6x4 SPECIFICATIONS

CHASSIS DIAGRAMS — PLAN VIEW (SCR ONLY)

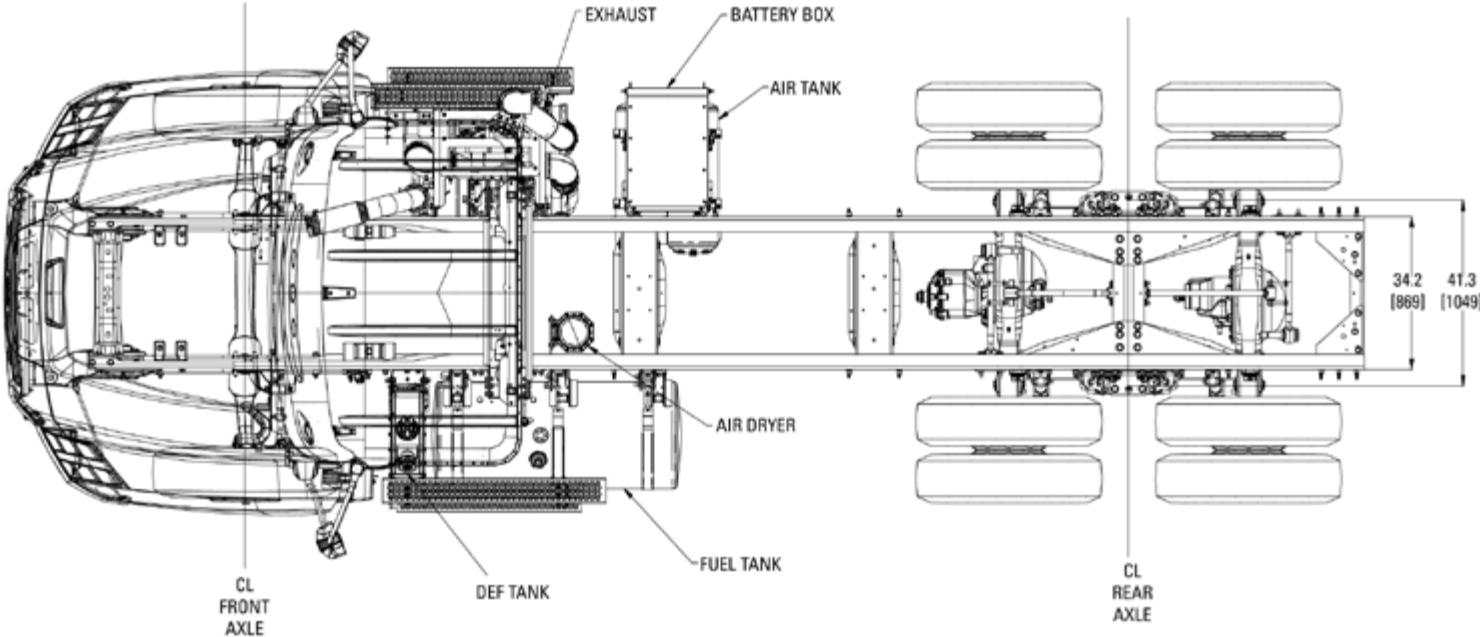

NOTE: This drawing should not be used to determine crossmember location – this information can be found later in the book.

[↶ return to table of contents](#)

CT660 116BBC 6x4 SPECIFICATIONS

CHASSIS DIAGRAMS — SIDE VIEW (EGR ONLY)

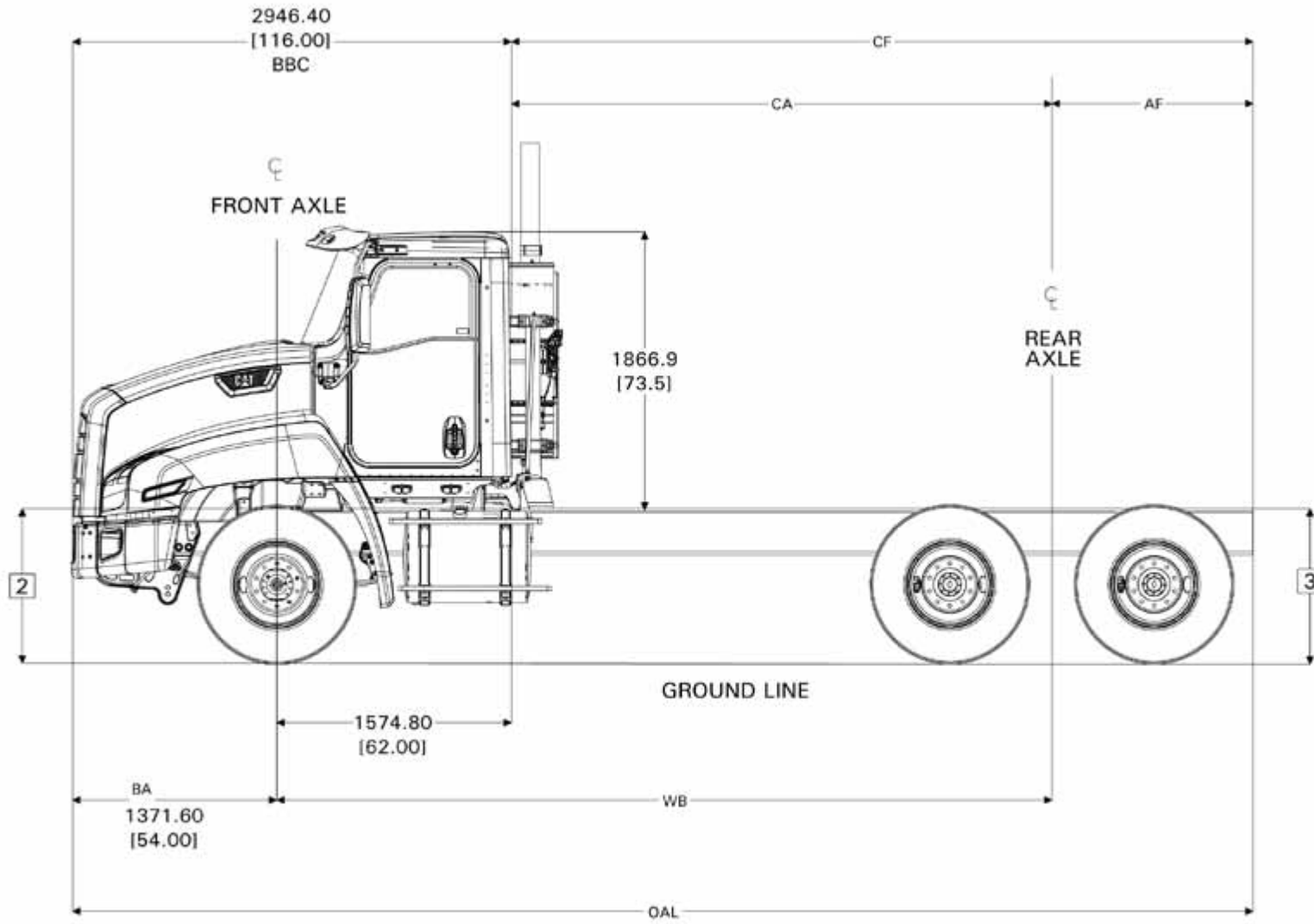

NOTE: This drawing should not be used to determine crossmember location – this information can be found later in the book.

[↶ return to table of contents](#)

CT660 116BBC 8x6 SPECIFICATIONS

WEIGHT/DIMENSIONS/TURNING RADIUS (EGR ONLY)

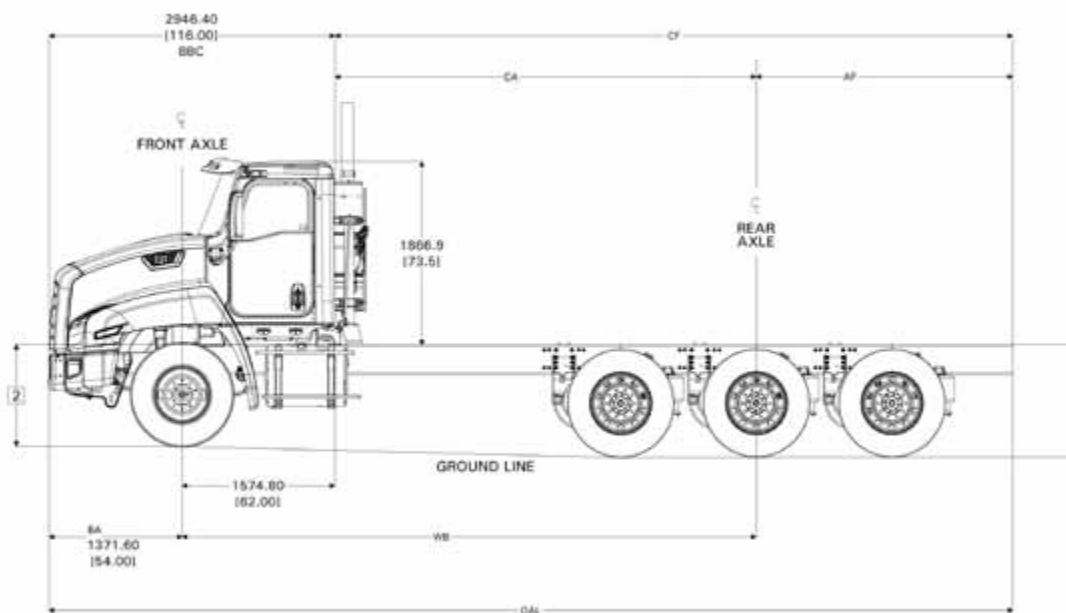

| WHEELBASE (IN.) | CHASSIS WEIGHT (LBS) ** | | | DIMENSIONS (IN.) | | | | TURNING RADIUS | |
|-----------------|-------------------------|--------|--------|------------------|-----|-----|-----|----------------|---------------------|
| | FRONT | REAR | TOTAL | CA | CF | AF | OAL | TO CURB | W/ BUMPER CLEARANCE |
| 250 | 9,237 | 11,034 | 20,271 | 188 | 292 | 104 | 408 | 39 ft. 10 in. | 41 ft. 4 in. |
| 252 | | | | 190 | 294 | 104 | 410 | 40 ft. 2 in. | 41ft. 7 in. |
| 286 | | | | 224 | 328 | 104 | 444 | 44 ft. 9 in. | 46 ft. |
| 321 | | | | 258.9 | 363 | 104 | 479 | 50 ft. 3 in. | 51 ft. 8 in. |

** Weight includes standard chassis, standard tires, oil and water, but less fuel.

NOTE: This drawing should not be used to determine crossmember location – this information can be found later in the book.

↪ return to table of contents

CT660 SCR 116BBC 8x6 SPECIFICATIONS

WEIGHT/DIMENSIONS/TURNING RADIUS (SCR ONLY)

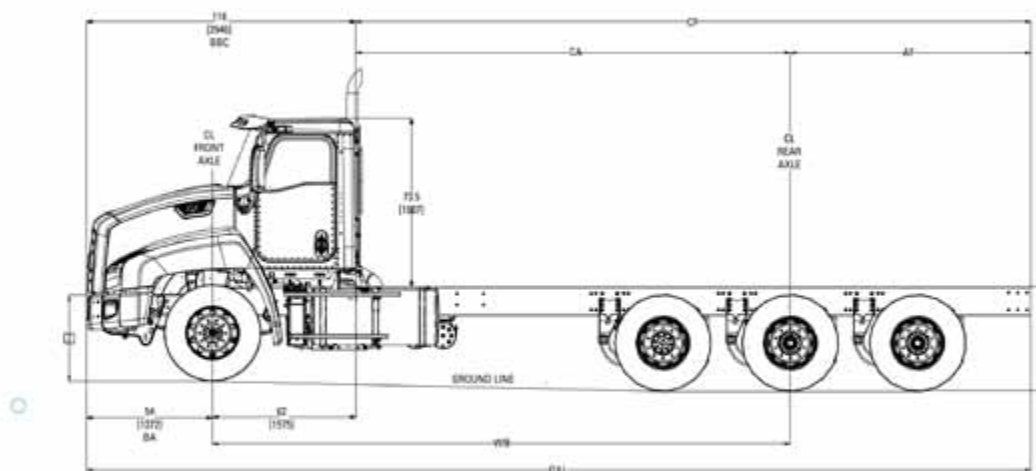

| WHEELBASE (IN.) | CHASSIS WEIGHT (LBS) ** | | | DIMENSIONS (IN.) | | | | TURNING RADIUS | |
|-----------------|-------------------------|-------|--------|------------------|-----|-----|-----|----------------|---------------------|
| | FRONT | REAR | TOTAL | CA | CF | AF | OAL | TO CURB | W/ BUMPER CLEARANCE |
| 250 | 10,176 | 9,397 | 19,573 | 188 | 292 | 104 | 408 | 39 ft. 10 in. | 41 ft. 4 in. |
| 252 | | | | 190 | 294 | 104 | 410 | 40 ft. 2 in. | 41ft. 7 in. |
| 286 | | | | 224 | 328 | 104 | 444 | 44 ft. 9 in. | 46 ft. |
| 321 | | | | 258.9 | 363 | 104 | 479 | 50 ft. 3 in. | 51 ft. 8 in. |

** Weight includes standard chassis, standard tires, oil and water, but less fuel.

NOTE: This drawing should not be used to determine crossmember location – this information can be found later in the book.

↪ return to table of contents

CT660 116BBC 8x6 SPECIFICATIONS

STANDARD FEATURES

| FEATURE | SPECIFICATION |
|------------------------------------|---|
| FRAME RAILS | FRAME RAILS Heat Treated Alloy Steel (120,000 PSI Yield); 12.250" x 3.380" x 0.375" (304.8mm x 85.6mm x 9.5mm); 543.0" (13793mm) Maximum Frame Length |
| FRONT NON-DRIVING AXLE | Meritor MFS-16-143A, Wide Track, I-Beam Type, 16,000-lb Capacity |
| FRONT SPRING SUSPENSION | Multileaf, Shackle Type; 16,000-lb Capacity; Less Shock Absorbers |
| EXHAUST SYSTEM | EGR: Single, Vertical Aftertreatment Device Frame Mounted Right Side; Includes Vertical Tail Pipe & Guard SCR: Switchback Horizontal Aftertreatment Device, Frame Mounted Right Side Under Cab; Includes Single Vertical Tail Pipe, Frame Mounted Right Side Back of Cab |
| ALTERNATOR | Bosch LH160, 12 Volt 160 Amp. Capacity |
| BATTERY BOX | Aluminum With Plastic Cover, 18" Wide, Mounted Right Side Back of Cab |
| TRIDEM REAR AXLE | Meritor RZ-166 EH, Single Reduction, Wide Track, 53,000-lb Capacity, With Driver Controlled Locking Differential in All Three Axles and 200 Wheel Ends |
| REAR AIR SUSPENSION, TRIDEM | Neway AD-369, 55" Axle Spacing; 69,000-lb Capacity, 10.00" Ride Height, With Shock Absorbers |
| FUEL TANK | Non-Polished Aluminum, 24" Diam., 80 U.S. Gal., 302 L Capacity Mounted Left Side Under Cab Non-Polished Aluminum, 24" Diam., 80 U.S. Gal., 302 L Capacity Mounted Right Side Under Cab Top Draw; Non-Polished Aluminum, 26" Diam., 80 U.S. Gal., 302 L Capacity |
| FRONT WHEELS | 22.5" Painted Steel, 2 Hand Hole, 10 Stud (285.75MM BC) Hub Piloted, Flanged Nut, Metric Mount, 8.25 DC Rims; With Steel Hubs. |
| REAR WHEELS | 22.5" Painted Steel, 2 Hand Hole, 10-Stud (285.75MM BC) Hub Piloted, Flanged Nut, Metric Mount, 8.25 DC Rims; With Steel Hubs |

CT660 116BBC 8x6 SPECIFICATIONS

CHASSIS DIAGRAMS — PLAN VIEW (EGR ONLY)

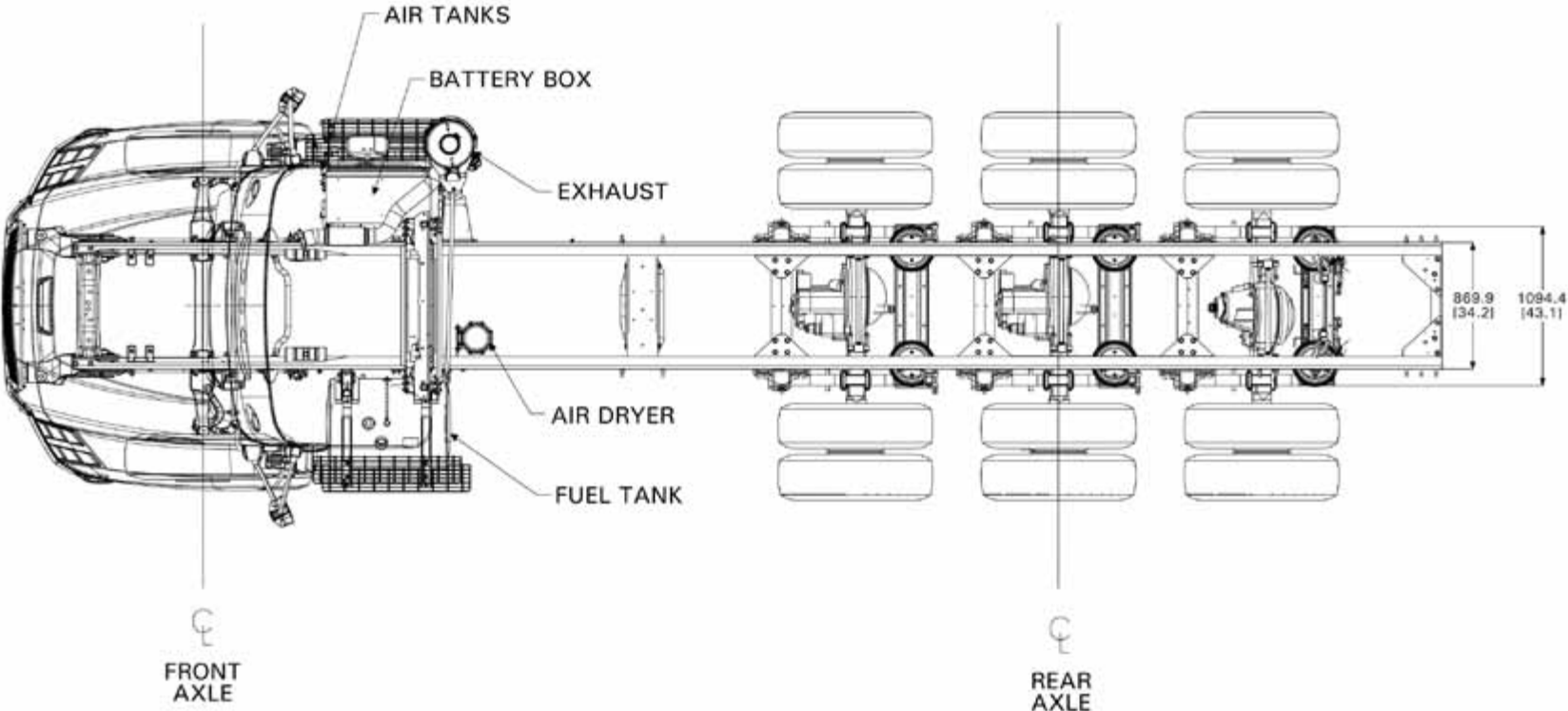

NOTE: This drawing should not be used to determine crossmember location – this information can be found later in the book.

[↶ return to table of contents](#)

CT660 SCR 116BBC 8x6 SPECIFICATIONS

CHASSIS DIAGRAMS — PLAN VIEW (SCR ONLY)

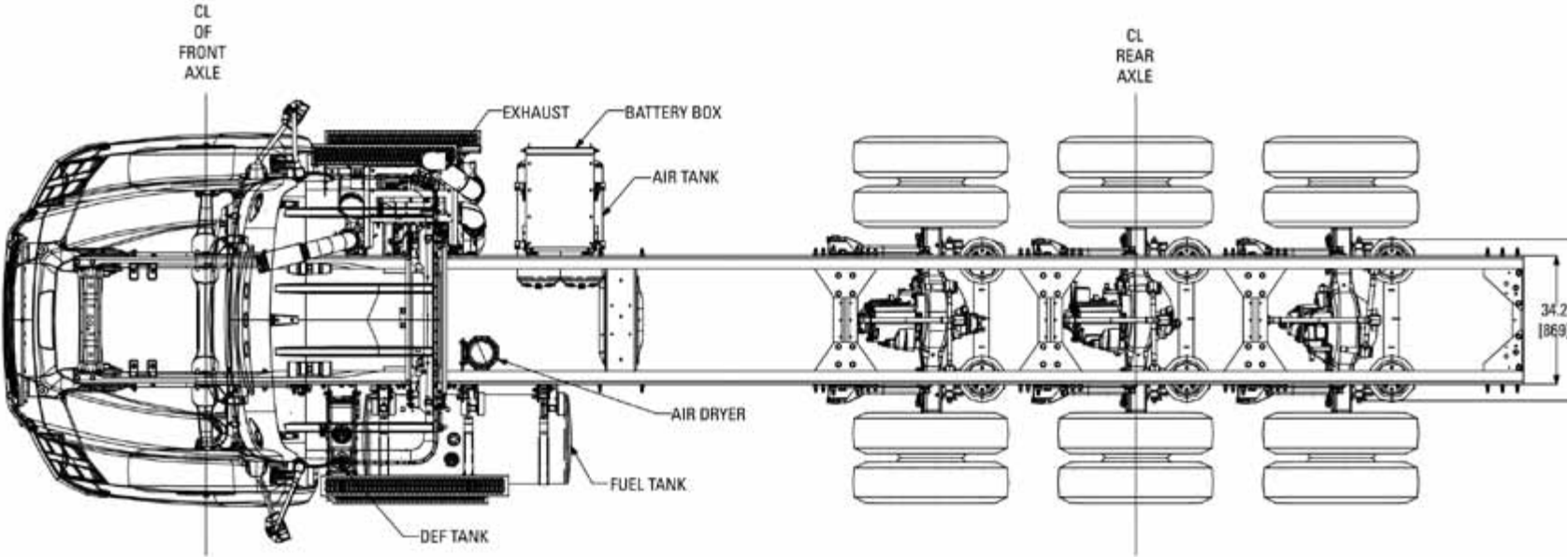

NOTE: This drawing should not be used to determine crossmember location – this information can be found later in the book.

[↶ return to table of contents](#)

CT660 116BBC 8x6 SPECIFICATIONS

CHASSIS DIAGRAMS — SIDE VIEW (EGR ONLY)

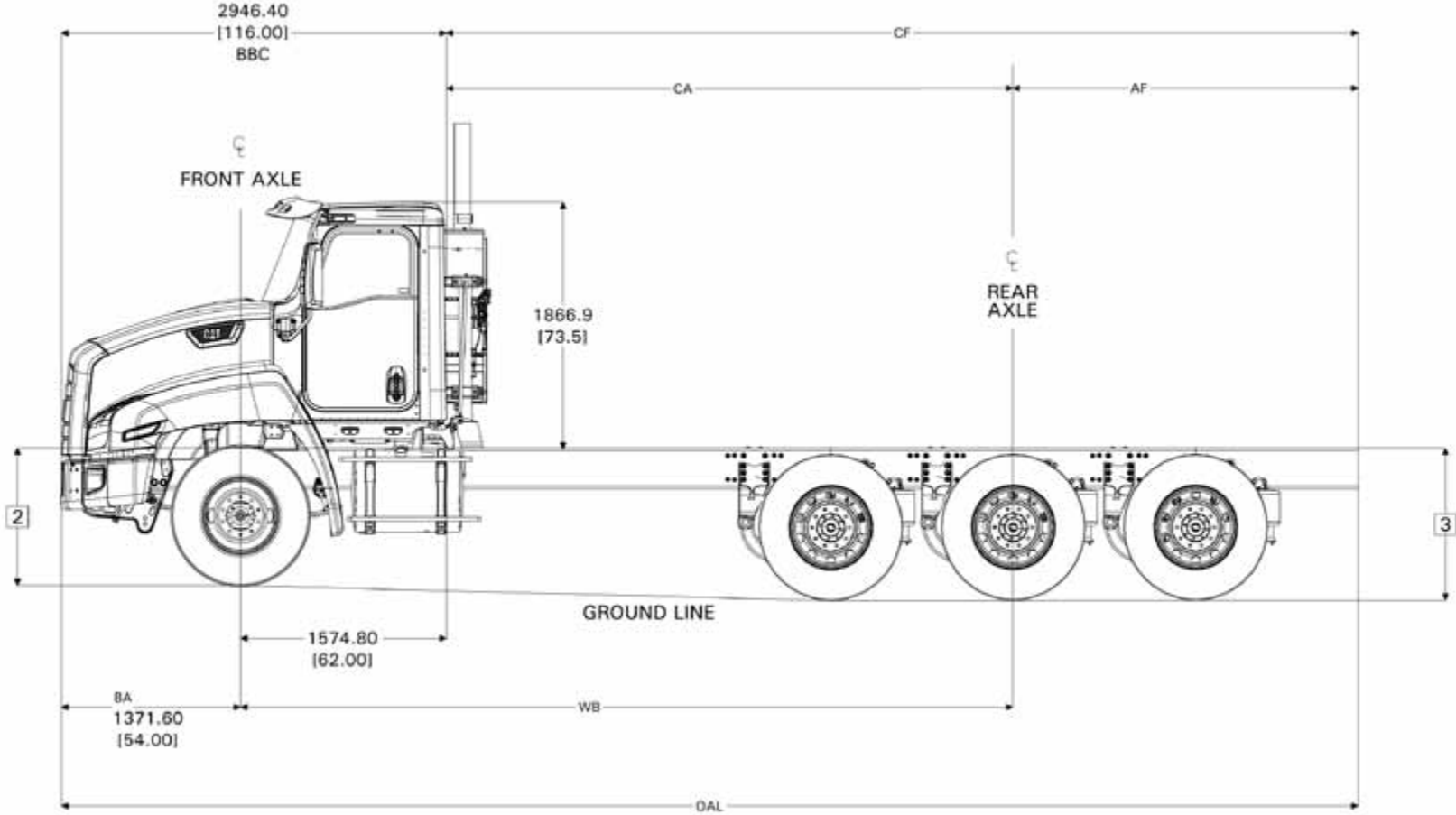

NOTE: This drawing should not be used to determine crossmember location – this information can be found later in the book.

[↶ return to table of contents](#)

CT660 SCR 116BBC 8x6 SPECIFICATIONS

CHASSIS DIAGRAMS — SIDE VIEW (SCR ONLY)

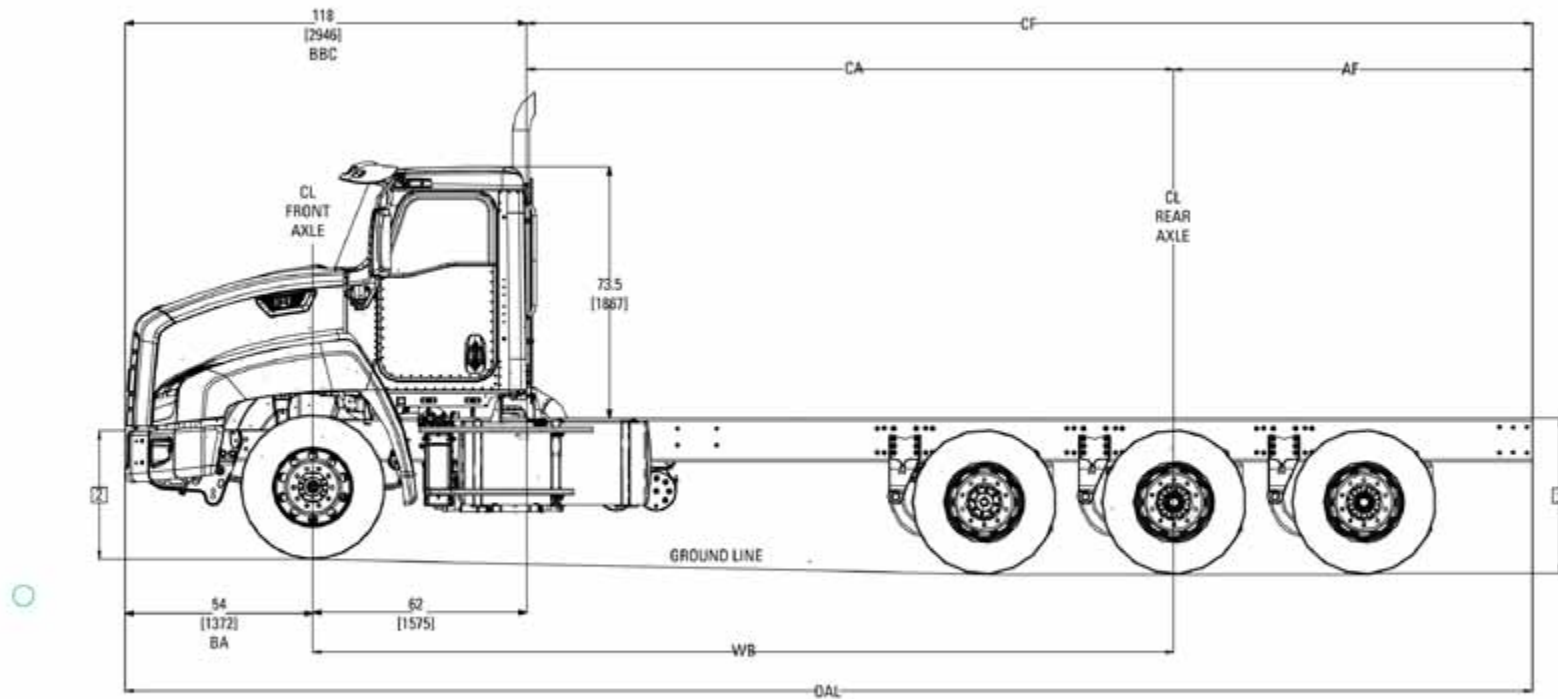

NOTE: This drawing should not be used to determine crossmember location – this information can be found later in the book.

[↶ return to table of contents](#)

CT660 CT11/13 122BBC 6x4 SPECIFICATIONS

WEIGHT/DIMENSIONS/TURNING RADIUS (EGR ONLY)

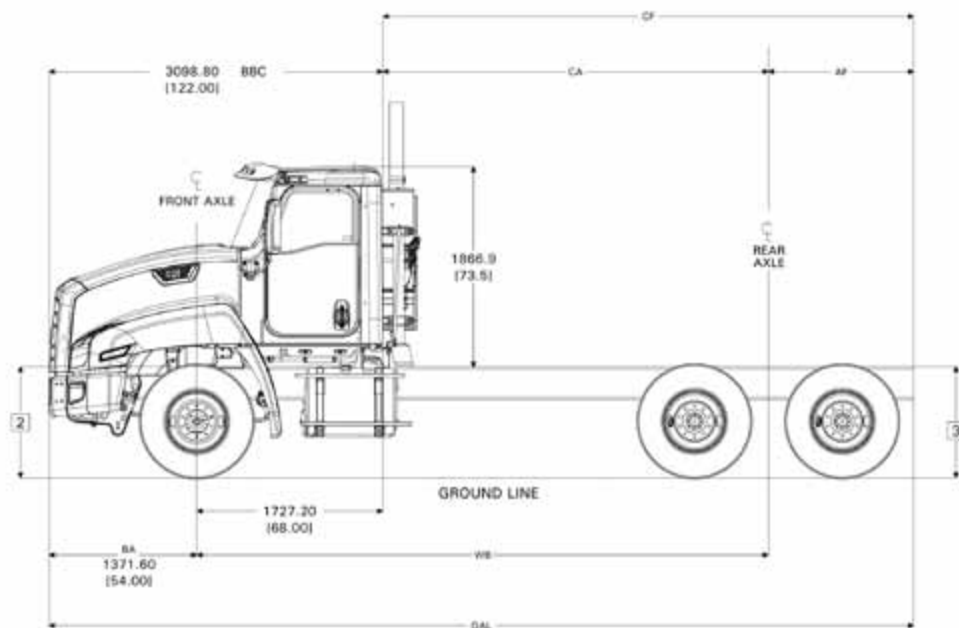

| WHEELBASE (IN.) | CHASSIS WEIGHT (LBS) ** | | | DIMENSIONS (IN.) | | | | TURNING RADIUS | |
|-----------------|-------------------------|-------|--------|------------------|-------|----|-------|----------------|---------------------|
| | FRONT | REAR | TOTAL | CA | CF | AF | OAL | TO CURB | W/ BUMPER CLEARANCE |
| 171 | | | | 103.1 | 156.1 | 53 | 277.8 | 28 ft. 0 in. | 29 ft. 5 in. |
| 181 | | | | 113.1 | 166.1 | 53 | 288.1 | 30 ft. 8 in. | 32 ft. 1 in. |
| 199 | 9,436 | 6,916 | 16,352 | 130.8 | 183.8 | 53 | 305.8 | 33 ft. 5 in. | 34 ft. 10 in. |
| 211 | | | | 142.6 | 195.6 | 53 | 317.6 | 35 ft. 2 in. | 36 ft. 8 in. |

** Weight includes standard chassis, standard tires, oil and water, but less fuel.

NOTE: This drawing should not be used to determine crossmember location – this information can be found later in the book.

↪ return to table of contents

CT660 SCR CT13 122BBC 6x4 SPECIFICATIONS

WEIGHT/DIMENSIONS/TURNING RADIUS (SCR ONLY)

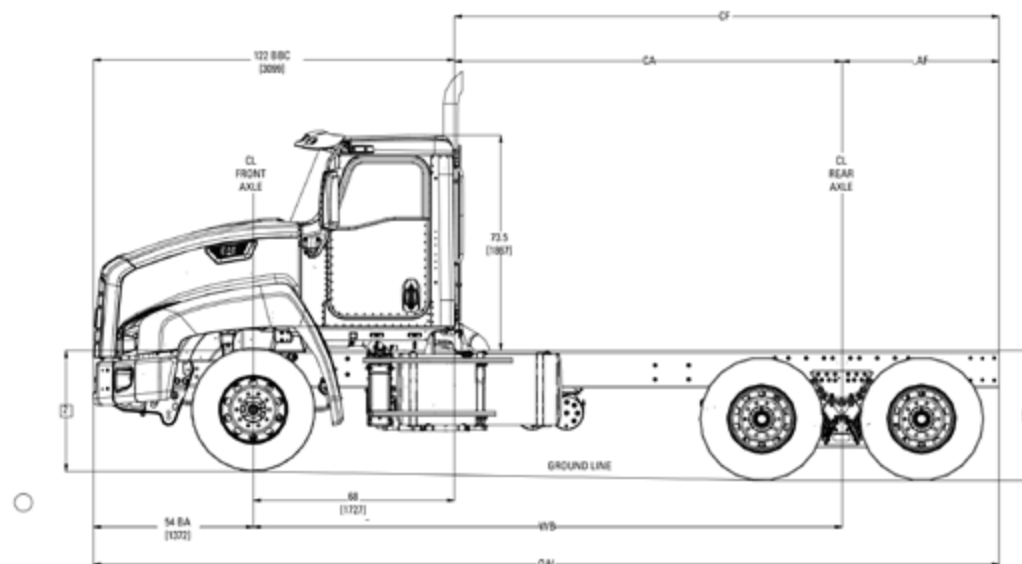

| WHEELBASE (IN.) | CHASSIS WEIGHT (LBS) ** | | | DIMENSIONS (IN.) | | | | TURNING RADIUS | |
|-----------------|-------------------------|-------|--------|------------------|-------|----|-------|----------------|---------------------|
| | FRONT | REAR | TOTAL | CA | CF | AF | OAL | TO CURB | W/ BUMPER CLEARANCE |
| 171 | | | | 103.1 | 156.1 | 53 | 277.8 | 28 ft. 0 in. | 29 ft. 5 in. |
| 181 | | | | 113.1 | 166.1 | 53 | 288.1 | 30 ft. 8 in. | 32 ft. 1 in. |
| 199 | 9,509 | 7,028 | 16,537 | 130.8 | 183.8 | 53 | 305.8 | 33 ft. 5 in. | 34 ft. 10 in. |
| 211 | | | | 142.6 | 195.6 | 53 | 317.6 | 35 ft. 2 in. | 36 ft. 8 in. |

** Weight includes standard chassis, standard tires, oil and water, but less fuel.

NOTE: This drawing should not be used to determine crossmember location – this information can be found later in the book.

↪ return to table of contents

CT660 CT15 122BBC 6x4 SPECIFICATIONS

WEIGHT/DIMENSIONS/TURNING RADIUS (EGR ONLY)

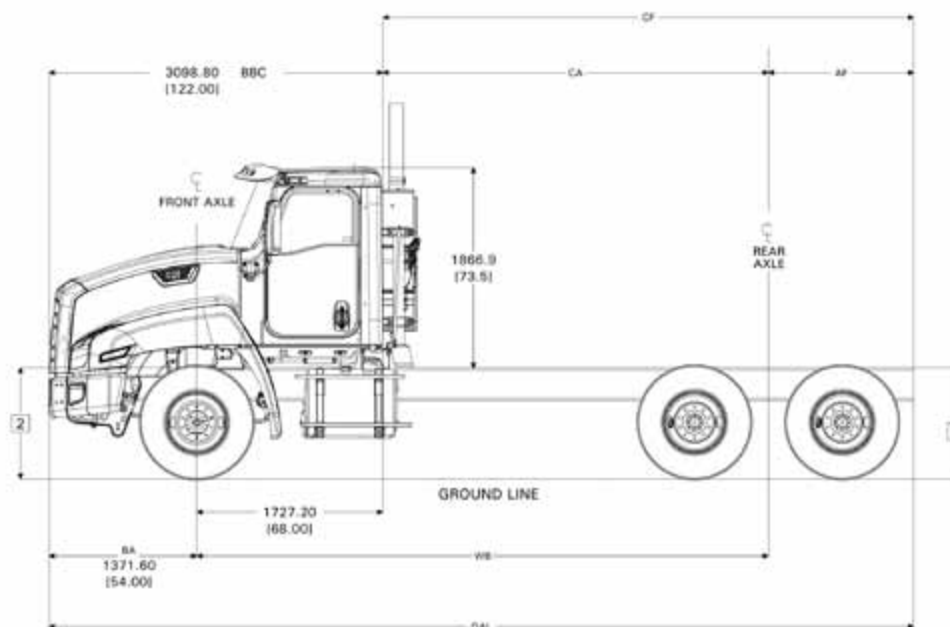

| WHEELBASE (IN.) | CHASSIS WEIGHT (LBS) ** | | | DIMENSIONS (IN.) | | | | TURNING RADIUS | |
|-----------------|-------------------------|-------|--------|------------------|-------|----|-------|----------------|---------------------|
| | FRONT | REAR | TOTAL | CA | CF | AF | OAL | TO CURB | W/ BUMPER CLEARANCE |
| 171 | | | | 103.1 | 156.1 | 53 | 277.8 | 28 ft. 0 in. | 29 ft. 5 in. |
| 181 | | | | 113.1 | 166.1 | 53 | 288.1 | 30 ft. 8 in. | 32 ft. 1 in. |
| 199 | 11,400 | 6,965 | 20,365 | 130.8 | 183.8 | 53 | 305.8 | 33 ft. 5 in. | 34 ft. 10 in. |
| 211 | | | | 142.6 | 195.6 | 53 | 317.6 | 35 ft. 2 in. | 36 ft. 8 in. |

** Weight includes standard chassis, standard tires, oil and water, but less fuel.

NOTE: This drawing should not be used to determine crossmember location – this information can be found later in the book.

↪ return to table of contents

CT660 122BBC 6x4 SPECIFICATIONS

STANDARD FEATURES

| FEATURE | SPECIFICATION |
|--------------------------------|---|
| FRAME RAILS | FRAME RAILS Heat Treated Alloy Steel (120,000 PSI Yield); 12.250" x 3.380" x 0.375" (304.8mm x 85.6mm x 9.5mm); 543.0" (13793mm) Maximum Frame Length |
| FRONT NON-DRIVING AXLE | Meritor MFS-13-143A, Wide Track, I-Beam Type, 13,200-lb Capacity |
| FRONT SPRING SUSPENSION | Multileaf, Shackle Type; 14,000-lb Capacity; With Shock Absorbers |
| EXHAUST SYSTEM | EGR: Single, Vertical Aftertreatment Device Frame Mounted Right Side; Includes Vertical Tail Pipe & Guard SCR: Switchback Horizontal Aftertreatment Device, Frame Mounted Right Side Under Cab; Includes Single Vertical Tail Pipe, Frame Mounted Right Side Back of Cab |
| ALTERNATOR | Bosch LH160, 12 Volt 160 Amp. Capacity |
| BATTERY BOX | Aluminum With Plastic Cover, 18" Wide, Mounted Right or Right Side Back of Cab |
| TANDEM REAR AXLE | Meritor MT-40-14X-4DFR-P, Single Reduction, 0.433"(11mm) Wall Housing Thickness, 40,000-lb Capacity, R Wheel Ends, With Lube Oil Pump |
| REAR SUSPENSION, TANDEM | Hendrickson HMX-400-54, Walking Beam Type 54" Axle Spacing; 40,000-lb Capacity, With Rubber End Bushings, Transverse Torque Rods, Less Shock Absorbers |
| FUEL TANK | Non-Polished Aluminum, 24" Diam., 80 U.S. Gal., 302 L Capacity Mounted Left Side Under Cab Non-Polished Aluminum, 24" Diam., 80 U.S. Gal., 302 L Capacity Mounted Right Side Under Cab Top Draw; Non-Polished Aluminum, 26" Diam., 80 U.S. Gal., 302 L Capacity |
| FRONT WHEELS | 22.5" Painted Steel, 2 Hand Hole, 10 Stud (285.75MM BC) Hub Piloted, Flanged Nut, Metric Mount, 8.25 DC Rims; With Steel Hubs. |
| REAR WHEELS | 22.5" Painted Steel, 2 Hand Hole, 10- Stud (285.75MM BC) Hub Piloted, Flanged Nut, Metric Mount, 8.25 DC Rims; With Steel Hubs |

CT660 122BBC 6x4 SPECIFICATIONS

CHASSIS DIAGRAMS — PLAN VIEW (EGR ONLY)

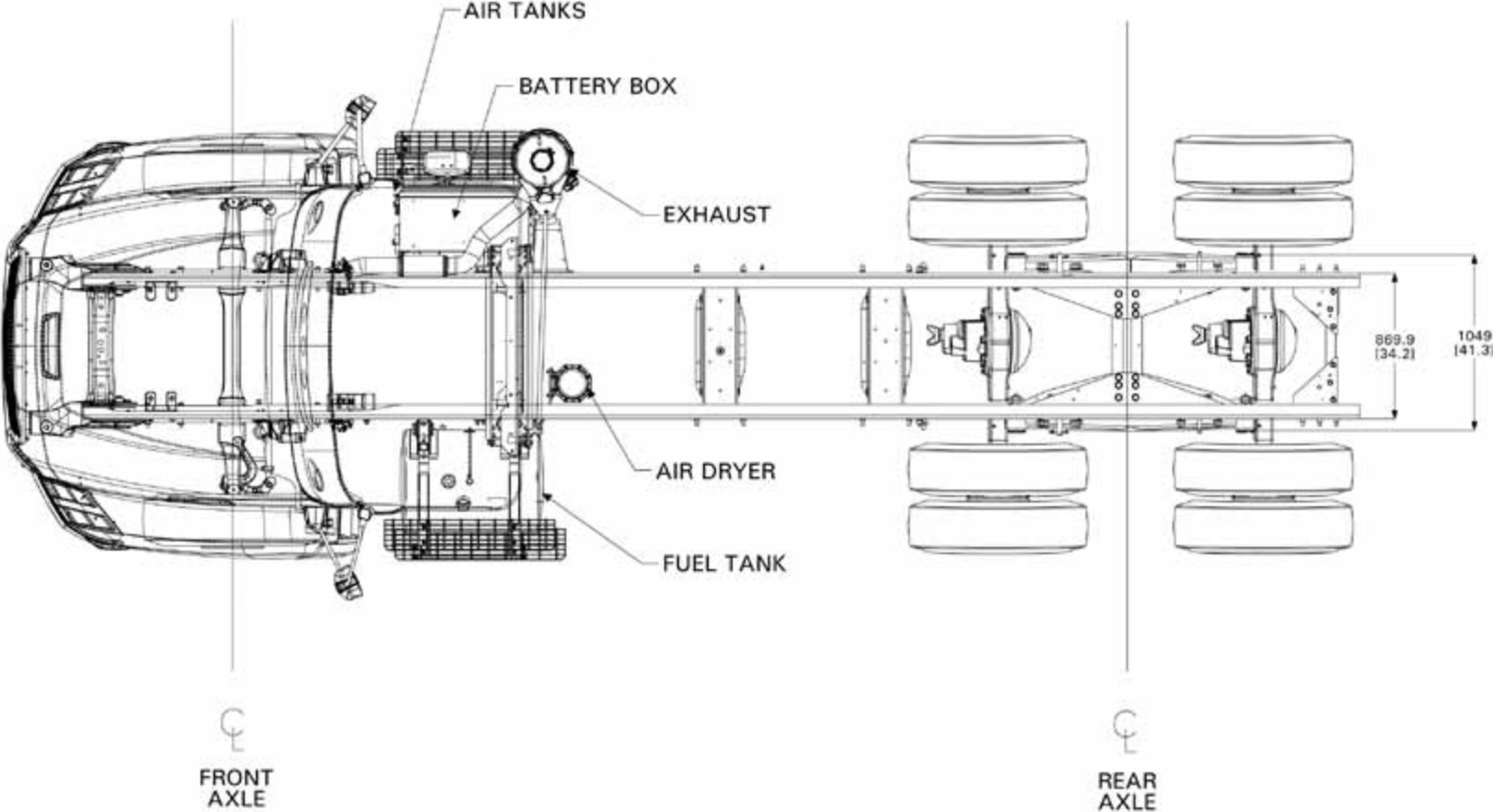

NOTE: This drawing should not be used to determine crossmember location – this information can be found later in the book.

[↶ return to table of contents](#)

CT660 SCR 122BBC 6x4 SPECIFICATIONS

CHASSIS DIAGRAMS — PLAN VIEW (SCR ONLY)

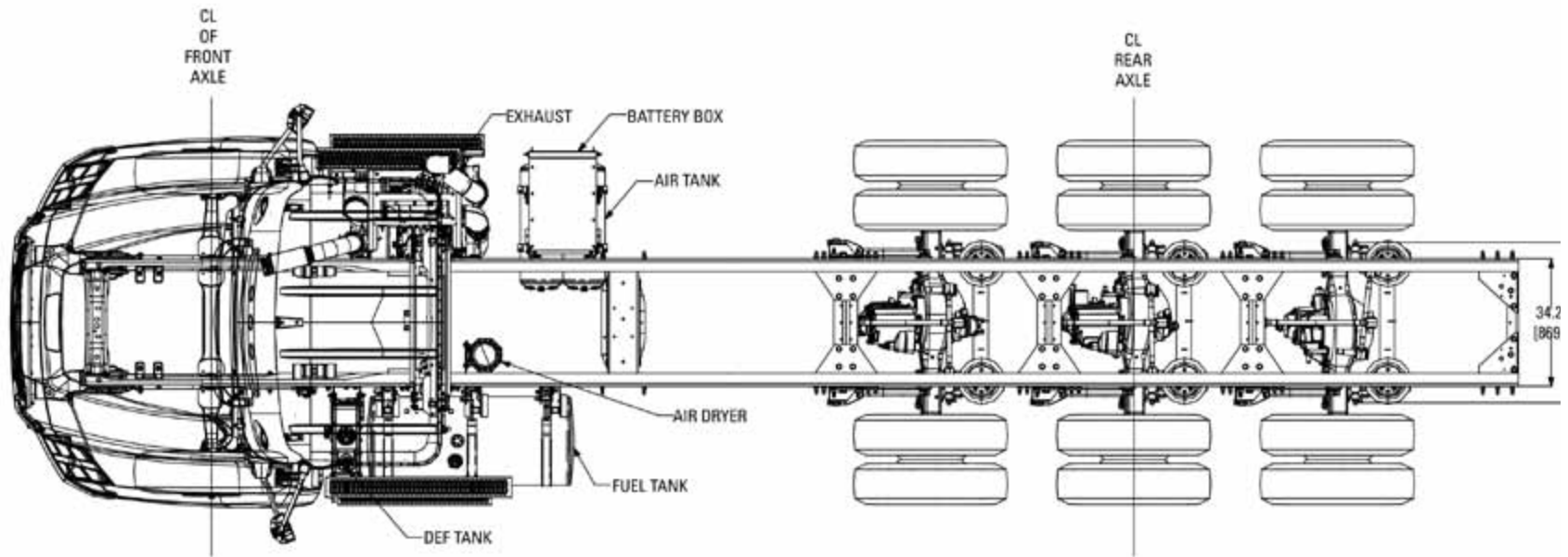

NOTE: This drawing should not be used to determine crossmember location – this information can be found later in the book.

[↶ return to table of contents](#)

CT660 122BBC 6x4 SPECIFICATIONS

CHASSIS DIAGRAMS — SIDE VIEW (EGR ONLY)

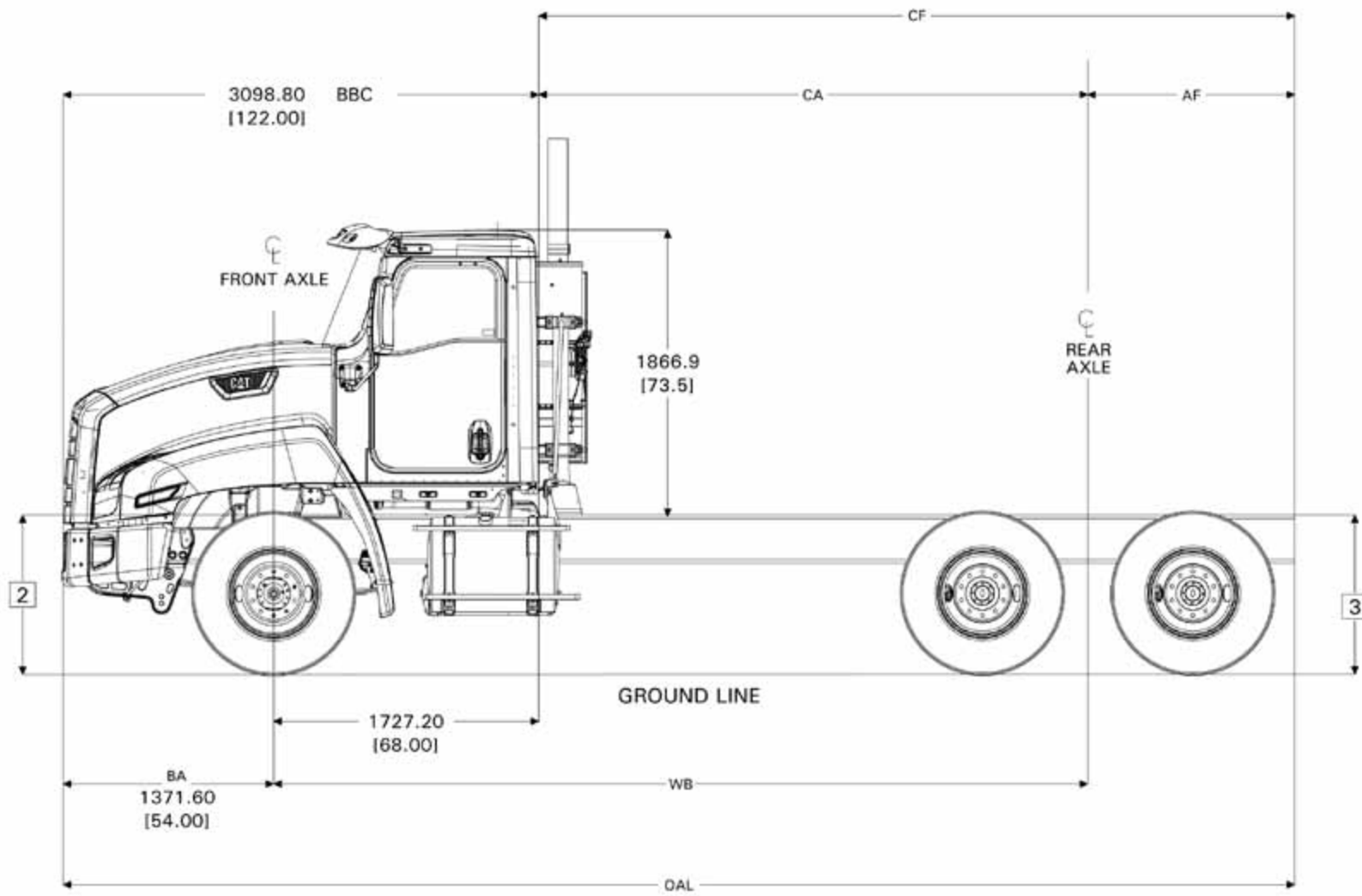

NOTE: This drawing should not be used to determine crossmember location – this information can be found later in the book.

[↶ return to table of contents](#)

CT660 SCR 122BBC 6x4 SPECIFICATIONS

CHASSIS DIAGRAMS — SIDE VIEW (SCR ONLY)

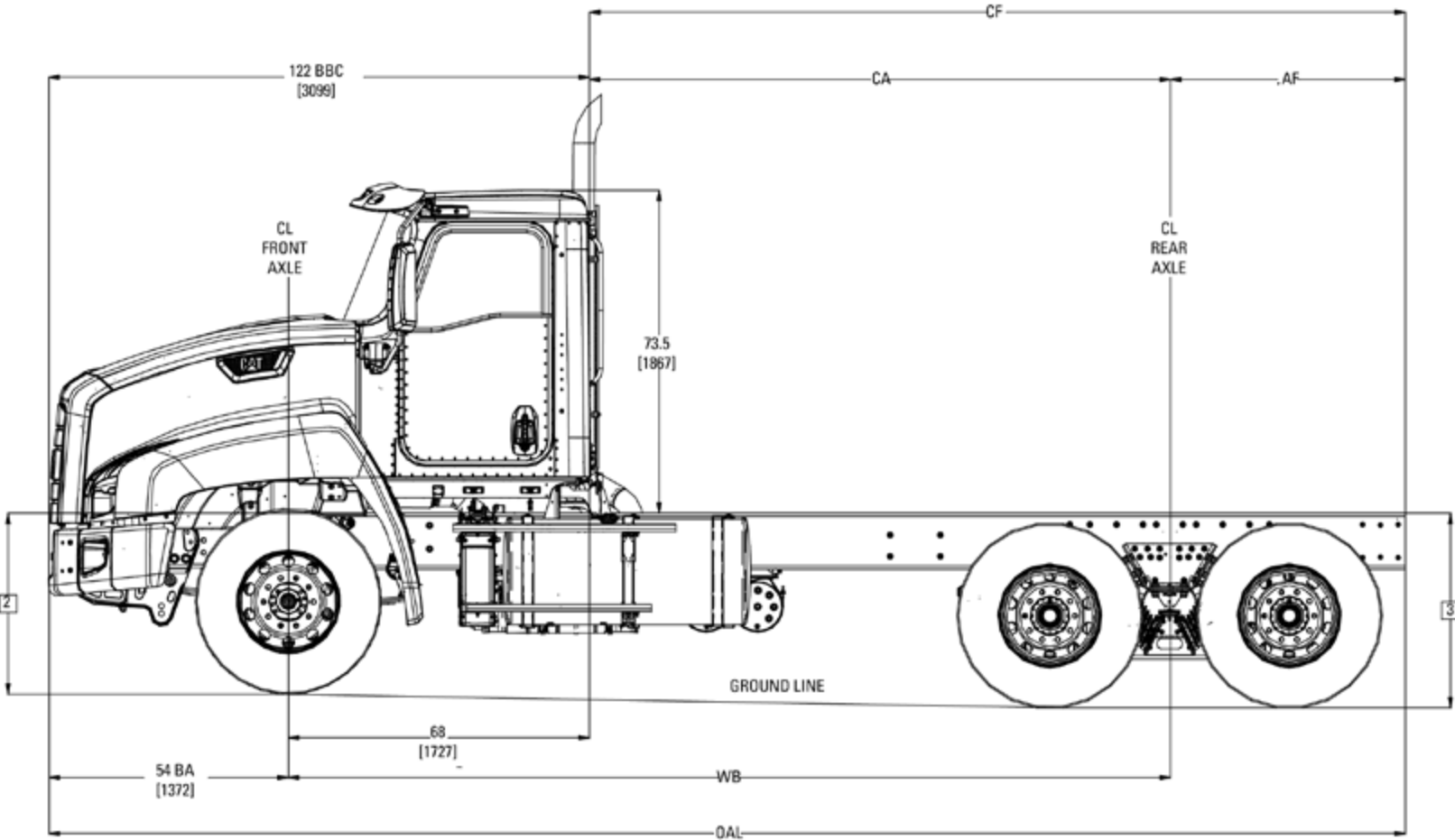

NOTE: This drawing should not be used to determine crossmember location – this information can be found later in the book.

[↶ return to table of contents](#)

CT660 CT11/13 122BBC 8x6 SPECIFICATIONS

WEIGHT/DIMENSIONS/TURNING RADIUS (EGR ONLY)

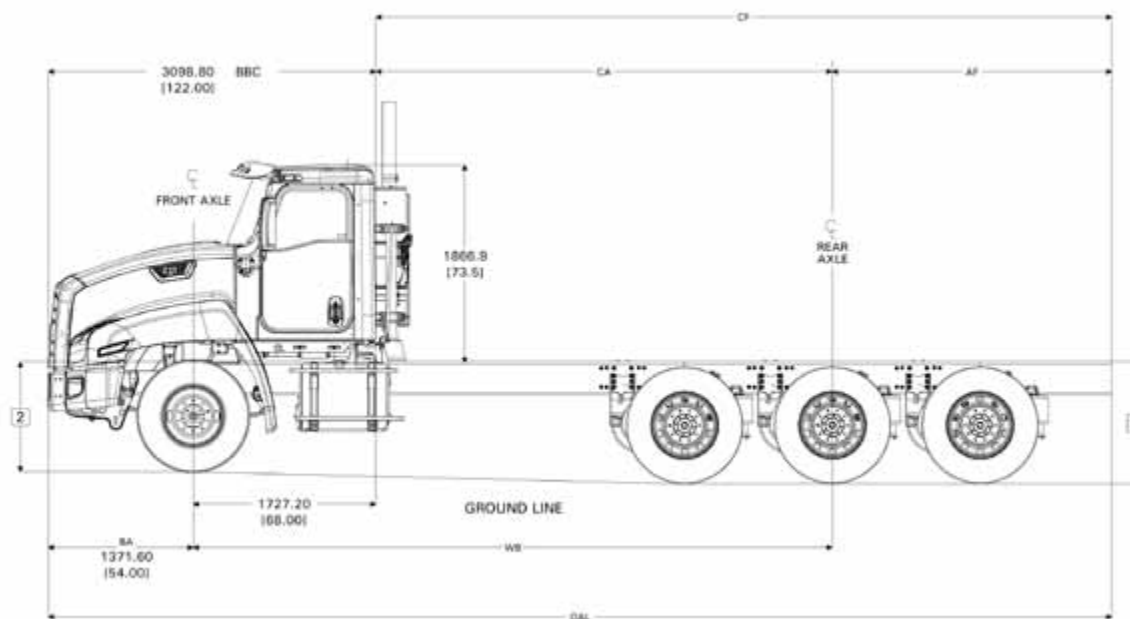

| WHEELBASE (IN.) | CHASSIS WEIGHT (LBS) ** | | | DIMENSIONS (IN.) | | | | TURNING RADIUS | |
|-----------------|-------------------------|--------|--------|------------------|-------|-----|-------|----------------|---------------------|
| | FRONT | REAR | TOTAL | CA | CF | AF | OAL | TO CURB | W/ BUMPER CLEARANCE |
| 250 | 9,237 | 11,034 | 20,271 | 182 | 286 | 104 | 408 | 39 ft. 10 in. | 41 ft. 4 in. |
| 252 | | | | 184 | 288 | 104 | 410 | 40 ft. 2 in. | 41 ft. 7 in. |
| 286 | | | | 218 | 322 | 104 | 444 | 44 ft. 9 in. | 46 ft. 0 in. |
| 321 | | | | 252.9 | 356.9 | 104 | 478.9 | 50 ft. 3 in. | 51 ft. 8 in. |

** Weight includes standard chassis, standard tires, oil and water, but less fuel.

NOTE: This drawing should not be used to determine crossmember location – this information can be found later in the book.

↪ return to table of contents

CT660 SCR CT13 122BBC 8x6 SPECIFICATIONS

WEIGHT/DIMENSIONS/TURNING RADIUS (SCR ONLY)

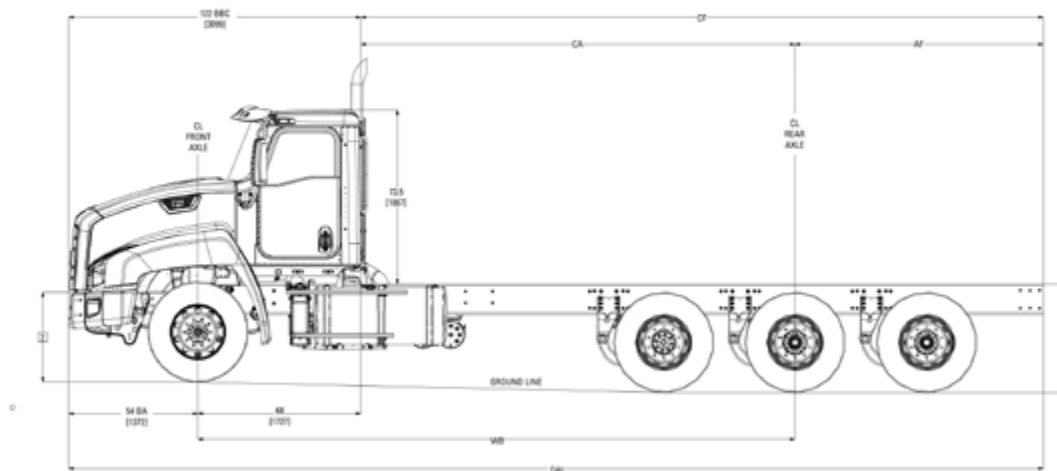

| WHEELBASE (IN.) | CHASSIS WEIGHT (LBS) ** | | | DIMENSIONS (IN.) | | | | TURNING RADIUS | |
|-----------------|-------------------------|-------|--------|------------------|-------|-----|-------|----------------|---------------------|
| | FRONT | REAR | TOTAL | CA | CF | AF | OAL | TO CURB | W/ BUMPER CLEARANCE |
| 250 | 9,835 | 9,774 | 19,609 | 182 | 286 | 104 | 408 | 39 ft. 10 in. | 41 ft. 4 in. |
| 252 | | | | 184 | 288 | 104 | 410 | 40 ft. 2 in. | 41 ft. 7 in. |
| 286 | | | | 218 | 322 | 104 | 444 | 44 ft. 9 in. | 46 ft. 0 in. |
| 321 | | | | 252.9 | 356.9 | 104 | 478.9 | 50 ft. 3 in. | 51 ft. 8 in. |

** Weight includes standard chassis, standard tires, oil and water, but less fuel.

NOTE: This drawing should not be used to determine crossmember location – this information can be found later in the book.

[↶ return to table of contents](#)

CT660 CT15 122BBC 8x6 SPECIFICATIONS

WEIGHT/DIMENSIONS/TURNING RADIUS (EGR ONLY)

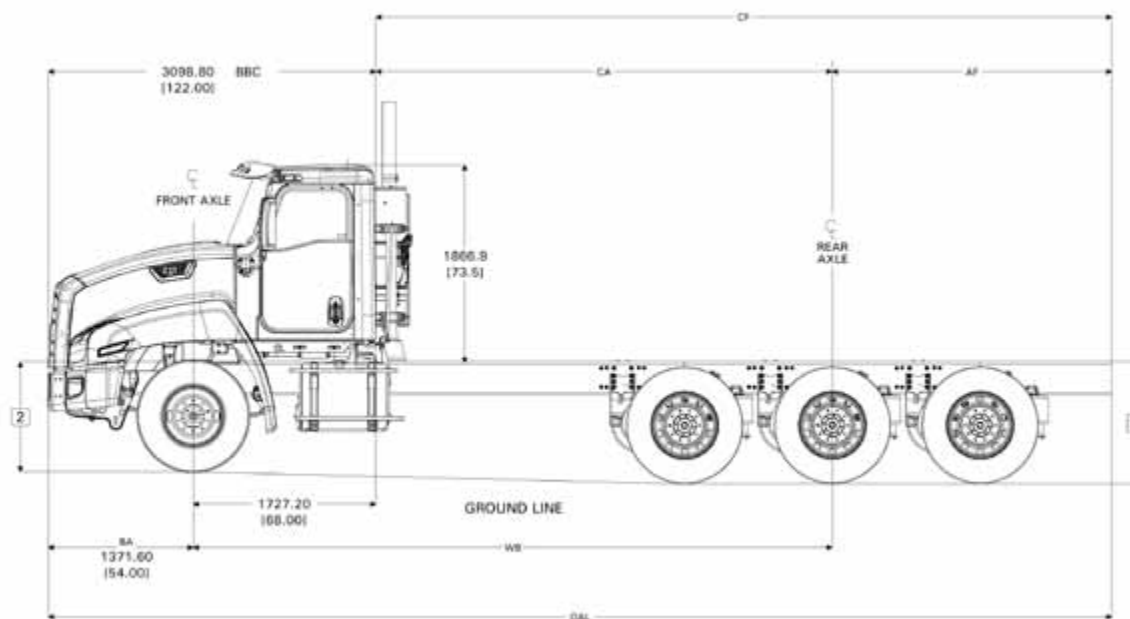

| WHEELBASE (IN.) | CHASSIS WEIGHT (LBS) ** | | | DIMENSIONS (IN.) | | | | TURNING RADIUS | |
|-----------------|-------------------------|--------|--------|------------------|-------|-----|-------|----------------|---------------------|
| | FRONT | REAR | TOTAL | CA | CF | AF | OAL | TO CURB | W/ BUMPER CLEARANCE |
| 250 | | | | 182 | 286 | 104 | 408 | 39 ft. 10 in. | 41 ft. 4 in. |
| 252 | 11,480 | 12,973 | 24,452 | 184 | 288 | 104 | 410 | 40 ft. 2 in. | 41 ft. 7 in. |
| 286 | | | | 218 | 322 | 104 | 444 | 44 ft. 9 in. | 46 ft. 0 in. |
| 321 | | | | 252.9 | 356.9 | 104 | 478.9 | 50 ft. 3 in. | 51 ft. 8 in. |

** Weight includes standard chassis, standard tires, oil and water, but less fuel.

NOTE: This drawing should not be used to determine crossmember location – this information can be found later in the book.

↪ return to table of contents

CT660 122BBC 8x6 SPECIFICATIONS

STANDARD FEATURES

| FEATURE | SPECIFICATION |
|------------------------------------|---|
| FRAME RAILS | FRAME RAILS Heat Treated Alloy Steel (120,000 PSI Yield); 12.250" x 3.380" x 0.375" (304.8mm x 85.6mm x 9.5mm); 543.0" (13793mm) Maximum Frame Length |
| FRONT NON-DRIVING AXLE | Meritor MFS-16-143A, Wide Track, I-Beam Type, 16,000-lb Capacity |
| FRONT SPRING SUSPENSION | Multileaf, Shackle Type; 16,000-lb Capacity; Less Shock Absorbers |
| EXHAUST SYSTEM | EGR: Single, Vertical Aftertreatment Device Frame Mounted Right Side; Includes Vertical Tail Pipe & Guard SCR: Switchback Horizontal Aftertreatment Device, Frame Mounted Right Side Under Cab; Includes Single Vertical Tail Pipe, Frame Mounted Right Side Back of Cab |
| ALTERNATOR | Bosch LH160, 12 Volt 160 Amp. Capacity |
| BATTERY BOX | Aluminum With Plastic Cover, 18" Wide, Mounted Right Side Back of Cab |
| TRIDEM REAR AXLE | Meritor RZ-166 EH, Single Reduction, Wide Track, 53,000-lb Capacity, With Driver Controlled Locking Differential in All Three Axles and 200 Wheel Ends |
| REAR AIR SUSPENSION, TRIDEM | Neway AD-369, 55" Axle Spacing; 69,000-lb Capacity, 10.00" Ride Height, With Shock Absorbers |
| FUEL TANK | Non-Polished Aluminum, 24" Diam., 80 U.S. Gal., 302 L Capacity Mounted Left Side Under Cab Non-Polished Aluminum, 24" Diam., 80 U.S. Gal., 302 L Capacity Mounted Right Side Under Cab Top Draw; Non-Polished Aluminum, 26" Diam., 80 U.S. Gal., 302 L Capacity |
| FRONT WHEELS | 22.5" Painted Steel, 2 Hand Hole, 10 Stud (285.75MM BC) Hub Piloted, Flanged Nut, Metric Mount, 8.25 DC Rims; With Steel Hubs. |
| REAR WHEELS | 22.5" Painted Steel, 2 Hand Hole, 10- Stud (285.75MM BC) Hub Piloted, Flanged Nut, Metric Mount, 8.25 DC Rims; With Steel Hubs |

CT660 122BBC 8x6 SPECIFICATIONS

CHASSIS DIAGRAMS — PLAN VIEW (EGR ONLY)

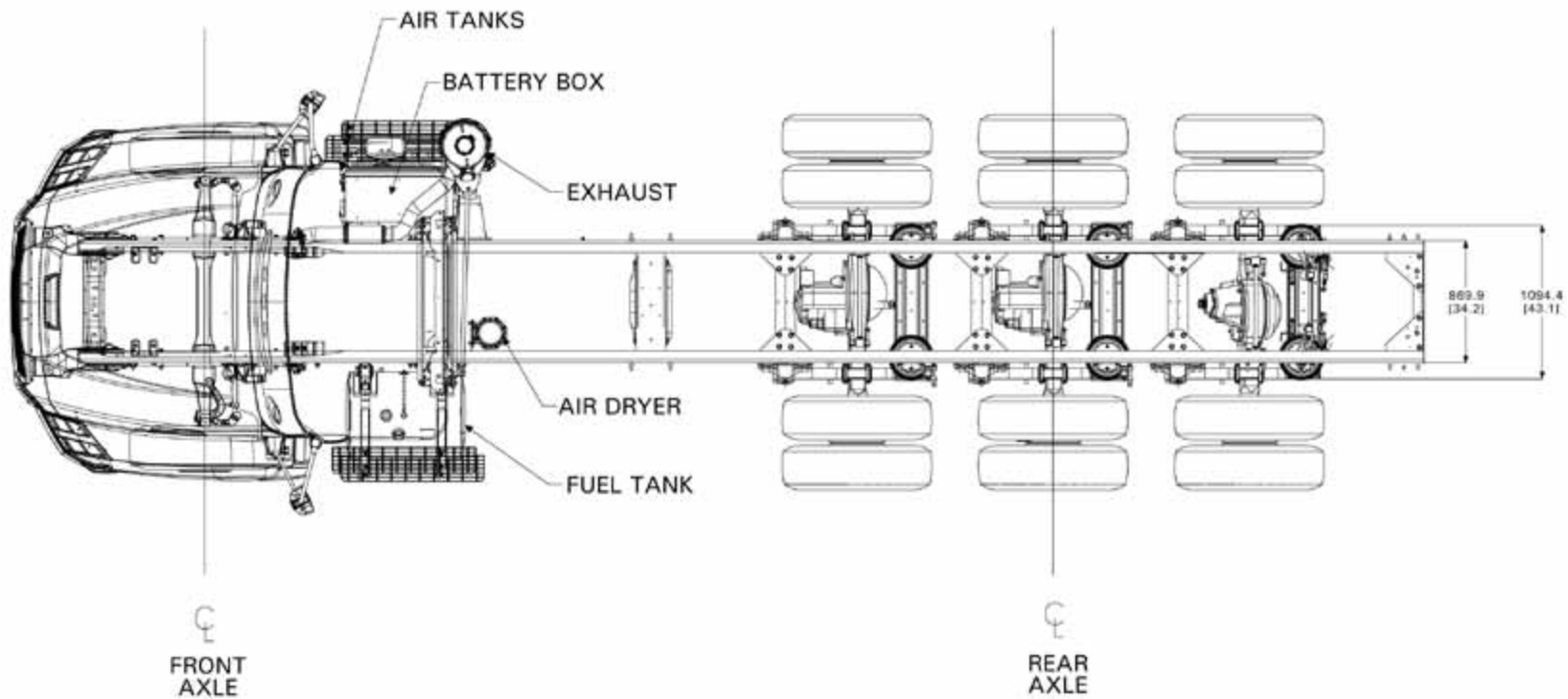

NOTE: This drawing should not be used to determine crossmember location – this information can be found later in the book.

[↶ return to table of contents](#)

CT660 SCR 122BBC 8x6 SPECIFICATIONS

CHASSIS DIAGRAMS — PLAN VIEW (SCR ONLY)

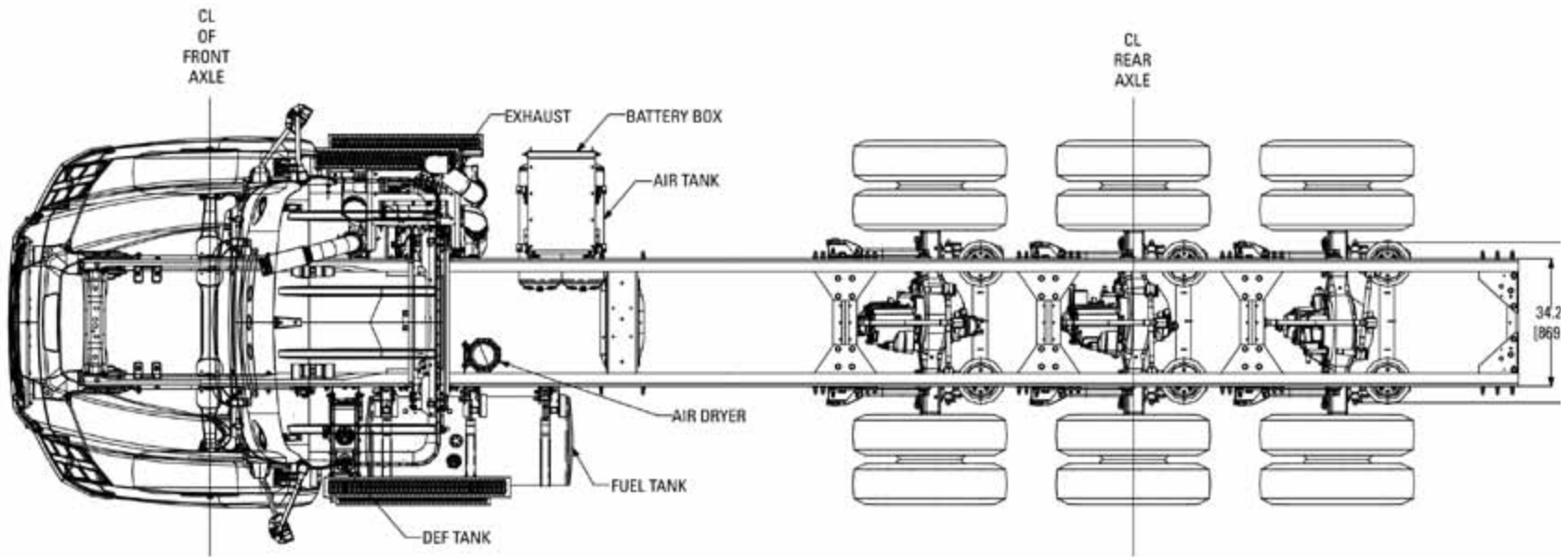

NOTE: This drawing should not be used to determine crossmember location – this information can be found later in the book.

[↶ return to table of contents](#)

CT660 122BBC 8x6 SPECIFICATIONS

CHASSIS DIAGRAMS — SIDE VIEW (EGR ONLY)

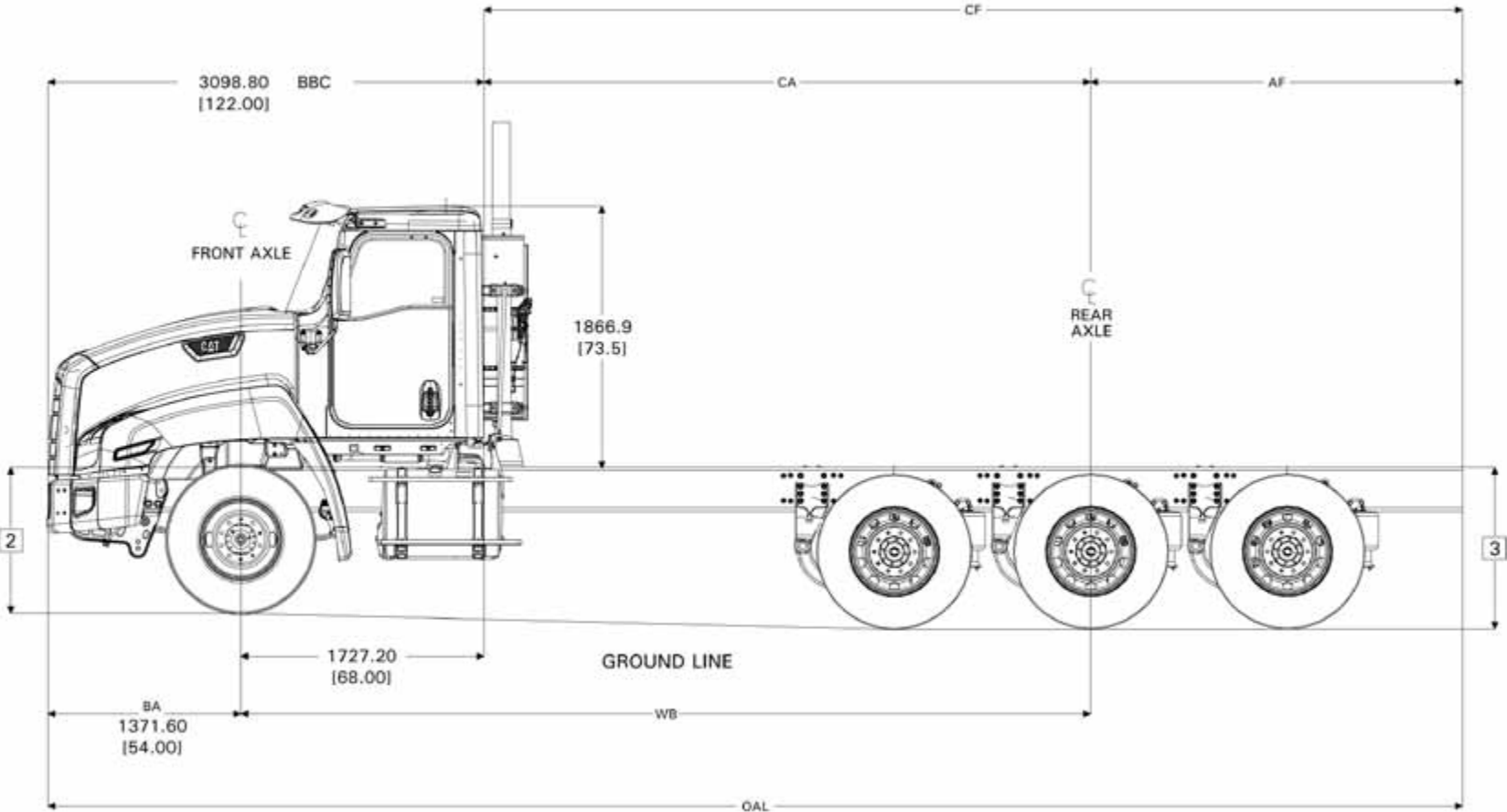

NOTE: This drawing should not be used to determine crossmember location – this information can be found later in the book.

[↶ return to table of contents](#)

CT660 SCR 122BBC 8x6 SPECIFICATIONS

CHASSIS DIAGRAMS — SIDE VIEW (SCR ONLY)

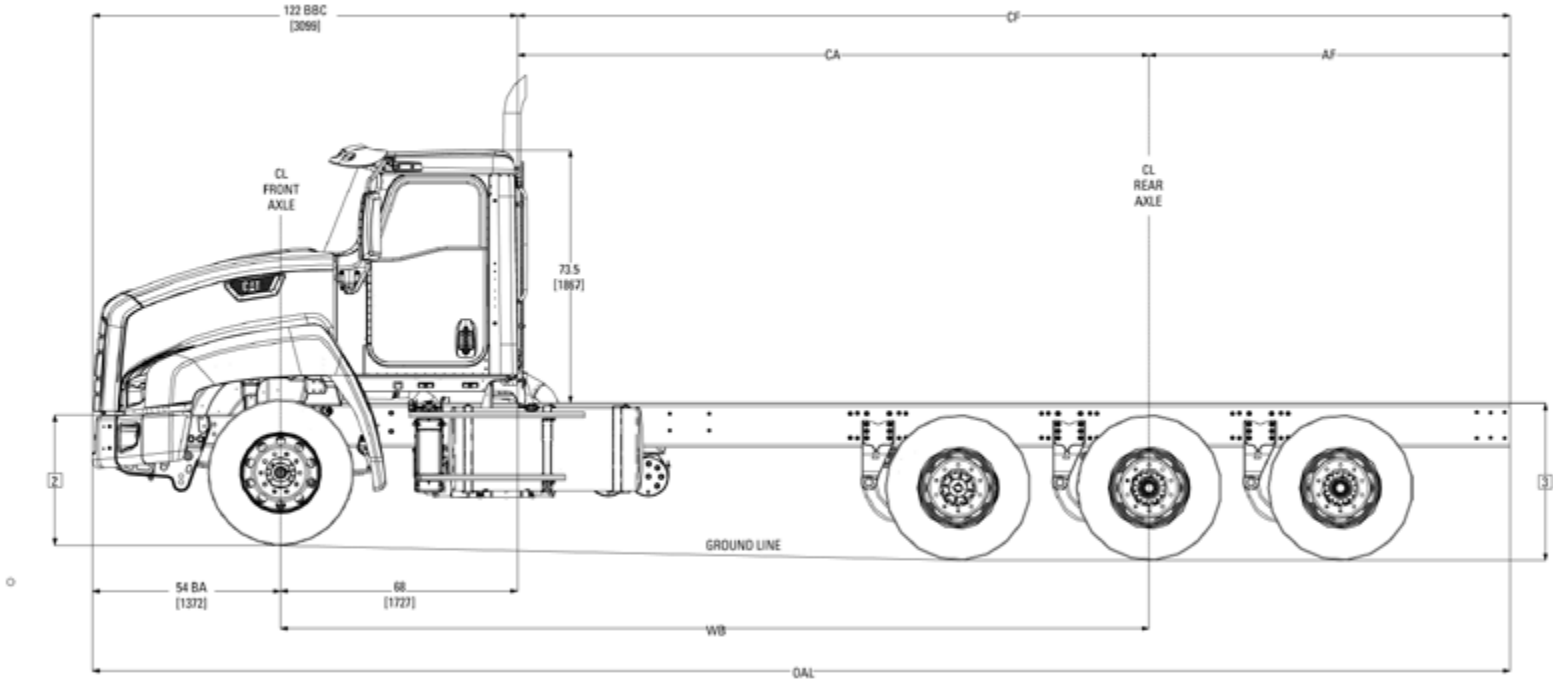

NOTE: This drawing should not be used to determine crossmember location – this information can be found later in the book.

[↶ return to table of contents](#)

CT660 122BBC 4x4 SPECIFICATIONS

WEIGHT/DIMENSIONS/TURNING RADIUS (EGR ONLY)

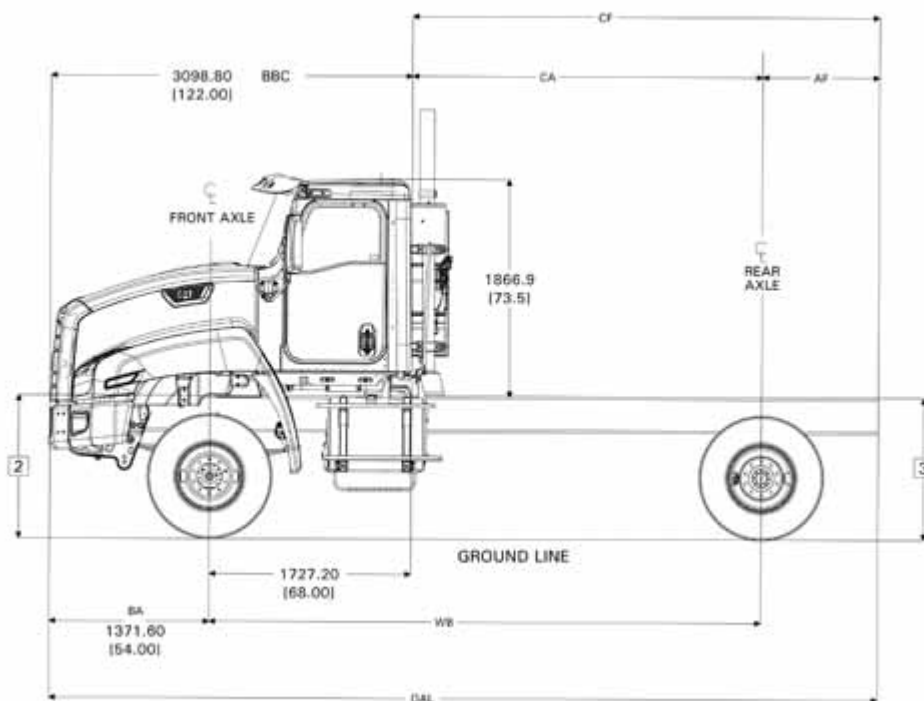

| WHEELBASE (IN.) | CHASSIS WEIGHT (LBS) ** | | | DIMENSIONS (IN.) | | | | TURNING RADIUS | |
|-----------------|-------------------------|-------|--------|------------------|-------|----|-------|----------------|---------------------|
| | FRONT | REAR | TOTAL | CA | CF | AF | OAL | TO CURB | W/ BUMPER CLEARANCE |
| 170 | 9,026 | 4,183 | 13,209 | 101.4 | 154.5 | 39 | 270.6 | 30 ft. 5 in. | 31 ft. 10 in. |
| 188 | | | | 119.1 | 172.2 | 39 | 288.3 | 32 ft. 11 in. | 34 ft. 4 in. |
| 206 | | | | 136.8 | 190 | 39 | 306 | 35 ft. 8 in. | 37 ft. 2 in. |

** Weight includes standard chassis, standard tires, oil and water, but less fuel.

NOTE: This drawing should not be used to determine crossmember location – this information can be found later in the book.

↪ return to table of contents

CT660 122BBC 4x4 SPECIFICATIONS

WEIGHT/DIMENSIONS/TURNING RADIUS (SCR ONLY)

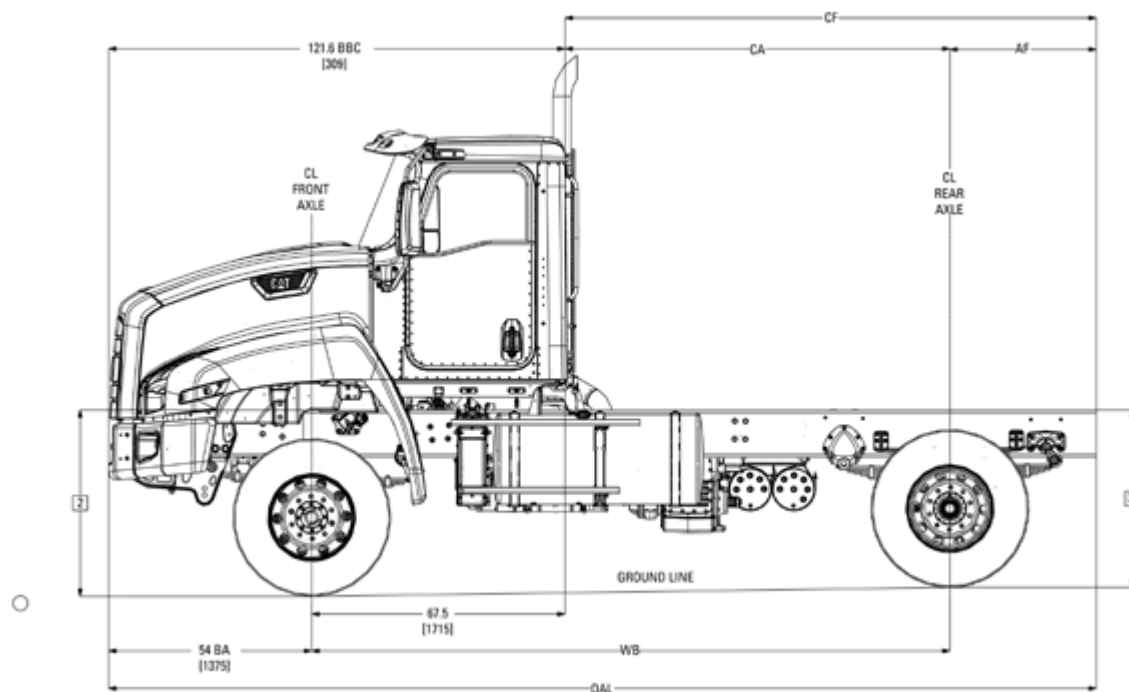

| WHEELBASE (IN.) | CHASSIS WEIGHT (LBS) ** | | | DIMENSIONS (IN.) | | | | TURNING RADIUS | |
|-----------------|-------------------------|-------|--------|------------------|-------|----|-------|----------------|---------------------|
| | FRONT | REAR | TOTAL | CA | CF | AF | OAL | TO CURB | W/ BUMPER CLEARANCE |
| 170 | 11,462 | 5,481 | 16,943 | 101.4 | 154.5 | 39 | 270.6 | 30 ft. 5 in. | 31 ft. 10 in. |
| 188 | | | | 119.1 | 172.2 | 39 | 288.3 | 32 ft. 11 in. | 34 ft. 4 in. |
| 206 | | | | 136.8 | 190 | 39 | 306 | 35 ft. 8 in. | 37 ft. 2 in. |

** Weight includes standard chassis, standard tires, oil and water, but less fuel.

NOTE: This drawing should not be used to determine crossmember location – this information can be found later in the book.

↪ return to table of contents

CT660 122BBC 4x4 SPECIFICATIONS

STANDARD FEATURES

| FEATURE | SPECIFICATION |
|--------------------------------|---|
| FRAME RAILS | FRAME RAILS Heat Treated Alloy Steel (120,000 PSI Yield); 12.250" x 3.380" x 0.375" (304.8mm x 85.6mm x 9.5mm); 543.0" (13793mm) Maximum Frame Length |
| FRONT DRIVING AXLE | Fabco SDA-1800, Single Reduction, 18,000-lb Capacity; With Hub Piloted Wheel Mounting |
| FRONT SPRING SUSPENSION | Multileaf, Shackle Type; 18,000-lb Capacity; Less Shock Absorbers |
| EXHAUST SYSTEM | EGR: Single, Vertical Aftertreatment Device Frame Mounted Right Side; Includes Vertical Tail Pipe & Guard SCR: Switchback Horizontal Aftertreatment Device, Frame Mounted Right Side Under Cab; Includes Single Vertical Tail Pipe, Frame Mounted Right Side Back of Cab |
| ALTERNATOR | ALTERNATOR {Bosch LH160} Brush Type, 12 Volt 160 Amp. Capacity, Pad Mounted |
| BATTERY BOX | Aluminum With Plastic Cover, 18" Wide, Mounted Right Side Back Cab Aluminum With Plastic Cover, 30" Wide, Mounted Right or Left Side Under Cab |
| TRANSFER CASE | Fabco Model 170, Single Speed With Front Axle Declutch, Air Shiftable, Without Neutral, Without PTO Provisions and With Lube Pump |
| SINGLE REAR AXLE | Meritor RS-23-160, Single Reduction 23,000-lb Capacity With 200 Wheel Ends |
| REAR SUSPENSION | SPRING, SINGLE Constant Rate, 23,000-lb Capacity, Includes 4500-lb Capacity Auxiliary |
| FUEL TANK | Non-Polished Aluminum, 24" Diam., 80 U.S. Gal., Mounted Right or Left Side Under Cab |
| FRONT WHEELS | 22.5" Painted Steel, 2 Hand Hole, 10 Stud (285.75MM BC) Hub Piloted, Flanged Nut, Metric Mount, 8.25 DC Rims; With Steel Hubs. |
| REAR WHEELS | 22.5" Painted Steel, 2 Hand Hole, 10- Stud (285.75MM BC) Hub Piloted, Flanged Nut, Metric Mount, 8.25 DC Rims; With Steel Hubs |

CT660 122BBC 4x4 SPECIFICATIONS

CHASSIS DIAGRAMS — PLAN VIEW (EGR ONLY)

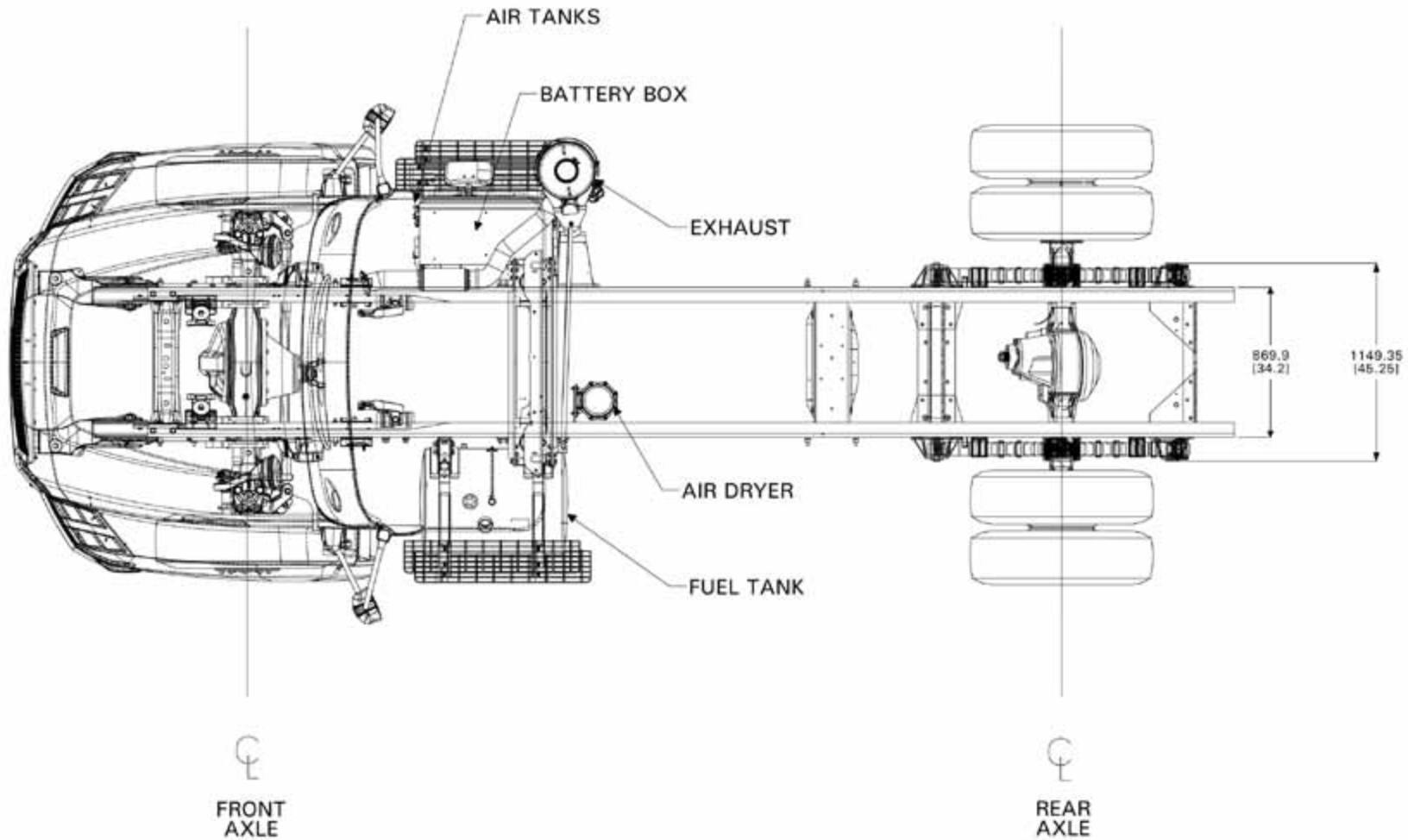

NOTE: This drawing should not be used to determine crossmember location – this information can be found later in the book.

[↶ return to table of contents](#)

CT660 122BBC 4x4 SPECIFICATIONS

CHASSIS DIAGRAMS — PLAN VIEW (SCR ONLY)

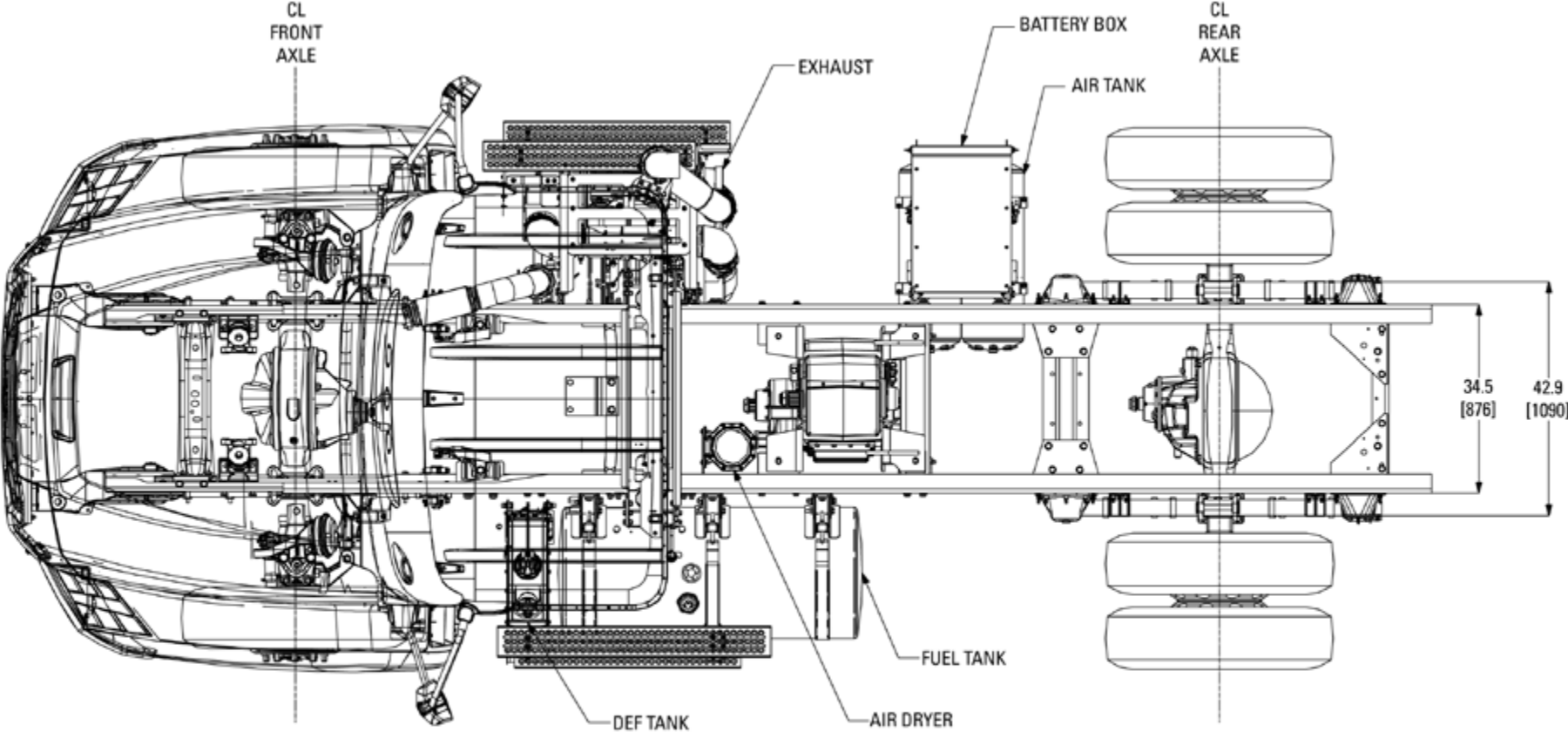

NOTE: This drawing should not be used to determine crossmember location – this information can be found later in the book.

[↶ return to table of contents](#)

CT660 122BBC 4x4 SPECIFICATIONS

CHASSIS DIAGRAMS — SIDE VIEW (EGR ONLY)

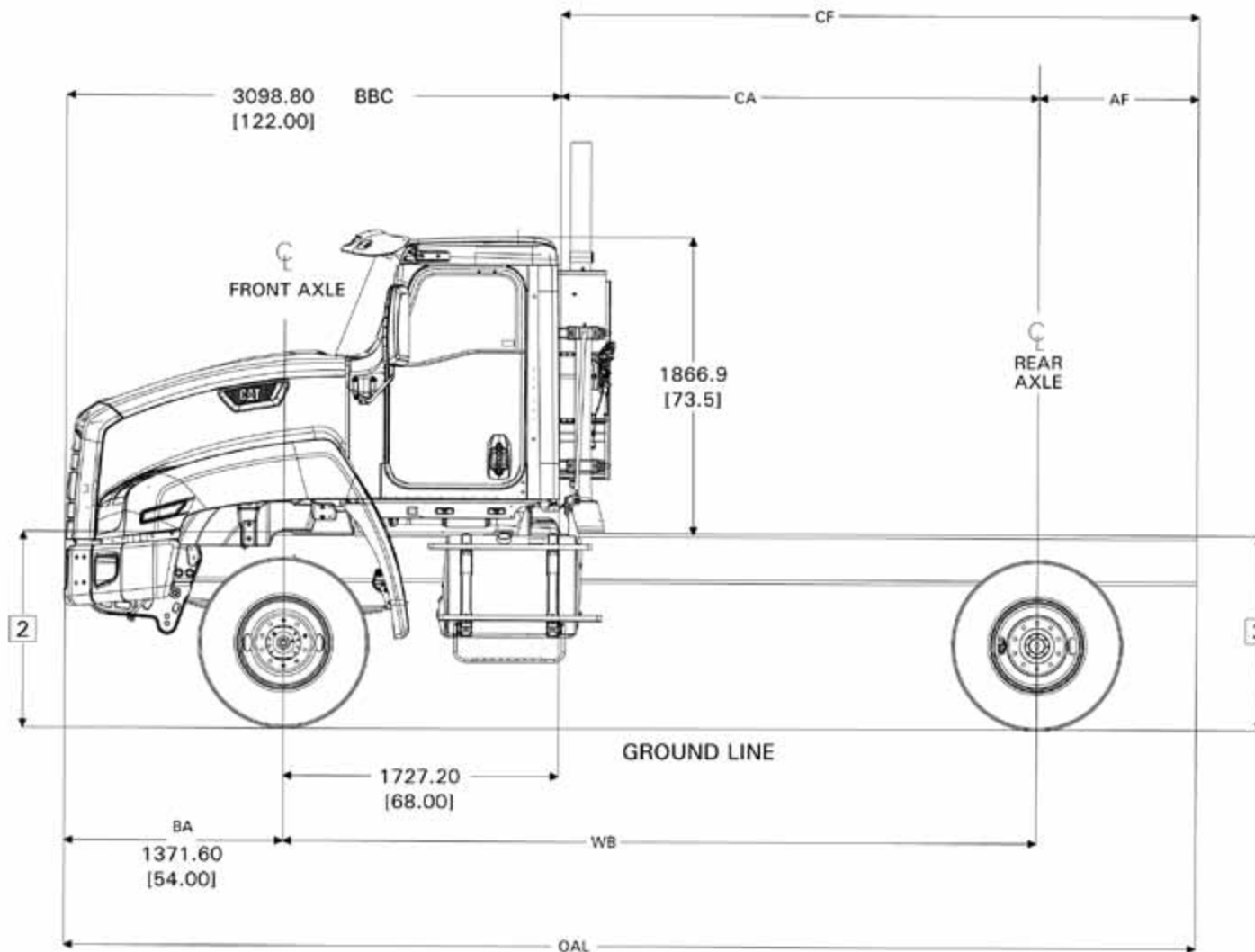

NOTE: This drawing should not be used to determine crossmember location – this information can be found later in the book.

[↶ return to table of contents](#)

CT660 122BBC 4x4 SPECIFICATIONS

CHASSIS DIAGRAMS — SIDE VIEW (SCR ONLY)

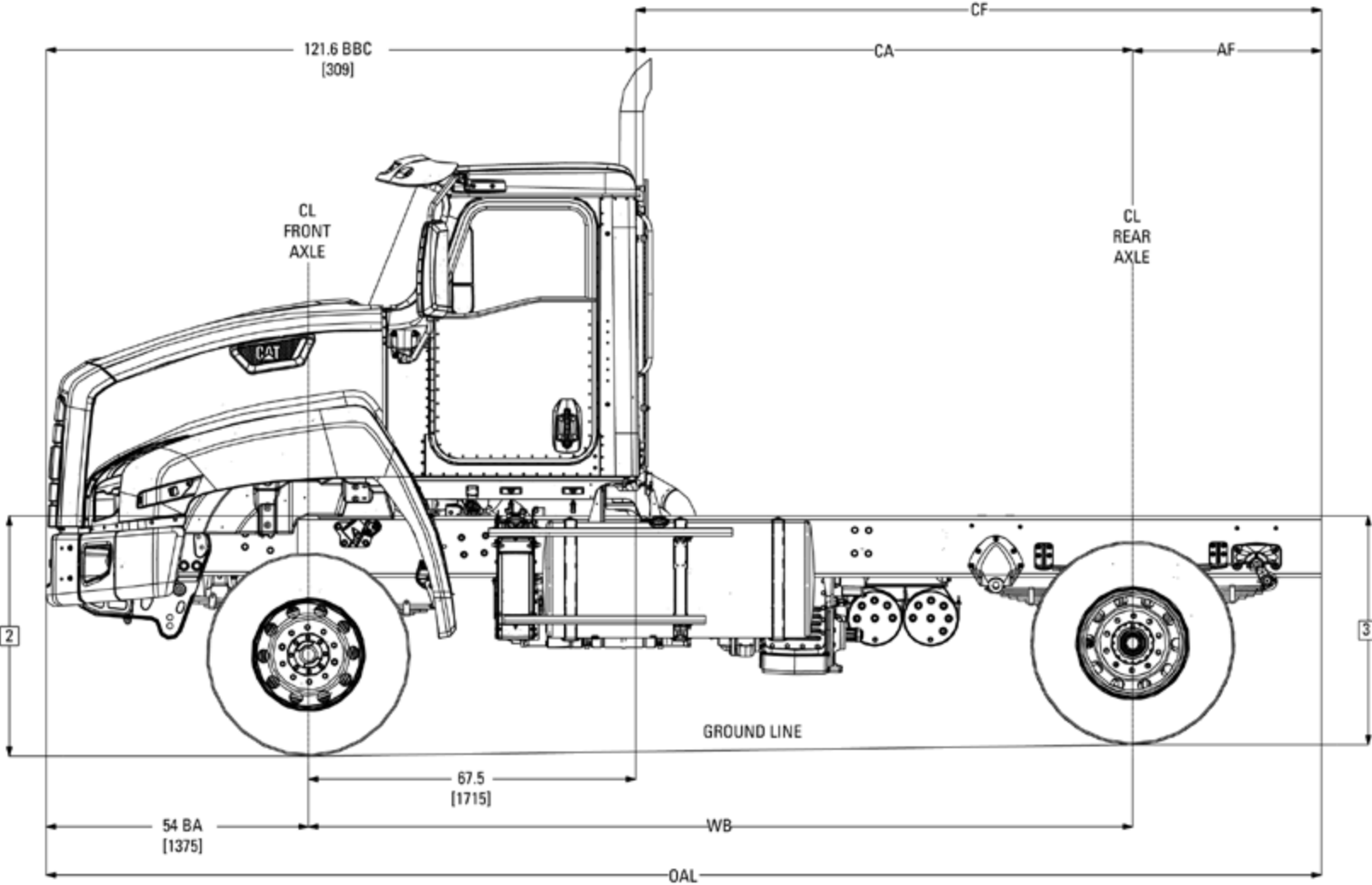

NOTE: This drawing should not be used to determine crossmember location – this information can be found later in the book.

[↶ return to table of contents](#)

CT660 122BBC 6x6 SPECIFICATIONS

WEIGHT/DIMENSIONS/TURNING RADIUS (EGR ONLY)

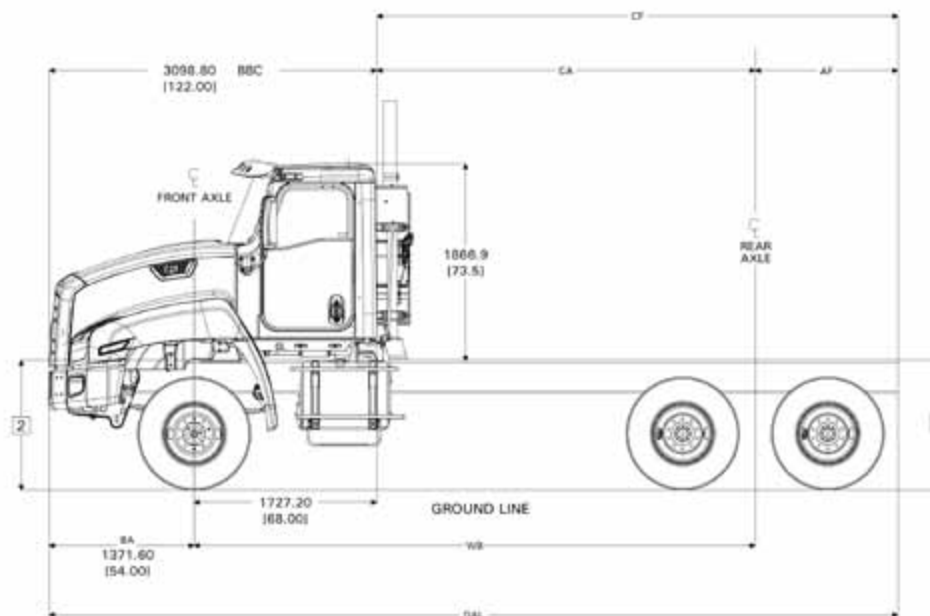

| WHEELBASE (IN.) | CHASSIS WEIGHT (LBS) ** | | | DIMENSIONS (IN.) | | | | TURNING RADIUS | |
|-----------------|-------------------------|-------|--------|------------------|-------|----|-------|----------------|---------------------|
| | FRONT | REAR | TOTAL | CA | CF | AF | OAL | TO CURB | W/ BUMPER CLEARANCE |
| 199 | 10,588 | 7,113 | 17,701 | 130.8 | 184 | 53 | 306 | 34 ft. 7 in. | 36 ft. 1 in. |
| 211 | | | | 142.6 | 195.8 | 53 | 317.8 | 36 ft. 6 in. | 37 ft. 11 in. |

** Weight includes standard chassis, standard tires, oil and water, but less fuel.

NOTE: This drawing should not be used to determine crossmember location – this information can be found later in the book.

[↶ return to table of contents](#)

CT660 122BBC 6x6 SPECIFICATIONS

WEIGHT/DIMENSIONS/TURNING RADIUS (SCR ONLY)

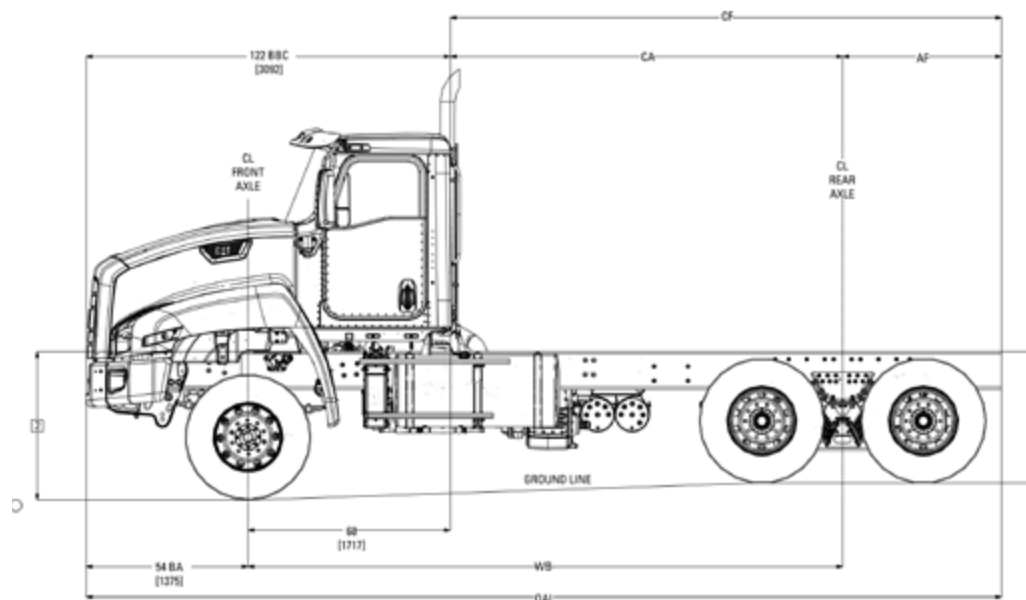

| WHEELBASE (IN.) | CHASSIS WEIGHT (LBS) ** | | | DIMENSIONS (IN.) | | | | TURNING RADIUS | |
|-----------------|-------------------------|-------|--------|------------------|-------|----|-------|----------------|---------------------|
| | FRONT | REAR | TOTAL | CA | CF | AF | OAL | TO CURB | W/ BUMPER CLEARANCE |
| 199 | 11,520 | 7,252 | 18,772 | 130.8 | 184 | 53 | 306 | 34 ft. 7 in. | 36 ft. 1 in. |
| 211 | | | | 142.6 | 195.8 | 53 | 317.8 | 36 ft. 6 in. | 37 ft. 11 in. |

** Weight includes standard chassis, standard tires, oil and water, but less fuel.

NOTE: This drawing should not be used to determine crossmember location – this information can be found later in the book.

[↶ return to table of contents](#)

CT660 122BBC 6x6 SPECIFICATIONS

STANDARD FEATURES

| FEATURE | SPECIFICATION |
|------------------------------------|---|
| FRAME RAILS | FRAME RAILS Heat Treated Alloy Steel (120,000 PSI Yield); 12.250" x 3.380" x 0.375" (304.8mm x 85.6mm x 9.5mm); 543.0" (13793mm) Maximum Frame Length |
| FRONT DRIVING AXLE | Fabco SDA-1800, Single Reduction, 18,000-lb Capacity; With Hub Piloted Wheel Mounting |
| FRONT SPRING SUSPENSION | Multileaf, Shackle Type; 18,000-lb Capacity; Less Shock Absorbers |
| EXHAUST SYSTEM | EGR: Single, Vertical Aftertreatment Device Frame Mounted Right Side; Includes Vertical Tail Pipe & Guard SCR: Switchback Horizontal Aftertreatment Device, Frame Mounted Right Side Under Cab; Includes Single Vertical Tail Pipe, Frame Mounted Right Side Back of Cab |
| ALTERNATOR | Bosch LH160, 12 Volt 160 Amp. Capacity, Pad Mounted |
| BATTERY BOX | Aluminum With Plastic Cover, 18" Wide, Mounted Right Side Back Cab Aluminum With Plastic Cover, 30" Wide, Mounted Right or Left Side Under Cab |
| TRANSFER CASE | Fabco Model 180, Single Speed With Front Axle Declutch, Air Shiftable, Without Neutral, Without PTO Provisions and With Lube Pump |
| TANDEM REAR AXLE | Meritor MT-40-14X-4DFR-P, Single Reduction, 0.433" (11mm) Wall Housing Thickness, 40,000-lb Capacity, R Wheel Ends, With Lube Oil Pump Capacity, "R" Wheel Ends, With Lube Oil Pump |
| REAR AIR SUSPENSION, TANDEM | Hendrickson HMX-400-54, Walking Beam Type 54" Axle Spacing; 40,000-lb Capacity, With Rubber End Bushings, Transverse Torque Rods, Less Shock Absorbers |
| FUEL TANK | Non-Polished Aluminum, 24" Diam., 80 U.S. Gal., Mounted Right or Left Side Under Cab |
| FRONT WHEELS | 22.5" Painted Steel, 2 Hand Hole, 10 Stud (285.75MM BC) Hub Piloted, Flanged Nut, Metric Mount, 8.25 DC Rims; With Steel Hubs. |
| REAR WHEELS | 22.5" Painted Steel, 2 Hand Hole, 10-Stub (285.75MM BC) Hub Piloted, Flanged Nut, Metric Mount, 8.25 DC Rims; With Steel Hubs |

[↶ return to table of contents](#)

CT660 122BBC 6x6 SPECIFICATIONS

CHASSIS DIAGRAMS — PLAN VIEW (EGR ONLY)

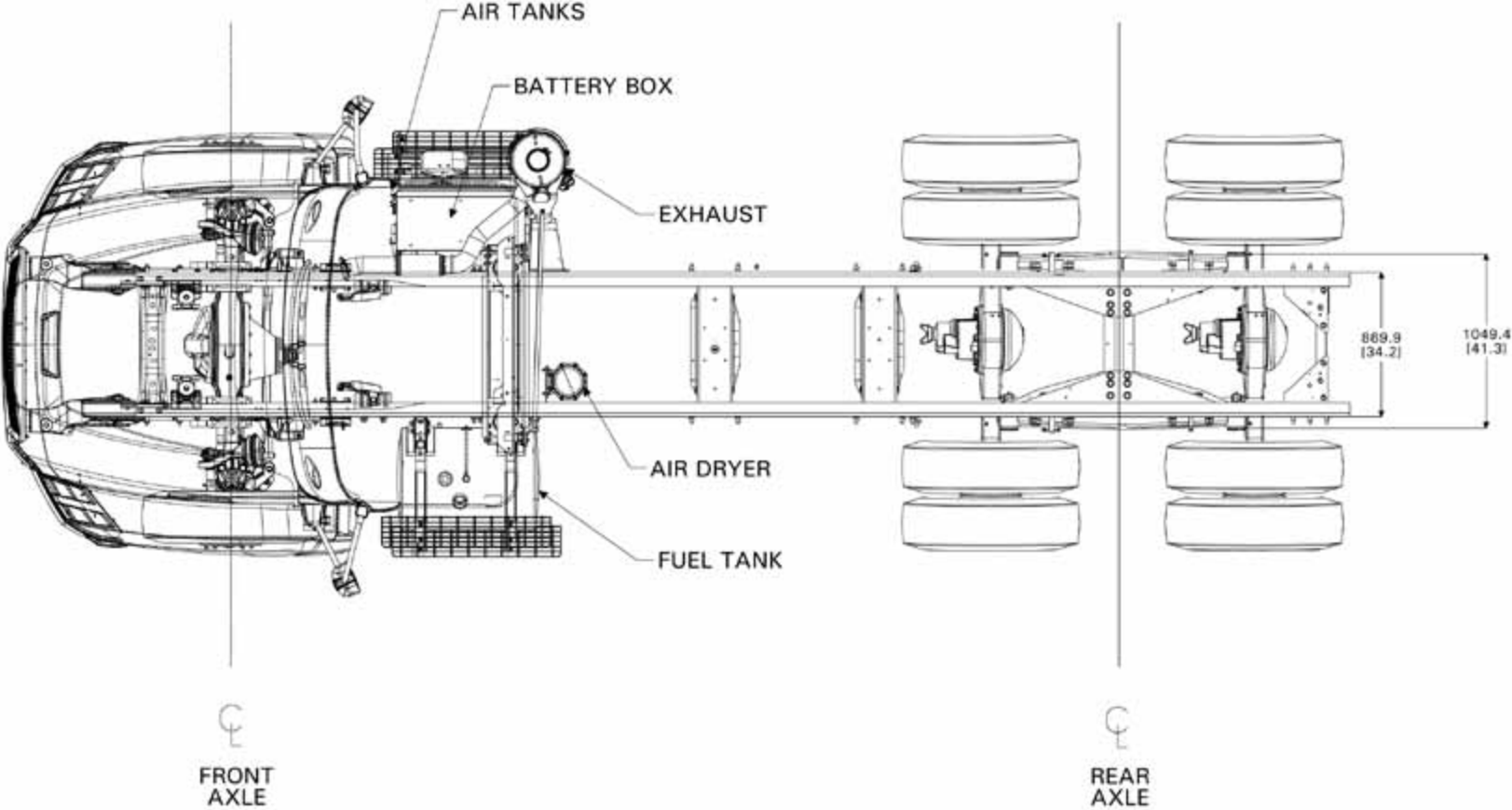

NOTE: This drawing should not be used to determine crossmember location – this information can be found later in the book.

[↶ return to table of contents](#)

CT660 122BBC 6x6 SPECIFICATIONS

CHASSIS DIAGRAMS — PLAN VIEW (SCR ONLY)

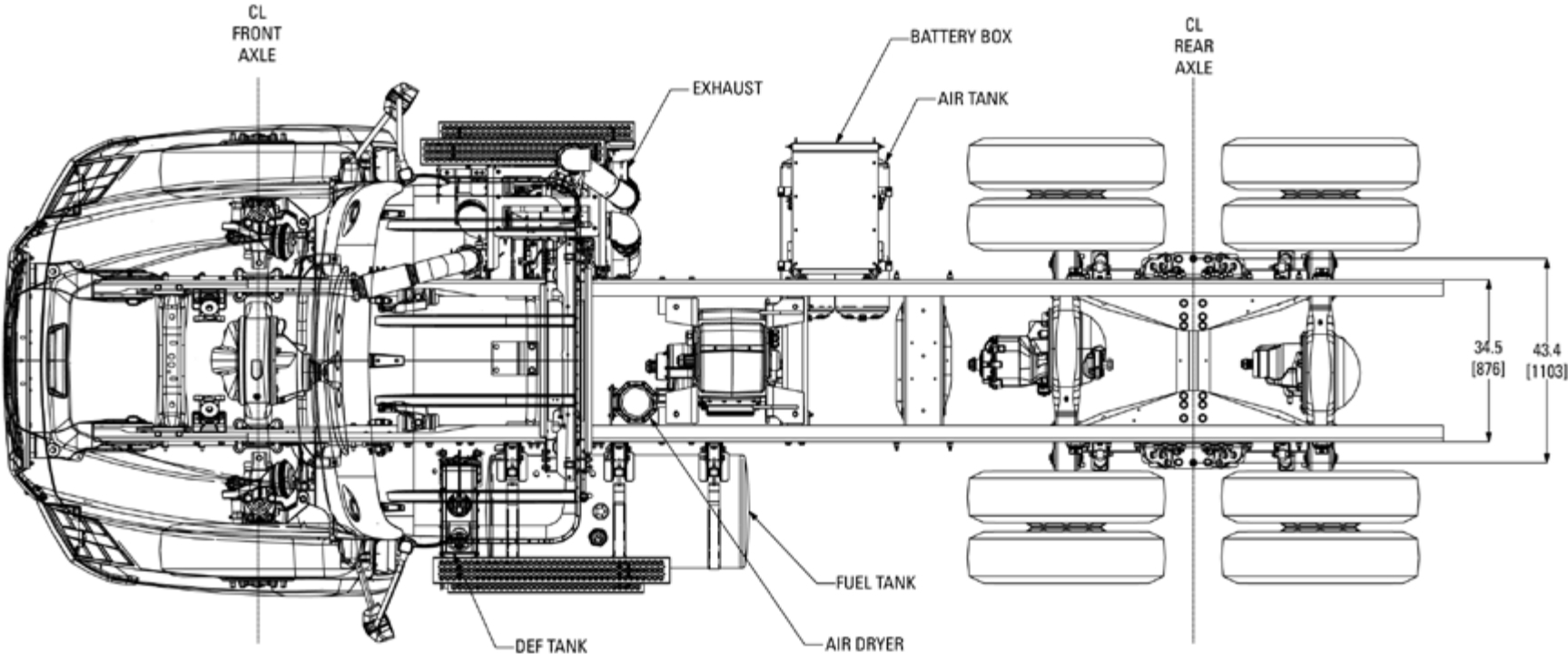

NOTE: This drawing should not be used to determine crossmember location – this information can be found later in the book.

[↶ return to table of contents](#)

CT660 122BBC 6x6 SPECIFICATIONS

CHASSIS DIAGRAMS — SIDE VIEW (EGR ONLY)

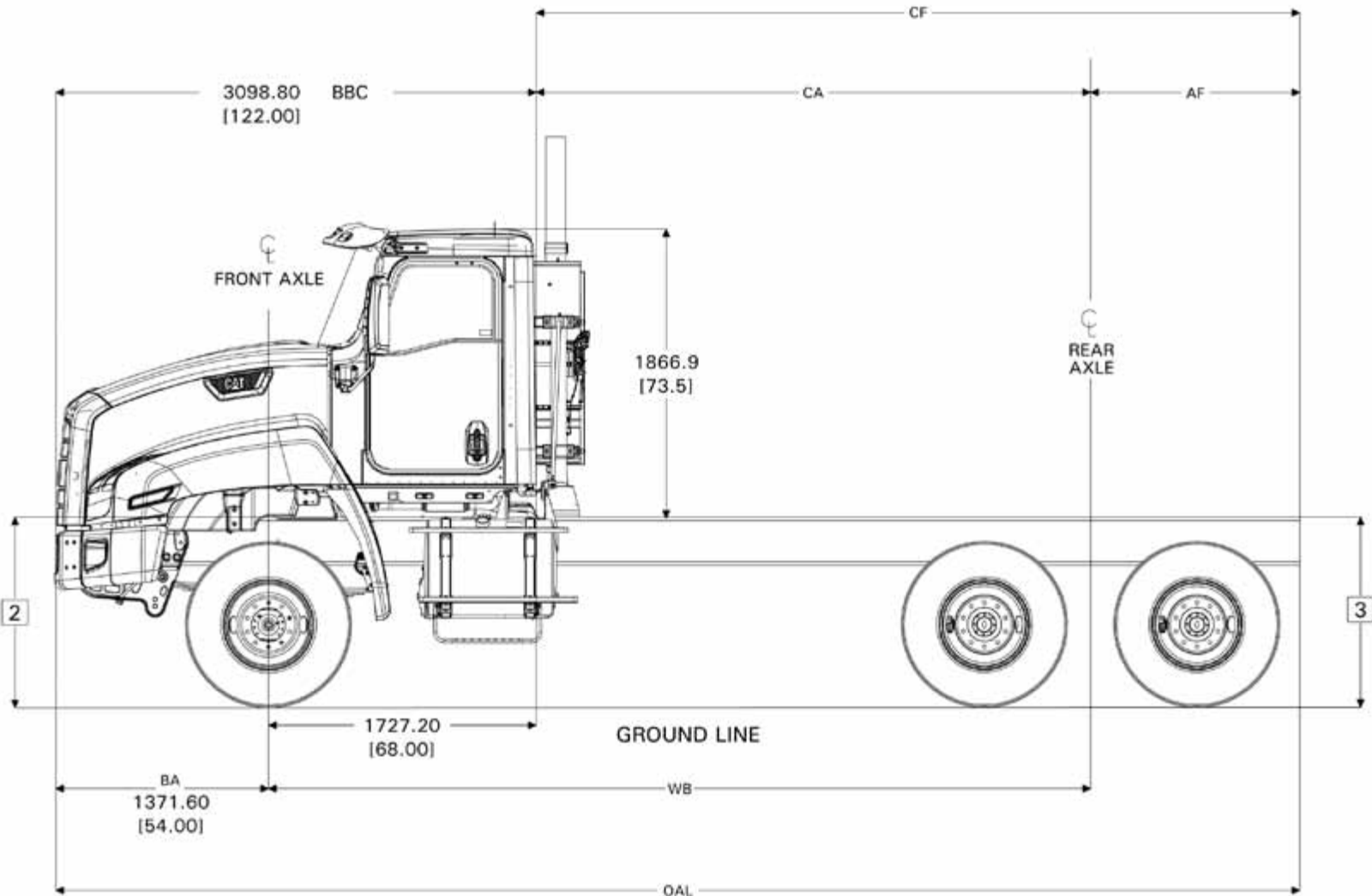

NOTE: This drawing should not be used to determine crossmember location – this information can be found later in the book.

[↶ return to table of contents](#)

CT660 122BBC 6x6 SPECIFICATIONS

CHASSIS DIAGRAMS — SIDE VIEW (SCR ONLY)

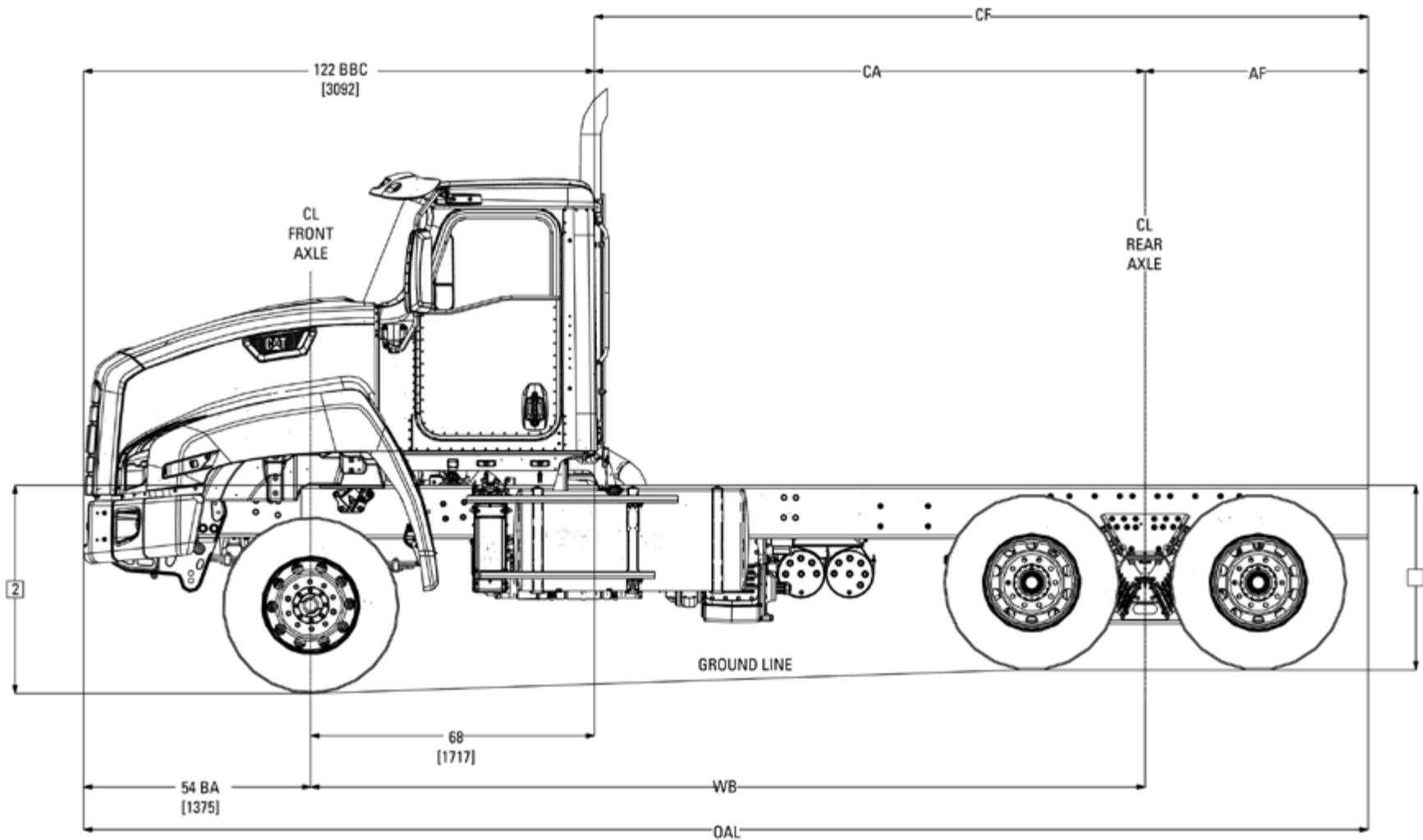

NOTE: This drawing should not be used to determine crossmember location – this information can be found later in the book.

[↶ return to table of contents](#)

ALL MODEL SPECIFICATIONS

CHASSIS DIAGRAMS — 6X4 & 8X6 — FRONT VIEW

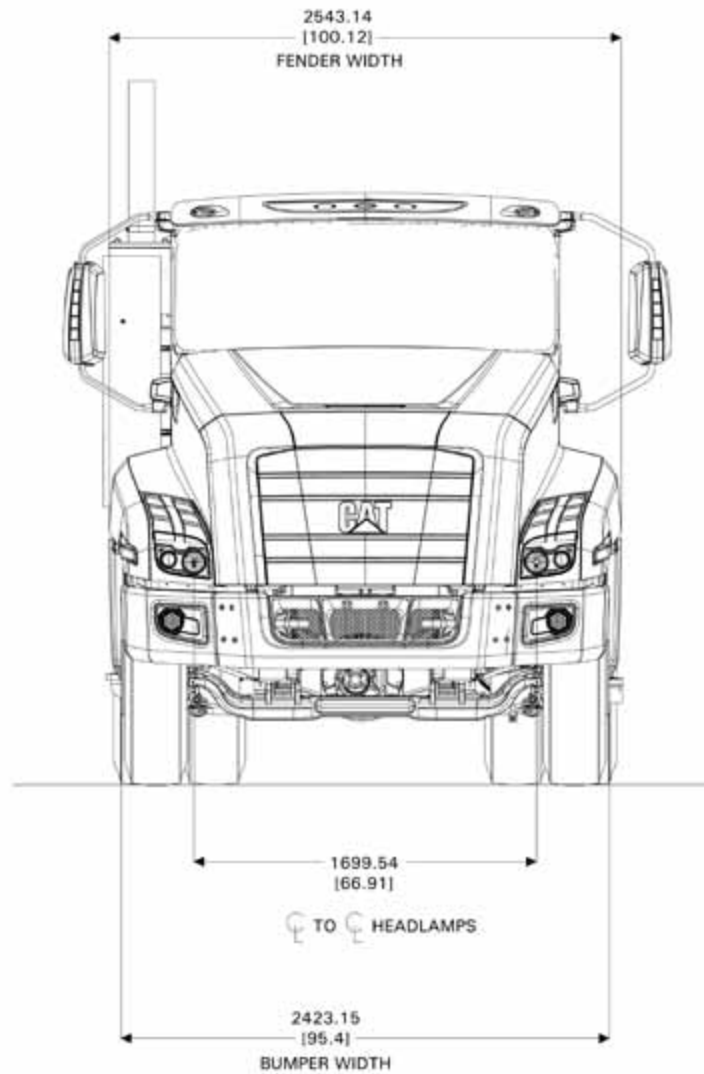

NOTE: This drawing should not be used to determine crossmember location – this information can be found later in the book.

[↶ return to table of contents](#)

ALL MODEL SPECIFICATIONS

CHASSIS DIAGRAMS — 4X4 & 6X6 — FRONT VIEW

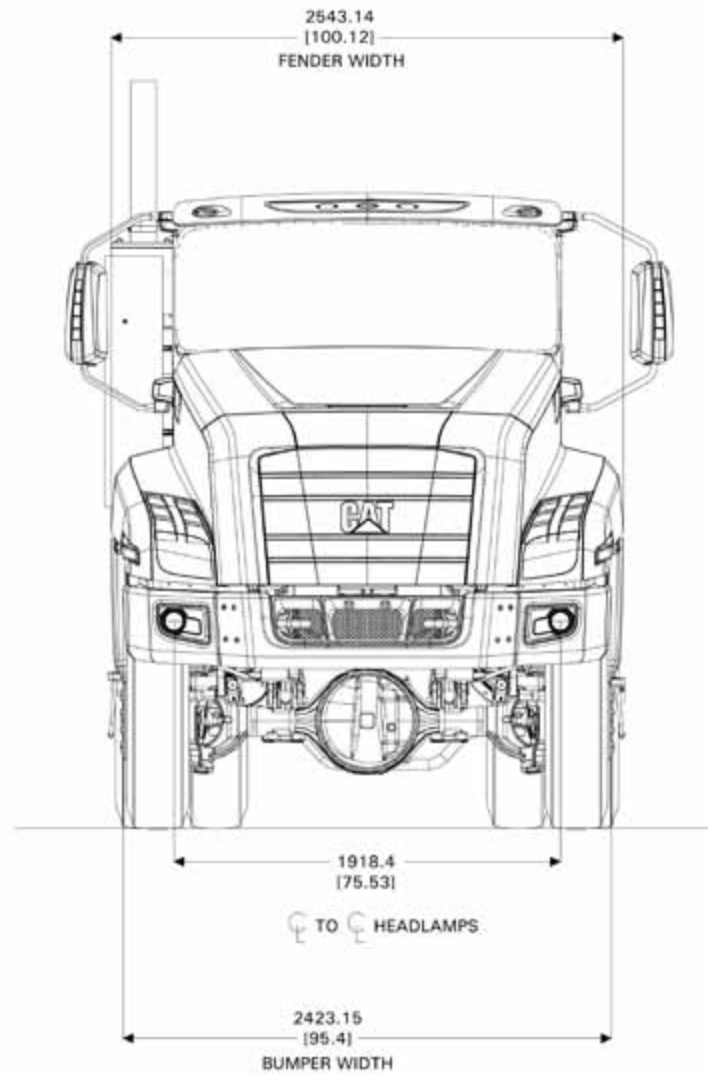

NOTE: This drawing should not be used to determine crossmember location – this information can be found later in the book.

[↶ return to table of contents](#)

CT660 116BBC 6x4 SPECIFICATIONS

CHASSIS DIAGRAMS – FRONT VIEW (SCR ONLY)

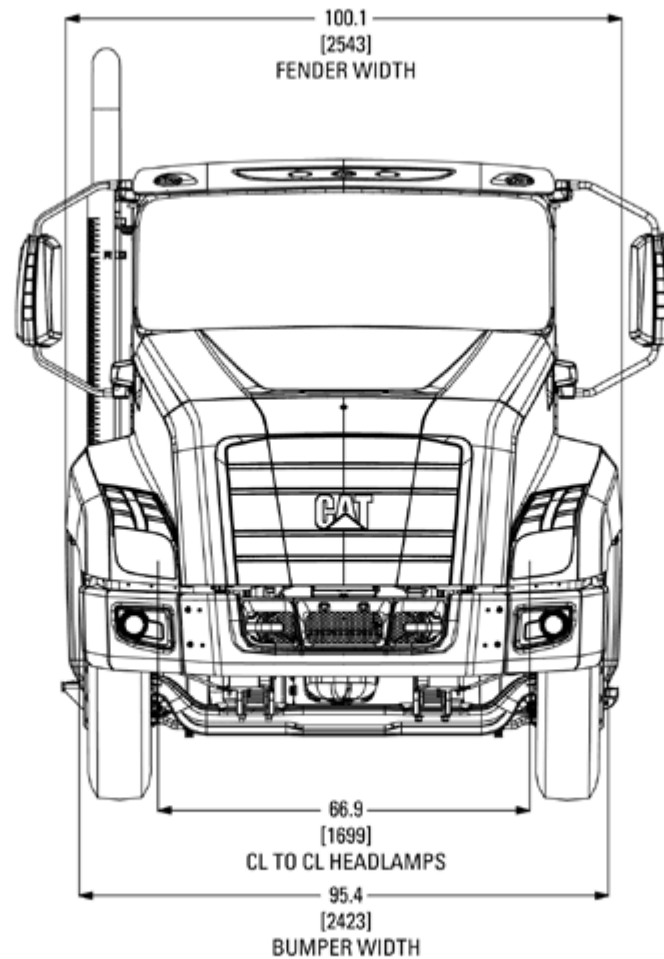

CT660 116BBC 8x6 SPECIFICATIONS

CHASSIS DIAGRAMS – FRONT VIEW (SCR ONLY)

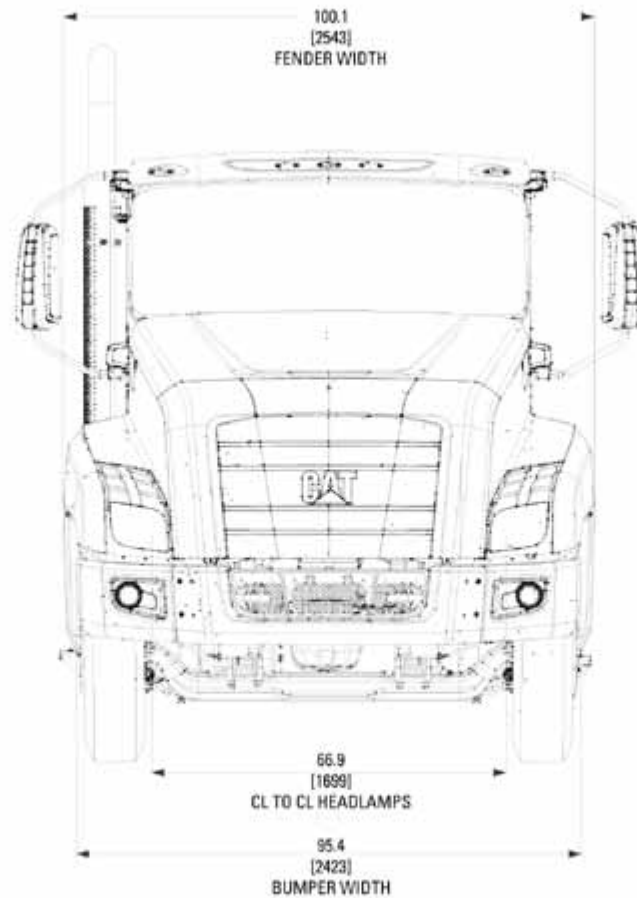

CT660 122BBC 6x4 SPECIFICATIONS

CHASSIS DIAGRAMS – FRONT VIEW (SCR ONLY)

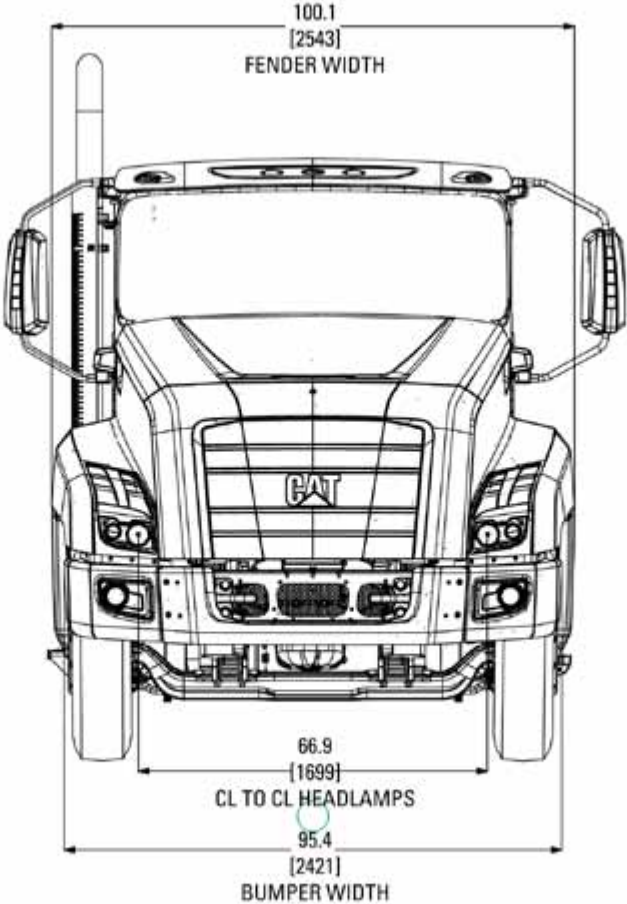

CT660 122BBC 8x6 SPECIFICATIONS

CHASSIS DIAGRAMS – FRONT VIEW (SCR ONLY)

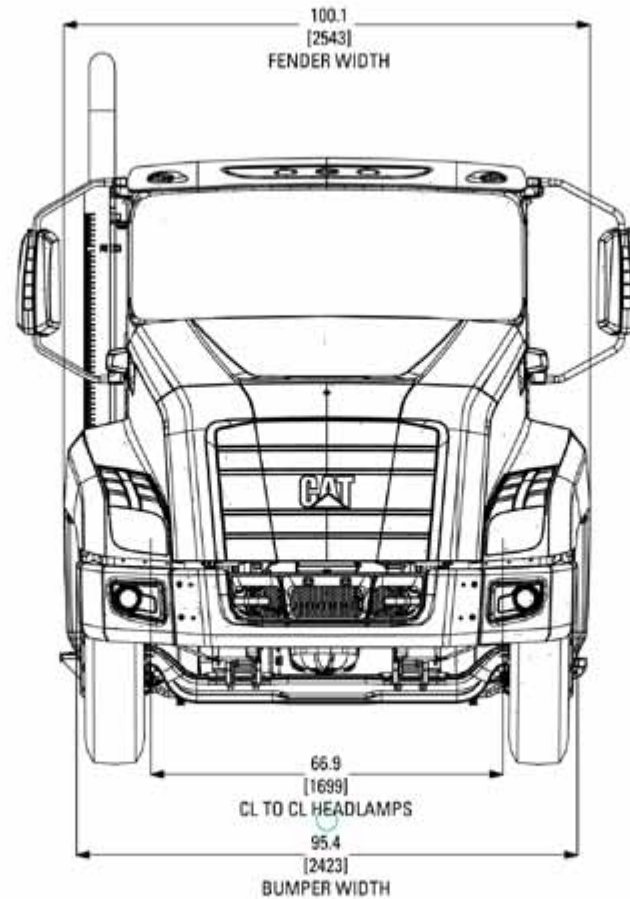

[↶ return to table of contents](#)

ALL MODEL SPECIFICATIONS

CHASSIS DIAGRAMS — 6X4 & 8X6 — REAR VIEW (EGR ONLY)

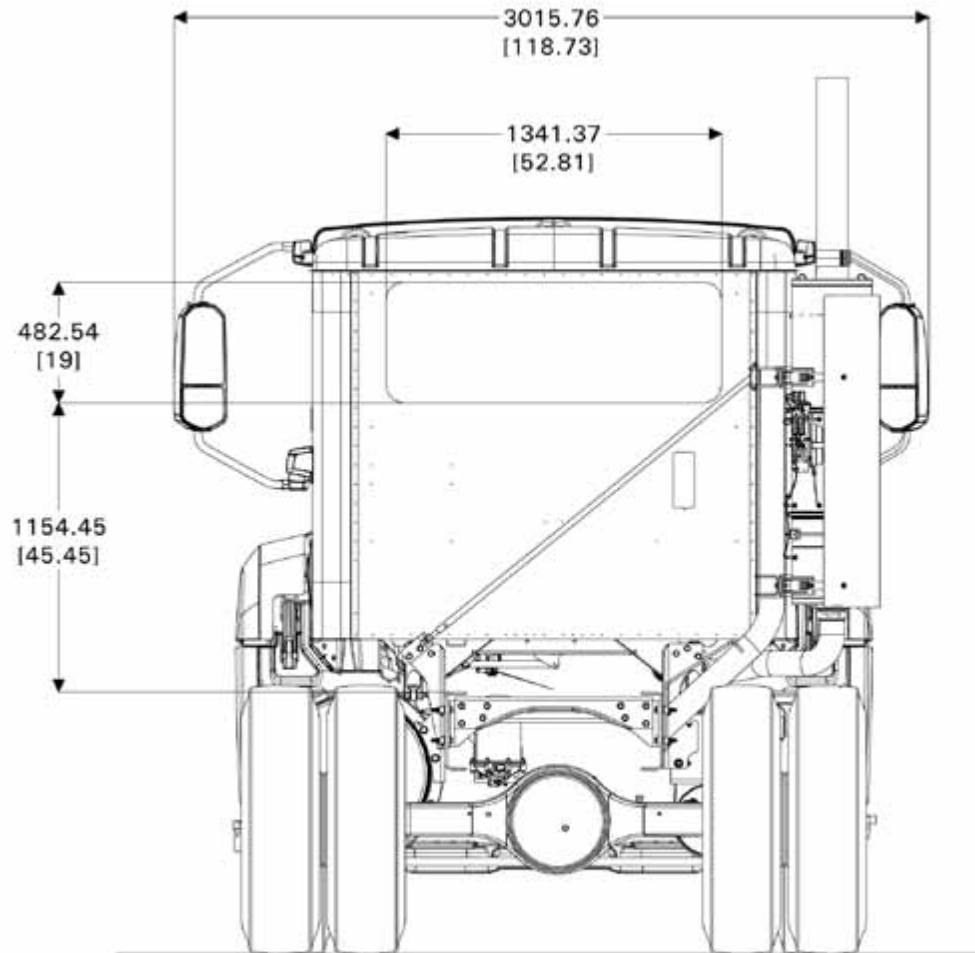

NOTE: This drawing should not be used to determine crossmember location – this information can be found later in the book.

[↶ return to table of contents](#)

ALL MODEL SPECIFICATIONS

CHASSIS DIAGRAMS — 4X4 & 6X6 — REAR VIEW (EGR ONLY)

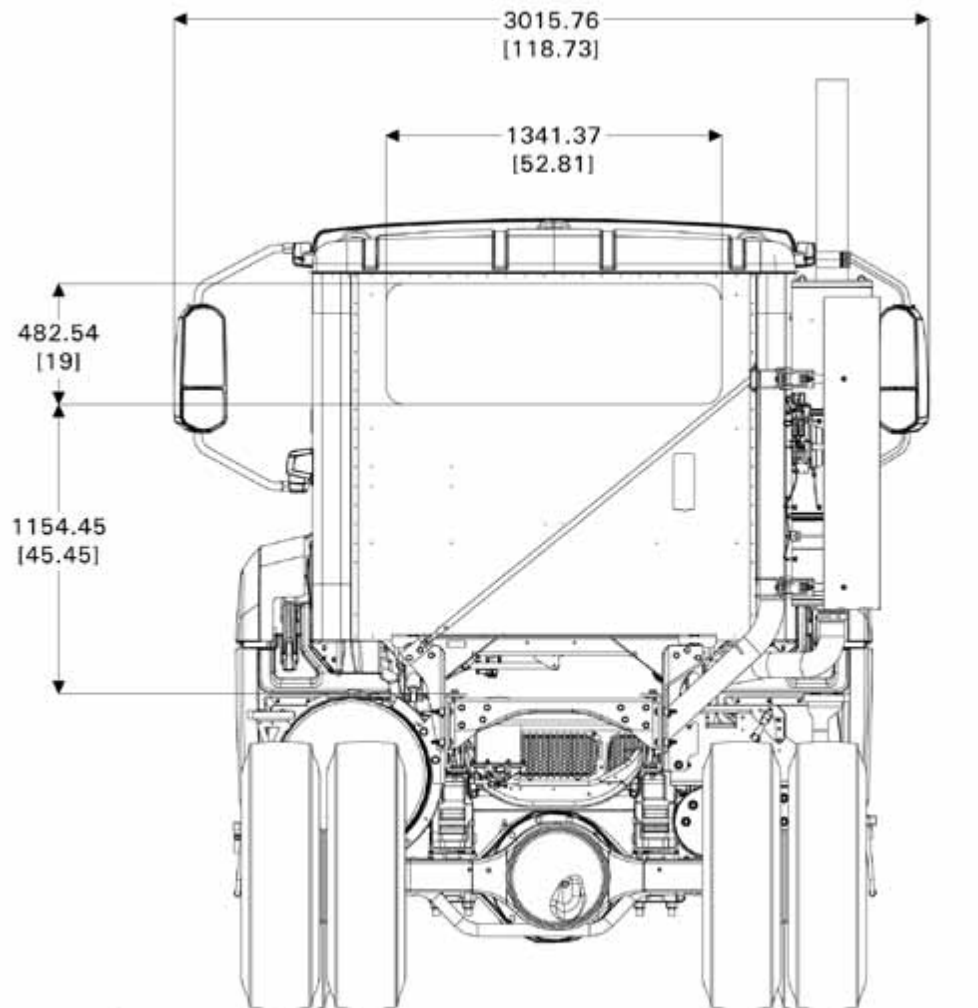

NOTE: This drawing should not be used to determine crossmember location – this information can be found later in the book.

[↶ return to table of contents](#)

CT660 122BBC 6x6 SPECIFICATIONS

CHASSIS DIAGRAMS – REAR VIEW (SCR ONLY)

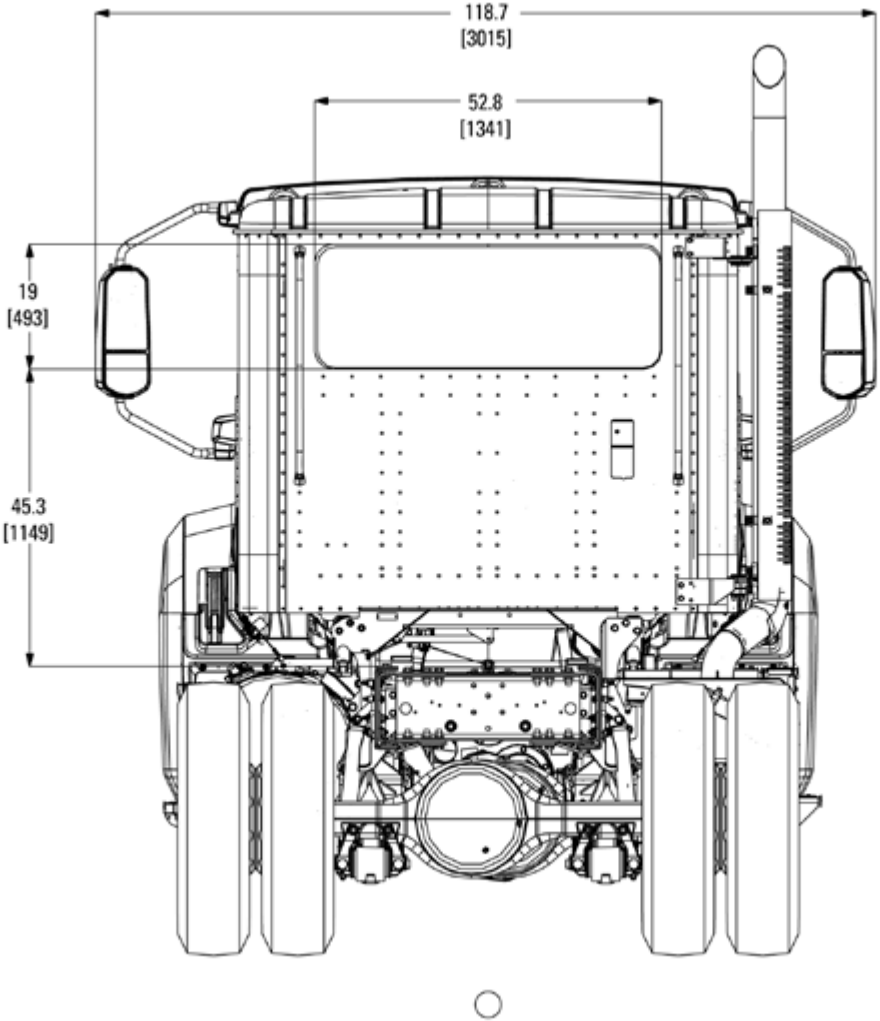

CT660 116BBC 6x4 SPECIFICATIONS

CHASSIS DIAGRAMS – REAR VIEW (SCR ONLY)

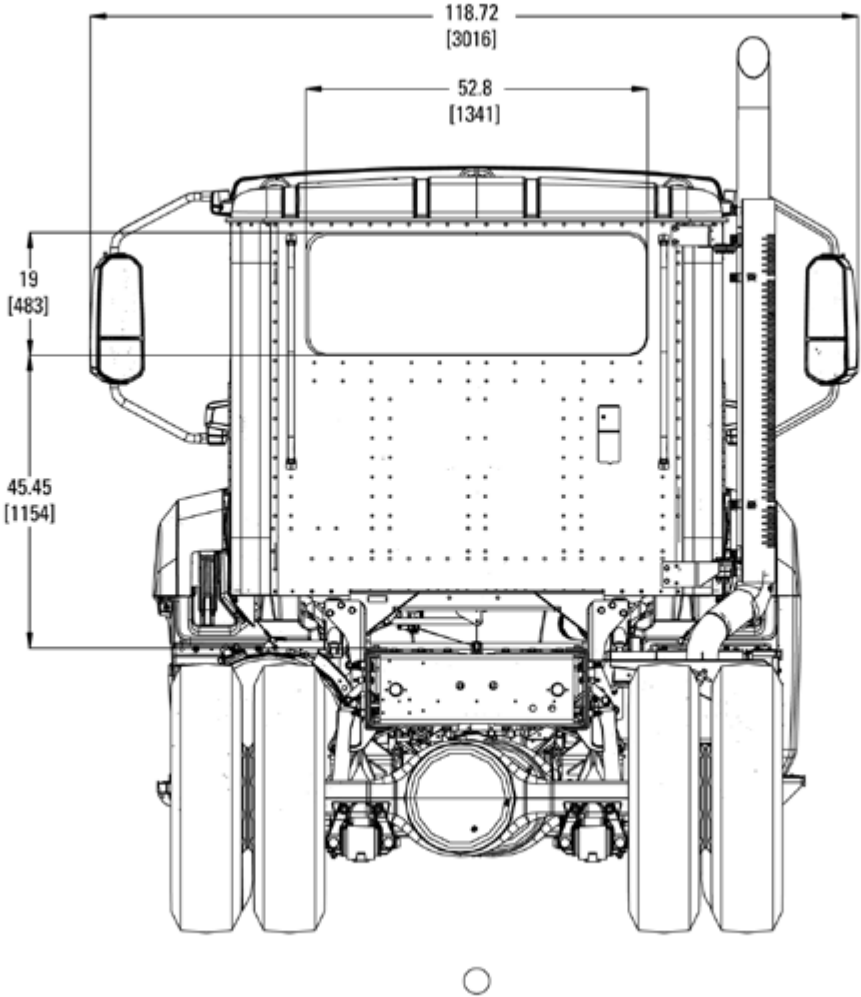

CT660 116BBC 8x6 SPECIFICATIONS

CHASSIS DIAGRAMS – REAR VIEW (SCR ONLY)

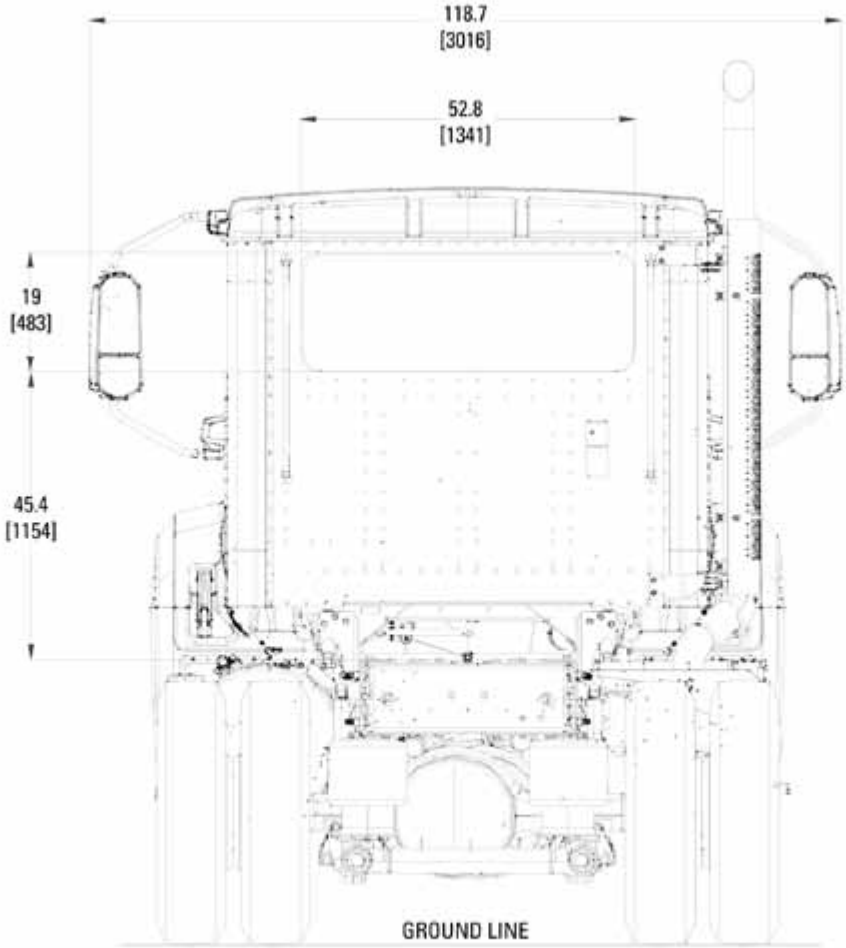

CT660 122BBC 6x4 SPECIFICATIONS

CHASSIS DIAGRAMS – REAR VIEW (SCR ONLY)

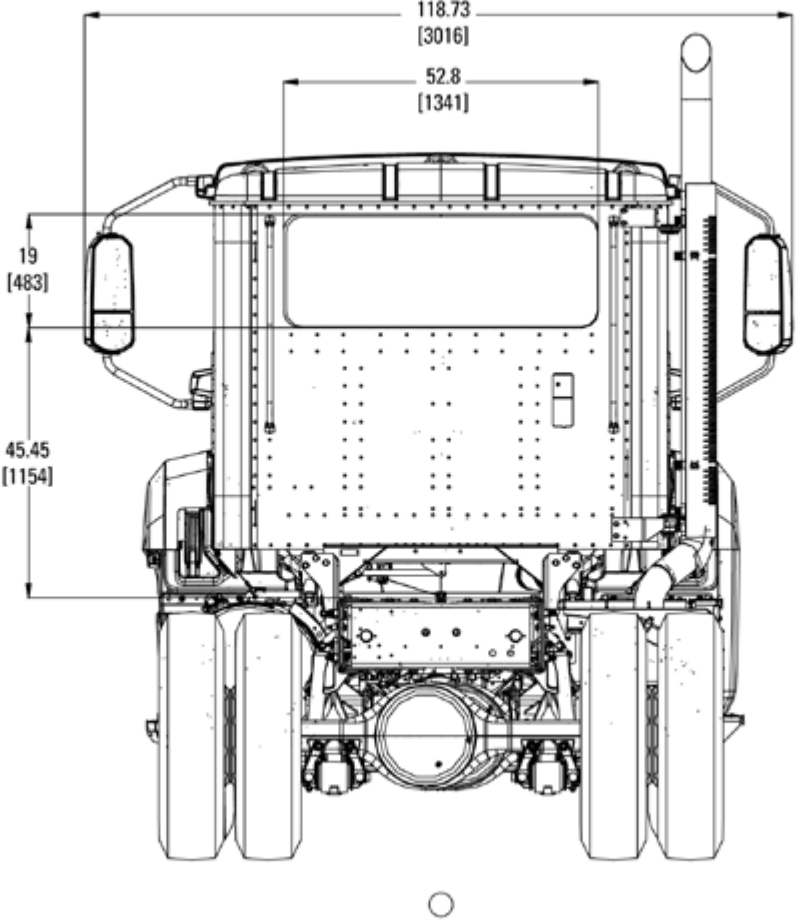

CT660 122BBC 8x6 SPECIFICATIONS

CHASSIS DIAGRAMS – REAR VIEW (SCR ONLY)

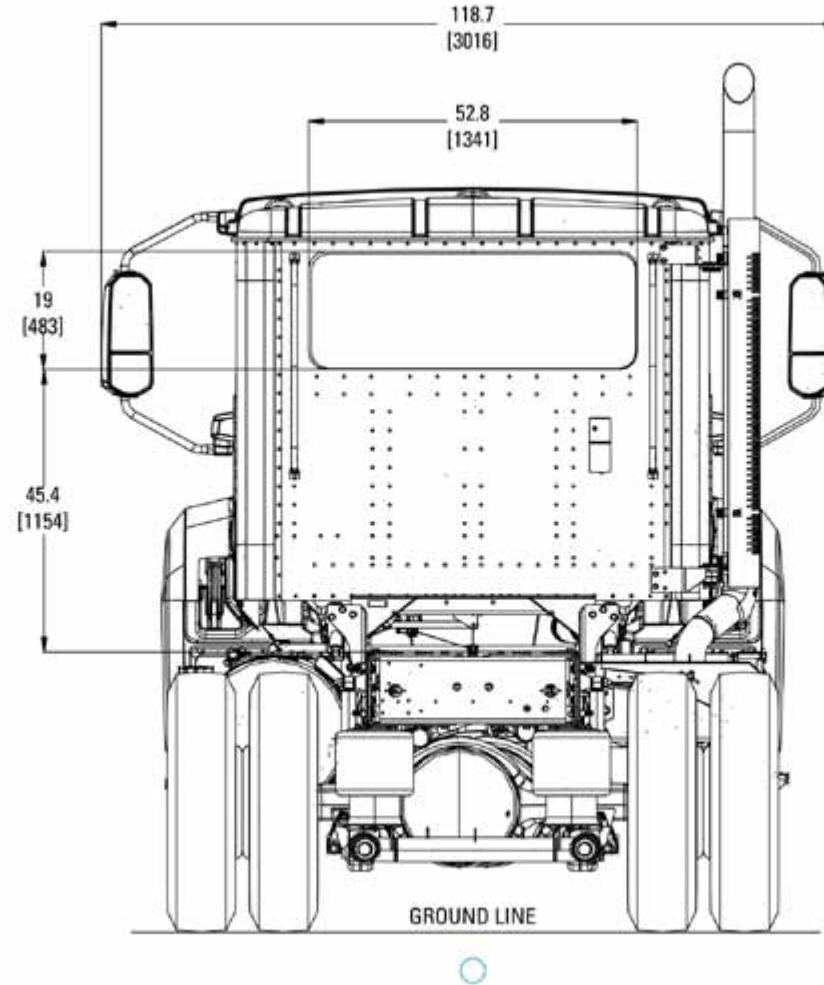

ALL MODEL SPECIFICATIONS

CT11/13 CHASSIS DIAGRAMS – HOOD TILT — SIDE VIEW (EGR ONLY)

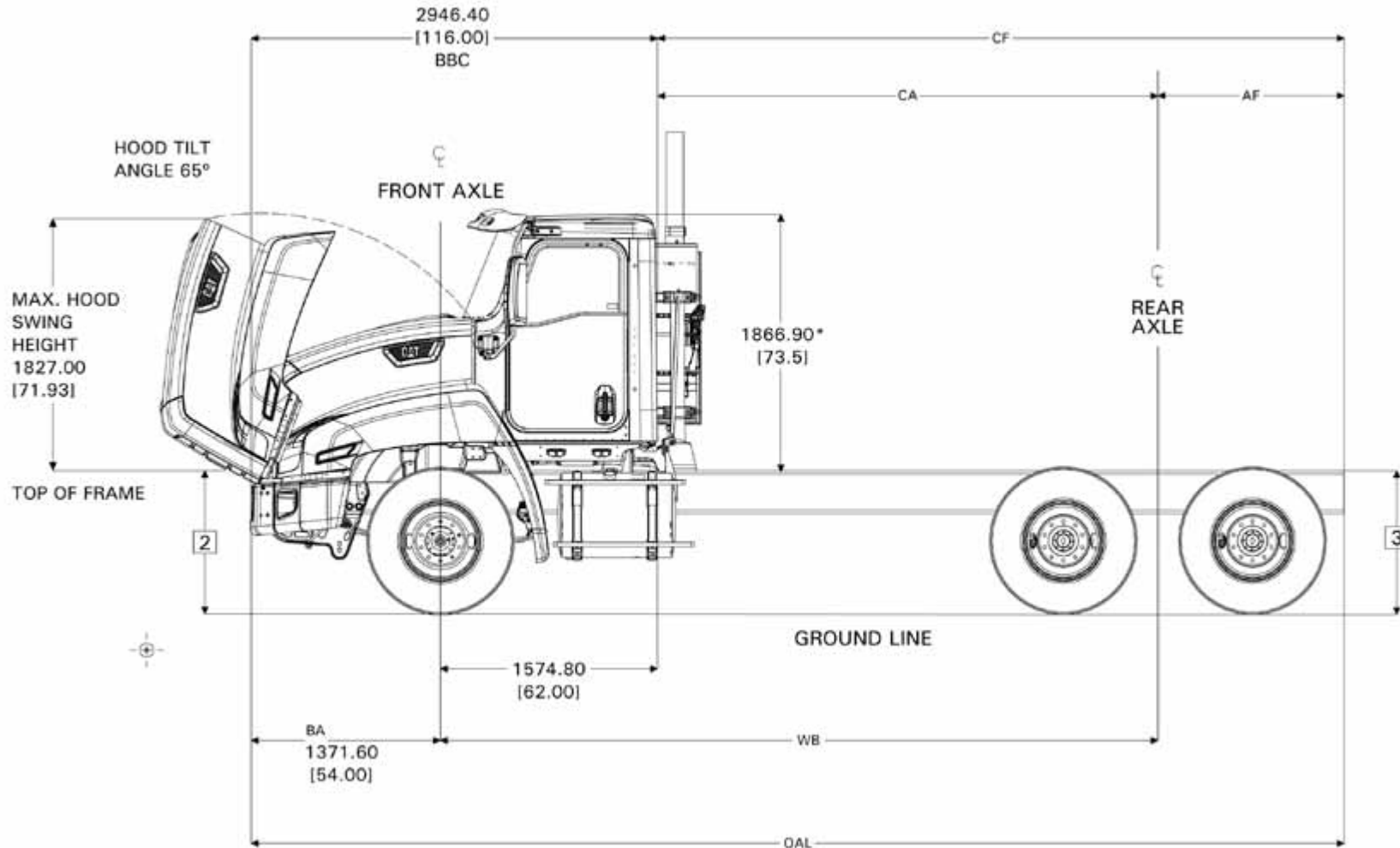

↪ return to table of contents

ALL MODEL SPECIFICATIONS

CT15 CHASSIS DIAGRAMS – HOOD TILT – 6X4 SBA — SIDE VIEW (EGR ONLY)

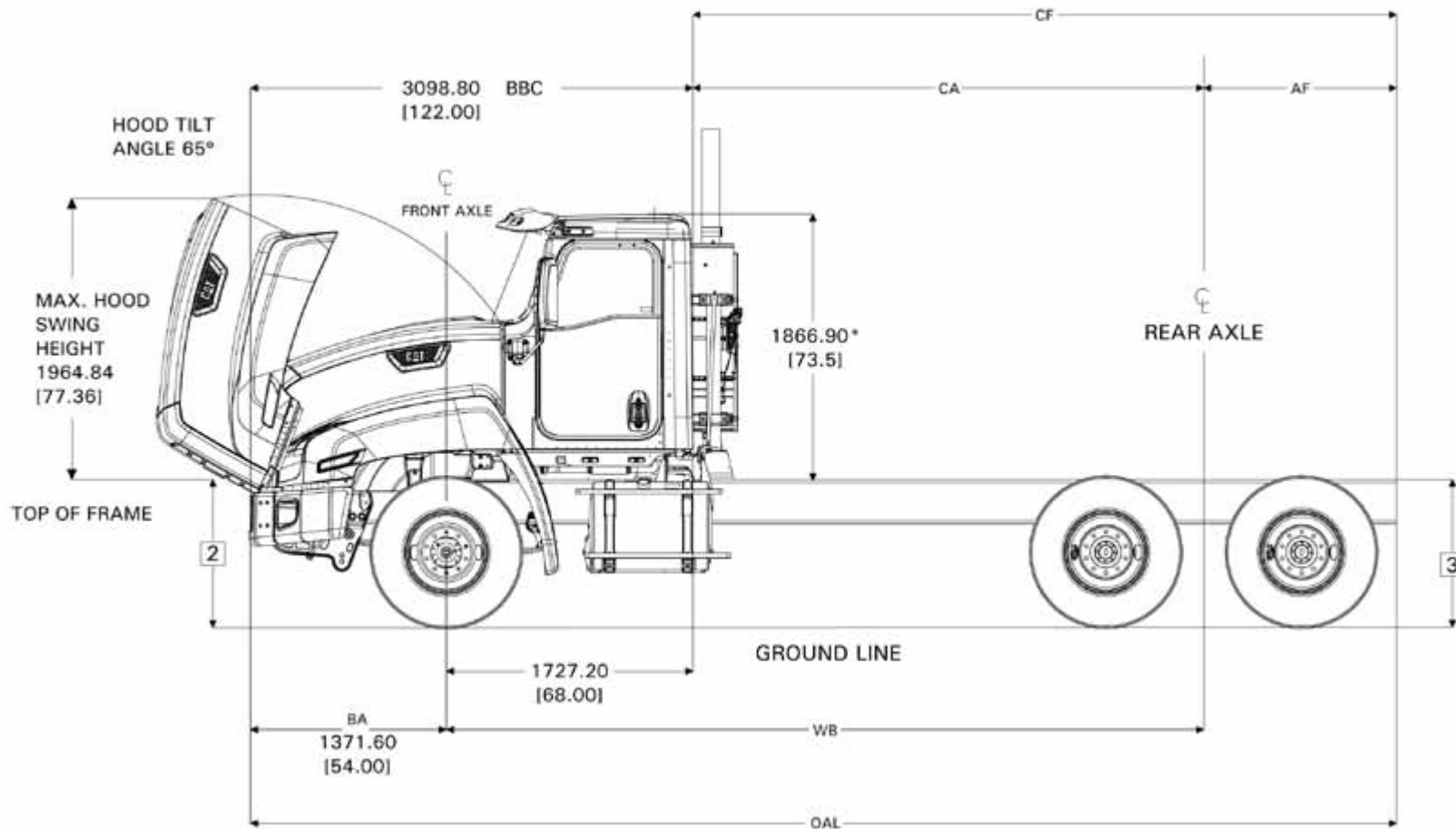

[↶ return to table of contents](#)

CT660 116BBC 6x4 SPECIFICATIONS

CHASSIS DIAGRAMS – HOOD TILT VIEW (SCR ONLY)

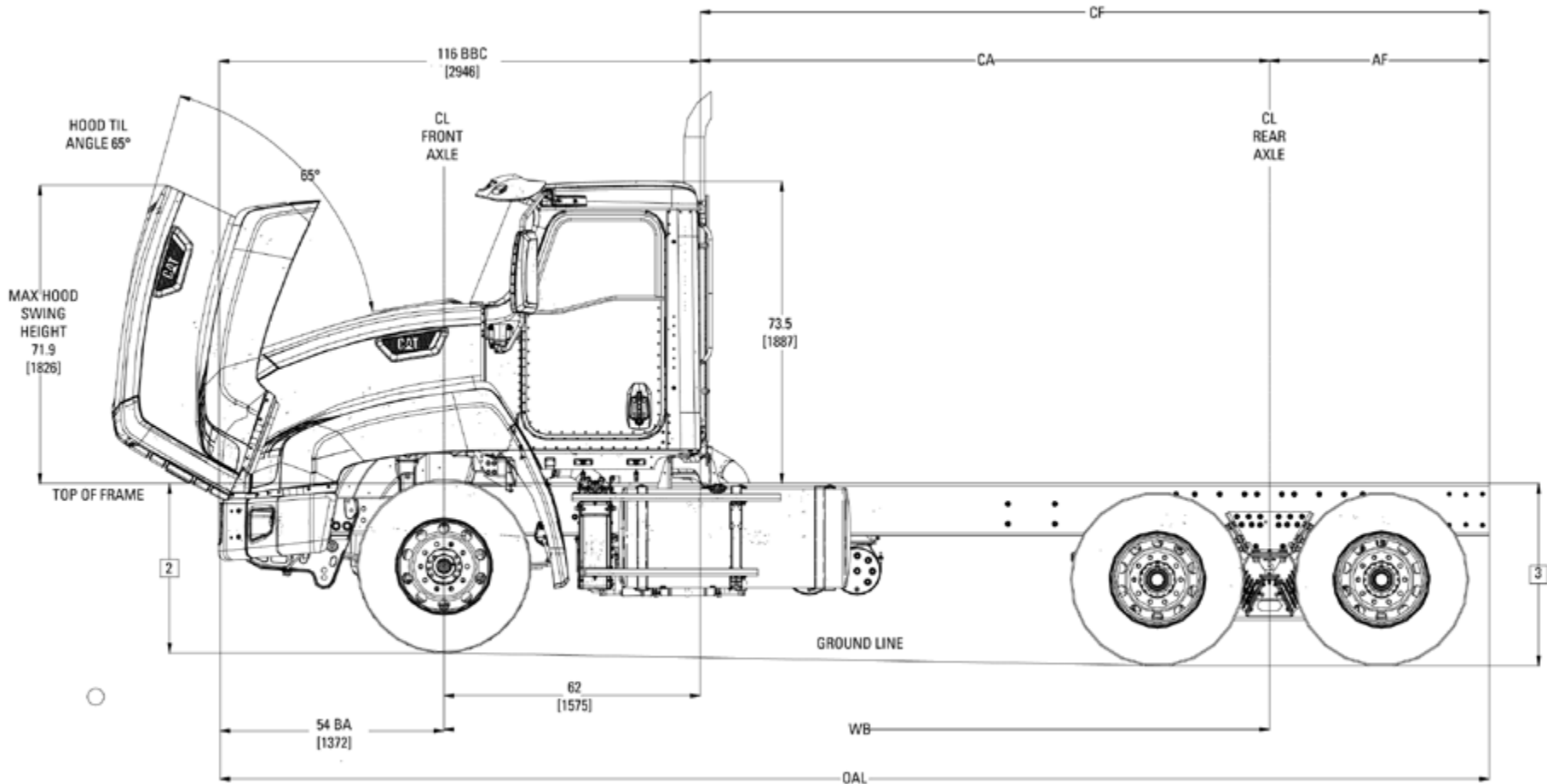

[↶ return to table of contents](#)

CT660 122BBC 6x4 SPECIFICATIONS

CHASSIS DIAGRAMS – HOOD TILT VIEW (SCR ONLY)

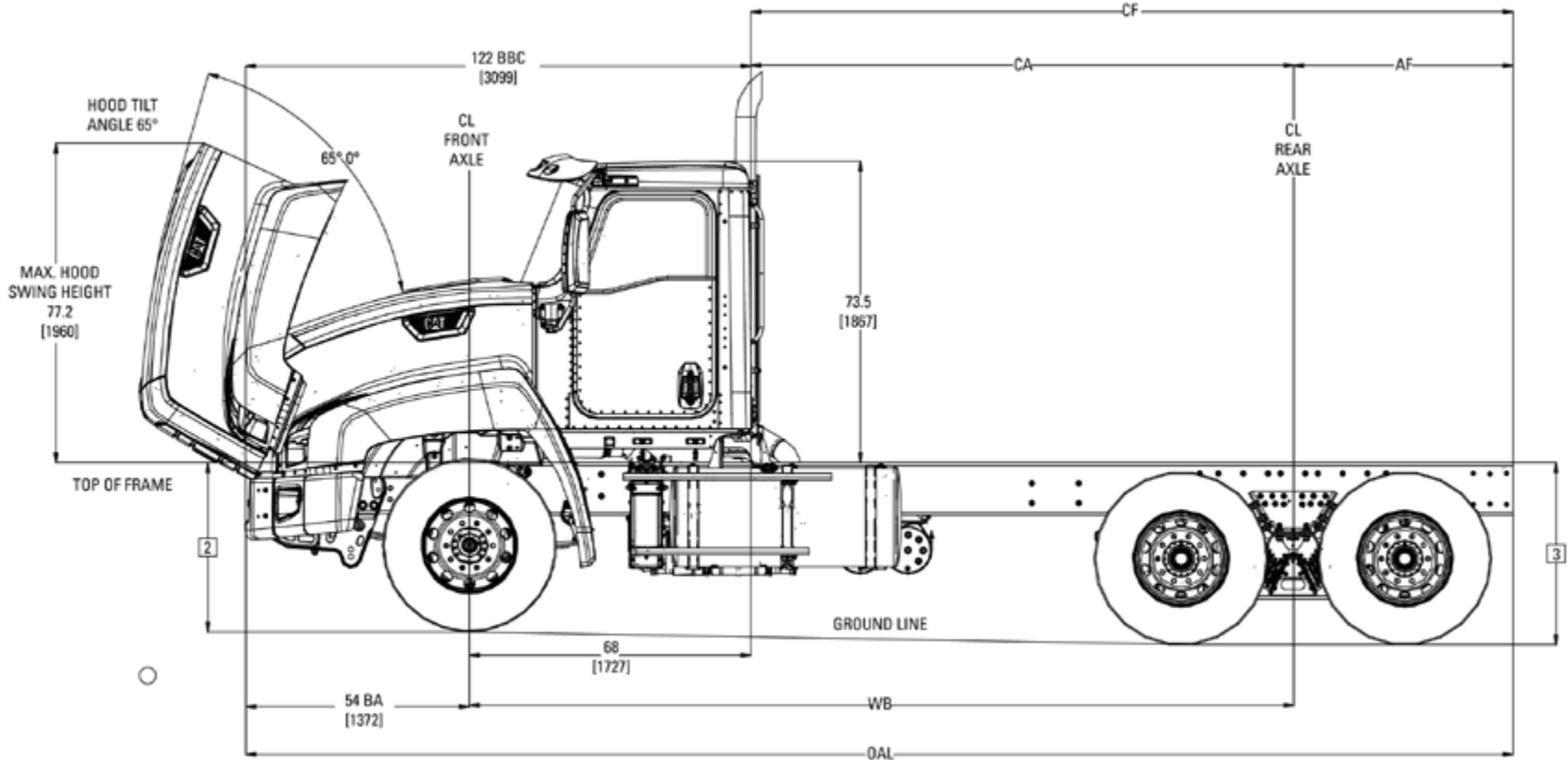

CT660 116BBC 6x4 SPECIFICATIONS

CHASSIS DIAGRAMS – SIDE VIEW (SCR ONLY)

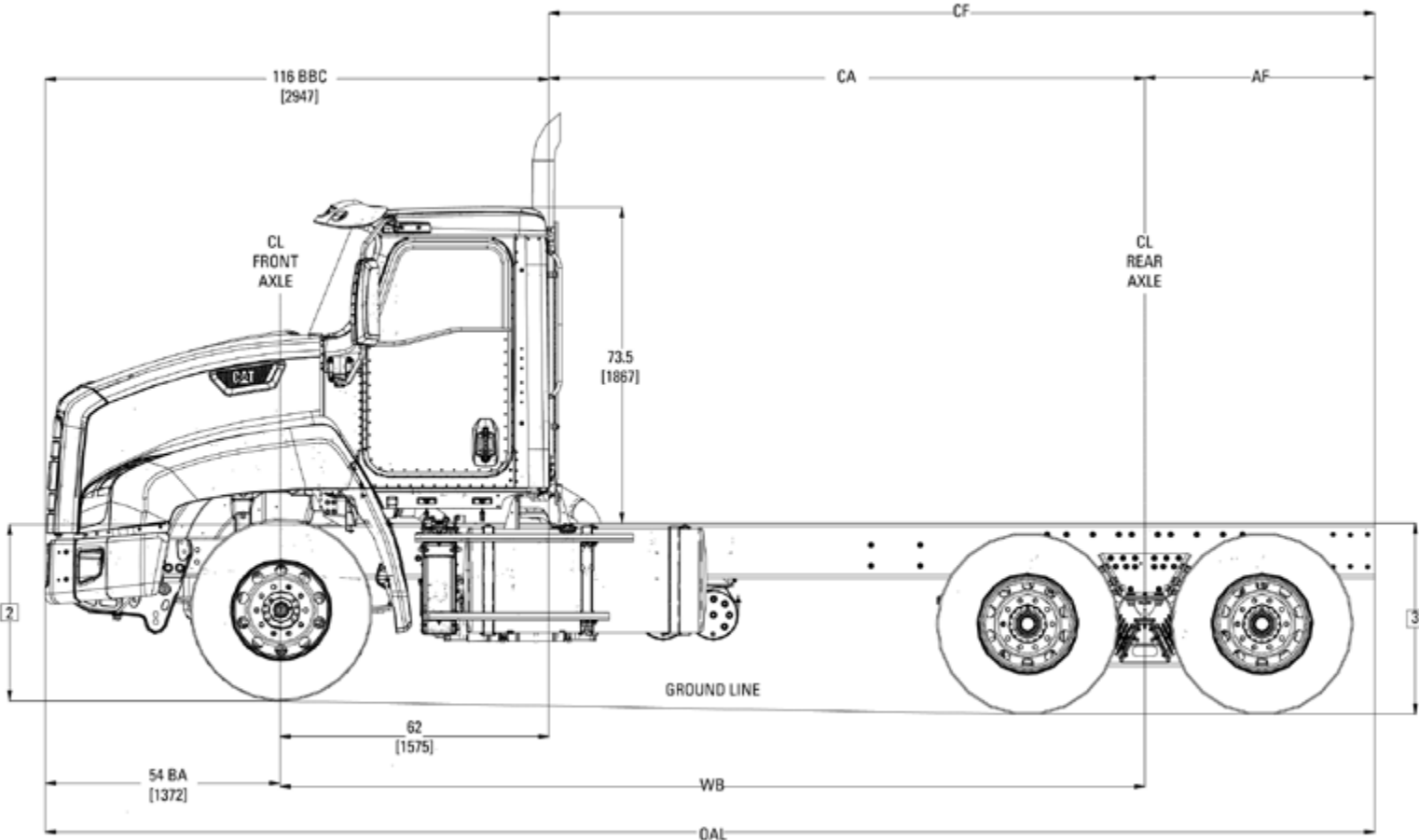

[↶ return to table of contents](#)

CT660 116BBC 8x6 SPECIFICATIONS

CHASSIS DIAGRAMS – SIDE VIEW (SCR ONLY)

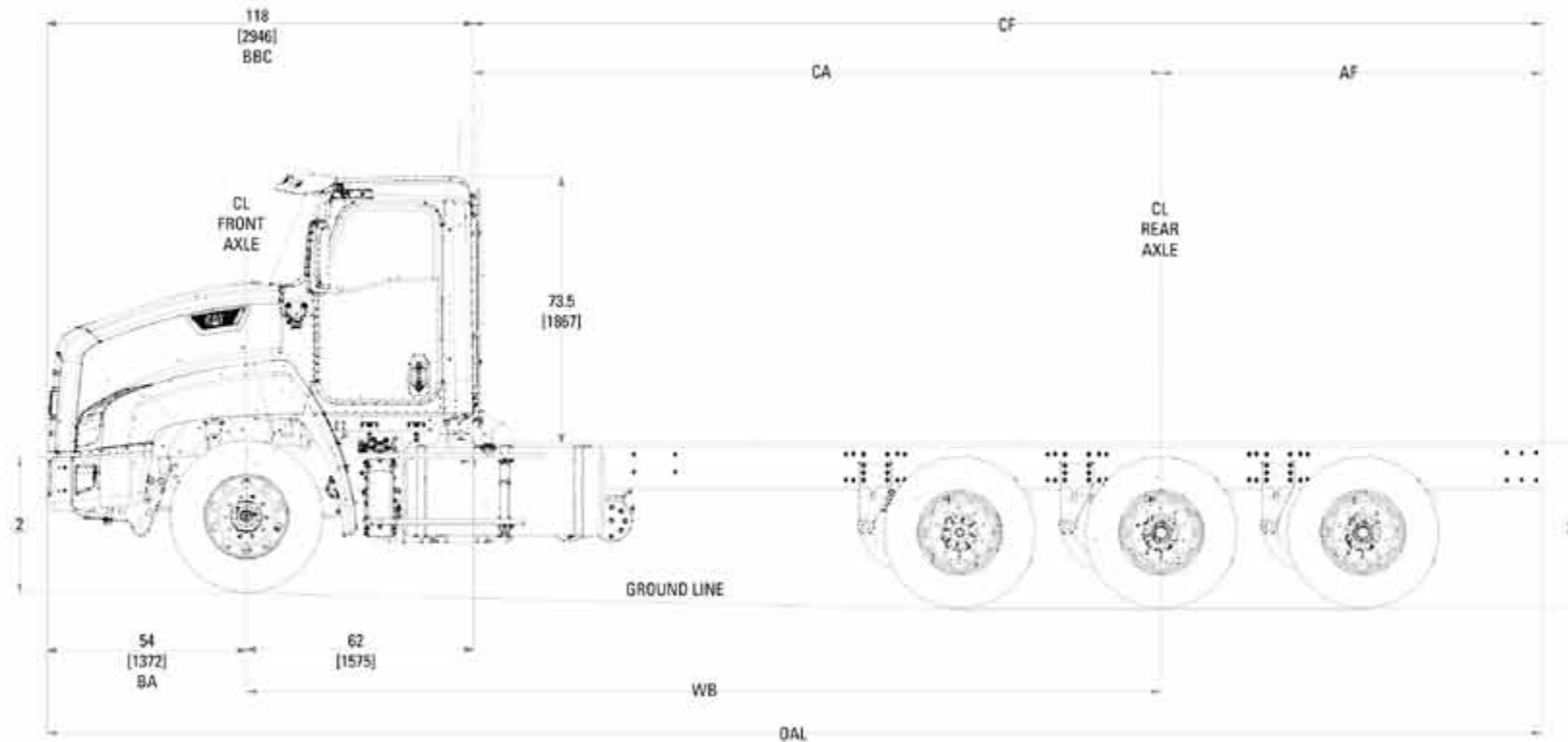

[↶ return to table of contents](#)

CT660 116BBC 6x4 SPECIFICATIONS

CHASSIS DIAGRAMS – (SCR ONLY)

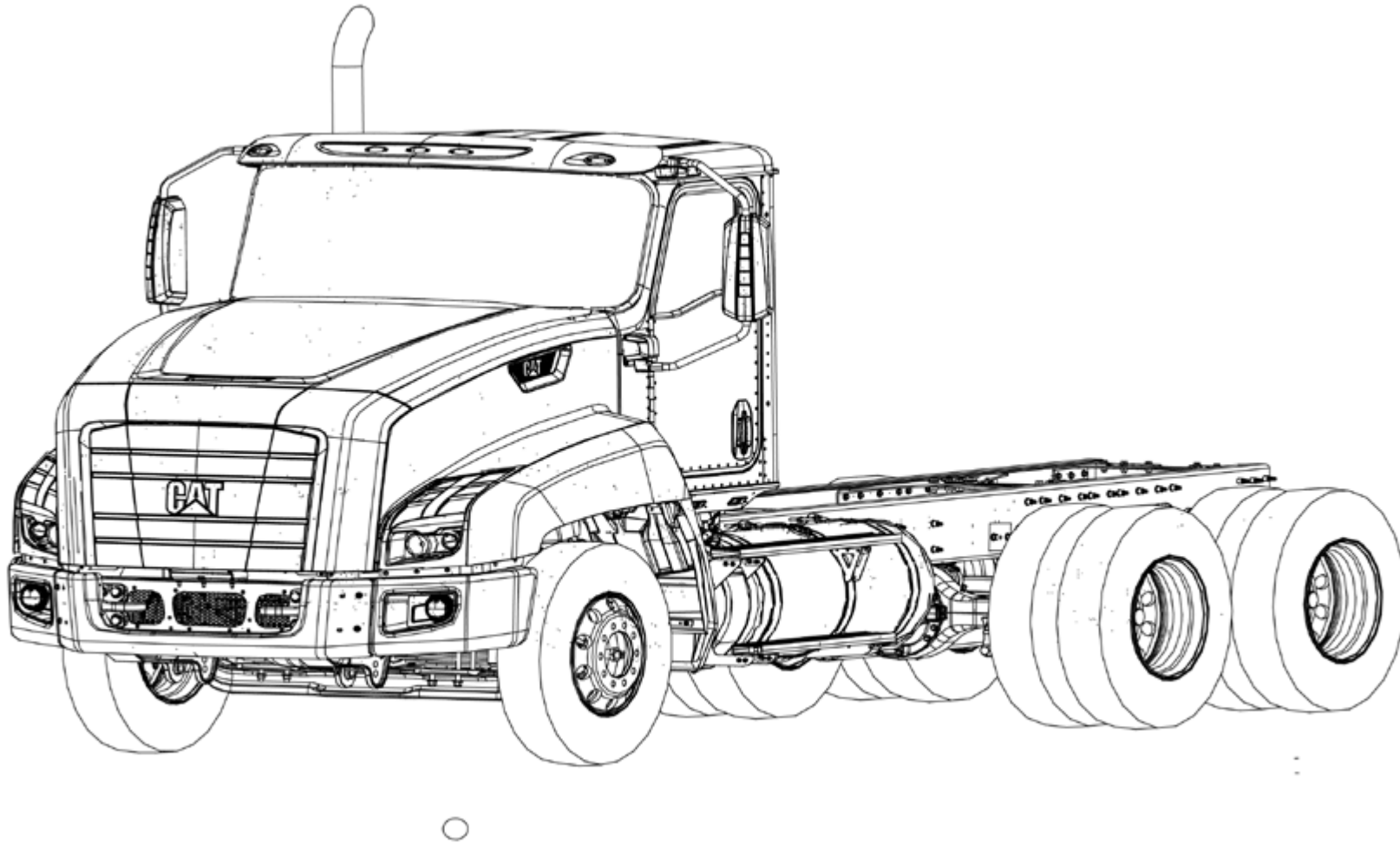

[↶ return to table of contents](#)

CT660 116BBC 8x6 SPECIFICATIONS

CHASSIS DIAGRAMS – (SCR ONLY)

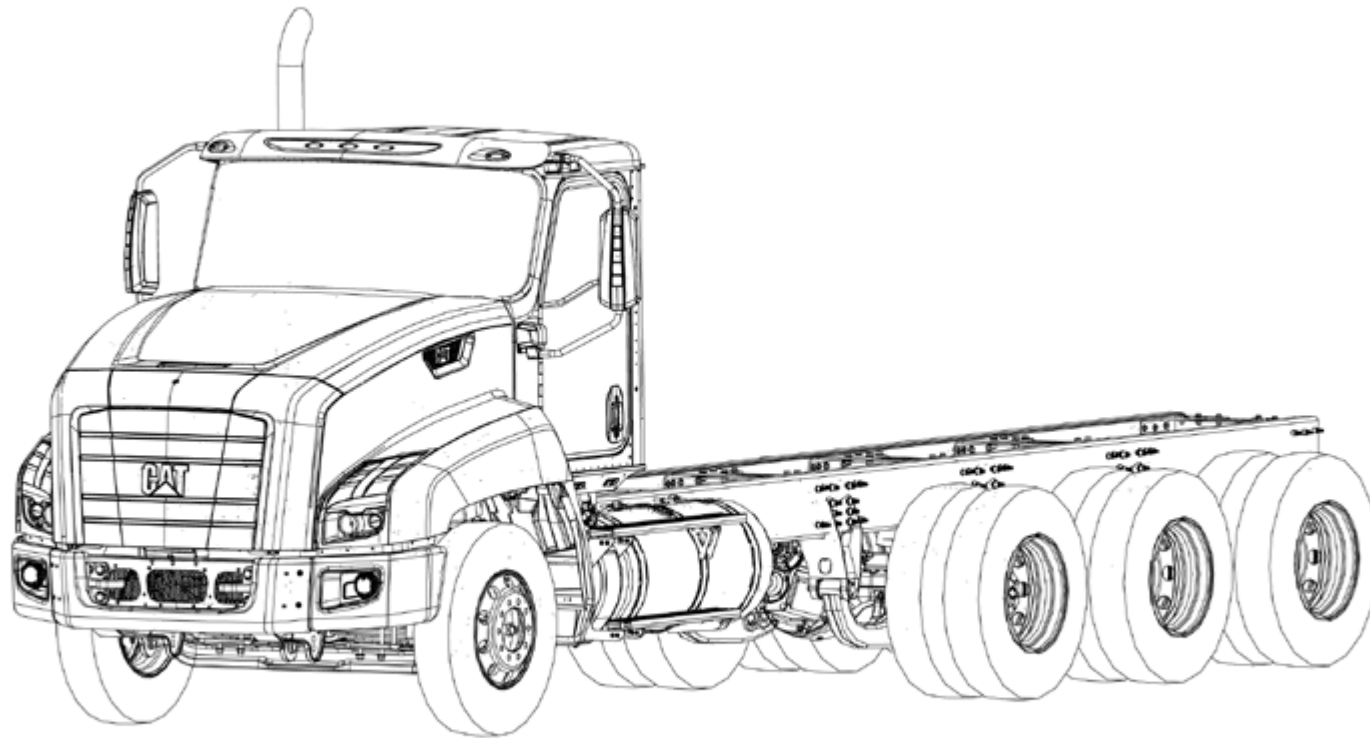

○

[↶ return to table of contents](#)

CT660 122BBC 6x4 SPECIFICATIONS

CHASSIS DIAGRAMS – (SCR ONLY)

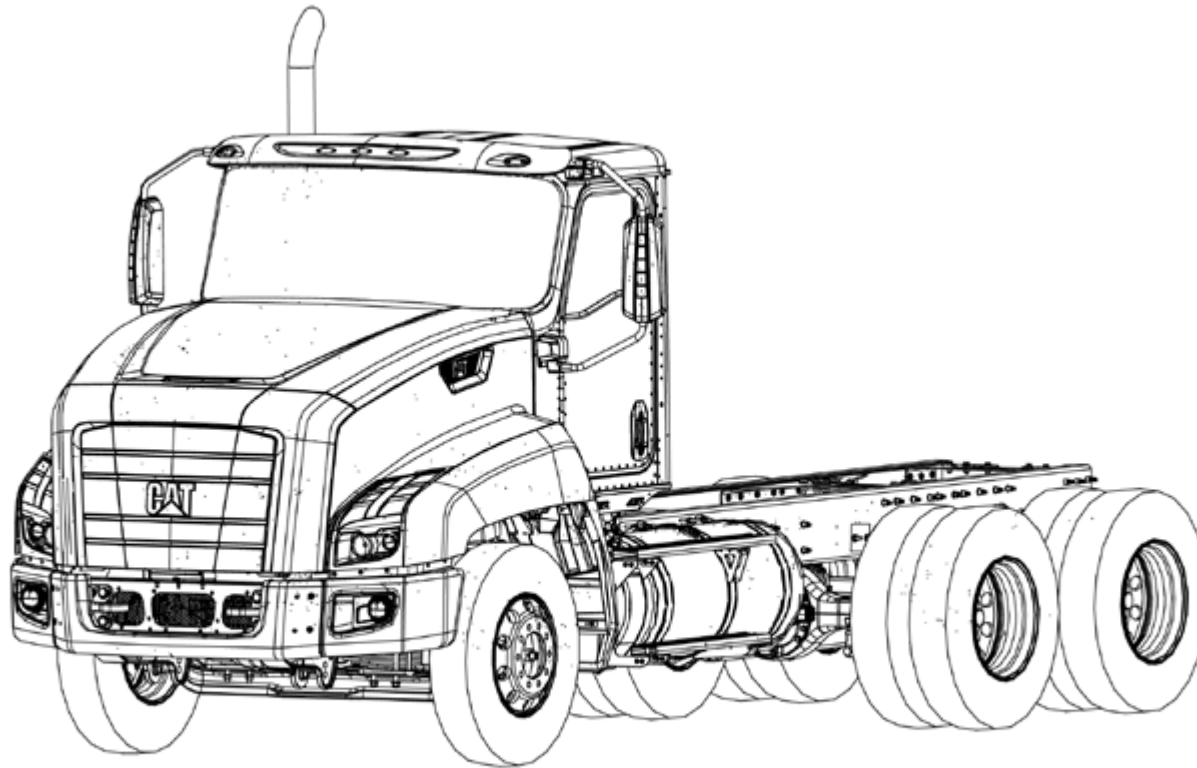

[↶ return to table of contents](#)

CT660 122BBC 8x6 SPECIFICATIONS

CHASSIS DIAGRAMS – (SCR ONLY)

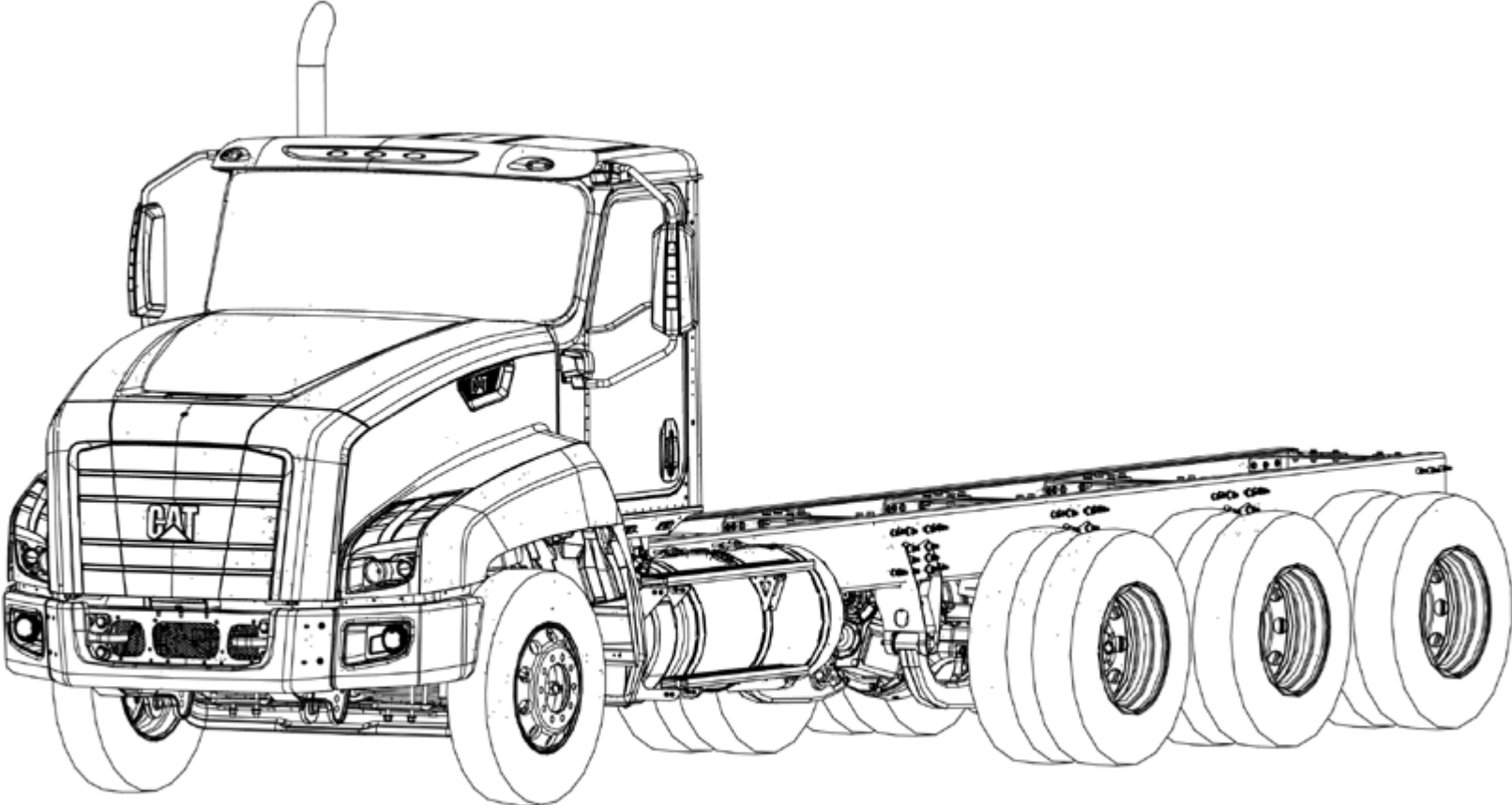

CT660 116BBC 6x4 SPECIFICATIONS

CHASSIS DIAGRAMS – PLAN VIEW (SCR ONLY)

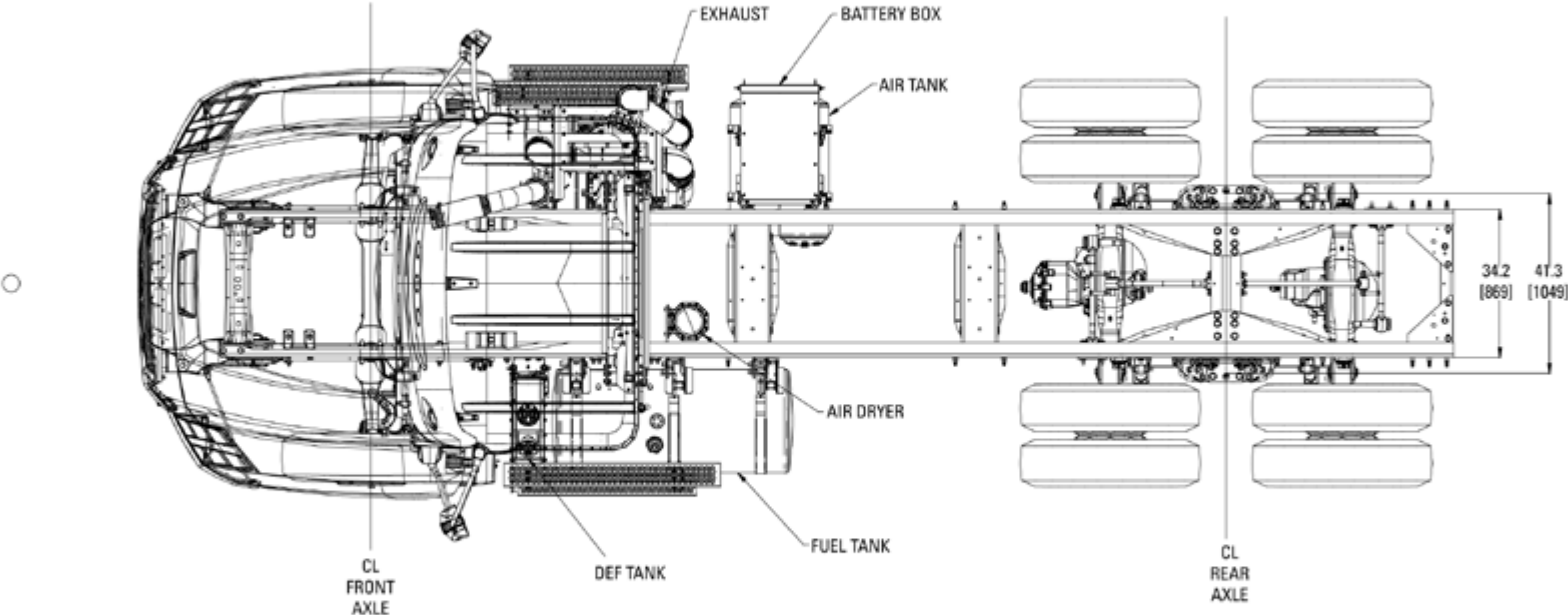

CT660 122BBC 6x4 SPECIFICATIONS

CHASSIS DIAGRAMS – PLAN VIEW (SCR ONLY)

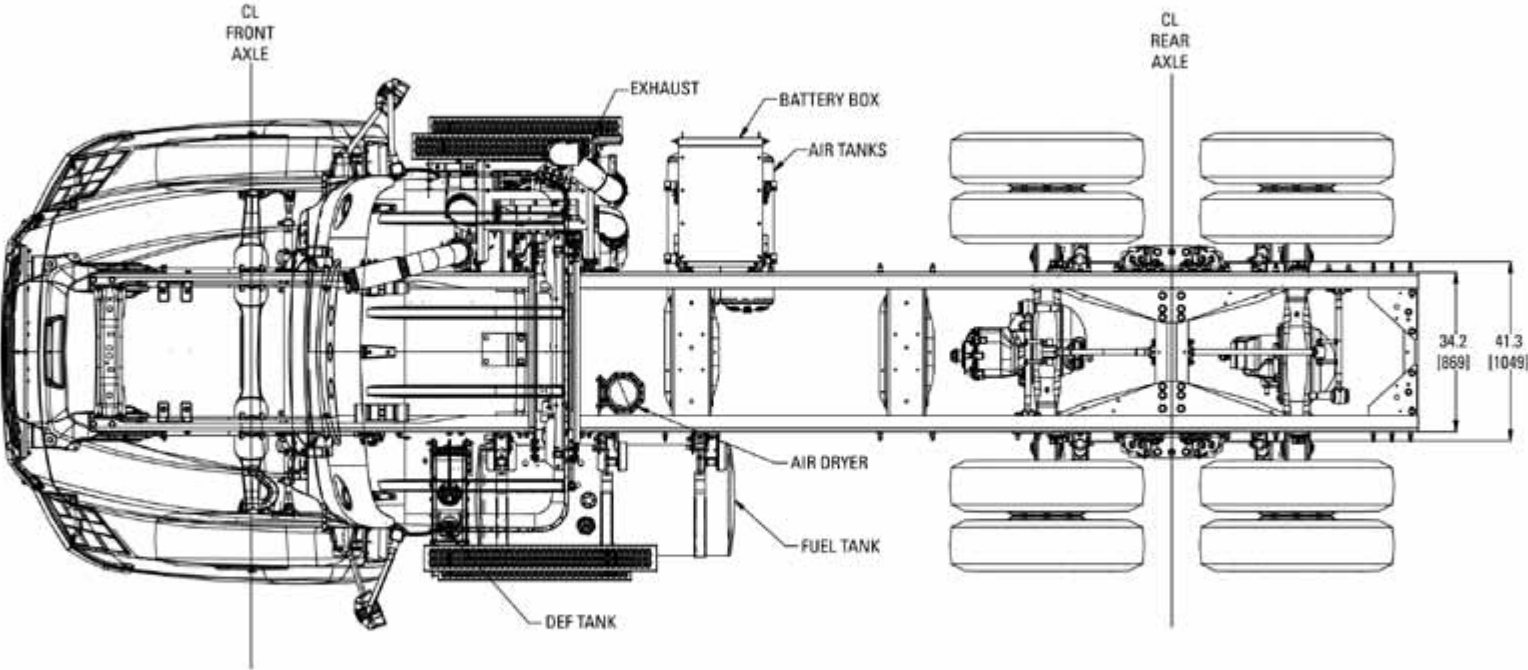

CT660 122BBC 8x6 SPECIFICATIONS

CHASSIS DIAGRAMS – SIDE VIEW (SCR ONLY)

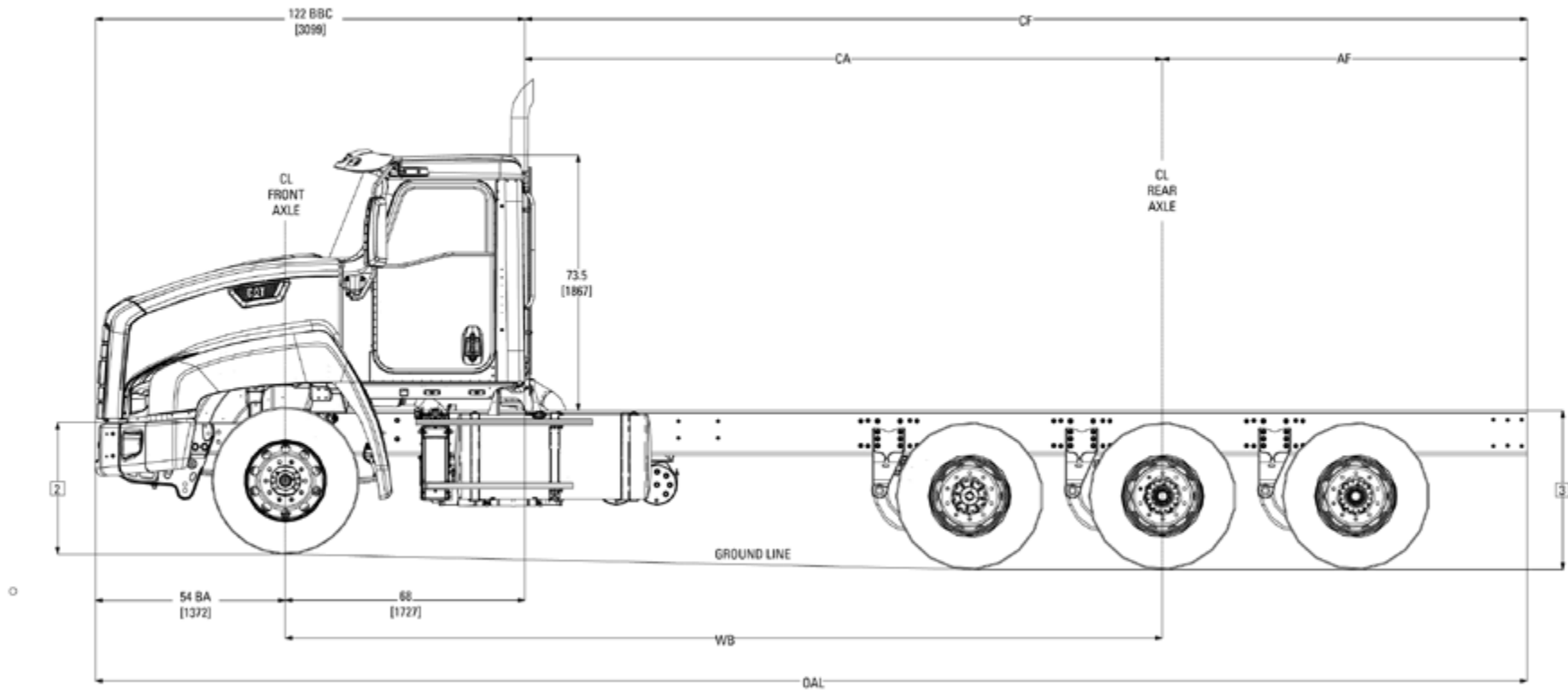

[↶ return to table of contents](#)

CT660 122BBC 8x6 SPECIFICATIONS

CHASSIS DIAGRAMS – PLAN VIEW (SCR ONLY)

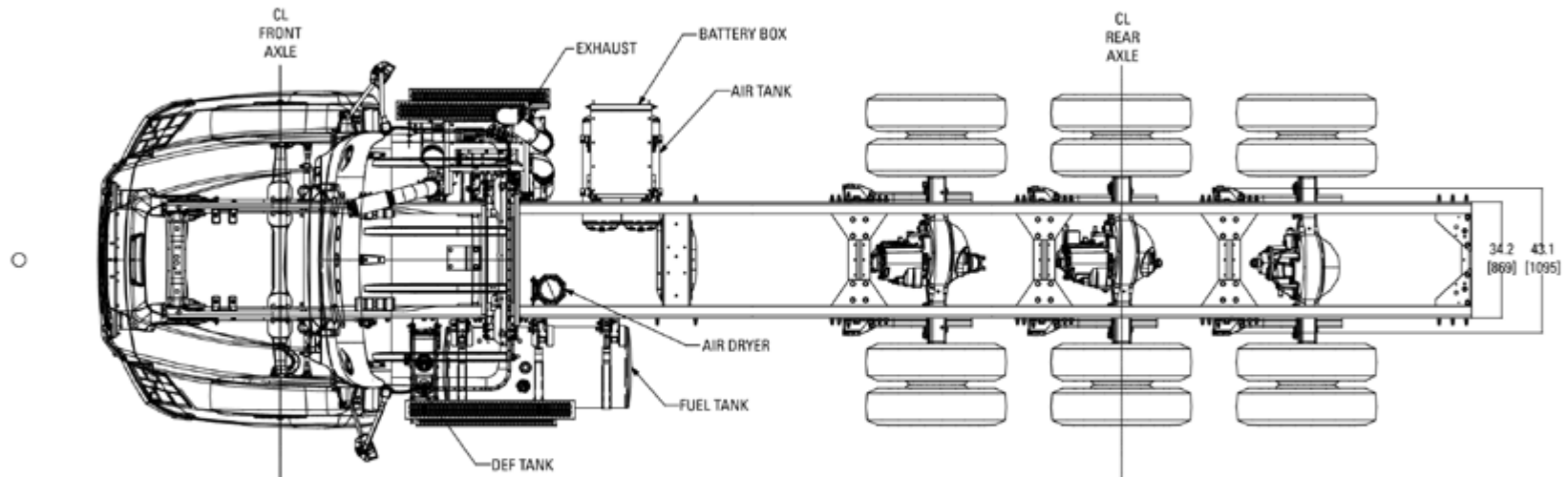

ALL MODEL SPECIFICATIONS

CHASSIS PACKAGING DIAGRAMS (EGR ONLY)

Model SBA 6x4 & 8x6, 60GAL 0015SSN-0015SSM, 80GAL 0015SGL-0015SSL, Vertical/Vertical 0007BDS and 0007SCS, Aux. Air Tank 0504078, Battery Box and Air Tanks 0008WKG w/ 0504603

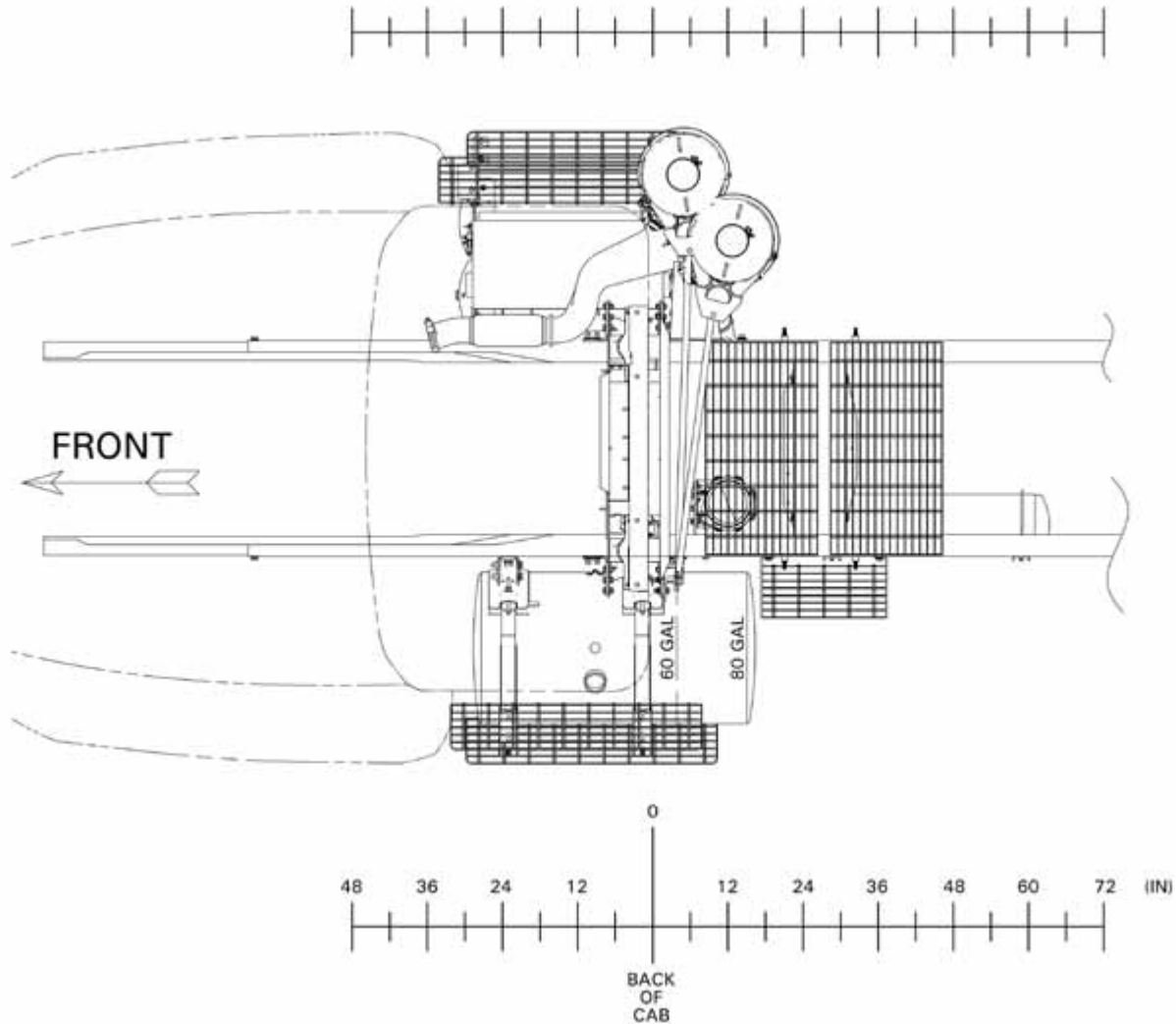

[↶ return to table of contents](#)

ALL MODEL SPECIFICATIONS

CHASSIS PACKAGING DIAGRAMS (EGR ONLY)

Model SBA 4x4 & 6x6, 60GAL 0015SSN-0015SSM, 80GAL 0015SGL-0015SSL, Vertical/Vertical 0007BDS and 0007SCS, Aux. Air Tank 0504078, Battery Box and Air Tanks 0008WKG w/ 0504603, Transfer Case 13TJGTC

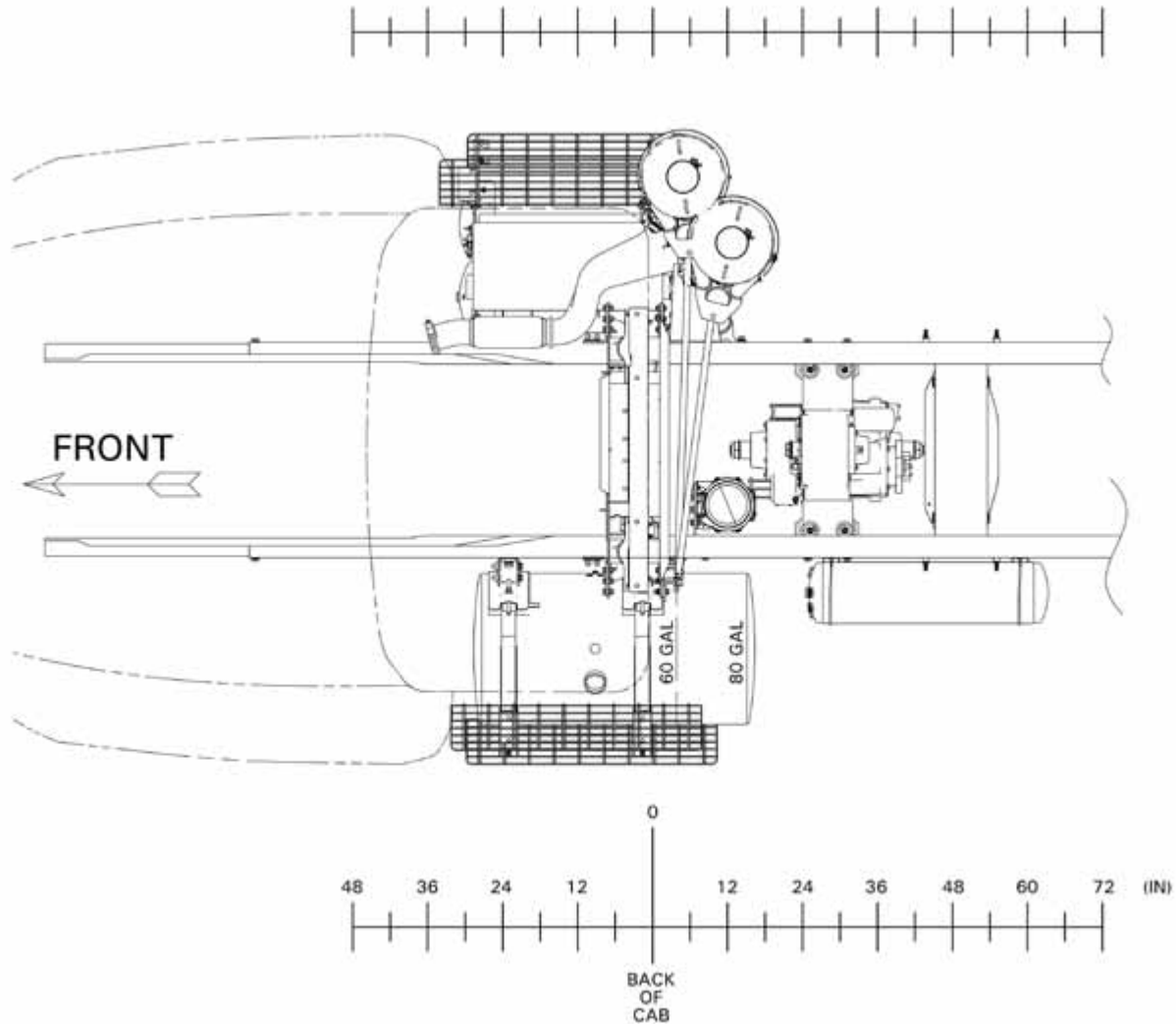

[↶ return to table of contents](#)

ALL MODEL SPECIFICATIONS

CHASSIS PACKAGING DIAGRAMS (EGR ONLY)

Model SBA 4x4 & 6x6, 100GAL 0015SHC-0015SSK, 120GAL 0015SMZ-0015SSG, Vertical/Vertical 0007BDS and 0007SCS, Aux. Air Tank 0504078, Battery Box and Air Tanks 0008WKG w/ 0504603, Hydraulic Tank 0015WBV and 0015WTN

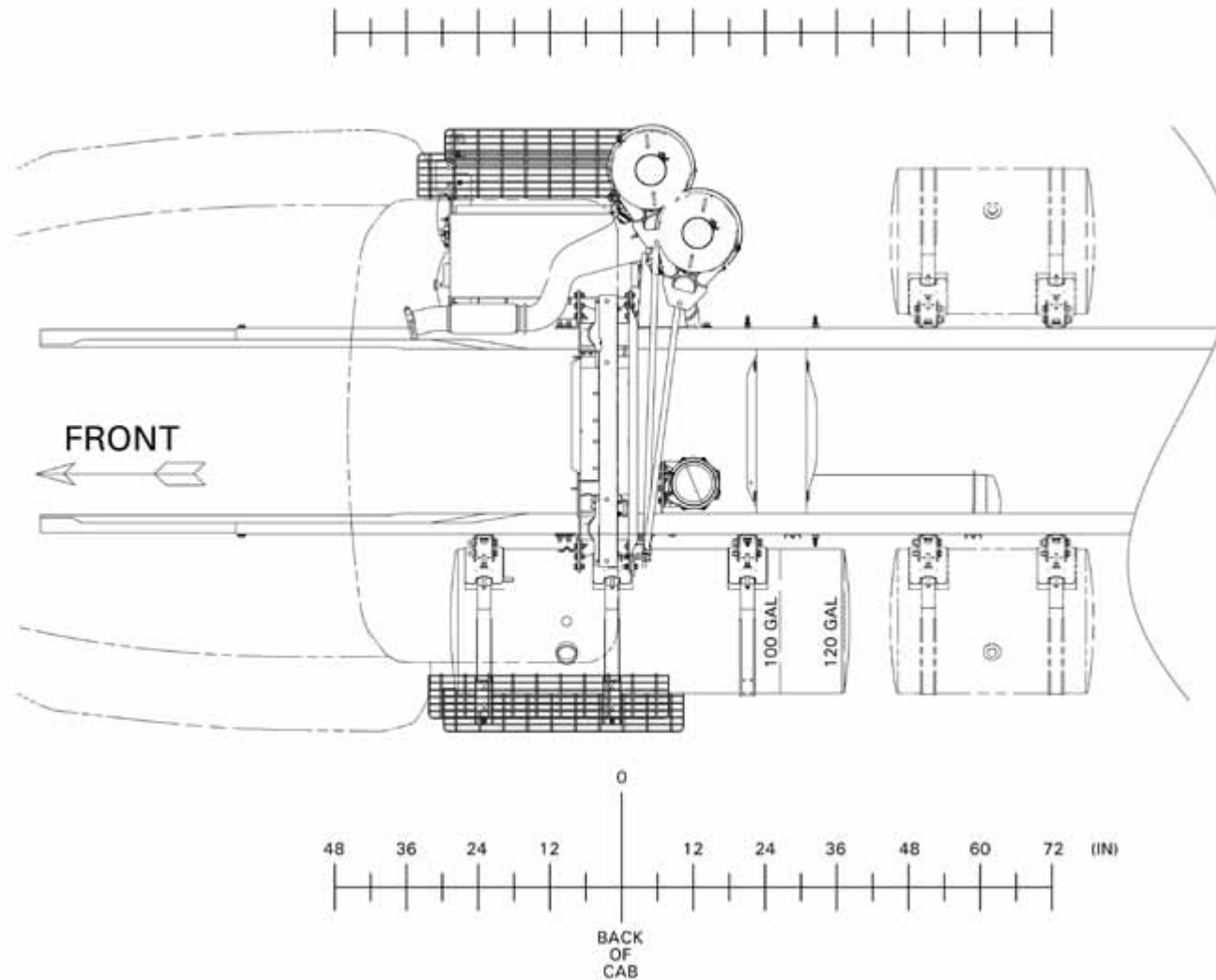

[↶ return to table of contents](#)

ALL MODEL SPECIFICATIONS

CHASSIS PACKAGING DIAGRAMS (EGR ONLY)

Model SBA 6x4 & 8x6, 100GAL 0015SHC-0015SSK, 120GAL 0015SMZ-0015SSG, Vertical/Vertical 0007BDS and 0007SCS, Aux. Air Tank 0504078, Battery Box and Air Tanks 0008WKG w/ 0504603

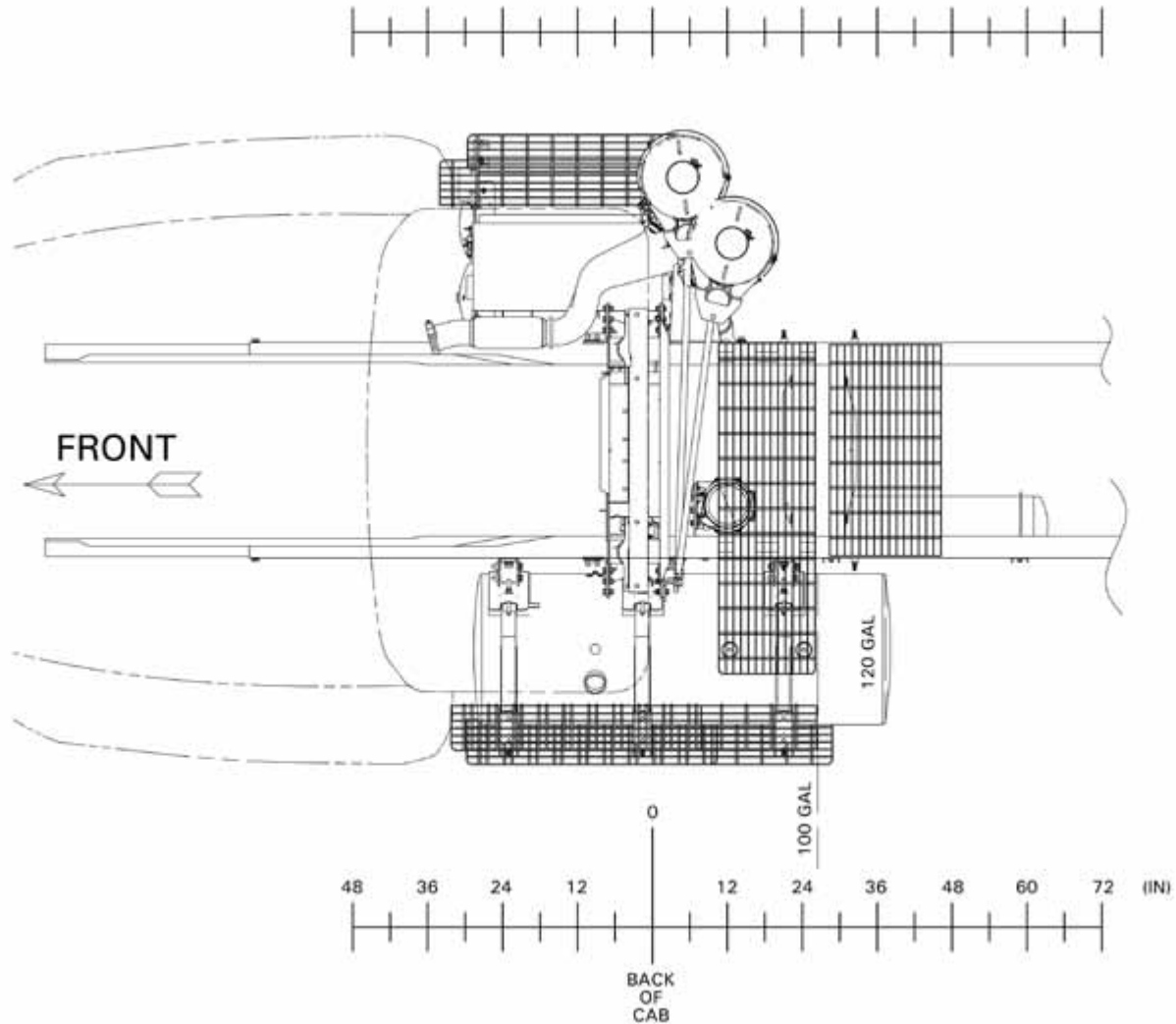

↪ return to table of contents

ALL MODEL SPECIFICATIONS

CHASSIS PACKAGING DIAGRAMS (EGR ONLY)

Model SBA 4x4 & 6x6, 100GAL 0015SHC-0015SSK, 120GAL 0015SMZ-0015SSG, Vertical/Vertical 0007BDS and 0007SCS, Aux. Air Tank 0504078, Battery Box and Air Tanks 0008WKG w/ 0504603, Transfer Case 13TJGTC

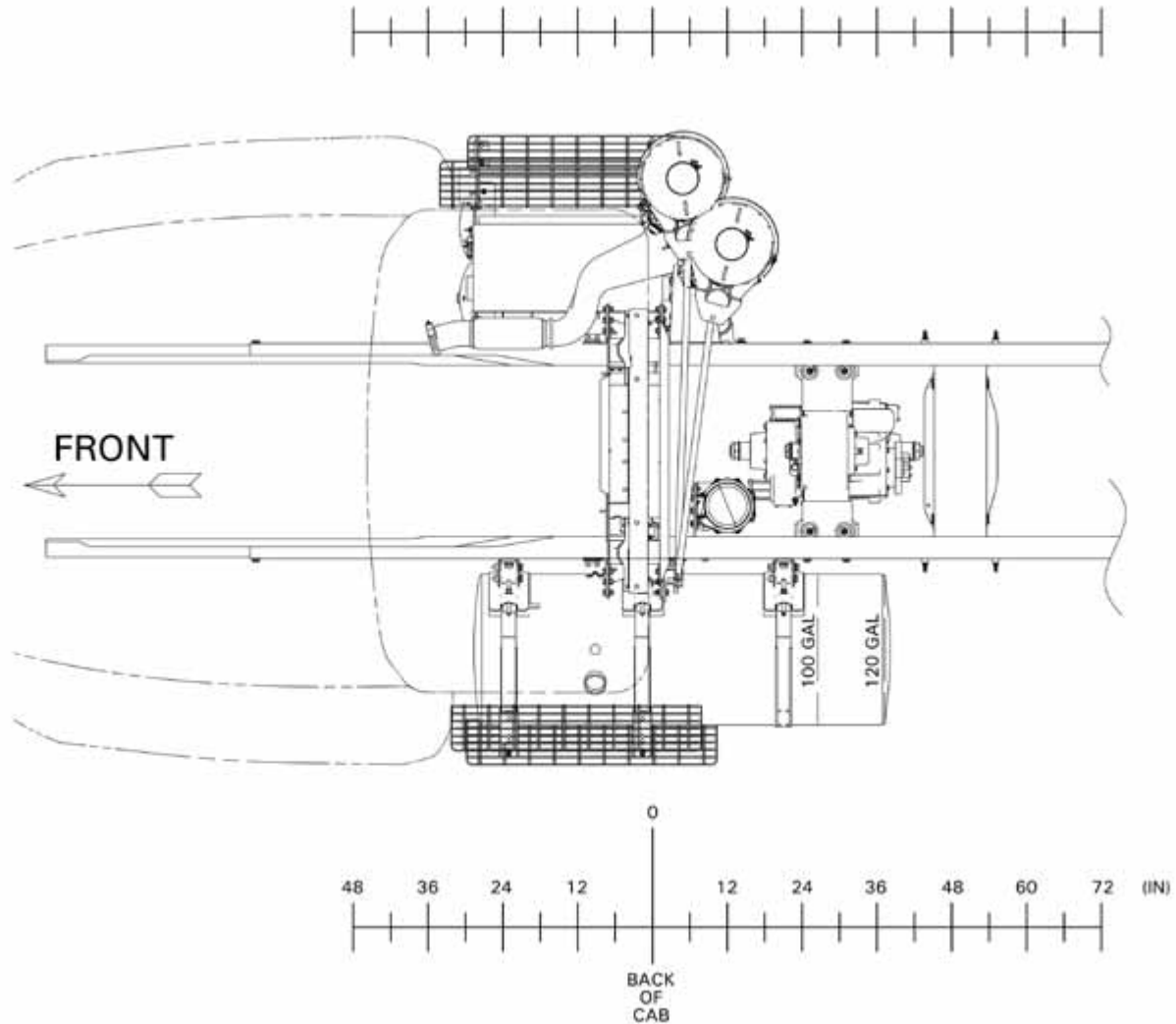

[↶ return to table of contents](#)

ALL MODEL SPECIFICATIONS

CHASSIS PACKAGING DIAGRAMS (EGR ONLY)

Model SBA 6x4 & 8x6, 60GAL 0015SEH-0015SEJ, 80GAL 0015SDJ-0015SEK, Vertical/Vertical 0007BDS and 0007SCS, Aux. Air Tank 0504078, Battery Box and Air Tanks 0008WKE w/ 0504602, Hydraulic Tank 0015WBV and 0015WTN

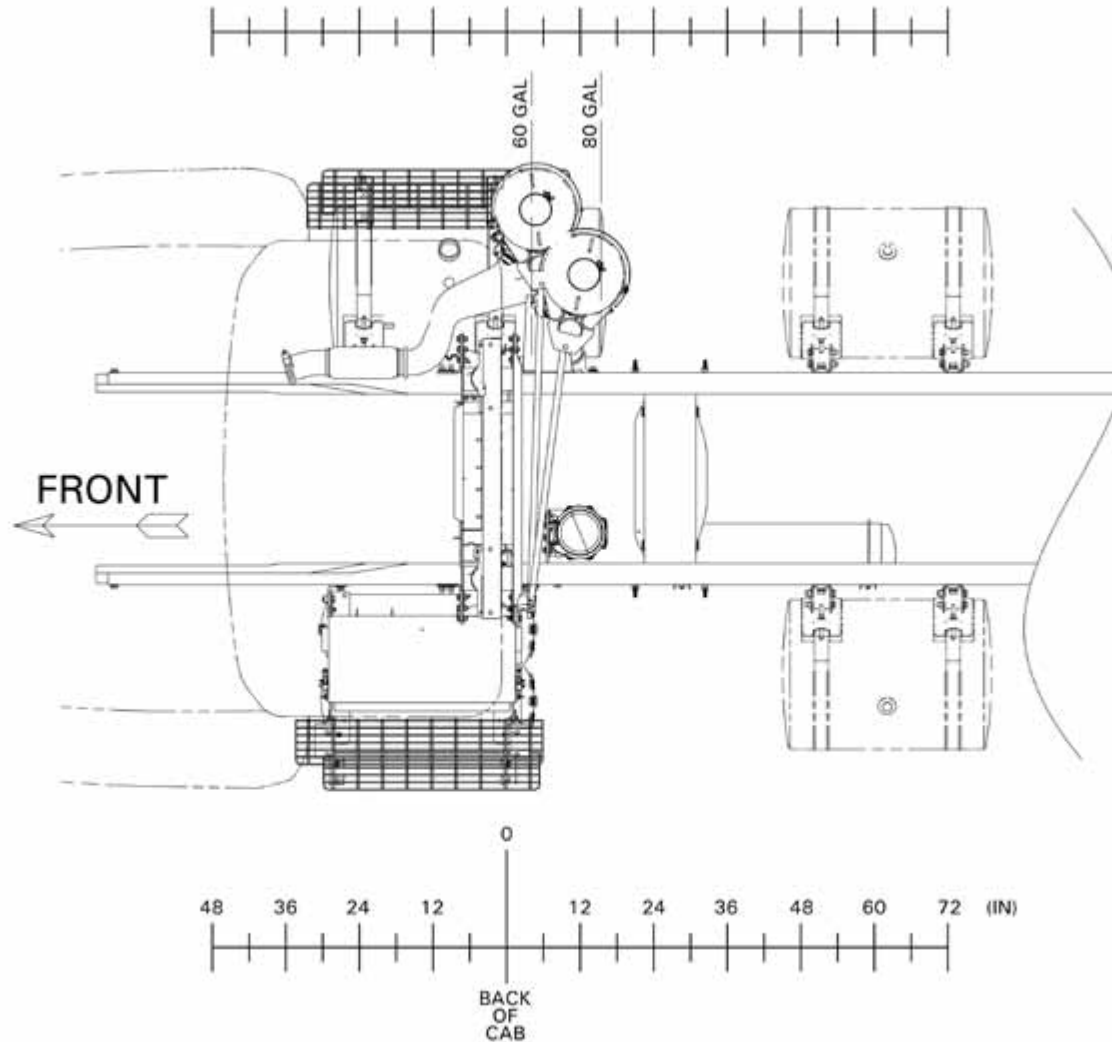

ALL MODEL SPECIFICATIONS

CHASSIS PACKAGING DIAGRAMS (EGR ONLY)

Model SBA 6x4 & 8x6, 60GAL 0015SEH-0015SEJ, 80GAL 0015SDJ-0015SEK, Vertical/Vertical 0007BDS and 0007SCS, Aux. Air Tank 0504078, Battery Box and Air Tanks 0008WKE w/ 0504602

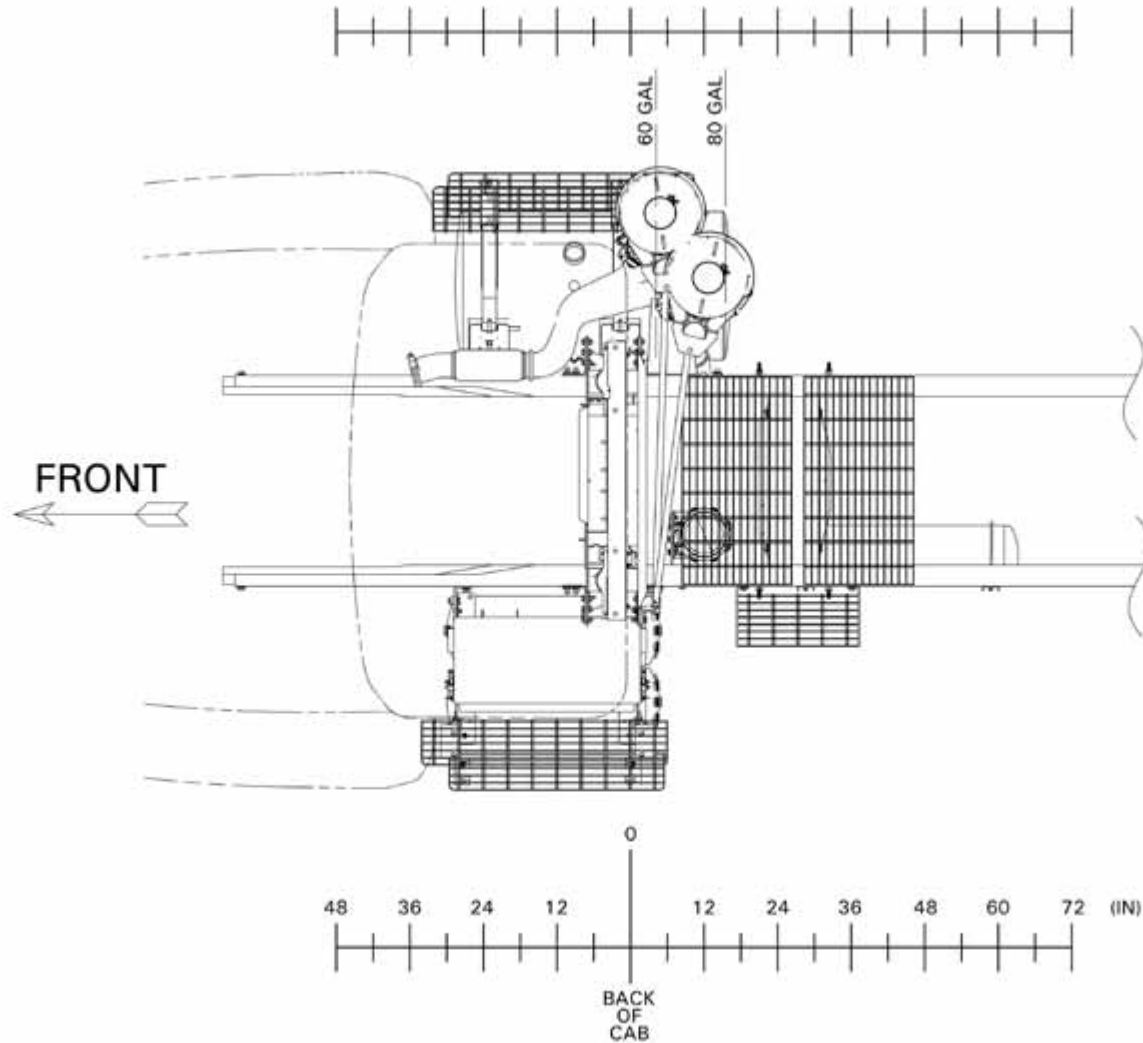

[↶ return to table of contents](#)

ALL MODEL SPECIFICATIONS

CHASSIS PACKAGING DIAGRAMS (EGR ONLY)

Model SBA 4x4 & 6x6, 60GAL 0015SEH-0015SEJ, 80GAL 0015SDJ-0015SEK, Vertical/Vertical 0007BDS and 0007SCS, Aux. Air Tank 0504078, Battery Box and Air Tanks 0008WKE w/ 0504602, Transfer Case 13TJGTC

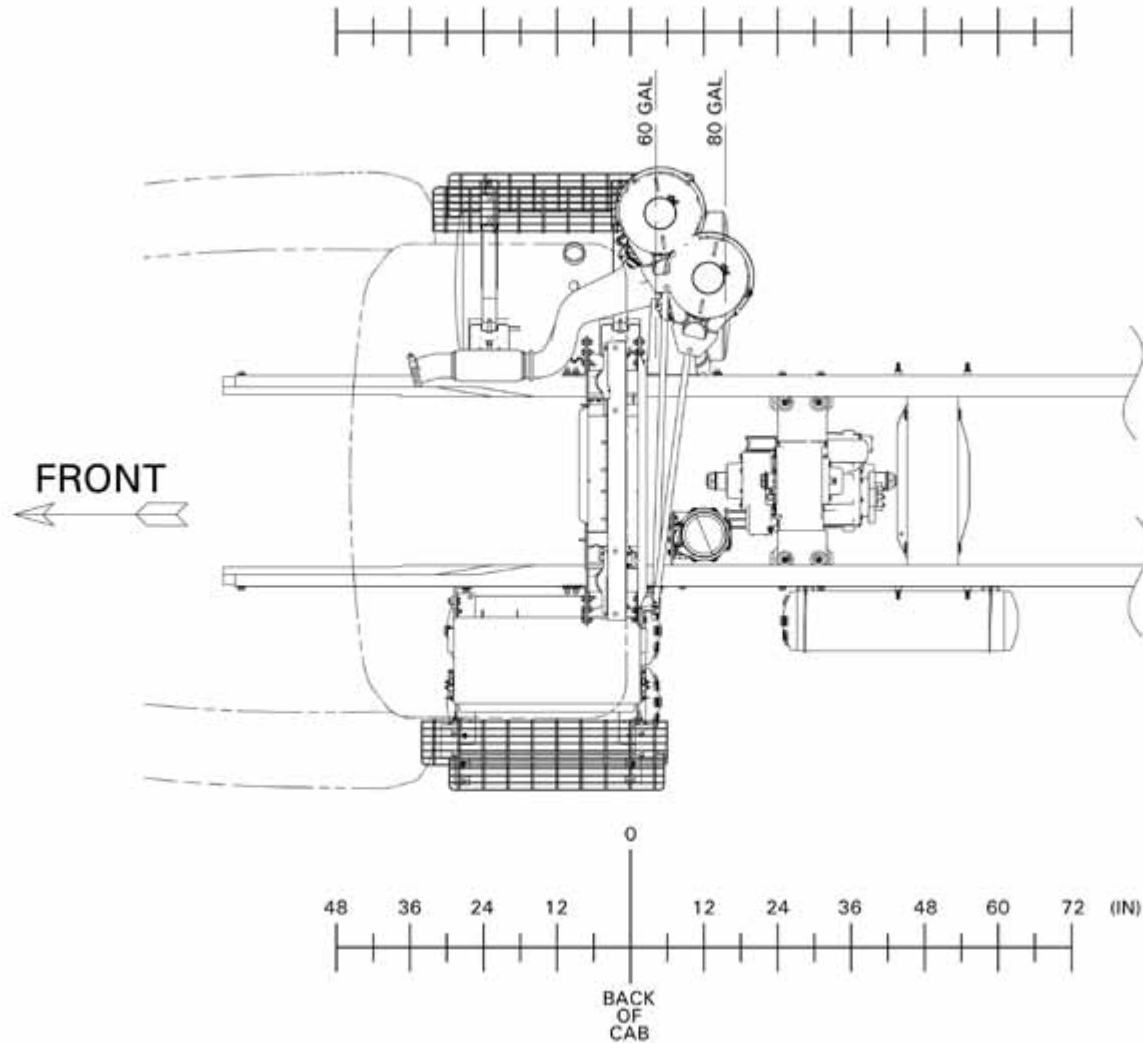

[↶ return to table of contents](#)

ALL MODEL SPECIFICATIONS

CHASSIS PACKAGING DIAGRAMS (EGR ONLY)

Model SBA 6x4 & 8x6, 100GAL 0015561-0015562, 120GAL 0015SEJ-0015SEH, Vertical/Vertical 0007BDS and 0007SCS, Aux. Air Tank 0504078, Battery Box and Air Tanks 0008WKE w/ 0504602, Hydraulic Tank 0015WBV and 0015WTN

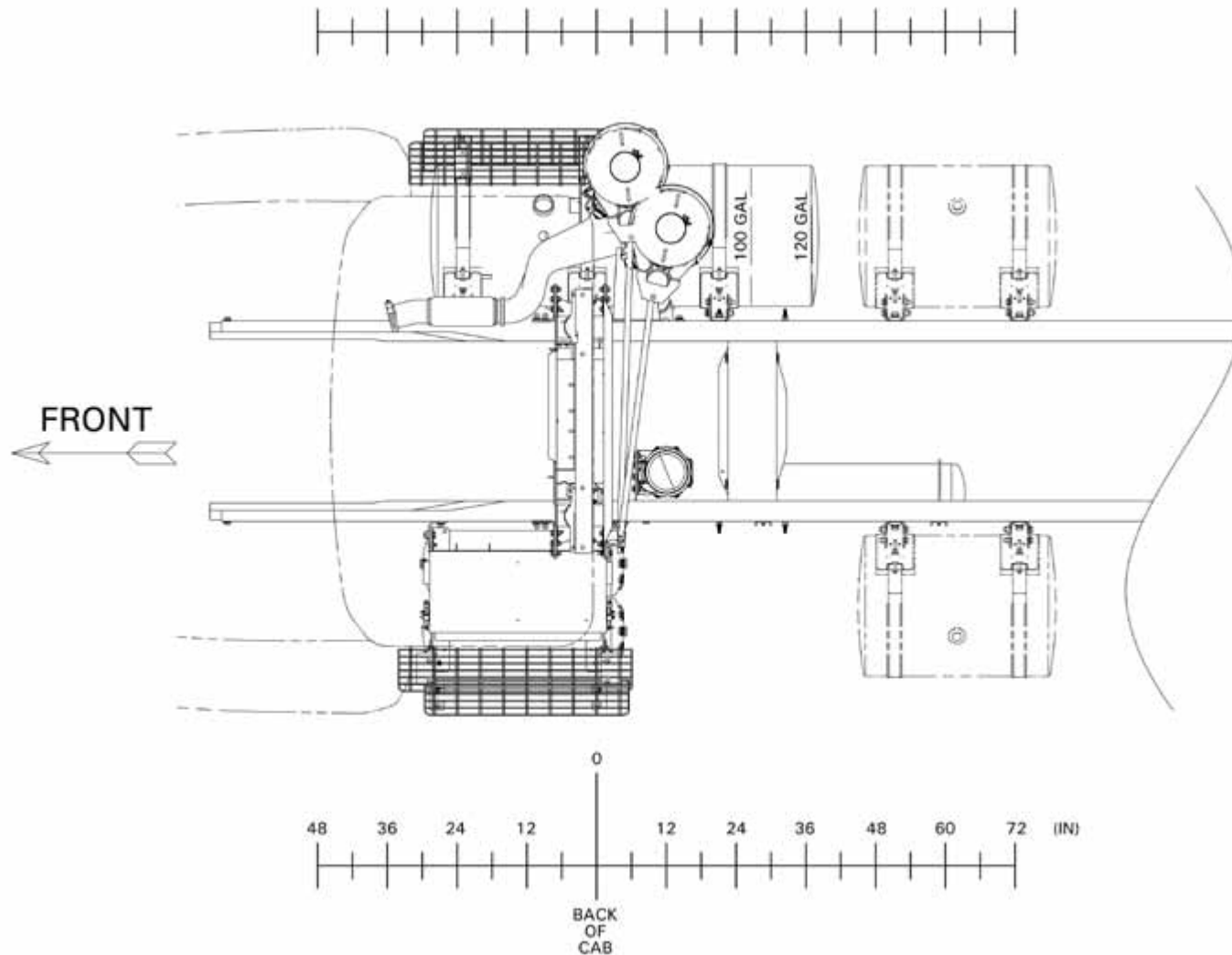

↶ return to table of contents

ALL MODEL SPECIFICATIONS

CHASSIS PACKAGING DIAGRAMS (EGR ONLY)

Model SBA 6x4 & 8x6, 100GAL 0015561-0015562, 120GAL 0015SEJ-0015SEH, Vertical/Vertical 0007BDS and 0007SCS, Aux. Air Tank 0504078, Battery Box and Air Tanks 0008WKE w/ 0504602

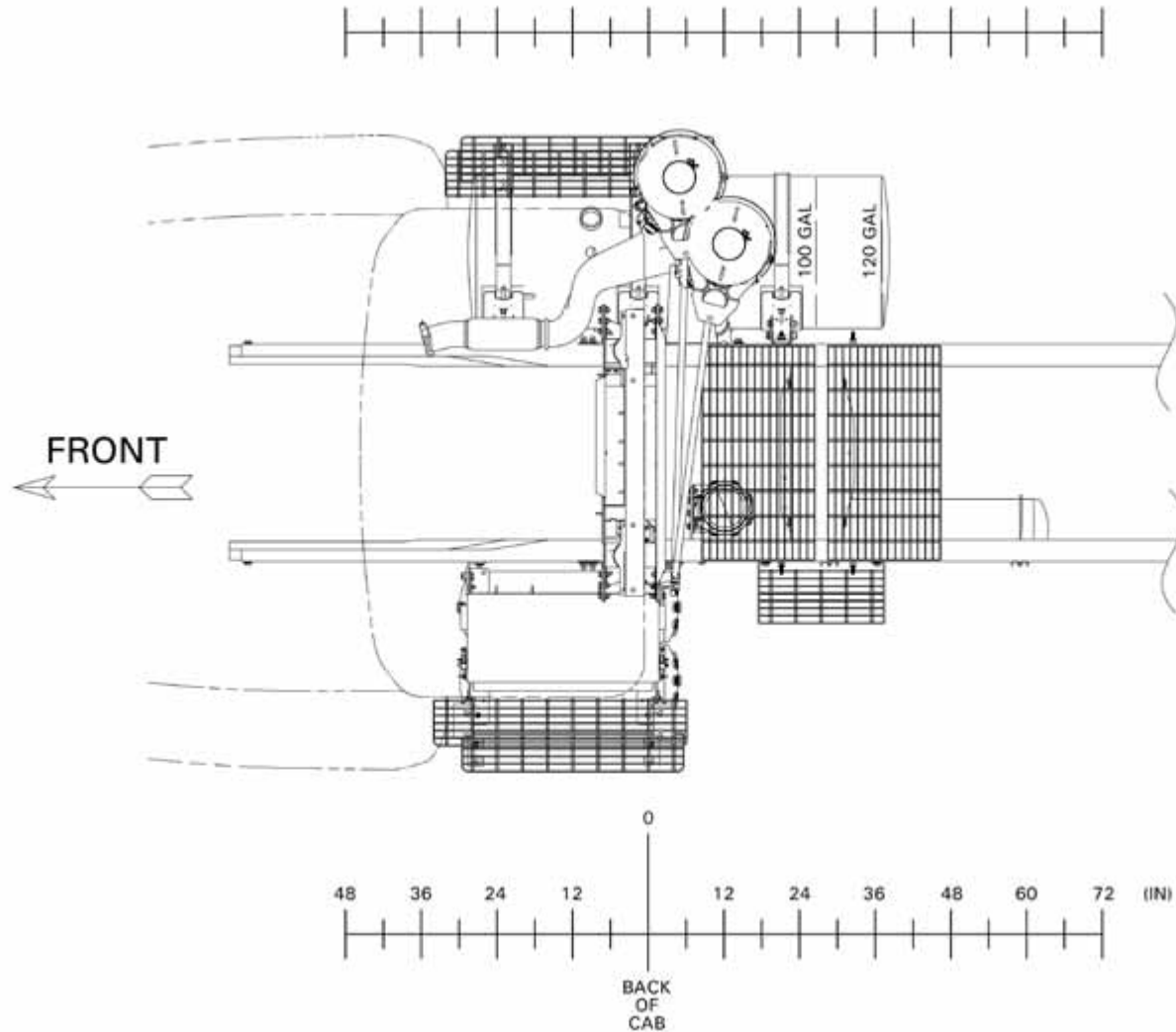

[↶ return to table of contents](#)

ALL MODEL SPECIFICATIONS

CHASSIS PACKAGING DIAGRAMS (EGR ONLY)

Model SBA 4x4 & 6x6, 100GAL 0015561-0015562, 120GAL 0015SEJ-0015SEH, Vertical/Vertical 0007BDS and 0007SCS, Aux. Air Tank 0504078, Battery Box and Air Tanks 0008WKE w/ 0504602, Transfer Case 13TJGTC

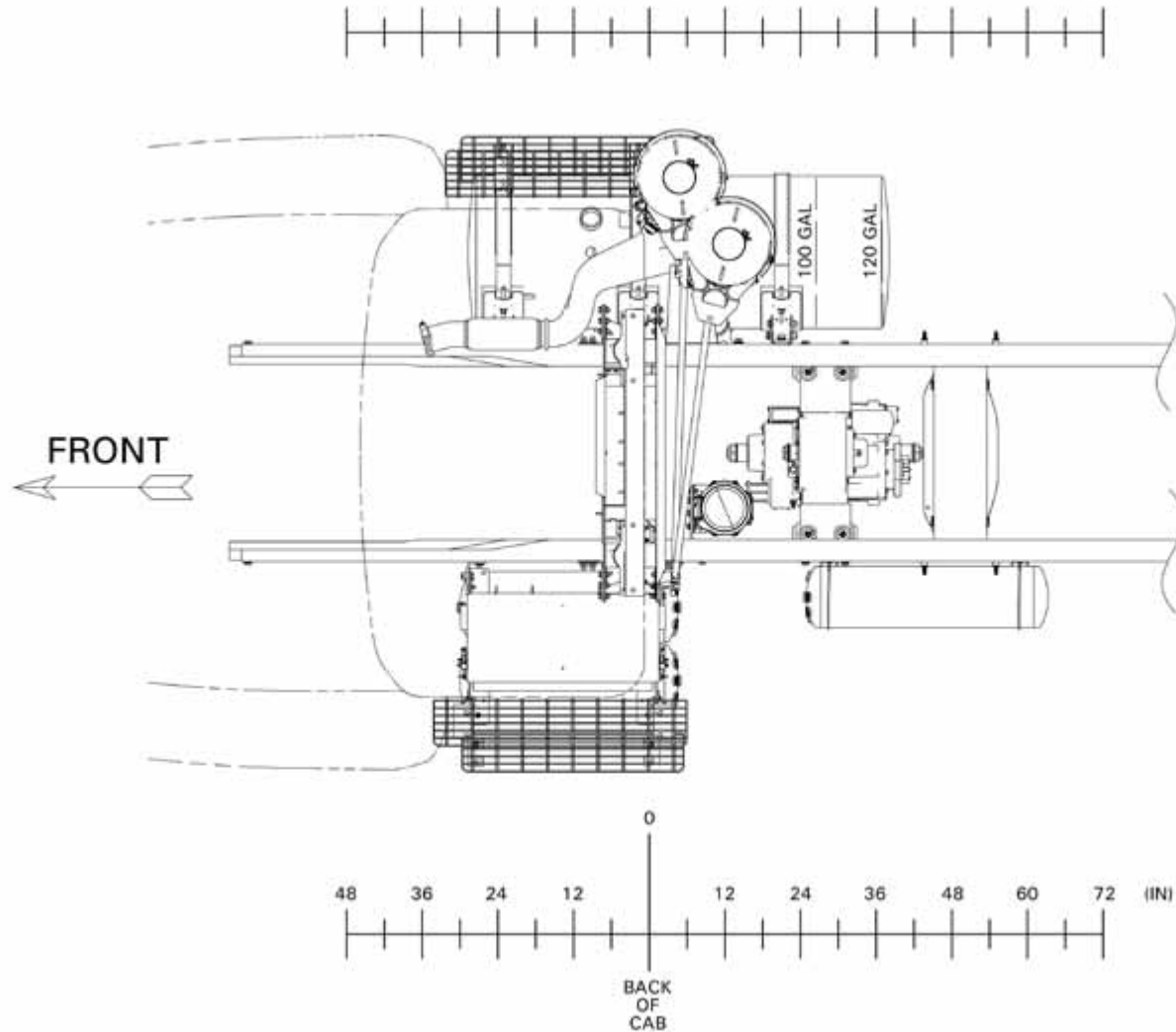

[↶ return to table of contents](#)

ALL MODEL SPECIFICATIONS

CHASSIS PACKAGING DIAGRAMS (EGR ONLY)

Model SBA 6x4 & 8x6, 60GAL 0015DWW-0015DWX, 80GAL 0015DWU-0015DWV, Vertical/Vertical 0007BDS and 0007SCS, Aux. Air Tank 0504078, Battery Box and Air Tanks 0008WKH w/ 0504628, Hydraulic Tank 0015WTN

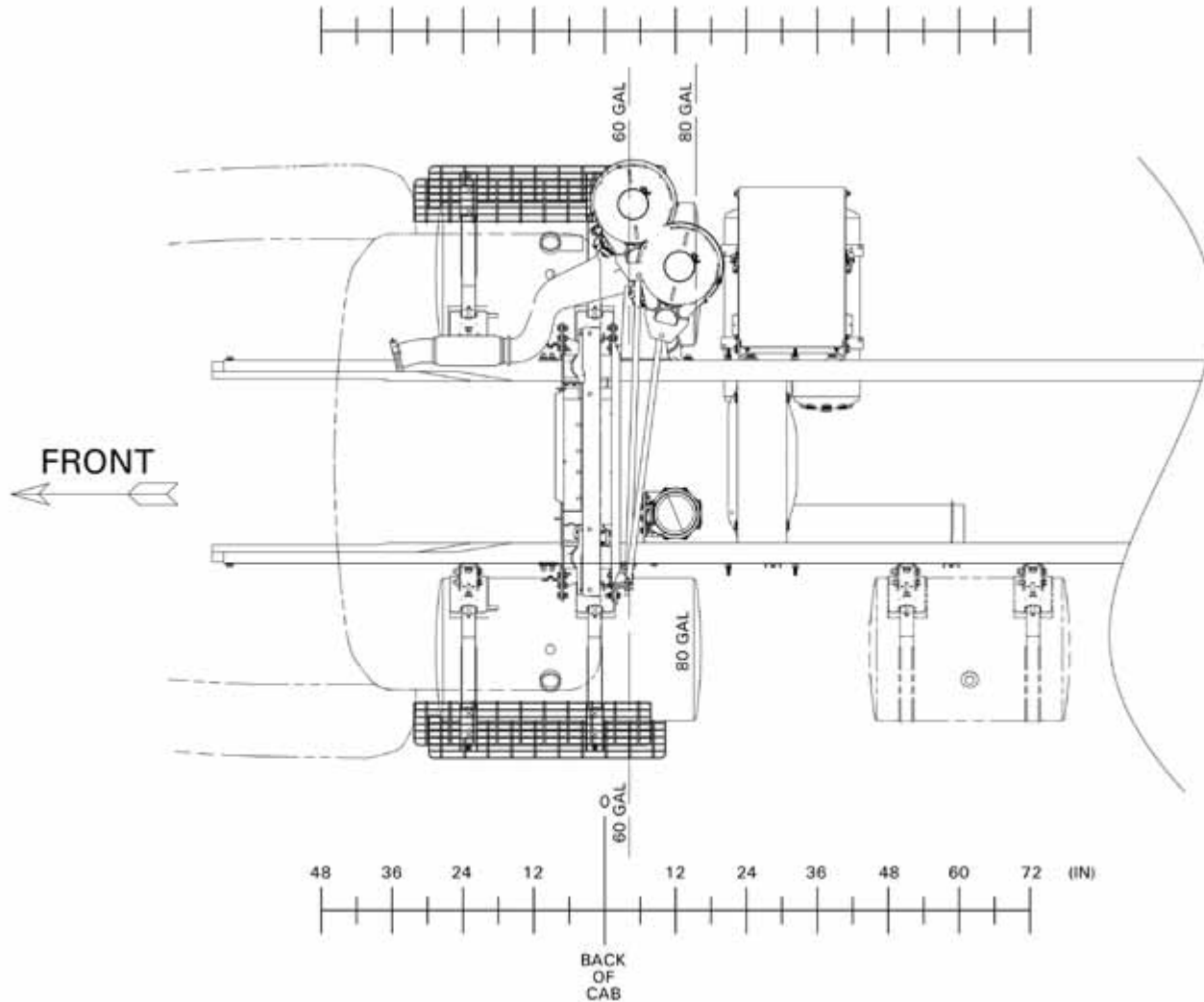

[↶ return to table of contents](#)

ALL MODEL SPECIFICATIONS

CHASSIS PACKAGING DIAGRAMS (EGR ONLY)

Model SBA 6x4 & 8x6, 60GAL 0015DWW-0015DWX, 80GAL 0015DWU-0015DWV, Vertical/Vertical 0007BDS and 0007SCS, Aux. Air Tank 0504078, Battery Box and Air Tanks 0008WKH w/ 0504628

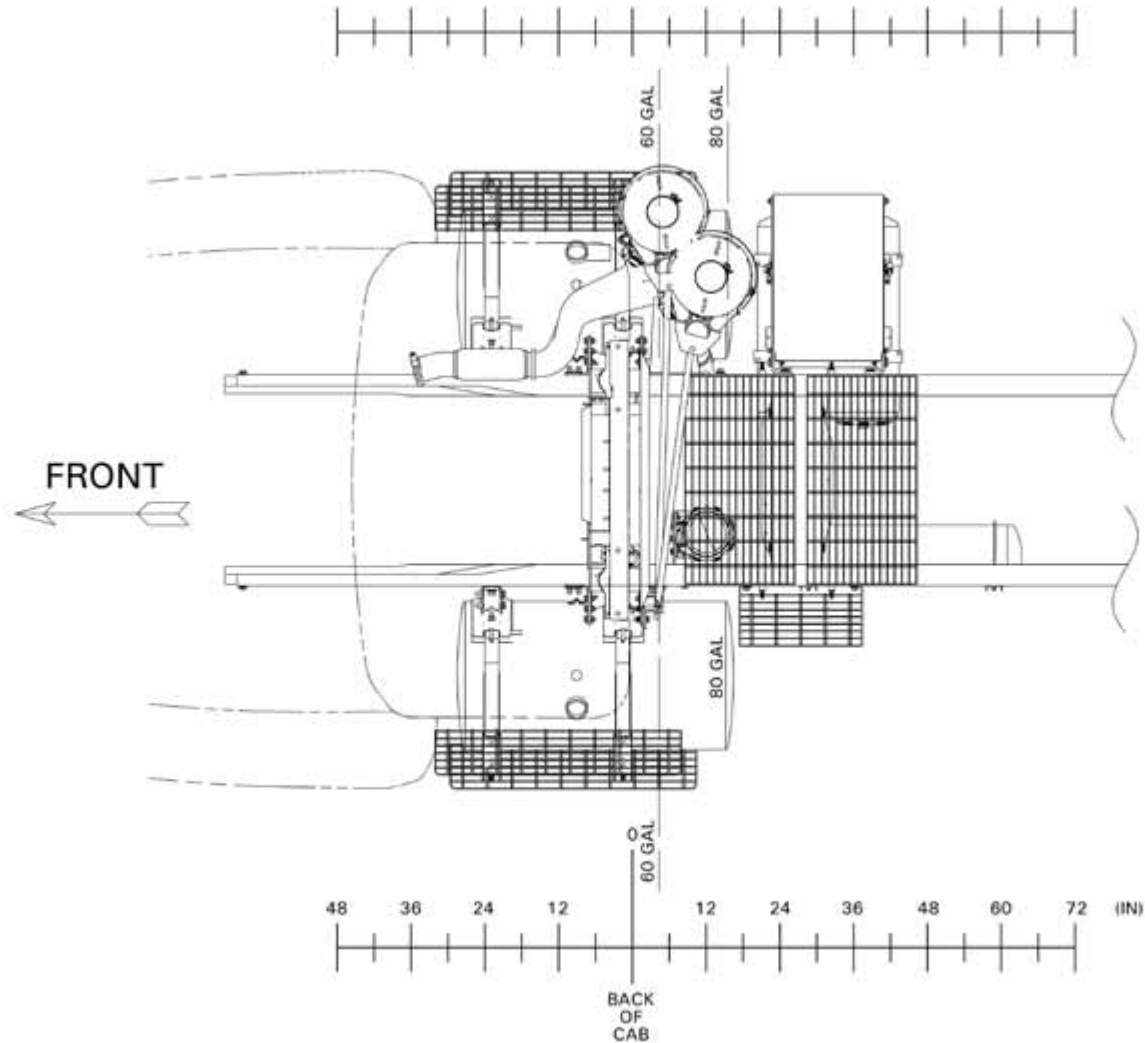

[↶ return to table of contents](#)

ALL MODEL SPECIFICATIONS

CHASSIS PACKAGING DIAGRAMS (EGR ONLY)

Model SBA 6x4 & 8x6, 100GAL 0015DWS-0015DWT, Vertical/Vertical 0007BDS and 0007SCS,
Aux. Air Tank 0504078, Battery Box and Air Tanks 0008WKH w/ 0504628, Hydraulic Tank 0015WTN

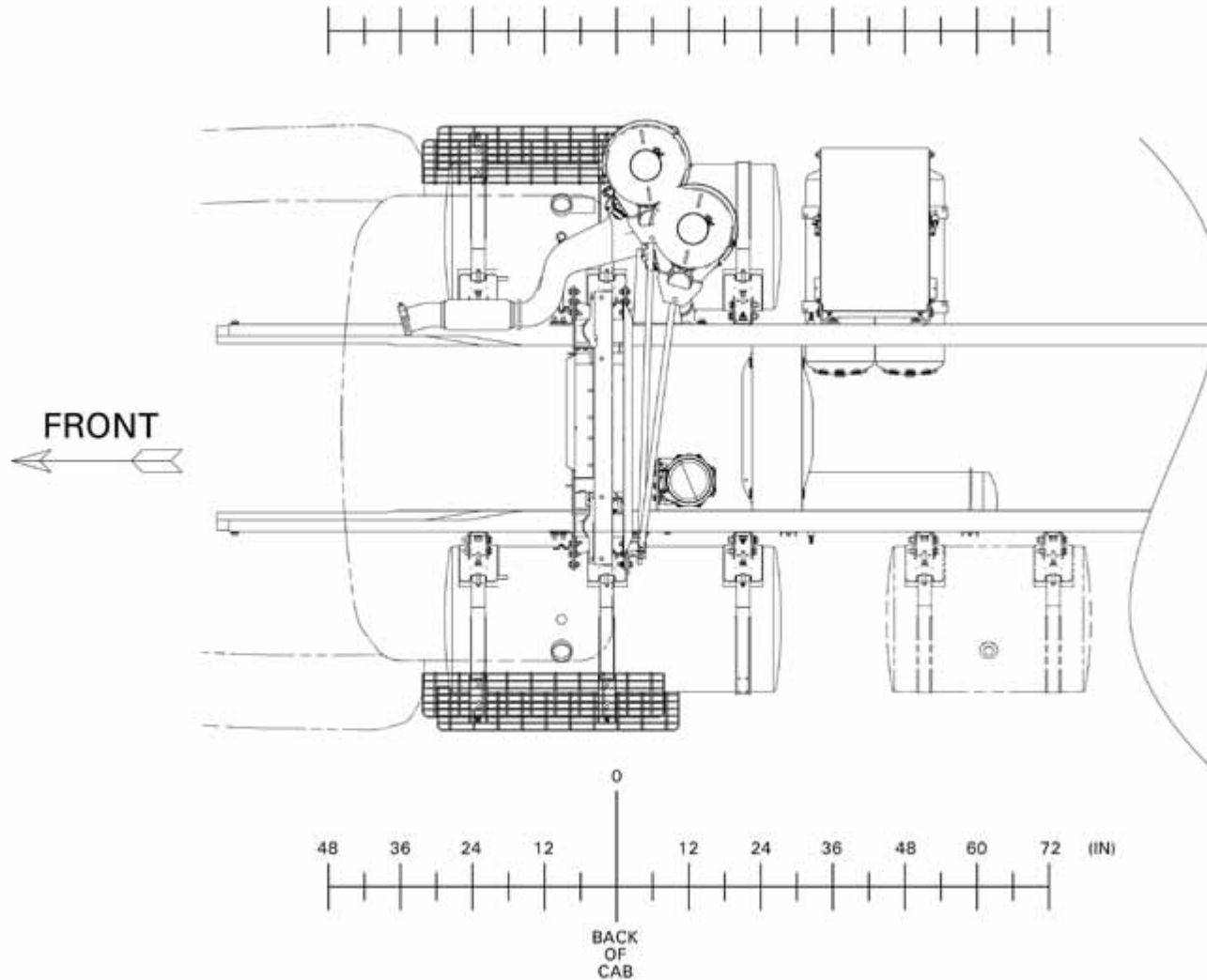

[↶ return to table of contents](#)

ALL MODEL SPECIFICATIONS

CHASSIS PACKAGING DIAGRAMS (EGR ONLY)

Model SBA 6x4 & 8x6, 100GAL 0015DWS-0015DWT, Vertical/Vertical 0007BDS and 0007SCS,
Aux. Air Tank 0504078, Battery Box and Air Tanks 0008WKH w/ 0504628

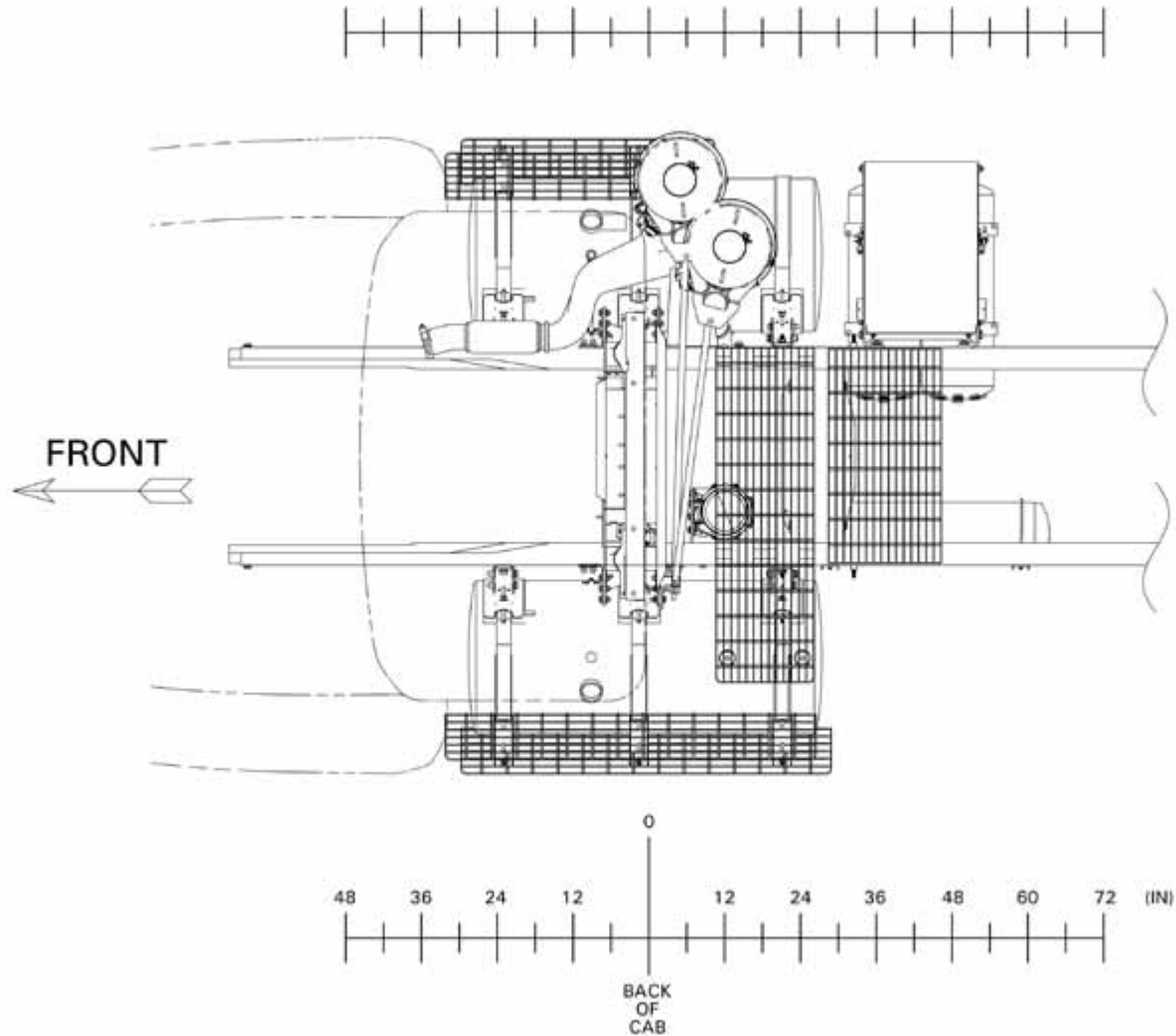

[↶ return to table of contents](#)

ALL MODEL SPECIFICATIONS

CHASSIS PACKAGING DIAGRAMS (EGR ONLY)

Model SBA 6x4 & 8x6, 120GAL 0015DWP-0015DWR, Vertical/Vertical 0007BDS and 0007SCS,
Aux. Air Tank 0504078, Battery Box and Air Tanks 0008WKH w/ 0504628, Hydraulic Tank 0015WTN

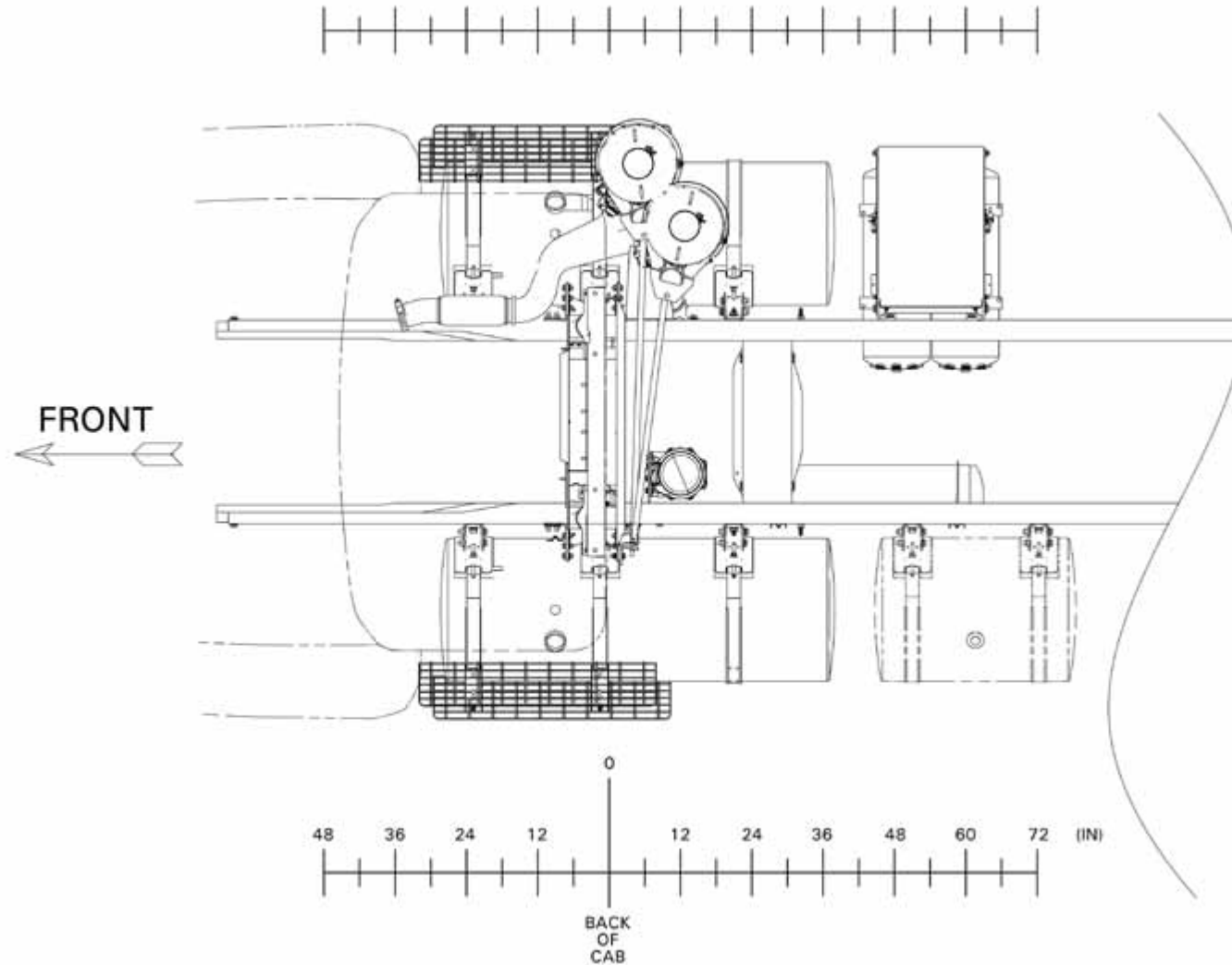

[↶ return to table of contents](#)

ALL MODEL SPECIFICATIONS

CHASSIS PACKAGING DIAGRAMS (EGR ONLY)

Model SBA 6x4 & 8x6, 120GAL 0015DWP-0015DWR, Vertical/Vertical 0007BDS or 0007BDS w/ 0007SCS,
Aux. Air Tank 0504078, Battery Box and Air Tanks 0008WKH w/ 0504628

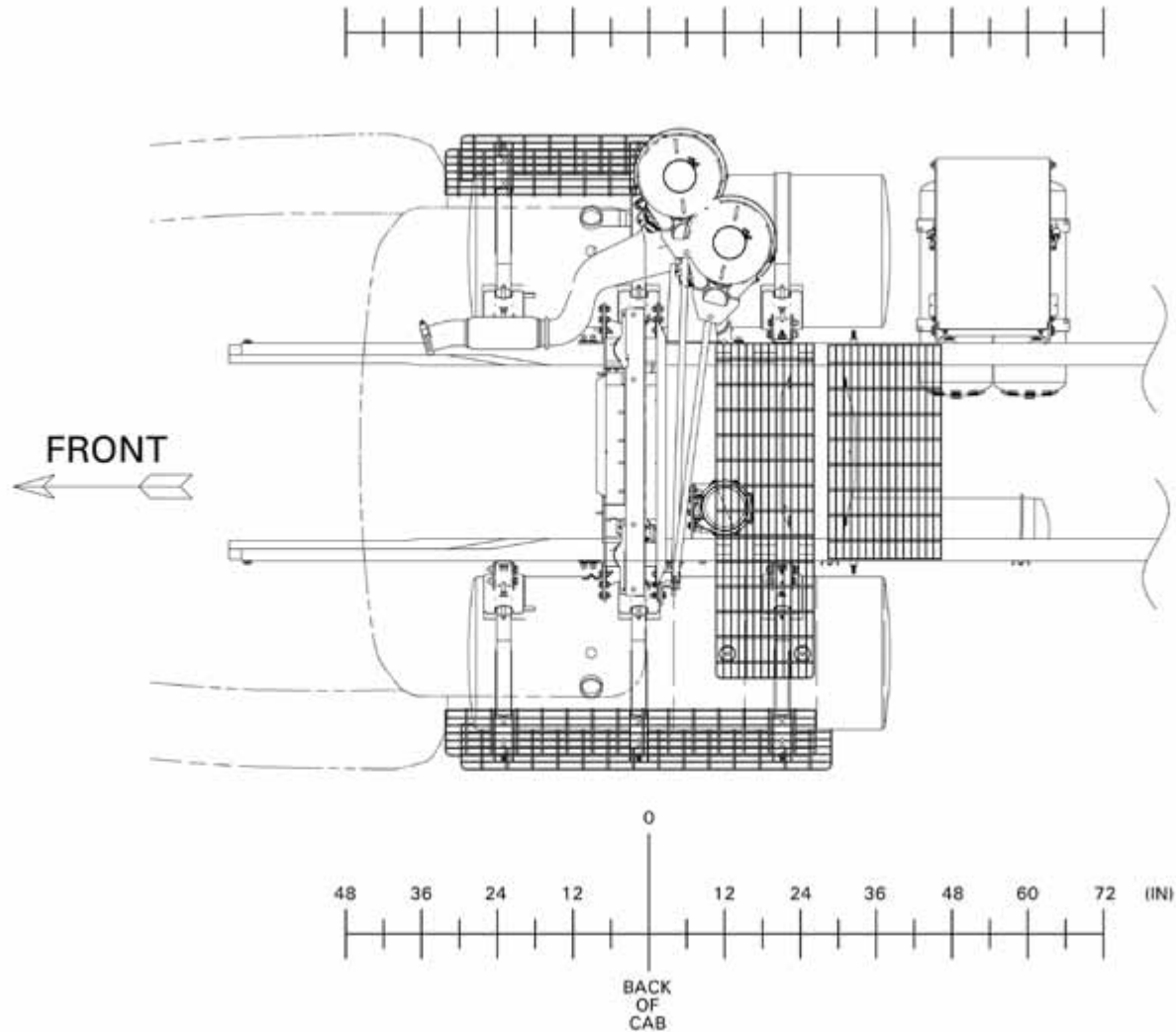

[↶ return to table of contents](#)

ALL MODEL SPECIFICATIONS

CHASSIS PACKAGING DIAGRAMS (EGR ONLY)

Model SBA 6x4 & 8x6, 60GAL 0015SSN-0015SSM, 80GAL 0015SGL-0015SSL, Horizontal/Vertical 0007BJC, Aux. Air Tank 0504078, Battery Box 0008WKH, Air Tanks 0504013, Hydraulic Tank 0015WTN

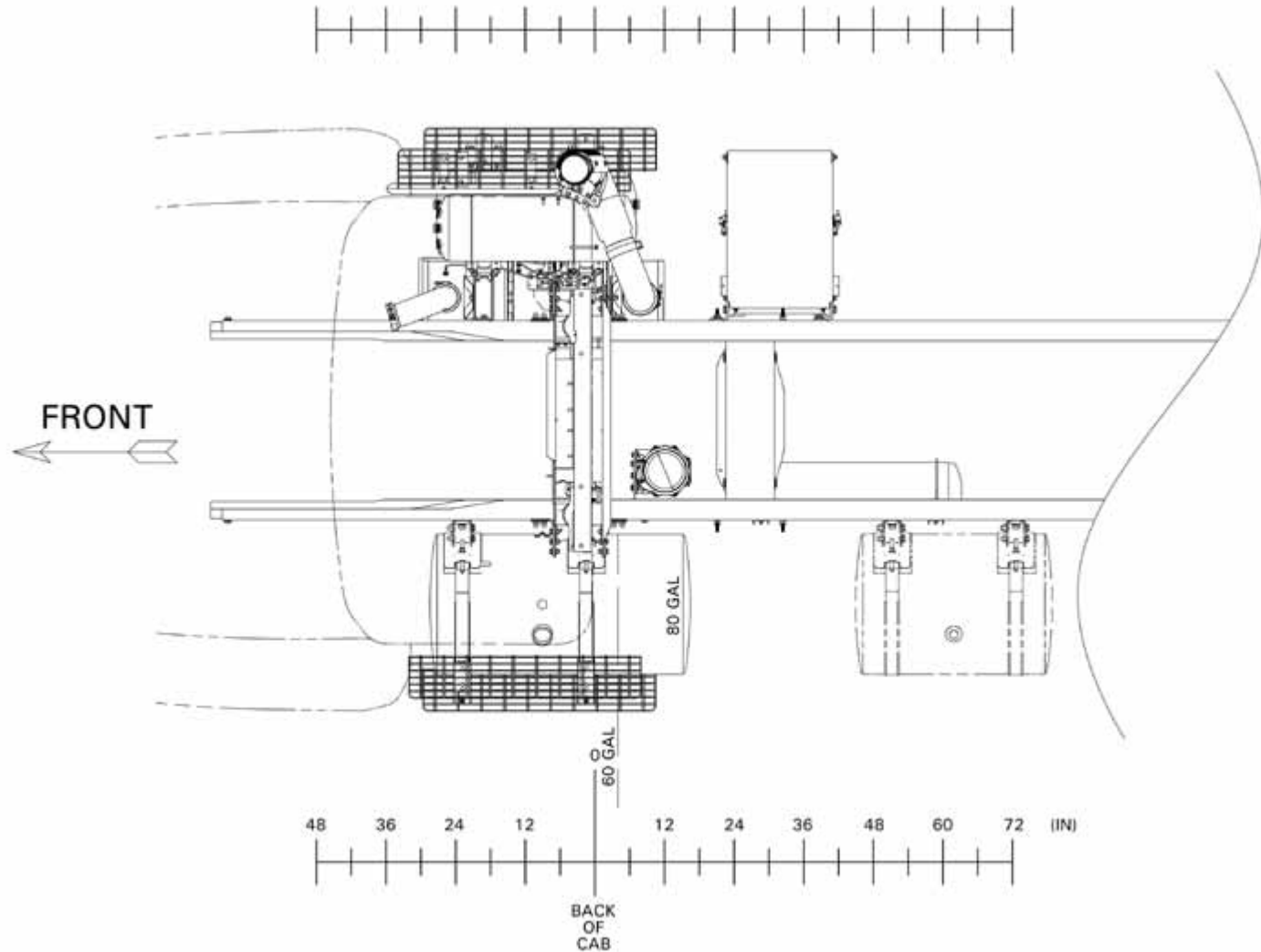

[↶ return to table of contents](#)

ALL MODEL SPECIFICATIONS

CHASSIS PACKAGING DIAGRAMS (EGR ONLY)

Model SBA 6x4 & 8x6, 60GAL 0015SSN-0015SSM, 80GAL 0015SGL-0015SSL, Horizontal/Vertical 0007BJC, Aux. Air Tank 0504078, Battery Box 0008WKH, Air Tanks 0504013

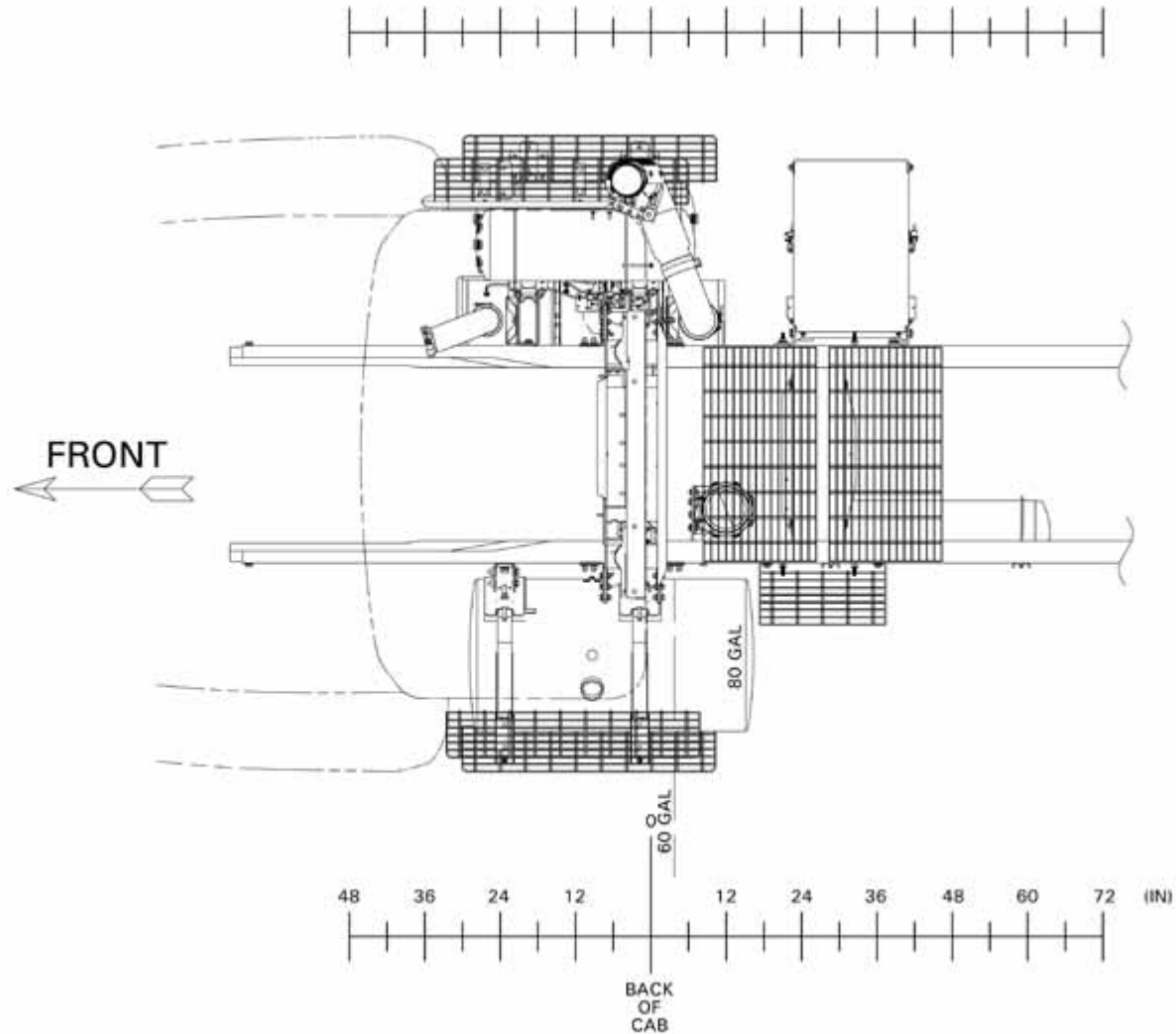

[↶ return to table of contents](#)

ALL MODEL SPECIFICATIONS

CHASSIS PACKAGING DIAGRAMS (EGR ONLY)

Model SBA 6x4 & 8x6, 60GAL 0015SSN-0015SSM, 80GAL 0015SGL-0015SSL, Horizontal/Vertical 0007BJC, Aux. Air Tank 0504078, Battery Box 0008WKH, Air Tanks 0504013, Transfer Case 13TJGTC

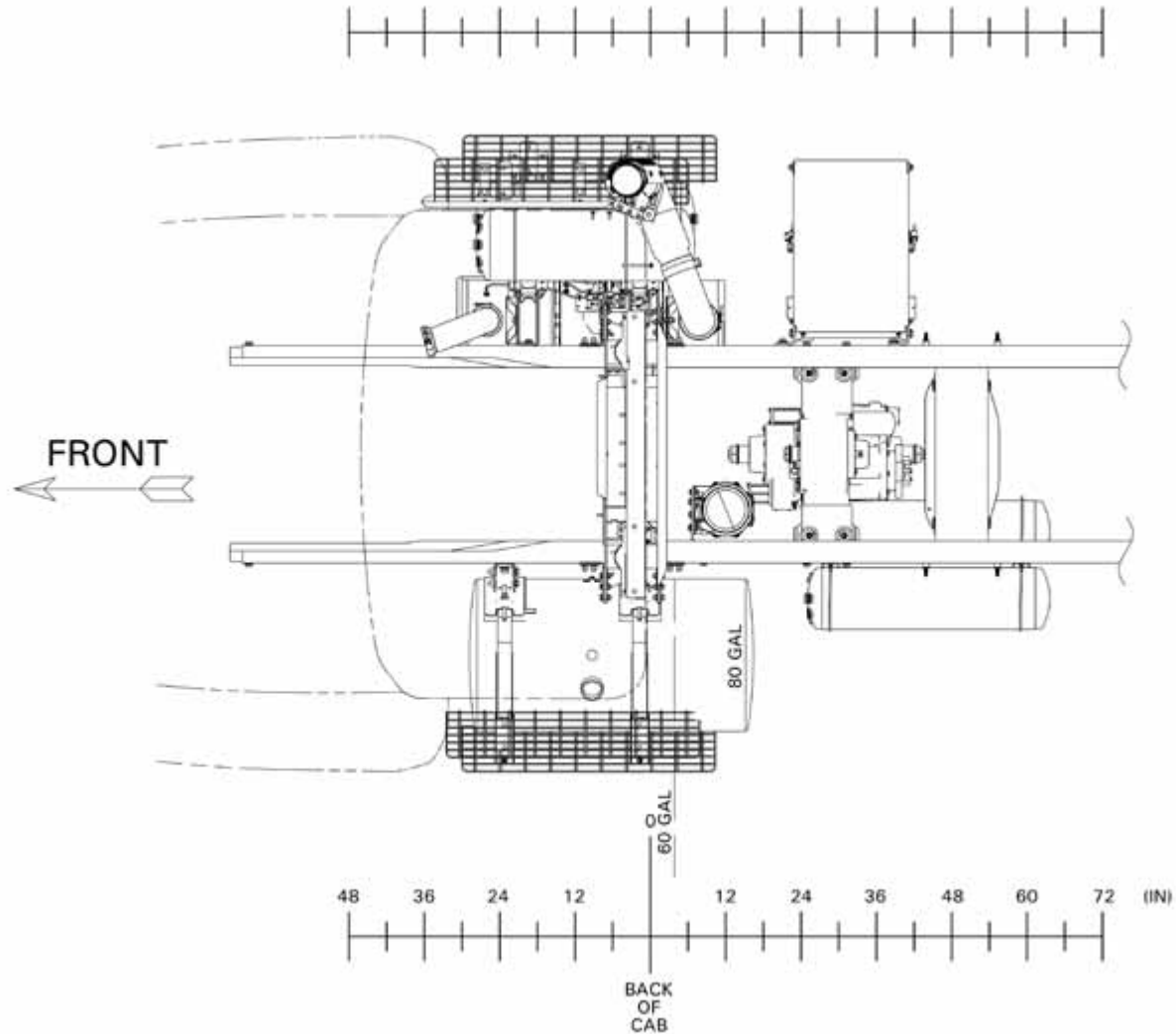

[↶ return to table of contents](#)

ALL MODEL SPECIFICATIONS

CHASSIS PACKAGING DIAGRAMS (EGR ONLY)

Model SBA 6x4 & 8x6, 100GAL 0015SHC-0015SSK, 120GAL 0015SMZ-0015SSG, Horizontal/Vertical 0007BJC, Aux. Air Tank 0504078, Battery Box 0008WKH, Air Tanks 0504013, Hydraulic Tank 0015WTN

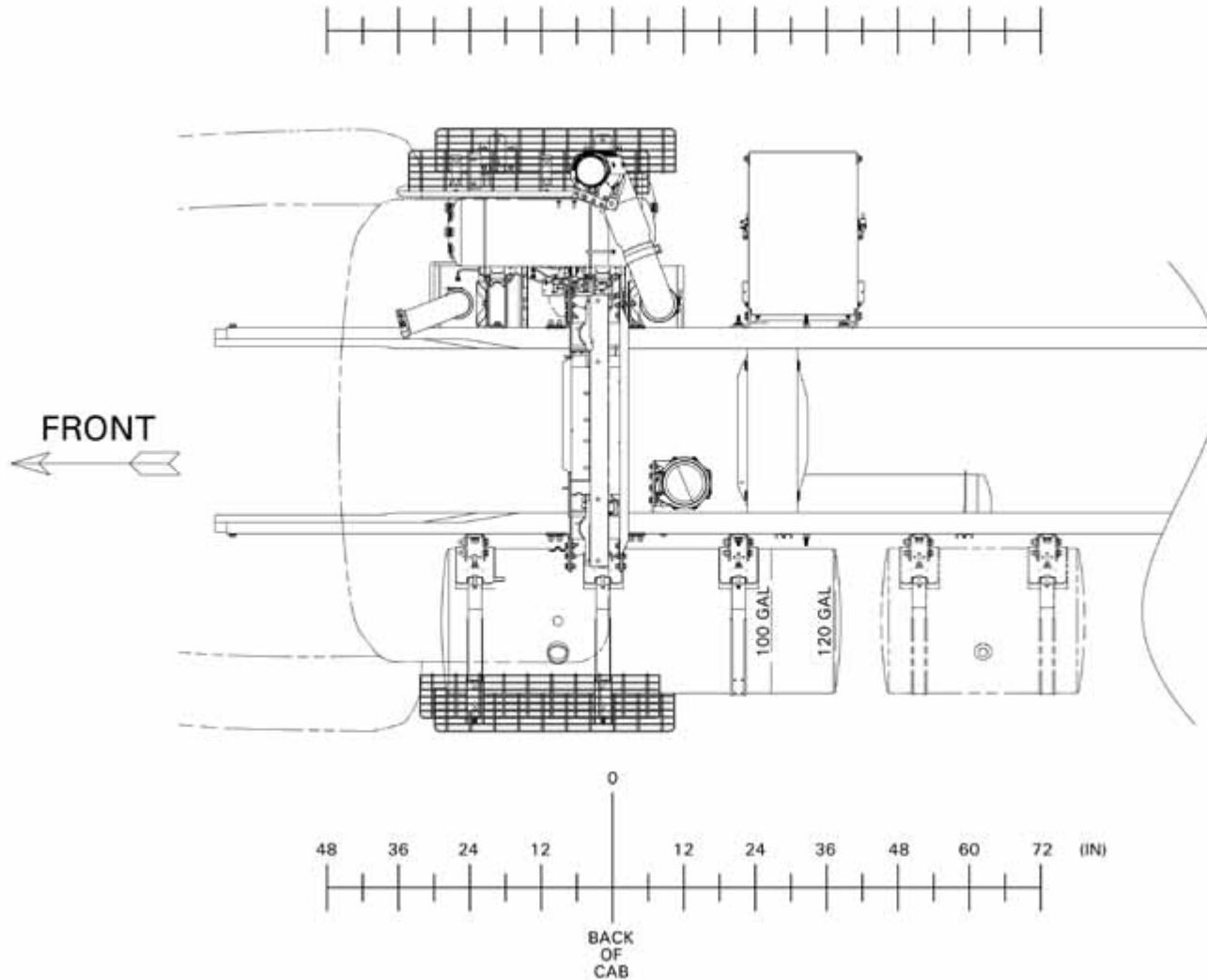

[↶ return to table of contents](#)

ALL MODEL SPECIFICATIONS

CHASSIS PACKAGING DIAGRAMS (EGR ONLY)

Model SBA 6x4 & 8x6, 100GAL 0015SHC-0015SSK, 120GAL 0015SMZ-0015SSG, Horizontal/Vertical 0007BJC, Aux. Air Tank 0504078, Battery Box 0008WKH, Air Tanks 0504013

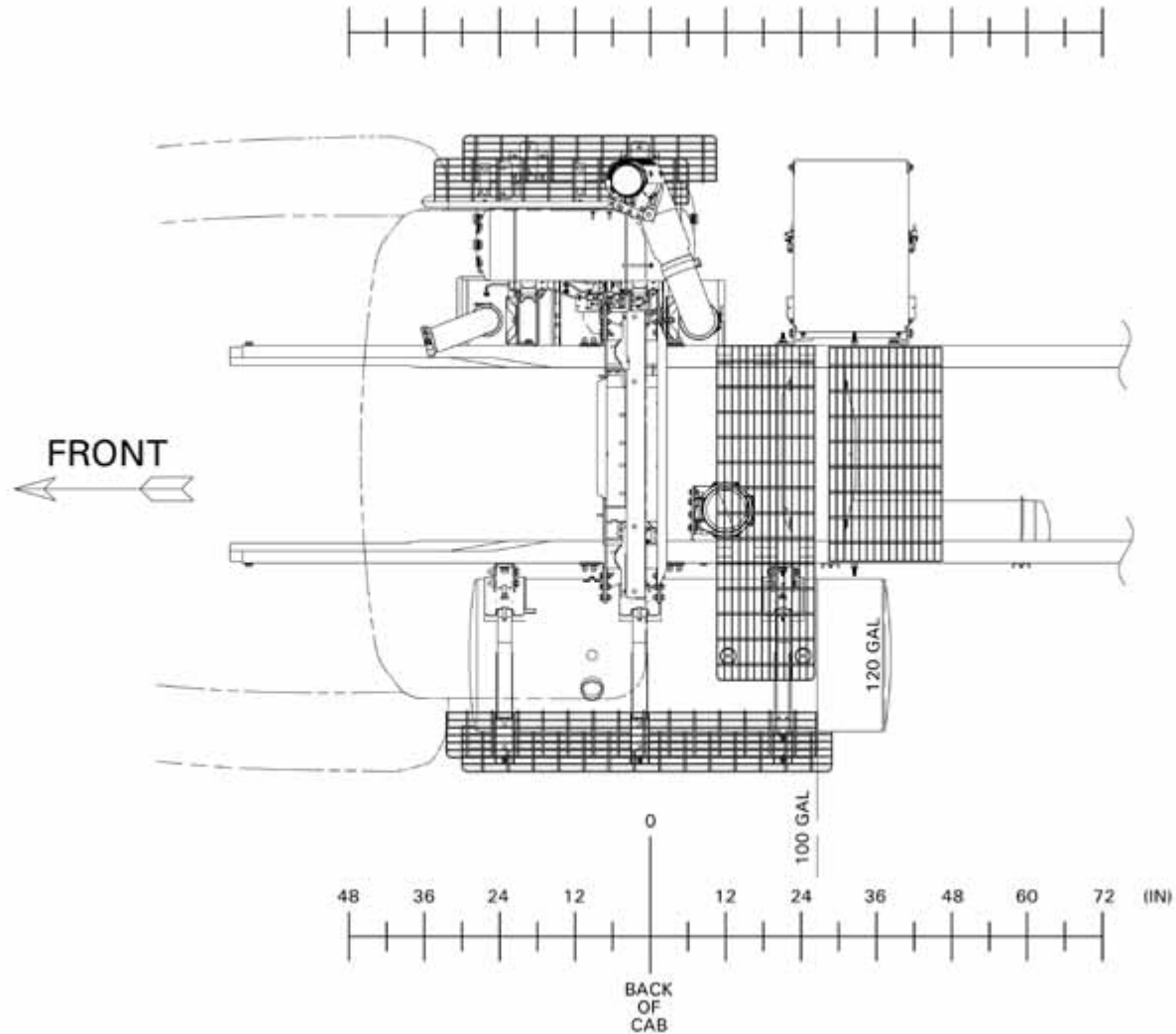

[↶ return to table of contents](#)

ALL MODEL SPECIFICATIONS

CHASSIS PACKAGING DIAGRAMS (EGR ONLY)

Model SBA 4x4 & 6x6, 100GAL 0015SHC-0015SSK, 120GAL 0015SMZ-0015SSG, Horizontal/Vertical 0007BJC, Battery Box 0008WKH, Air Tanks 0504013, Transfer Case 13TJGTC

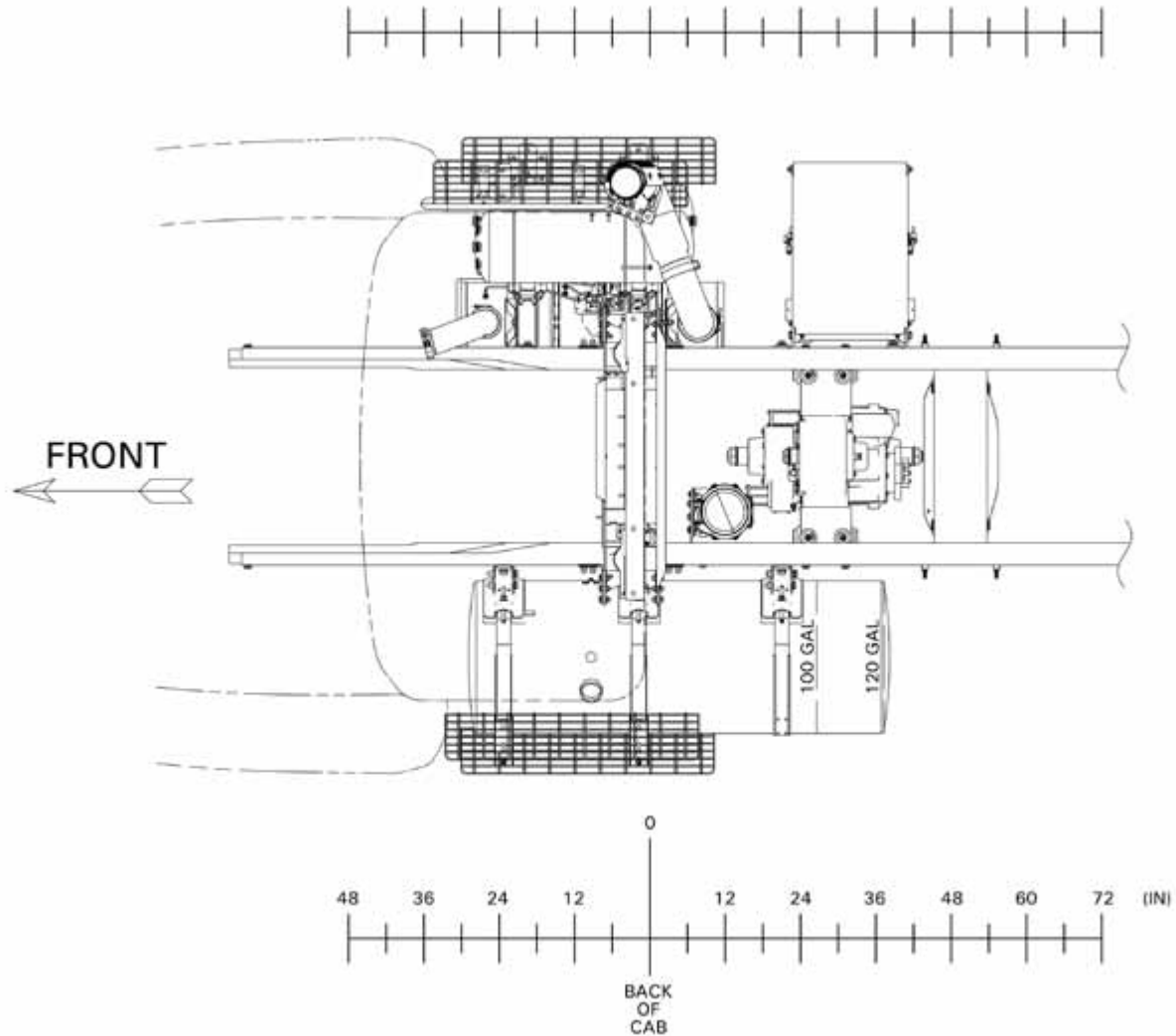

[↶ return to table of contents](#)

ALL MODEL SPECIFICATIONS

CHASSIS PACKAGING DIAGRAMS (EGR ONLY)

Model SBA 6x4 & 8x6, 60GAL 0015SSN-0015SSM, 80GAL 0015SGL-0015SSL, Horizontal/Vertical 0007DHJ,
Aux. Air Tank 0504078, Battery Box 0008WKH, Air Tanks 0504013, Hydraulic Tank 0015WTN

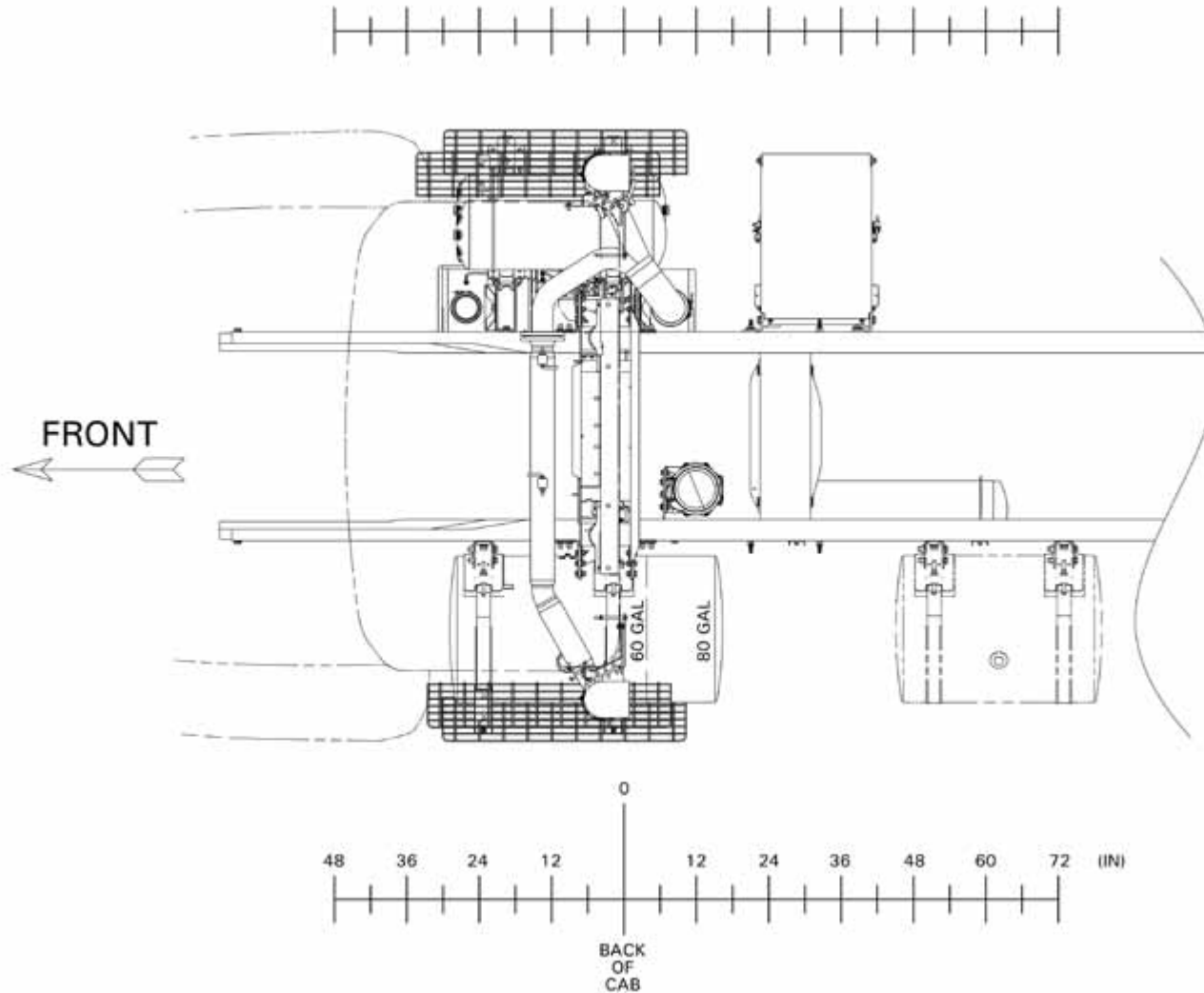

[↶ return to table of contents](#)

ALL MODEL SPECIFICATIONS

CHASSIS PACKAGING DIAGRAMS (EGR ONLY)

Model SBA 6x4 & 8x6, 60GAL 0015SSN-0015SSM, 80GAL 0015SGL-0015SSL, Horizontal/Vertical 0007DHJ,
Aux. Air Tank 0504078, Battery Box 0008WKH, Air Tanks 0504013

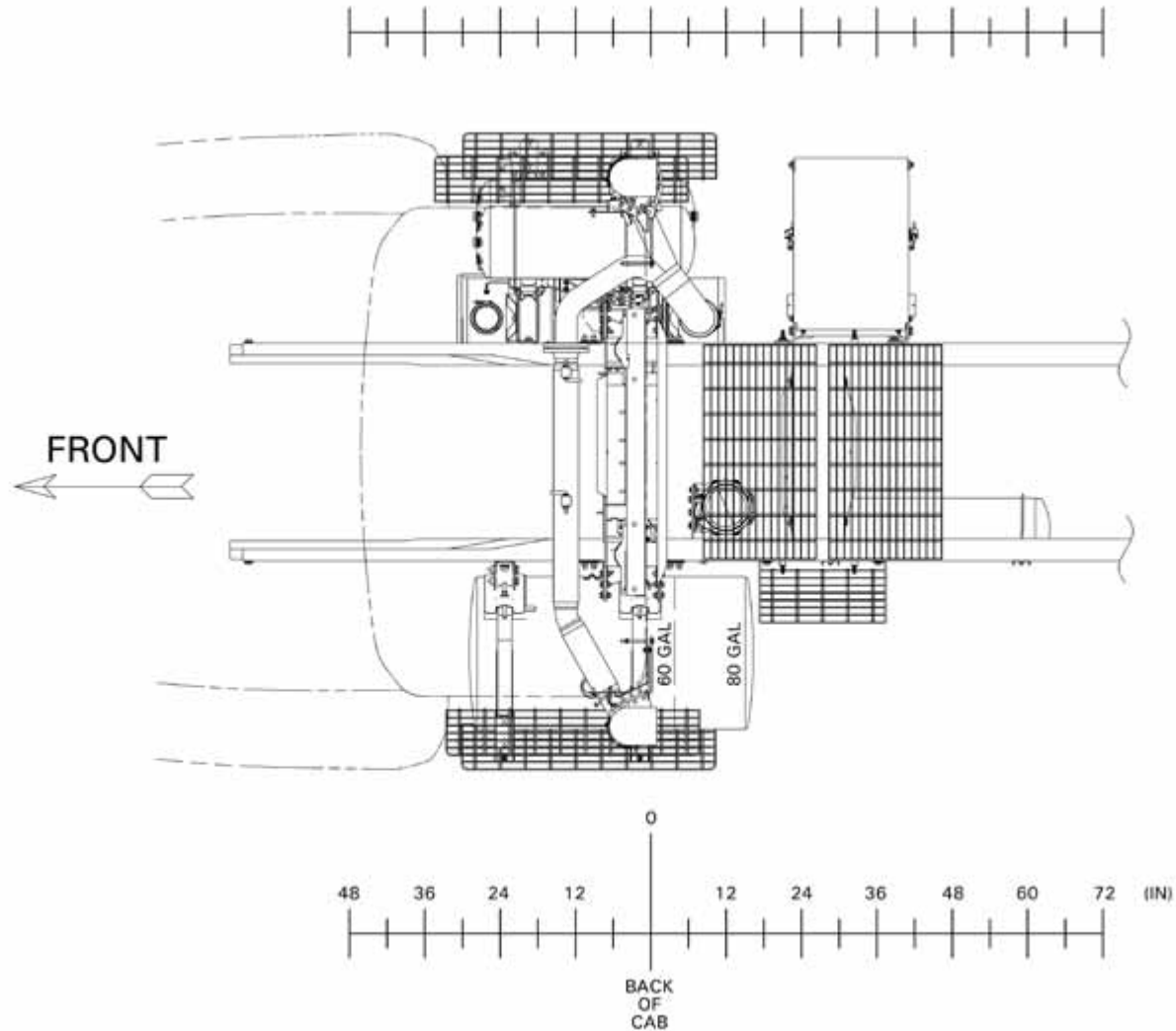

[↶ return to table of contents](#)

ALL MODEL SPECIFICATIONS

CHASSIS PACKAGING DIAGRAMS (EGR ONLY)

Model SBA 6x4 & 8x6, 100GAL 0015SHC-0015SSK, 120GAL 0015SMZ-0015SSG, Horizontal/Vertical 0007DHJ, Aux. Air Tank 0504078, Battery Box 0008WKH, Air Tanks 0504013, Hydraulic Tank 0015WTN

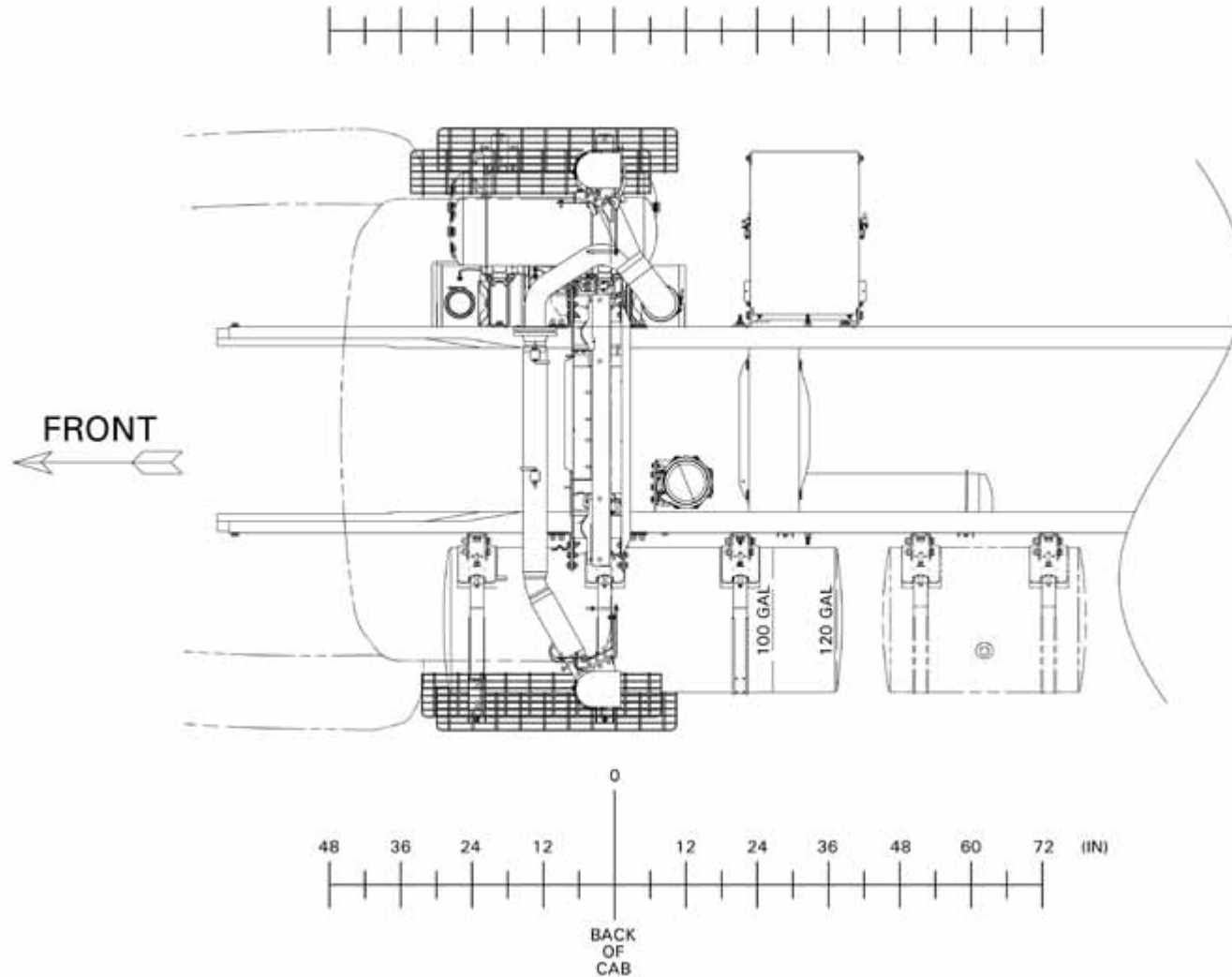

[↶ return to table of contents](#)

ALL MODEL SPECIFICATIONS

CHASSIS PACKAGING DIAGRAMS (EGR ONLY)

Model SBA 6x4 & 8x6, 100GAL 0015SHC-0015SSK, 120GAL 0015SMZ-0015SSG, Horizontal/Vertical 0007DHJ, Aux. Air Tank 0504078, Battery Box 0008WKH, Air Tanks 0504013

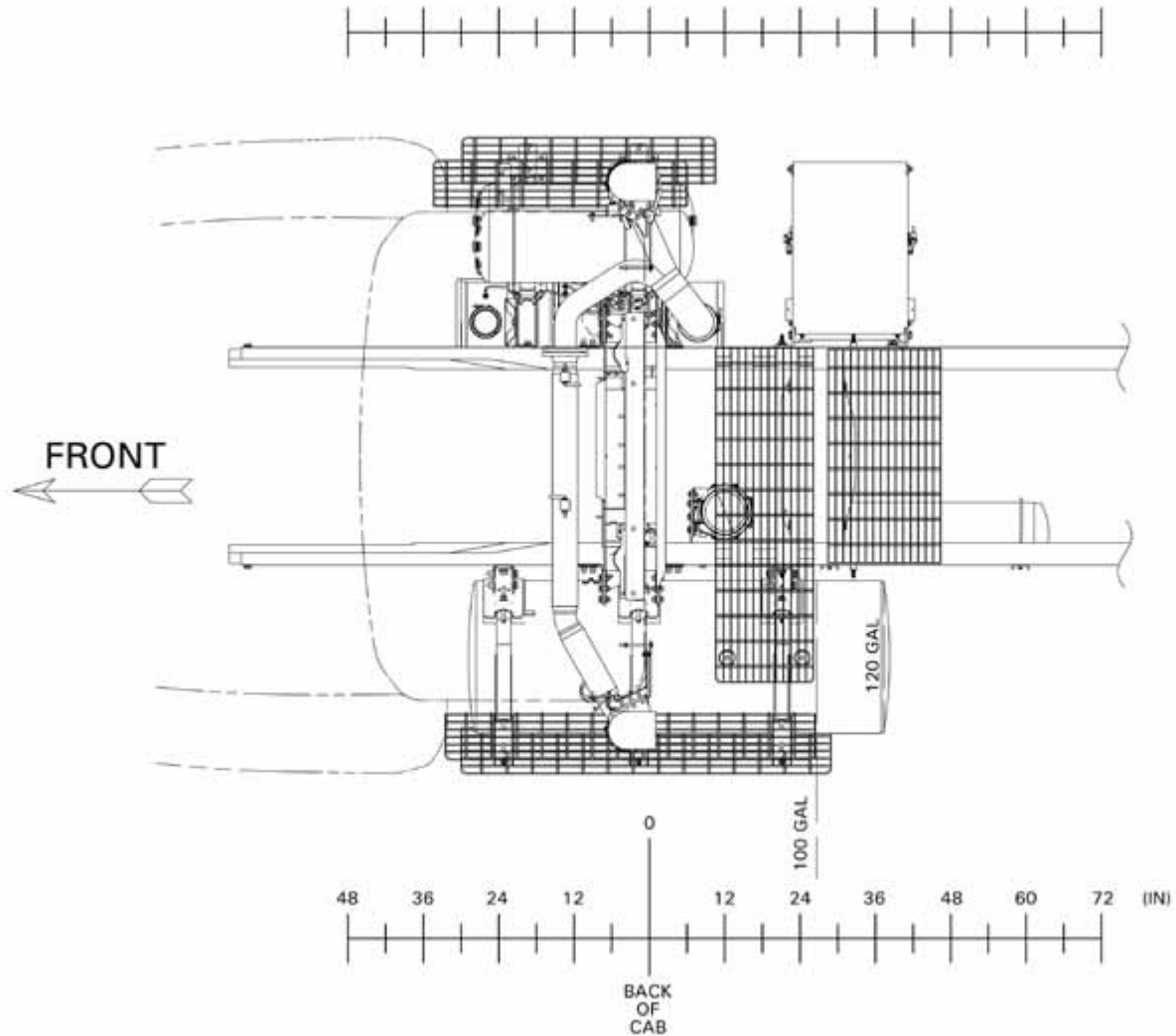

[↶ return to table of contents](#)

ALL MODEL SPECIFICATIONS

CHASSIS PACKAGING DIAGRAMS (SCR ONLY)

Model SBA 6x4 & 8x6, 80GAL 0015SGL-0015SJZ, 9.5 U.S. Gal DEF 0015DYP, Switch Back Horizontal/Single Vertical 0007BJU, Battery Box 0008VUK, Air Tanks 0504628

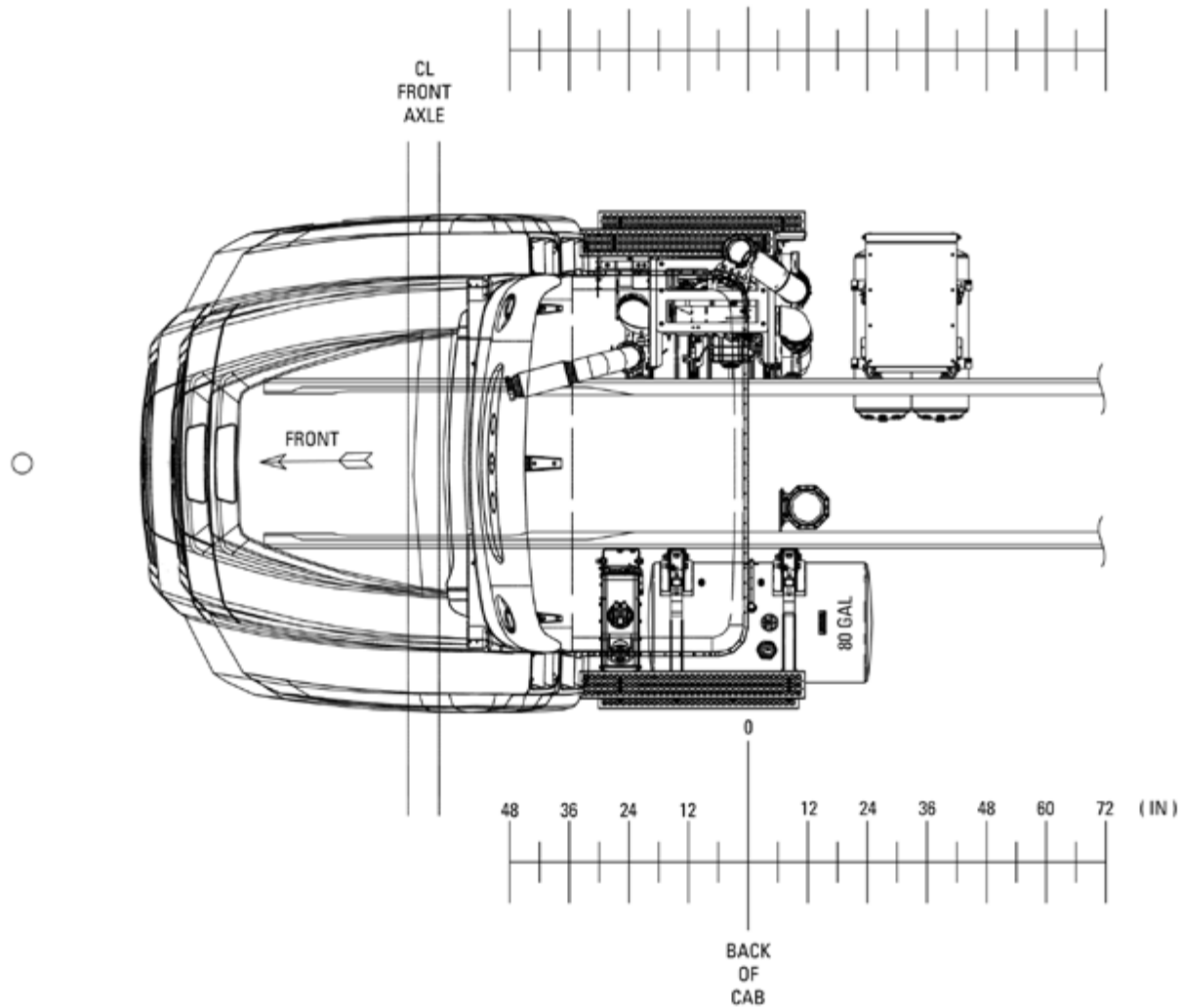

[↶ return to table of contents](#)

ALL MODEL SPECIFICATIONS

CHASSIS PACKAGING DIAGRAMS (SCR ONLY)

Model SBA 6x4 & 8x6, 100 GAL 0015SHC-0015SSK, 9.5 U.S. Gal DEF 0015DYP, Switch Back Horizontal/Single Vertical 0007BJU, Battery Box 0008VUK, Air Tanks 0504628

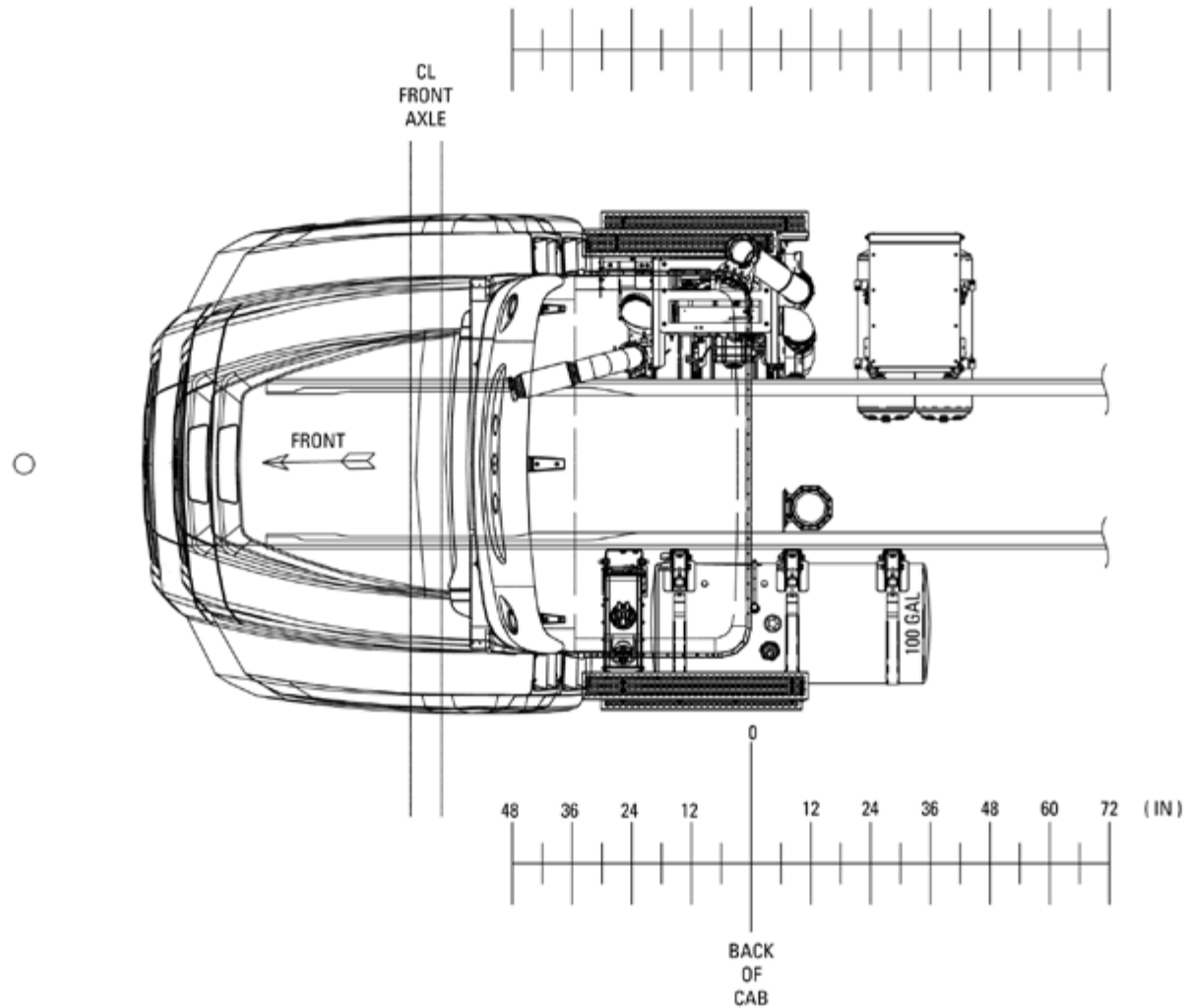

[↶ return to table of contents](#)

ALL MODEL SPECIFICATIONS

CHASSIS PACKAGING DIAGRAMS (SCR ONLY)

Model SBA 6x4 & 8x6, 120GAL 0015SMZ-0015SSG, 9.5 U.S. Gal DEF 0015DYP, Switch Back Horizontal/Single Vertical 0007BJU, Battery Box 0008VUK, Air Tanks 0504628

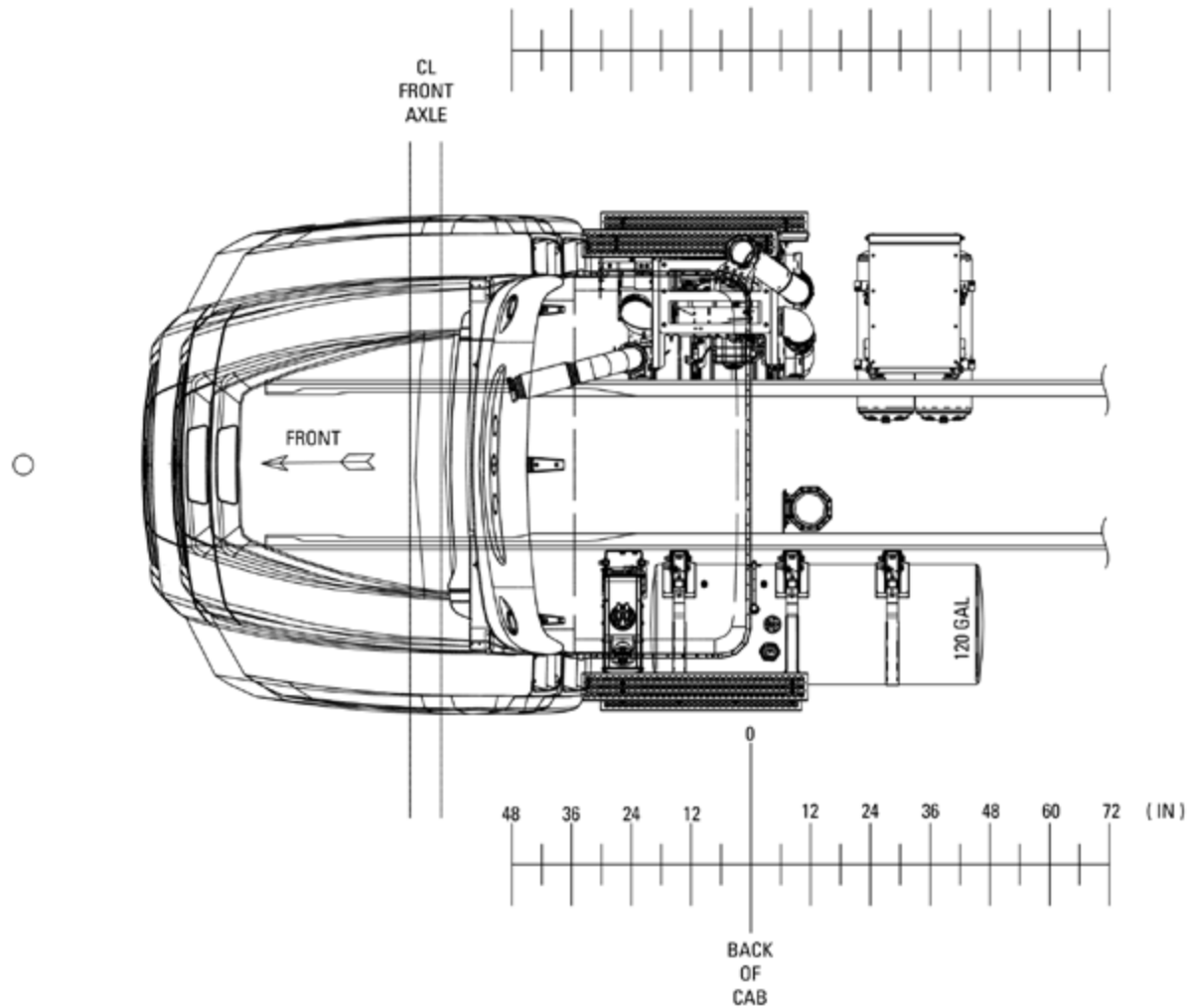

[↶ return to table of contents](#)

ALL MODEL SPECIFICATIONS

CHASSIS PACKAGING DIAGRAMS (SCR ONLY)

Model SBA 6x4 & 8x6, 80GAL 0015SGL-0015SJZ, 9.5 U.S. Gal DEF 0015DYP, Switch Back Horizontal/Dual Vertical 0007DXM, Battery Box 0008VUK, Air Tanks 0504628

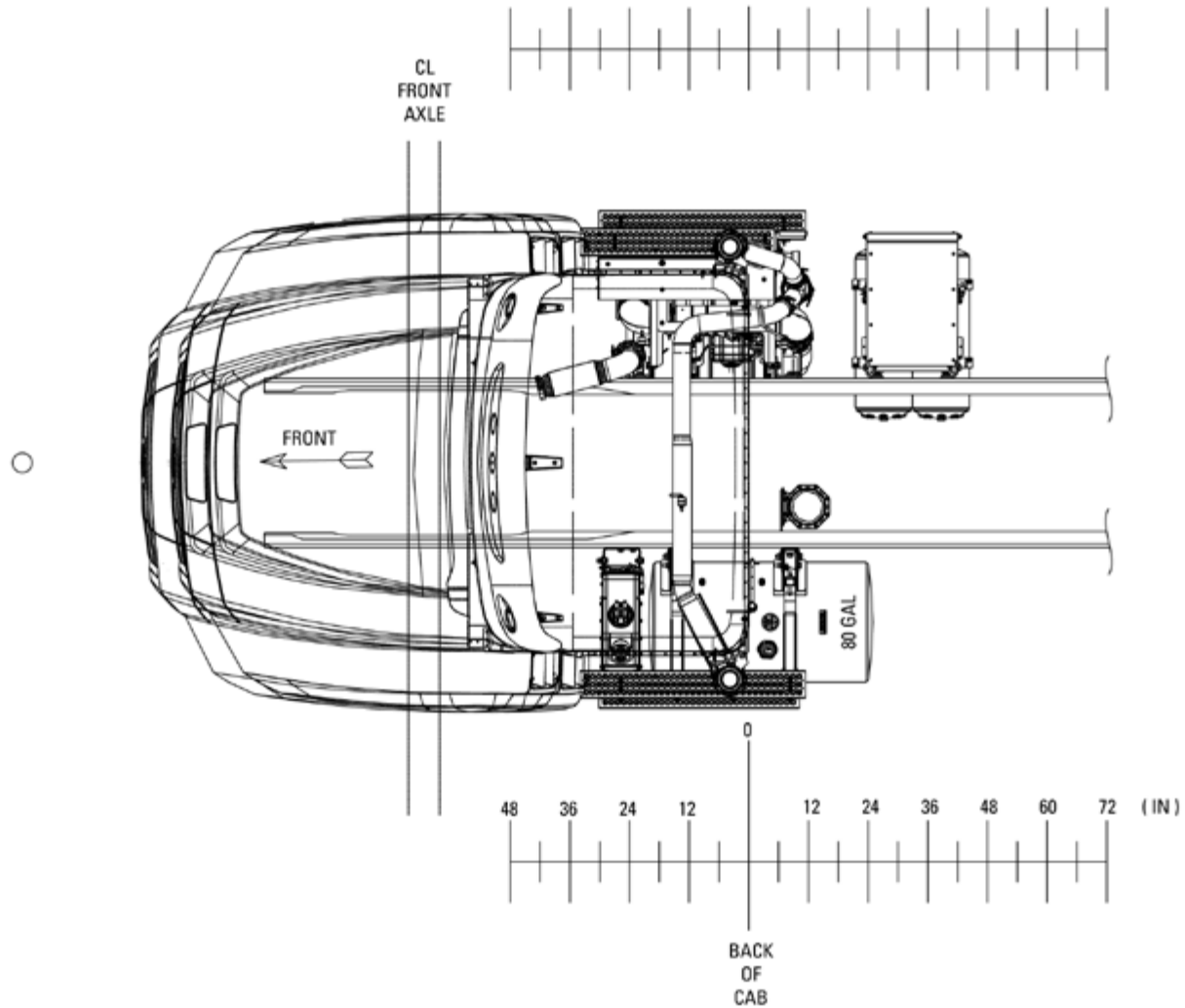

[↶ return to table of contents](#)

ALL MODEL SPECIFICATIONS

CHASSIS PACKAGING DIAGRAMS (SCR ONLY)

Model SBA 6x4 & 8x6, 100 GAL 0015SHC-0015SSK, 9.5 U.S. Gal DEF 0015DYP, Switch Back Horizontal/Dual Vertical 0007DXM, Battery Box 0008VUK, Air Tanks 0504628

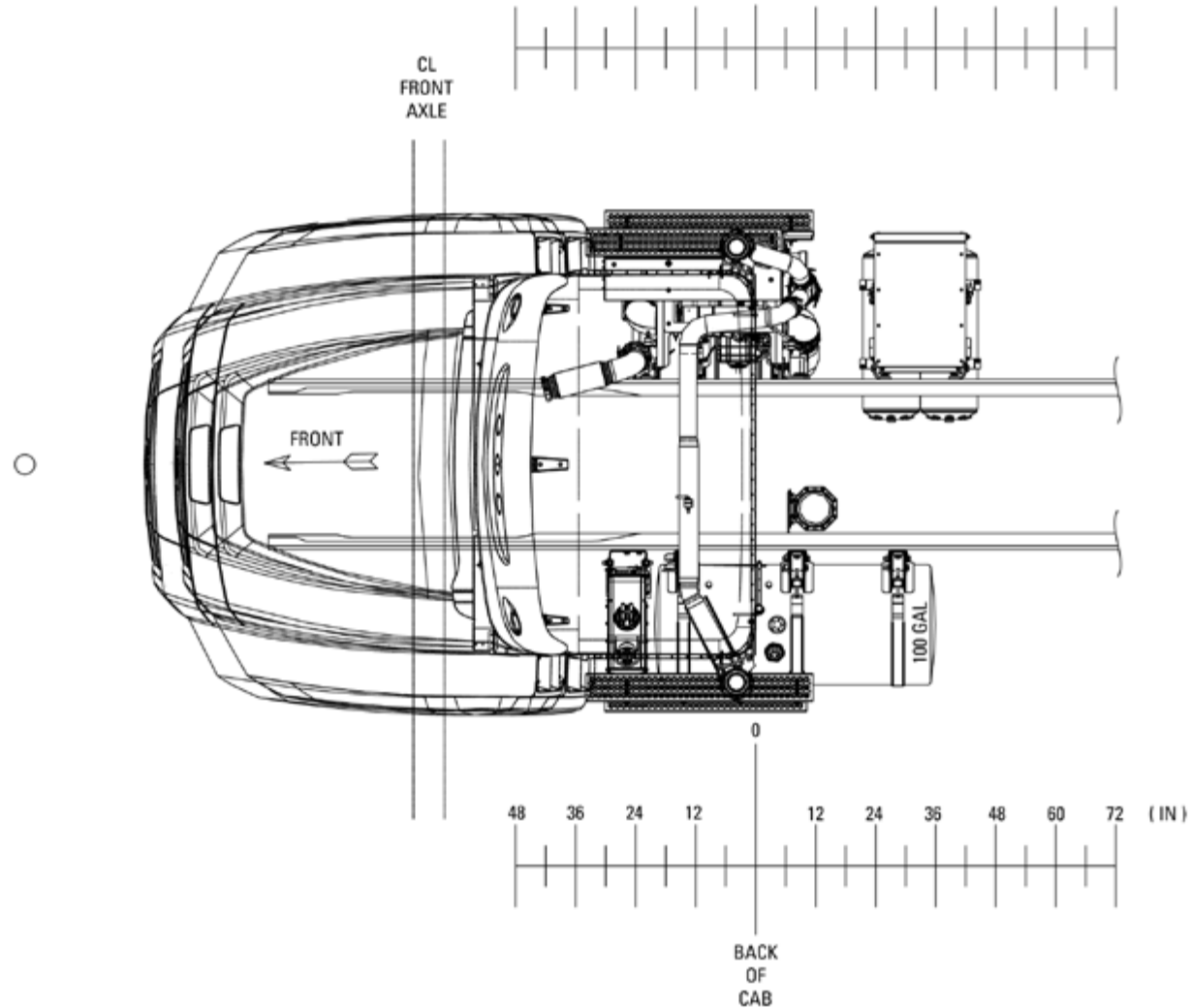

[↶ return to table of contents](#)

ALL MODEL SPECIFICATIONS

CHASSIS PACKAGING DIAGRAMS (SCR ONLY)

Model SBA 6x4 & 8x6, 120 GAL 0015SMZ-0015SSG, 9.5 U.S. Gal DEF 0015DYP, Switch Back Horizontal/Dual Vertical 0007DXM, Battery Box 0008VUK, Air Tanks 0504628

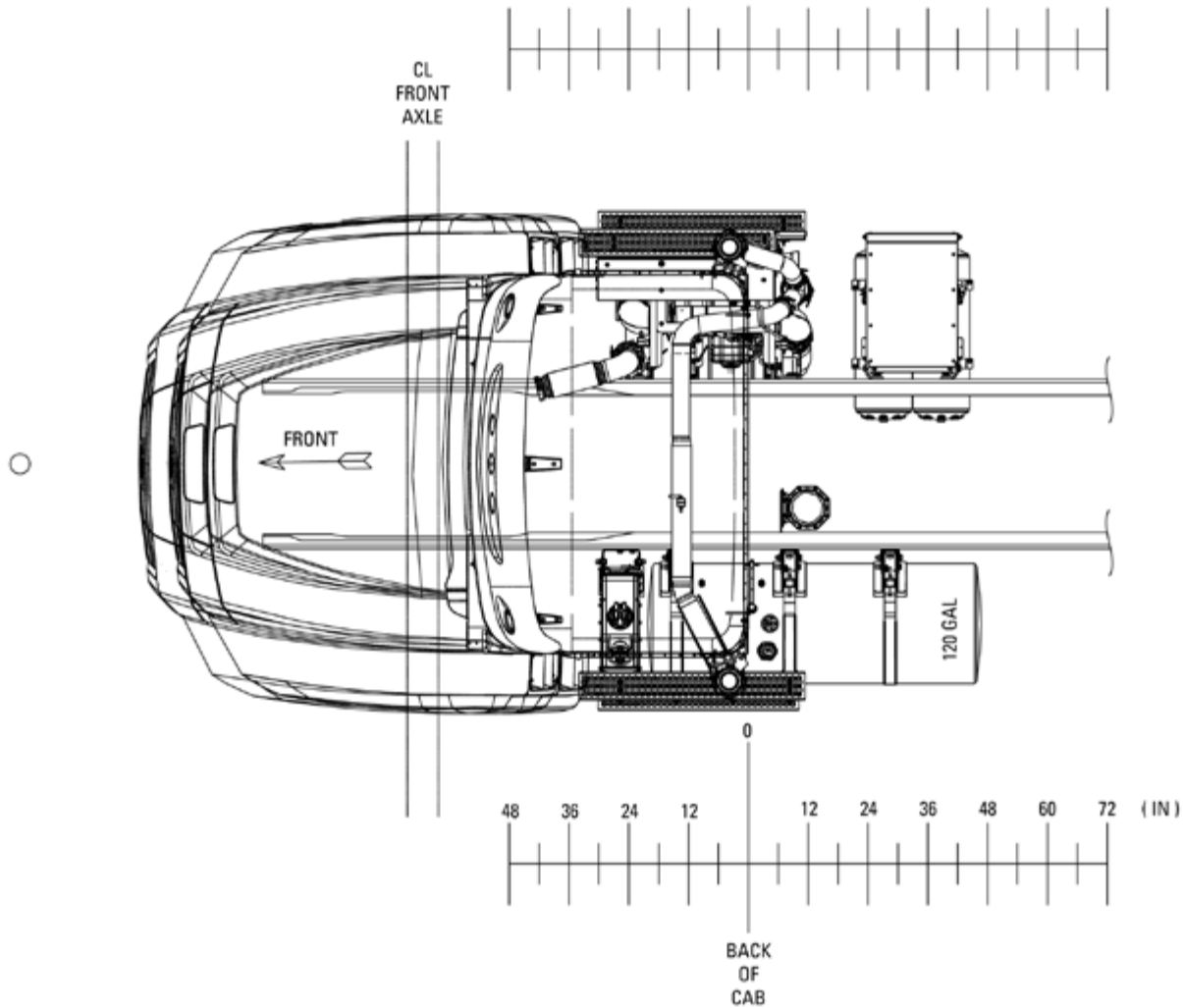

[↶ return to table of contents](#)

ALL MODEL SPECIFICATIONS

CHASSIS PACKAGING DIAGRAMS (SCR ONLY)

Model SBA 6x4 & 8x6, 70GAL 0015SWG-0015SWE, 9.5 U.S. Gal DEF 0015DYP, Switch Back Horizontal/Dual Vertical 0007DXM, Aux. Air Tank 0504078, Battery Box 0008VUK, Air Tanks 0504628

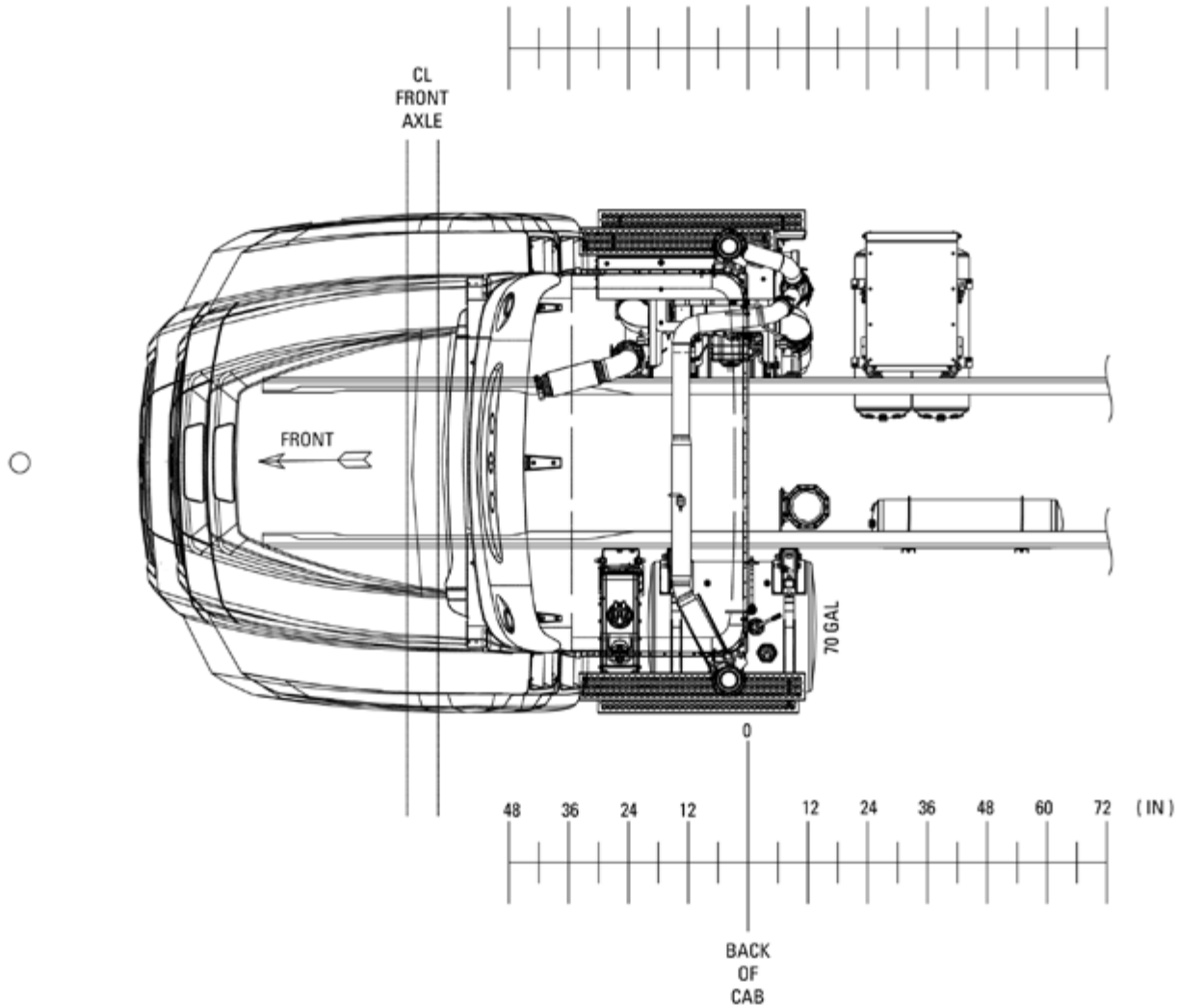

[↶ return to table of contents](#)

ALL MODEL SPECIFICATIONS

CHASSIS PACKAGING DIAGRAMS (SCR ONLY)

Model SBA 6x4 & 8x6, 80GAL 0015SGL-0015SJZ, 9.5 U.S. Gal DEF 0015DYP, Switch Back Horizontal/Dual Vertical 0007DXM, Aux. Air Tank 0504078, Battery Box 0008VUK, Air Tanks 0504628

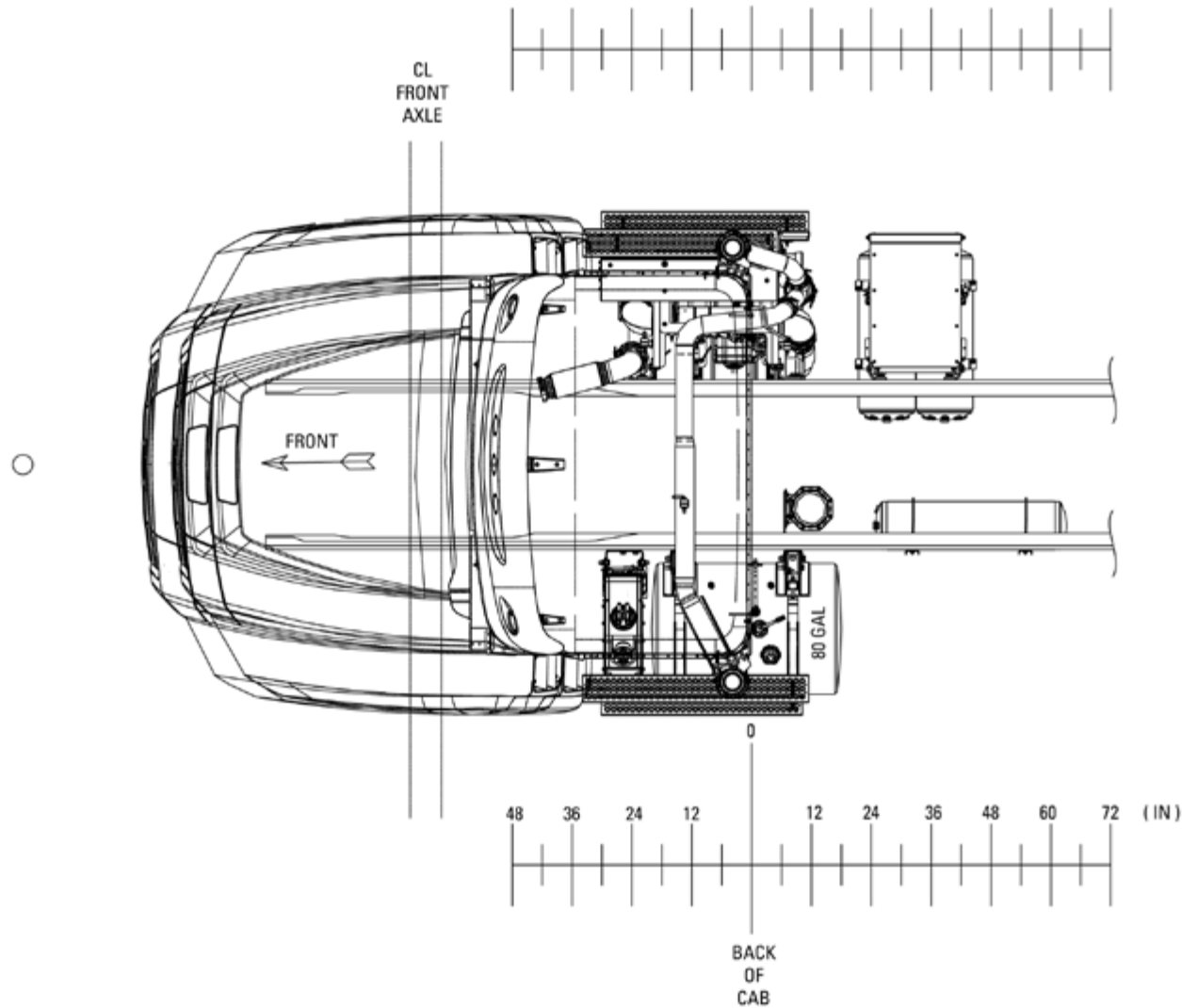

[↶ return to table of contents](#)

ALL MODEL SPECIFICATIONS

CHASSIS PACKAGING DIAGRAMS (SCR ONLY)

Model SBA 6x4 & 8x6, 100 GAL 0015SHC-0015SSK, 9.5 U.S. Gal DEF 0015DYP, Switch Back Horizontal/Dual Vertical 0007DXM, Aux. Air Tank 0504078, Battery Box 0008VUK, Air Tanks 0504628

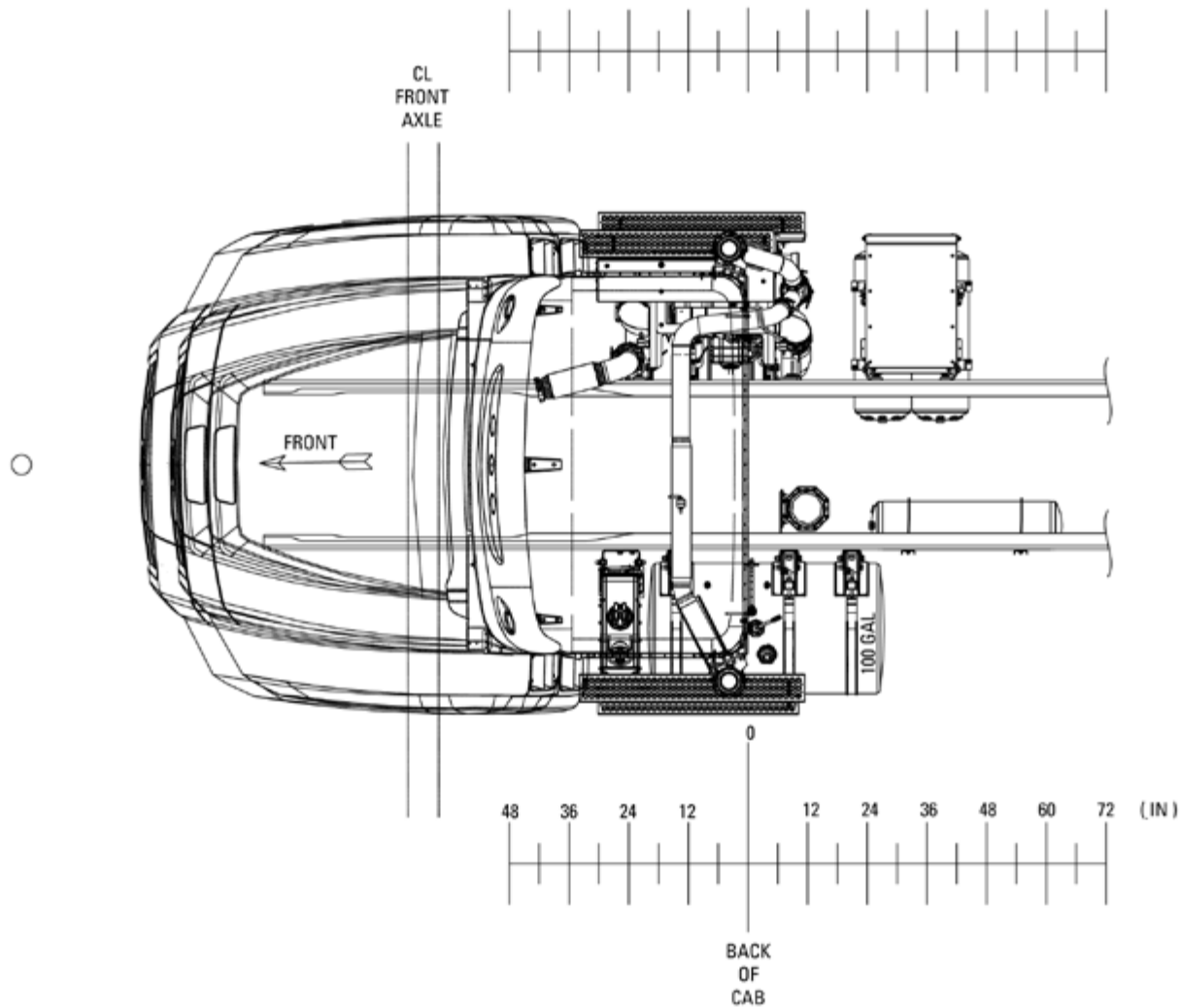

[↶ return to table of contents](#)

ALL MODEL SPECIFICATIONS

CHASSIS PACKAGING DIAGRAMS (SCR ONLY)

Model SBA 6x4 & 8x6, 120 GAL 0015SMZ-0015SSG, 9.5 U.S. Gal DEF 0015DYP, Switch Back Horizontal/Dual Vertical 0007DXM, Aux. Air Tank 0504078, Battery Box 0008VUK, Air Tanks 0504628

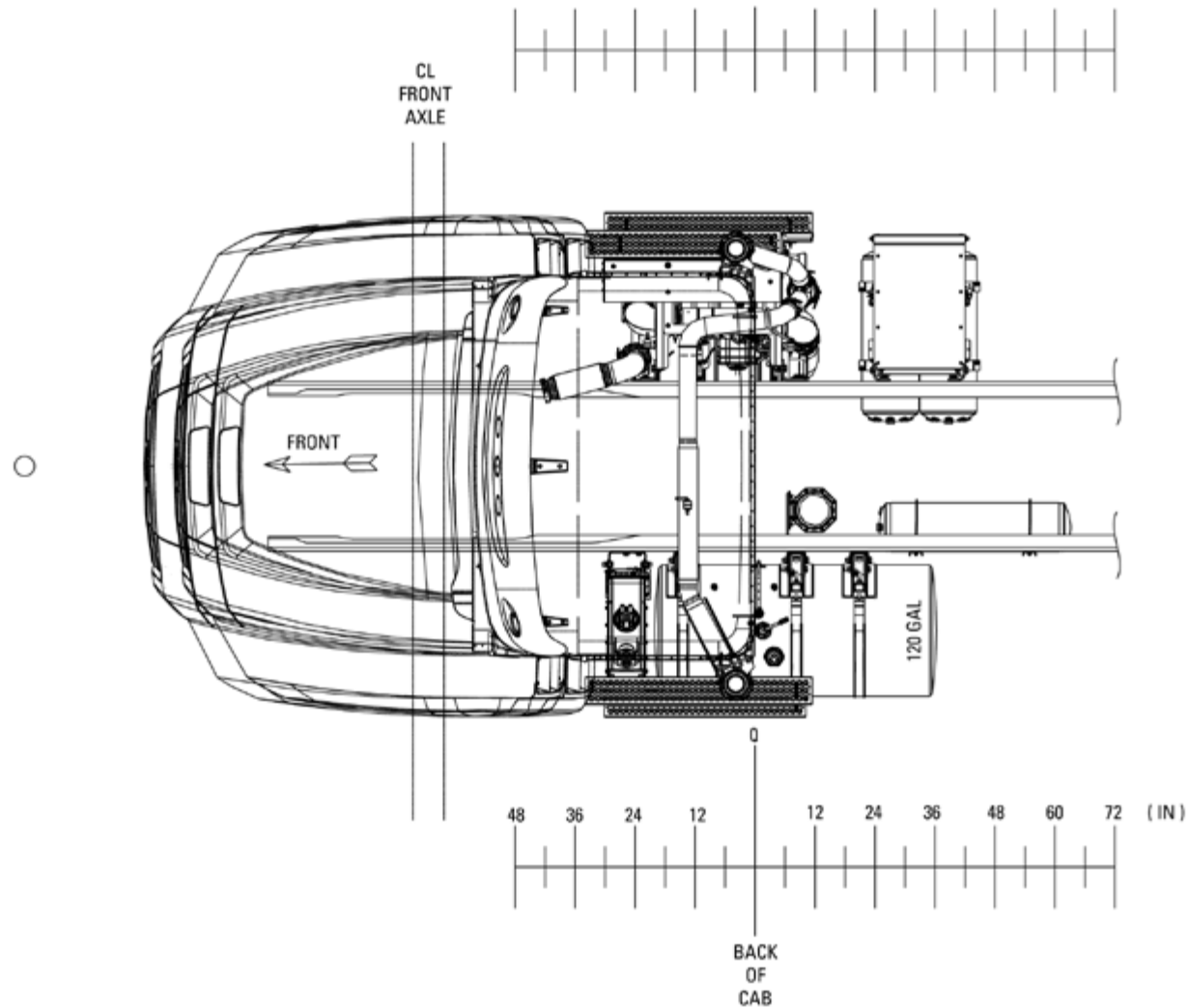

[↶ return to table of contents](#)

ALL MODEL SPECIFICATIONS

CHASSIS PACKAGING DIAGRAMS (SCR ONLY)

Model SBA 6x4 & 8x6, 80 GAL 0015SGL-0015SJZ-0015SSL, 9.5 U.S. Gal DEF 0015DYP, Switch Back Vertical/Single Vertical, Dual Cans 007BJX, Battery Box 0008TST, Air Tank 0504013

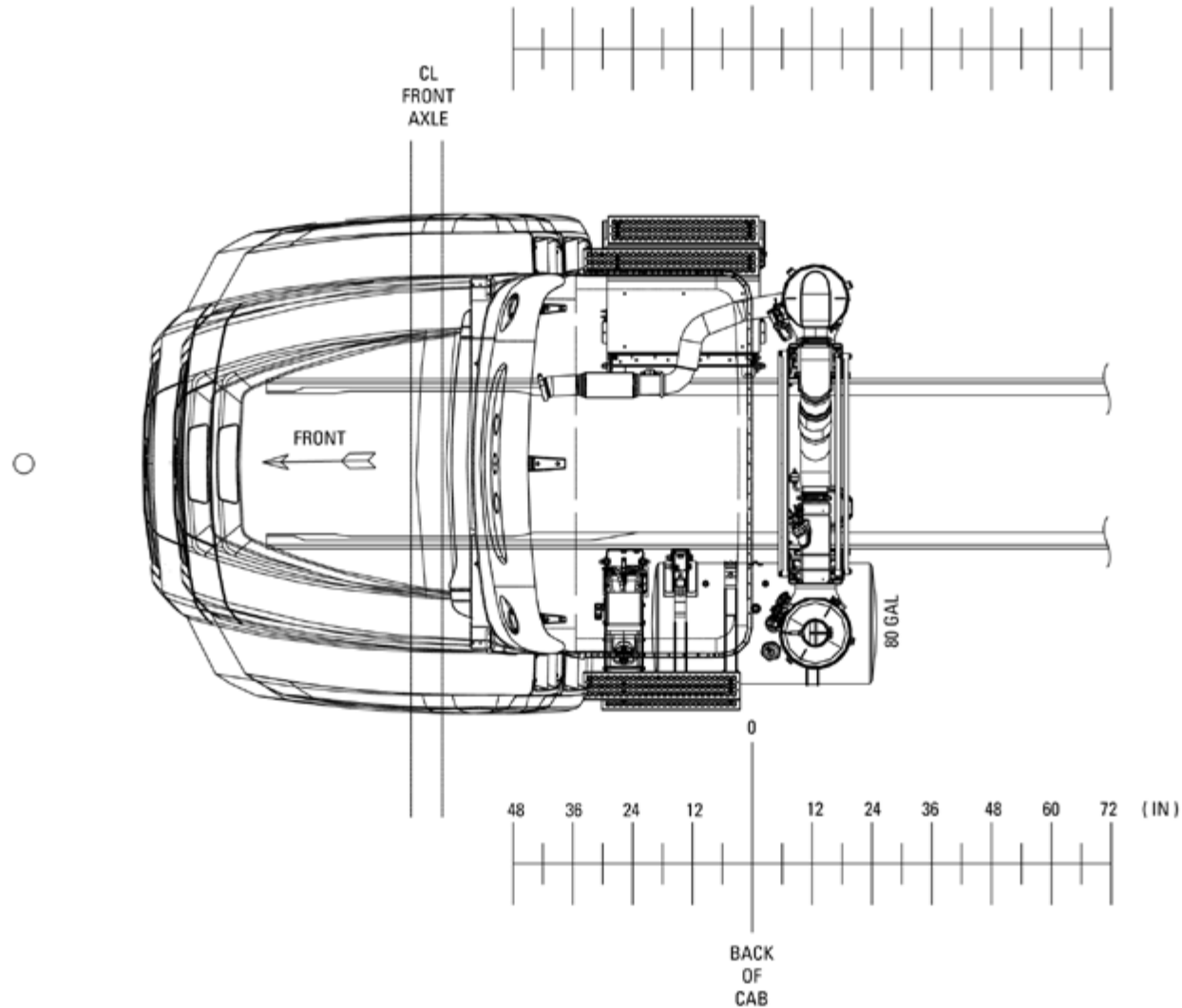

[↶ return to table of contents](#)

ALL MODEL SPECIFICATIONS

CHASSIS PACKAGING DIAGRAMS (SCR ONLY)

Model SBA 6x4 & 8x6, 100 GAL 0015SSK-0015SJK-0015SHC, 9.5 U.S. Gal DEF 0015DYP, Switch Back Vertical/Single Vertical, Dual Cans 007BJX, Battery Box 0008TST, Air Tank 0504013

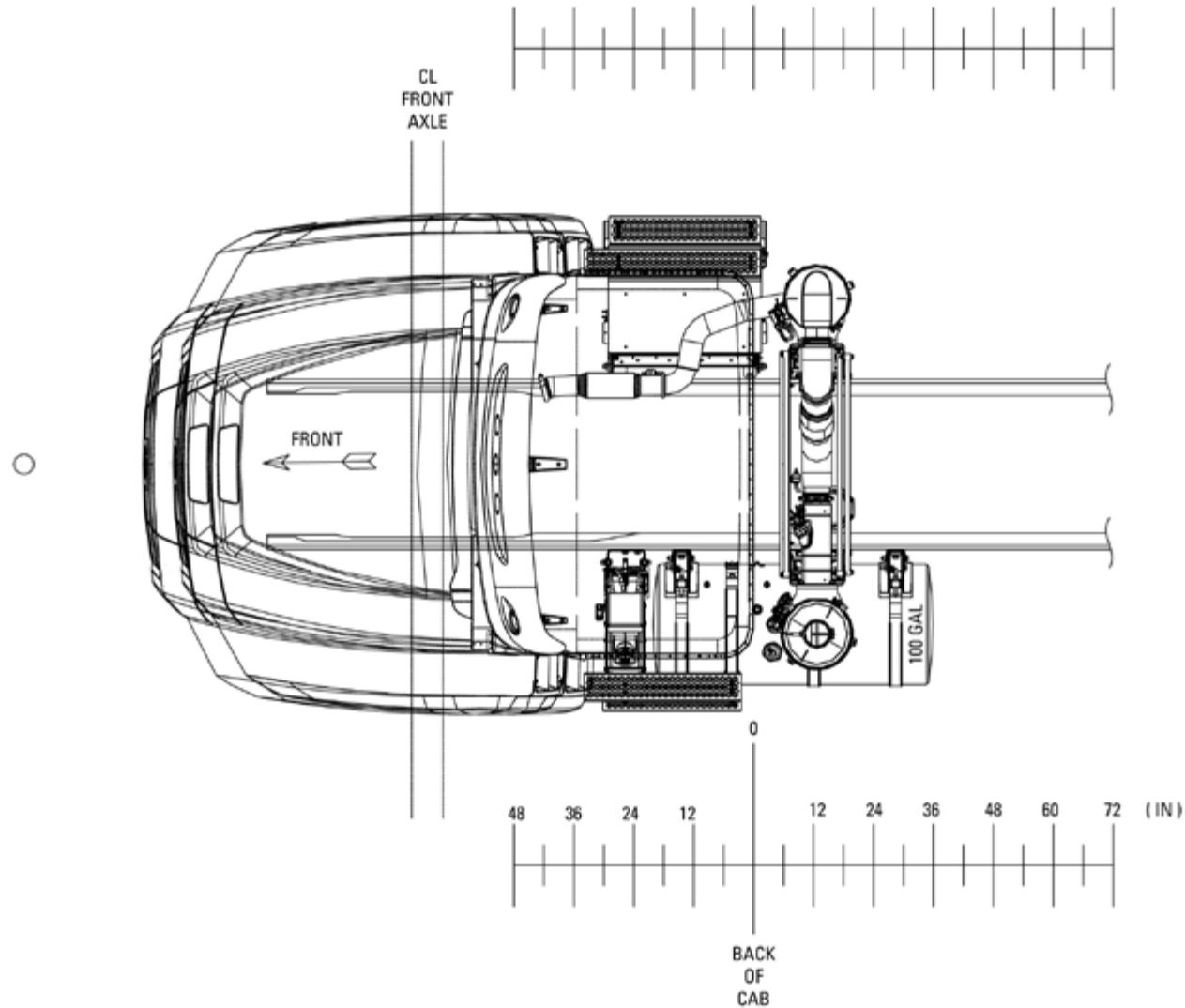

[↶ return to table of contents](#)

ALL MODEL SPECIFICATIONS

CHASSIS PACKAGING DIAGRAMS (SCR ONLY)

Model SBA 6x4 & 8x6, 120 GAL 0015SWK-0015SWJ-0015SSG-00015SMZ, 9.5 U.S. Gal DEF 0015DYP, Switch Back Vertical/Single Vertical, Dual Cans 007BJX, Battery Box 0008TST, Air Tank 0504013

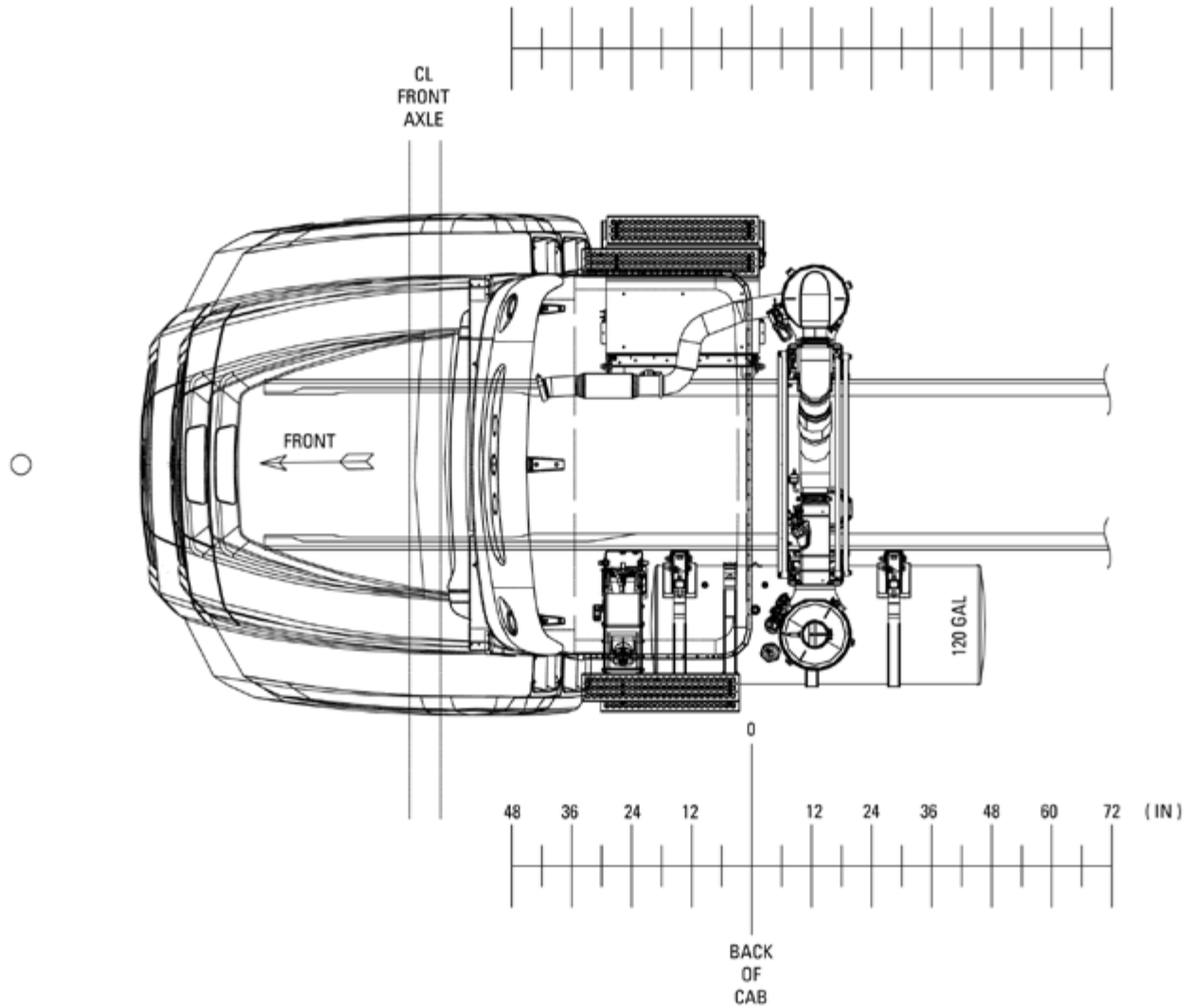

[↶ return to table of contents](#)

CT660 122BBC 6x4 & 8x6 CT15 SPECIFICATIONS

CHASSIS PACKAGING DIAGRAMS (EGR ONLY)

Model 6x4 & 8x6, CT15, 60GAL 0015DWP-0015DWR Vertical/Vertical 0007BDS and 0007SCS,
Aux. Air Tank 0504089, Battery Box and Air Tanks 0008TSW w/ 0504620, Hydraulic Tank 15WBV

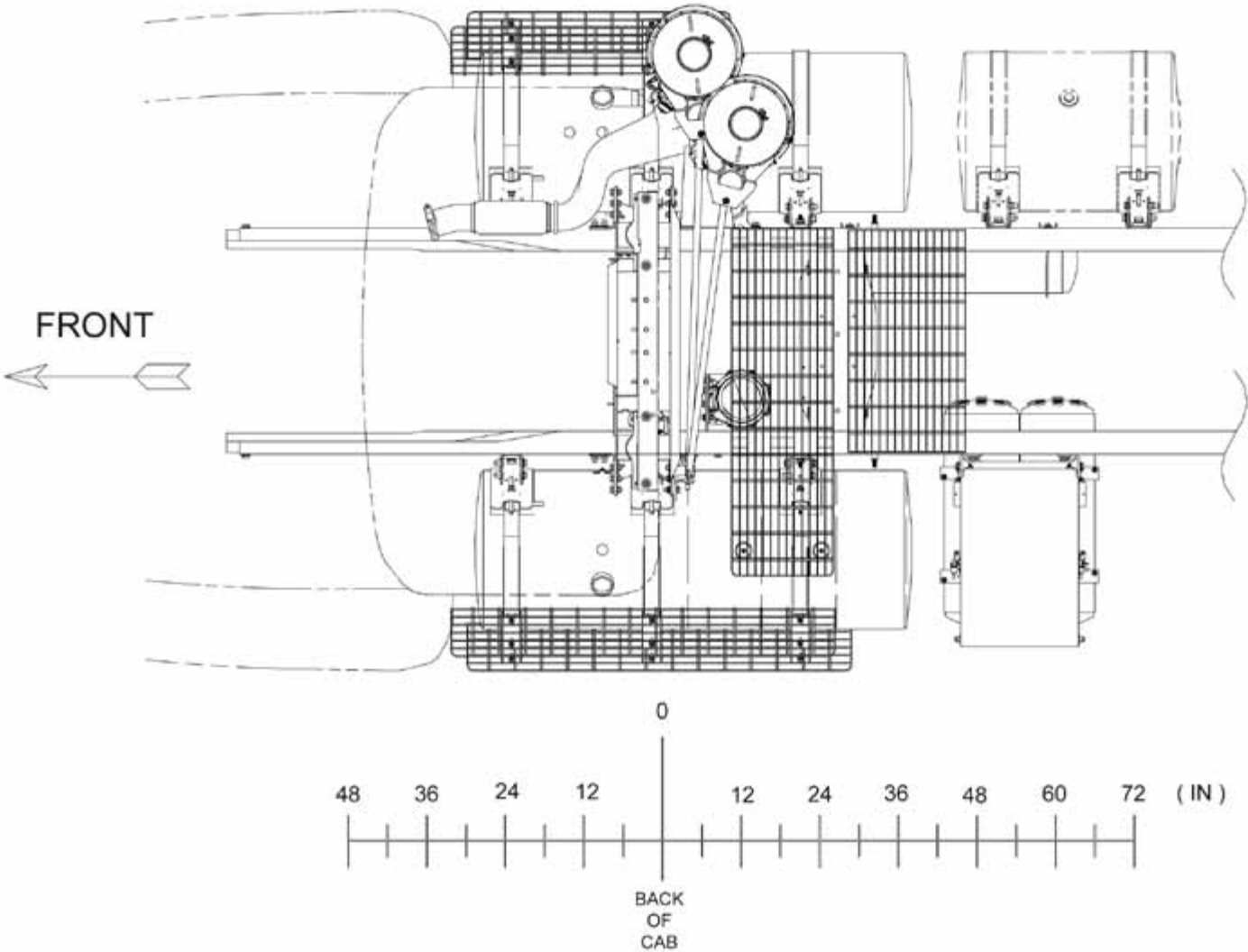

CT660 122BBC 6x4 & 8x6 CT15 SPECIFICATIONS

CHASSIS PACKAGING DIAGRAMS (EGR ONLY)

Model 6x4 & 8x6, CT15, 60GAL 0015DXA-0015DXB, 80GAL 0015DXC-0015DXD, Horizontal/Vertical 0007DHJ, Aux. Air Tank 0504114, Battery Box and Air Tanks 0008WKE w/ 0504013

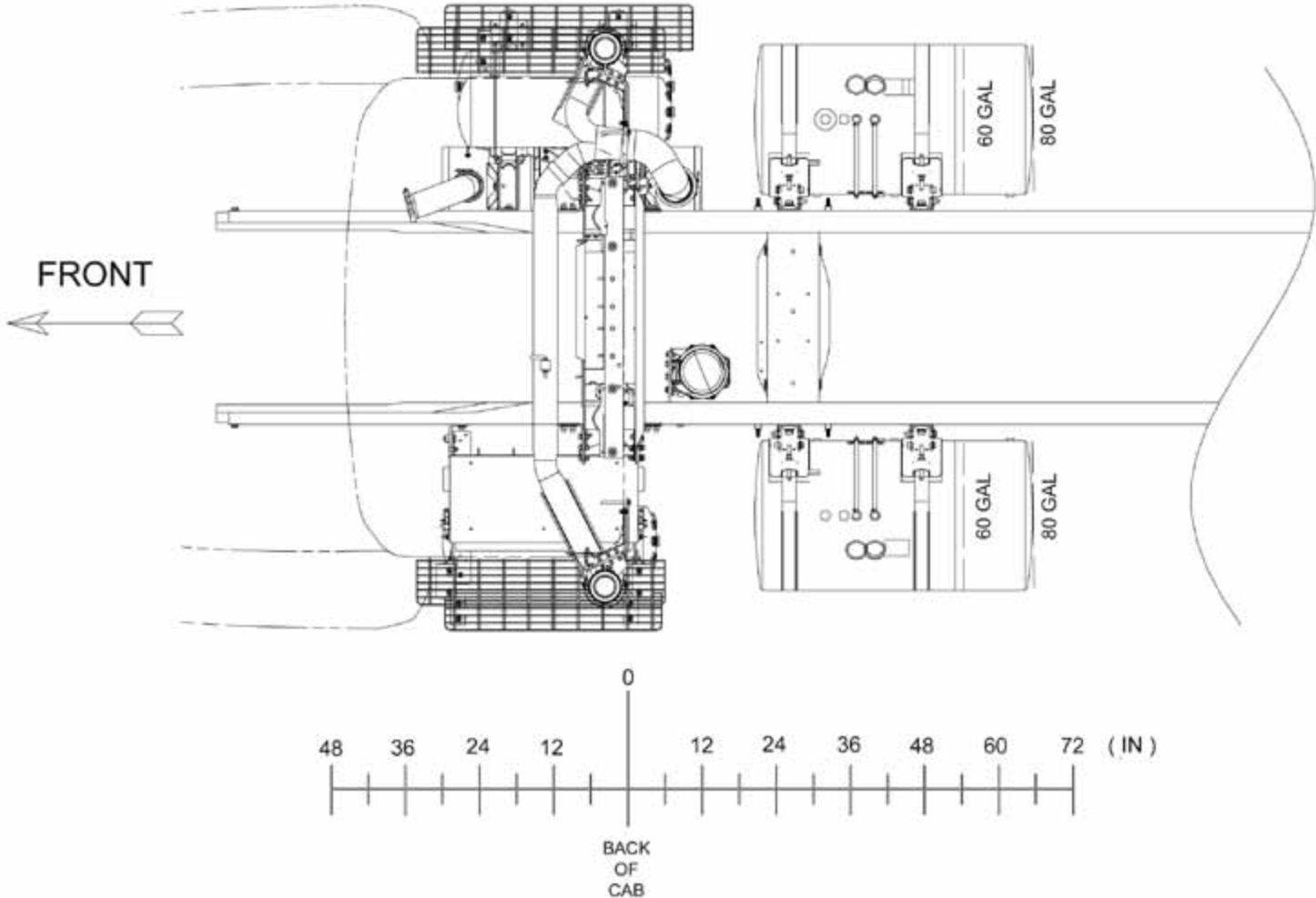

CT660 122BBC 6x4 & 8x6 CT15 SPECIFICATIONS

CHASSIS PACKAGING DIAGRAMS (EGR ONLY)

Model SBA 6x4 & 8x6, 60GAL 0015DXA-0015DXB, 80GAL 0015DXC-0015DXD, Horizontal/Vertical 0007DHJ
Aux. Air Tank 0504114, Battery Box 0008WKE, Air Tanks 0504013

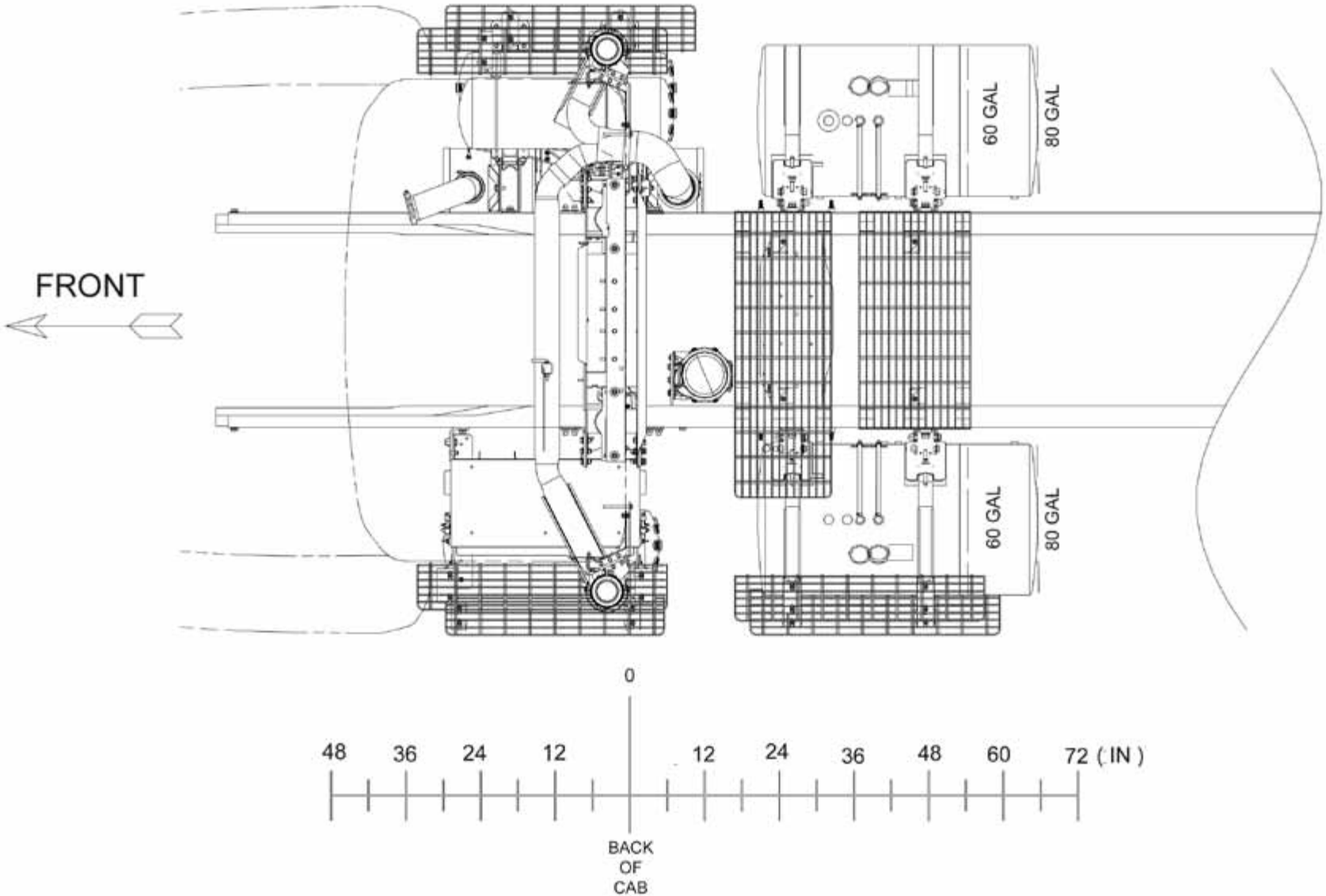

[↶ return to table of contents](#)

CT660 122BBC 6x4 & 8x6 CT15 SPECIFICATIONS

CHASSIS PACKAGING DIAGRAMS (EGR ONLY)

Model 6x4 & 8x6, CT15, 100GAL 0015DXE-0015DXG, 120GAL 0015DXH-0015DXJ, Horizontal/Vertical 0007DHJ,
Aux. Air Tank 0504114, Battery Box and Air Tanks 0008WKE w/ 0504013

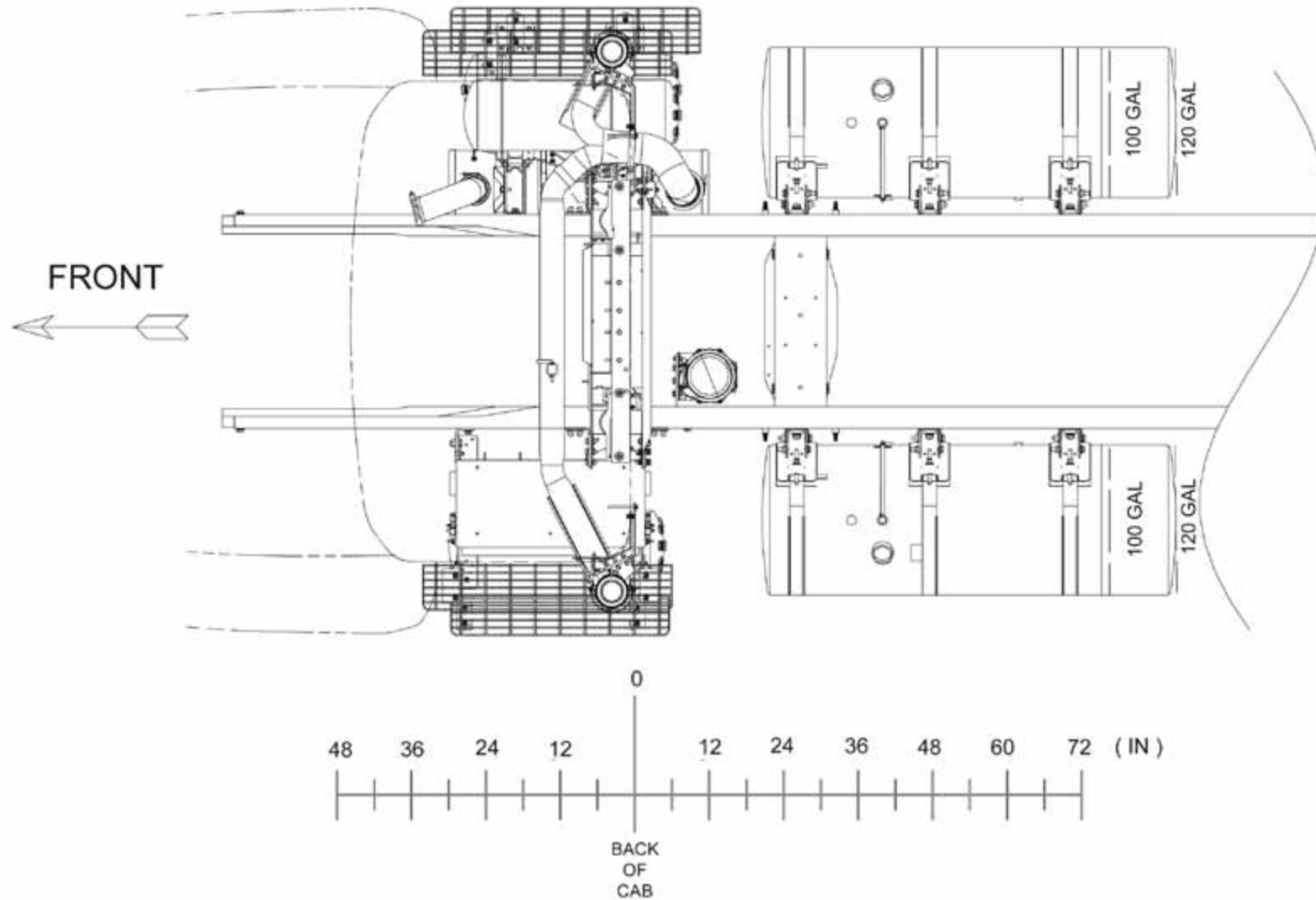

↪ [return to table of contents](#)

CT660 122BBC 6x4 & 8x6 CT15 SPECIFICATIONS

CHASSIS PACKAGING DIAGRAMS (EGR ONLY)

Model SBA 6x4 & 8x6, 100GAL 0015DXE-0015DXG, 120GAL 0015DXH-0015DXJ, Horizontal/Vertical 0007DHJ, Aux. Air Tank 0504114, Battery Box and Air Tanks 0008WKE w/ 0504013

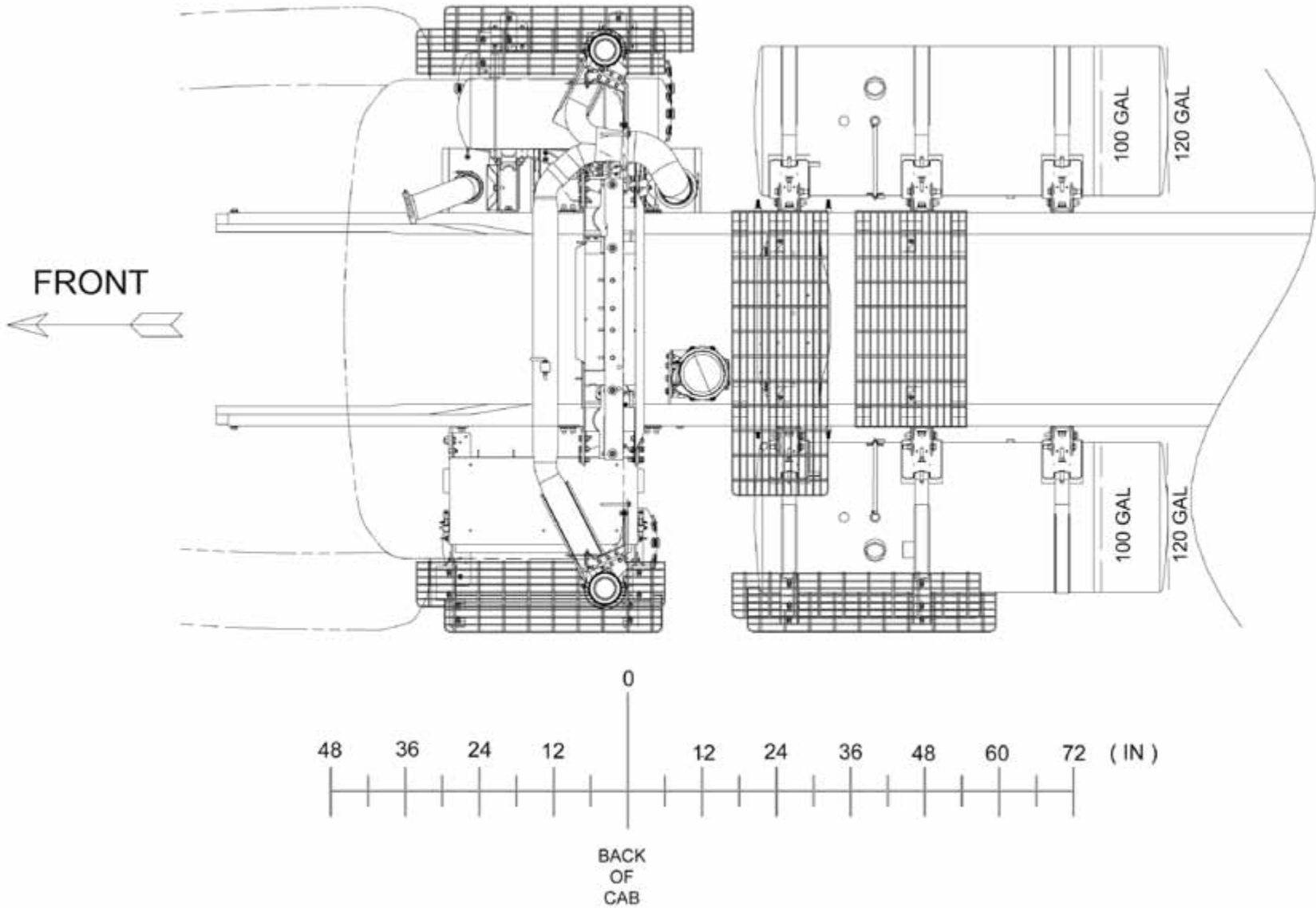

CT660 122BBC 6x4 & 8x6 CT15 SPECIFICATIONS

CHASSIS PACKAGING DIAGRAMS (EGR ONLY)

Model SBA 6x4 & 8x6, CT15, 120 GAL 0015DWP-0015DWR, Vertical/Vertical 0007BDS and 0007SCS, Aux. Air Tank 0504089, Battery Box and Air Tanks 0008TSW w/ 0504620, Hydraulic Tank 0015WBV

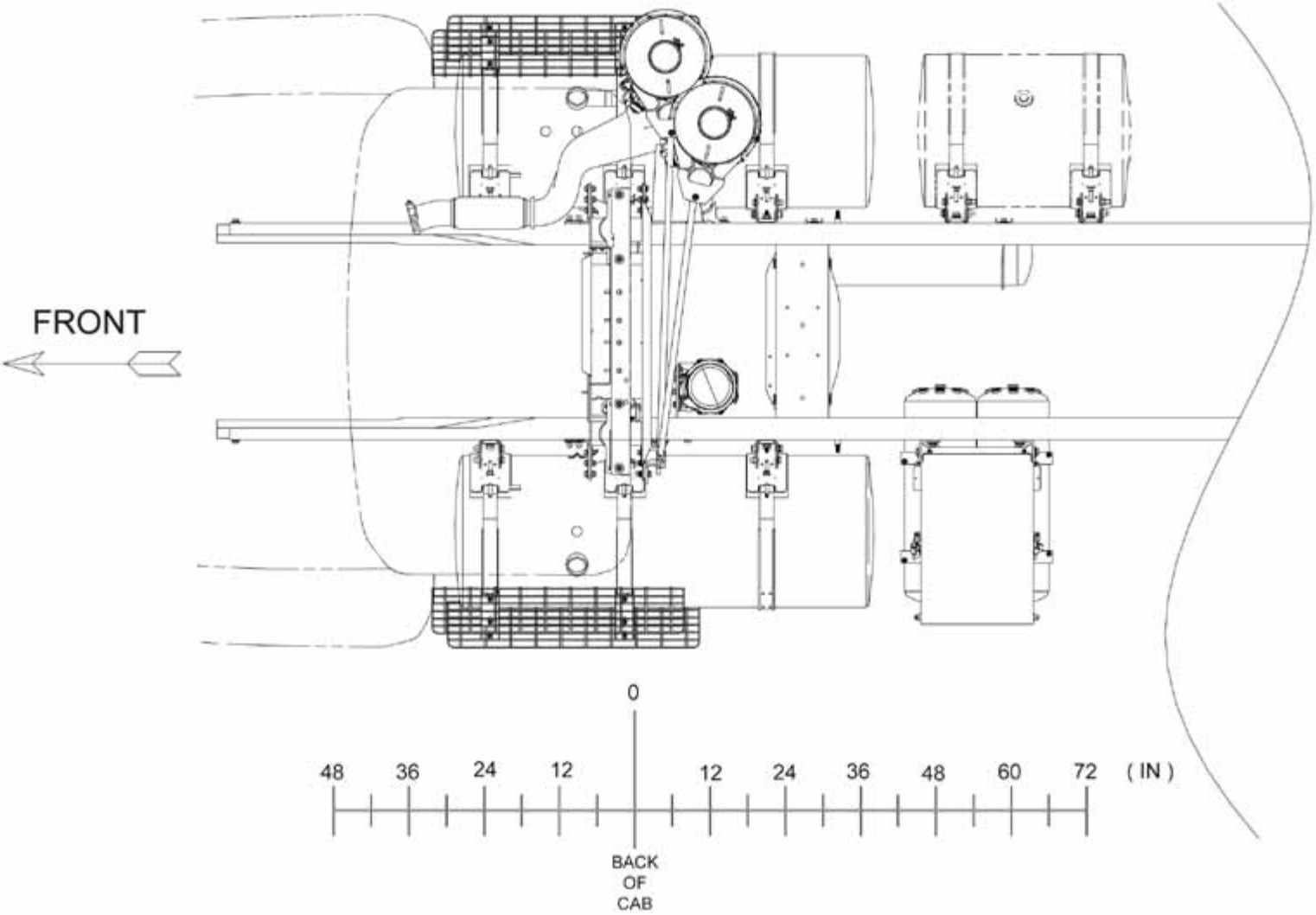

CT660 122BBC 6x4 & 8x6 CT15 SPECIFICATIONS

CHASSIS PACKAGING DIAGRAMS (EGR ONLY)

Model SBA 6x4 & 8x6, CT15, 120GAL 0015DWP-0015DWR, Vertical/Vertical 0007BDS and 0007SCS, Aux. Air Tank 0504089, Battery Box and Air Tanks 0008TSW w/ 0504620, Hydraulic Tank 0015WBV

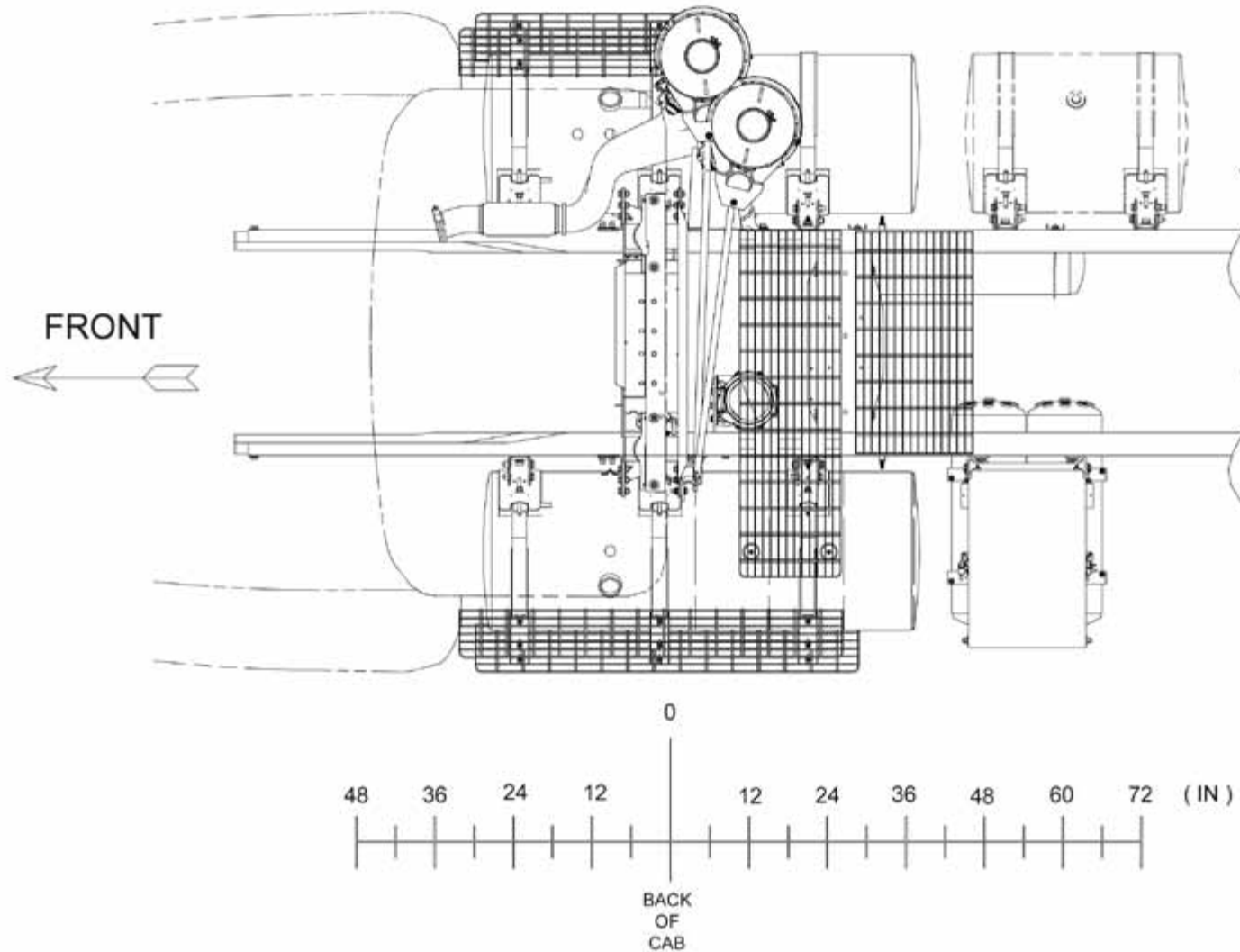

[↶ return to table of contents](#)

FRAMES

GENERAL FRAME RECOMMENDATIONS

Introduction

The frame is the structure that carries and supports the rated load under anticipated driving conditions and secures the major components of a vehicle in their relative positions. The frame assembly consists of two sidemembers and depending upon the length of the frame, five or more crossmembers.

General Frame Recommendations

It is very important that the frame be inspected periodically for cracks, buckling, crossmember loosening or other damage that may cause eventual failure of the frame. Additional inspections should be made whenever the chassis has been overloaded or involved in an accident. An alignment check IS NOT SUFFICIENT since local cracks, crossmember loosening or sidemember buckling will not necessarily cause misalignment.

On reinforced sidemember sections, when cracks exist in either of the sidemember sections, the members must be separated for repair. After separation follow the procedures for non-reinforced sections. The two sidemember sections MUST NOT be welded together. After the weld repairs, the sections should be reinforced with the appropriate section and re-assembled with mounting bolts tightened to SAE Grade 8 torque levels.

Drilling or Notching

Sidemembers should not be drilled or notched without approval from Caterpillar Engineering. The maximum allowable sidemember hole size in the unrestricted zones. See model specific books for illustrations.

Welding or Flame Cutting

Welding or flame cutting of the frame components is unacceptable because of the associated loss of fatigue strength. This restriction applies not only to the heat-treated components, but also the high strength low alloy (HSLA) and low carbon steel components.

Exceptions to this are cases with Caterpillar Engineering approval or for repair operations as described in this service manual section.

To avoid serious personal injury, death or possible engine damage, when welding or using an acetylene torch always wear welding goggles and gloves. Insure that acetylene and oxygen tanks are separated by a metal shield and are chained to a cart. Do not weld or heat areas near fuel tanks or fuel lines. Utilize proper shielding around hydraulic lines.

FRAMES

GENERAL FRAME RECOMMENDATIONS

Reinforcement to Increase Capacity

Reinforcement of the chassis frame to support either additional loading or concentrated loading does not increase vehicle load carrying capacity unless it has been fully verified that all other vehicle components, such as the brake system, steering system, suspension system, etc. can properly and safely support the increased loading.

Increase in Local Stress

In any modification of the chassis frame, the addition of holes, reinforcements, welds, clamps, splices, etc., may cause an increase in the local stress in the frame at the point of the modification, **therefore causing a stress concentration in the frame sidemember(s)**. These local stress concentrations can significantly affect the life of the chassis frame. The specific effect which the stress concentrator will have on the life of the chassis frame is influenced by the location of the stress concentration, the frequency and severity of the loading, and the magnitude of stress concentration. Deviation from the repair procedures in this section may void manufacturer's warranty.

FRAMES

IDENTIFICATION OF FRAME RAIL MATERIAL

Cat® chassis are manufactured with frame rails of different alloy steels and some are heat-treated. Each material must be handled in a specific manner to assure maximum service life; therefore, the frame material must be determined before attempting repair or modification. Cat chassis are presently manufactured with frame rails of:

- » High strength low alloy (HSLA) steel (50,000, 60,000 and 80,000 PSI yield strength)
- » Heat treated steel (110,000 and 120,000 psi yield strength)

Each type has different repair procedures. The frame rail material can be determined by inspecting the frame and consulting the dealer vehicle lineset ticket and the sales data book. Heat-treated rails are marked on the inside of the section with a decal which cautions against welding, flame cutting or the addition of holes in critical zones. These practices are restricted for all frame rails, however, heat-treated rails are much more sensitive to these alterations.

FRAMES

FRAME DAMAGE

The major sources of frame damage are accidents, overloading the vehicle, and local overstressing due to a variety of causes. In accident cases, the reasons for the damage are readily apparent. Such damage may often be repaired by:

- » Straightening and reinforcing the frame.
- » Repairing the damaged area and reinforcing the frame sidemember.
- » Replacing the frame sidemembers and crossmembers.

Damage to the chassis frame, such as a crack in the frame sidemember or crossmember, which is not associated with impact damage, may be an indication of overloading the vehicle. Damage to the chassis frame may also be an indication of the creation of locally high stresses due to operating conditions or equipment mounting practices. Examples of overloading are:

- 1) Uneven load distribution.
- 2) Improper fifth wheel settings.
- 3) Using the vehicle in operating conditions or with equipment it was not designed for.

Examples of creation of locally high stresses are:

- 1) Mounting bodies or equipment in a manner that causes stress concentrations and/or abrasive wear in either the flange or web portion of the sidemember.
- 2) Improper modification or repair of frame components.
- 3) Equipment which is susceptible to resonant vibration due to excess flexibility of its mounting.

Frame damage may also be caused by corrosion resulting from the contact between dissimilar metals.

Damage to the chassis frame, which is not associated with impact damage, should not be repaired until the cause of the damage has been determined and corrective actions taken to prevent re-occurrence of the non-impact damage.

FRAMES

WELDING AND REINFORCEMENT

The guidelines below deal with the general procedures for weld repair and reinforcement. Because of the many variables associated with these repairs, it is recommended that your field service representative be consulted prior to undertaking the repair. This will also help to determine whether a specific set of recommendations has already been developed for the case in question.

The essential elements of repairing the sidemembers are the restoring of BOTH the shape and local strength so that the load capacity is at least as good as before the damage occurred. The sidemembers may look like new, but may have local strength reduction due to small cracks or material strength reduction. Even if the frame has acceptable alignment and there is no gross deformation, local deformations may reduce the strength in the area to be weld repaired. Examples of this are local bulges in the web (vertical portion) of the section and buckling of the flanges. These local deformations must be repaired by straightening before proceeding with the weld repair.

Welding Precautions

When welding on any vehicle, care must be taken to prevent damage to the electronic components. Vehicles with ELECTRONIC ENGINE CONTROL SYSTEMS require additional precautions.

CAUTION: On any vehicle, disconnect both the positive and negative battery cables from the battery before welding on the vehicle. Attach the welder ground cable as close as possible to the part being welded.

To avoid serious personal injury, death or possible engine damage, when welding or using an acetylene torch always wear welding goggles and gloves. Insure that acetylene and oxygen tanks are separated by a metal shield and are chained to a cart. Do not weld or heat areas near fuel tanks or fuel lines. Utilize proper shielding around hydraulic lines.

With an electronic engine controller (such as Celect), do not connect the ground cable to the control module(s) or the cooling plate. To protect the control module(s), it is mandatory to remove all connectors going to the control modules.

The following is a general guideline for the steel frames: Welding of the HSLA (50,000, 60,000 and 80,000 PSI yield strength) steel side member and the heat-treated (110,000 and 120,000 PSI yield strength) steel sidemember involves a significant reduction in the strength of the frame in the heat affected zones of the weldment. This means that the frame in the welded region is no longer capable of carrying the same load or stress as the original section. To restore the strength of the frame rails after welding, the welded area must be reinforced using reinforcements as indicated in "Repair and Reinforcement Recommended Procedures". Welding must be done properly to make an effective repair. Therefore, only those who are properly trained and qualified should perform the welding repairs in this section.

FRAMES

WELDING AND REINFORCEMENT

Reinforcement

Reinforcements (Figure 1.1) to increase load capacity are generally “full length”. The actual length of the reinforcement varies with the model. Shorter, (approximately 7’) rear suspension tandem liner reinforcements are available for some tractor models. Inverted “L” and “C” channel reinforcements are available for most models. For models which do not have reinforcements necessary to contact Sales Engineering to obtain reinforcement recommendations.



| 1 | 2 | 3 |
|---|--|---|
|  |  |  |
| STANDARD SIDEMEMBER SECTION | HEAVY DUTY SIDEMEMBER SECTION | C-REINFORCEMENT SIDEMEMBER SECTION |

Figure 1.1 Frame Rails and Reinforcements (Typical)

These reinforcements are generally installed on the outside of the sidemember, although certain models require “C” channel reinforcements installed to the inside of the sidemember. Contact your Cat® Truck dealer regarding the required type of reinforcement. Depending on model application, there will be other parts affected, such as spring brackets for example, which are bolted to the flange as well as the web of the sidemember. To maintain proper alignment of the springs, these brackets may require replacement with new brackets designed to accept the reinforcements. These brackets are available through your Cat Truck Dealer parts department. **NOTE:** When an inside reinforcement is added, the lengths of the crossmembers will be affected.

Reinforcement Attachment

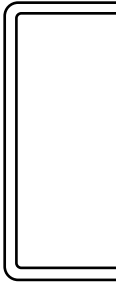
The reinforcements must never be welded to the original chassis sidemembers. High strength SAE Grade 8 bolts are to be used to fasten the reinforcement to the sidemember. Existing bolt holes in the sidemembers should be used whenever possible.

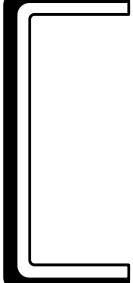
NOTE: The reinforcements should be bolted to the chassis frame using high strength SAE Grade 8 bolts not less than 0.5 inch (13 mm) in diameter (refer to “Bolt and Torque Information”).

FRAMES

CORROSION

If aluminum and steel are allowed to come into direct contact with each other, a galvanic cell can be formed. In order for the cell to form, the dissimilar metals must be in direct contact and an electrolyte, such as moisture, must be present. Aluminum is anodic with respect to steel and will corrode when in the presence of steel. Corrosion of aluminum frame crossmembers will reduce the load carrying capacity of the frame member and may eventually lead to the failure of the frame.

To prevent the formation of a galvanic cell, isolation techniques such as non-conductive or barrier type spacers or sealers must be used so that the steel and aluminum are not in direct contact.

It is recommended that a sealer, such as Tectyl 400C or equivalent, be painted onto the surface of both the aluminum and steel, as well as on the washers under the head of the bolts and nuts.

FRAMES

FRAME ALIGNMENT

The frame must be properly aligned as this affects body, axle and suspension mounting. If the vehicle has been involved in an accident or has been overloaded, it is recommended that the frame be checked for proper alignment.

Pre-Alignment Inspection

Before checking alignment, park vehicle on level ground and set parking brake. Inspect frame assembly for loose parts, welds, cracks and bends. Be sure to make all necessary repairs before attempting to check frame alignment.

Method of Checking Frame Alignment

A satisfactory method of checking the frame and axle alignment, particularly when a body and cab is on a chassis, is to:

- 1) Place a plumb bob against the point of measurement. All measurements must be taken with the plumb bob positioned against bare metal.
- 2) Tack or tape pieces of paper to the floor directly under each point of measurement on the chassis as indicated by the letter "K" in Figure 1.2.

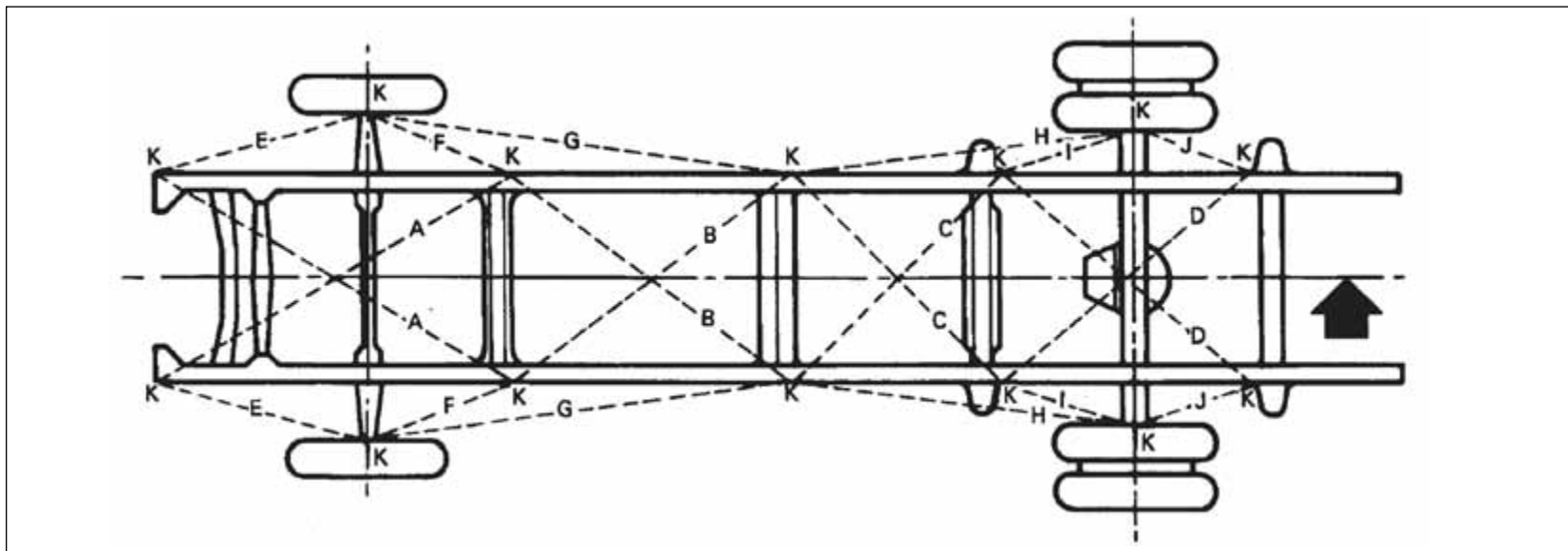

Figure 1.2 Centerline of Chassis

FRAMES

FRAME ALIGNMENT

Method of Checking

After each measurement point has been carefully marked on the floor, proceed as follows:

- 1) Locate centerline of chassis by measuring front and rear end widths, using marks on floor. If frame widths are within specification, draw centerline on floor, the full length of the chassis and continue with step 2. If frame widths are out of specification, lay out centerline as follows: Centerline can be drawn through the intersection of any one pair of equal diagonals (A-A, B-B, C-C, D-D) and center point of one end of frame or through points of intersection of any two pairs of equal diagonals.
- 2) Measure distance from centerline to opposite points marked over entire length of frame. Measurements should not vary more than 0.12 inch (3.0 mm) at any point.
- 3) Measuring diagonals (A-A, B-B, C-C, D-D) will indicate point where misalignment occurs. If diagonals in each pair are within 0.12 inch (3.0 mm), that part of the frame included between points of measurement may be considered in satisfactory alignment. These diagonals should intersect within 0.12 inch (3.0 mm) of the centerline. If the diagonals are not within specification, try loosening and re-tightening all cross-members. Then re-check alignment. Refer to the "Bolt Torque Chart (Phosphate and Oil Coated)". If frame is still out of alignment, the vehicle must be taken to a suitable frame alignment establishment to confirm frame misalignment. If misalignment is confirmed, suitable measures must be taken to repair the damage.

Side Elevation Dimensions

Dimensions for side elevation of the frame should be checked at the points indicated and should not vary more than 0.12 inch (3.0 mm) from side to side. (They will differ fore and aft due to typical frame rake.)

Axle Alignment With Frame

After determining that the frame is properly aligned, the axle alignment with the frame should be checked by comparing diagonals. If necessary, adjust axle-to-frame alignment.

Frame Straightening

NOTE: Frame straightening should only be performed by a qualified frame alignment facility. Under no circumstance should frame alignment be performed by inexperienced or unqualified service personnel. **Do not use heat to straighten.**

Use of heat is not recommended when straightening heat-treated frame sidemembers. Heat will weaken these frame members, consequently, all straightening should be done at room temperature. Add reinforcement per section if heat straightening is done. Frame members which are bent or buckled sufficiently to show cracks or weakness after straightening should be replaced or reinforced. **Heat-treated frame members must not be intermixed with non-heat-treated members.**

If one sidemember is to be replaced, the new member must match the former frame member in both cross-section and material strength.

FRAMES

REPAIR AND REINFORCEMENT RECOMMENDED PROCEDURES

In some cases of frame damage, the sidemembers must be replaced rather than repaired. Examples of this are:

- 1) When sidemember cracks caused complete separation or a visible deformation of the section.
- 2) When the sidemembers are extensively deformed. Consult with your field service representative and frame repair specialists if in doubt.

Preparation of Frame for Repair

Bevel Crack to Weld

To assure complete weld penetration, bevel the crack from one side when welding from one side. Bevel the crack from both sides when welding from both sides. The existing crack in the sidemember must be entirely removed (Figure 1.3). Widen the crack its full length to 1/8 inch (3 mm). If required, a rubber backed disc grinder or high speed steel burr may be used.

Clean Surface to Weld

Surfaces to be welded and surfaces adjacent to the weld must be free of loose scale, slag, rust, grease, moisture, paint or other material that could contribute to poor quality welds.

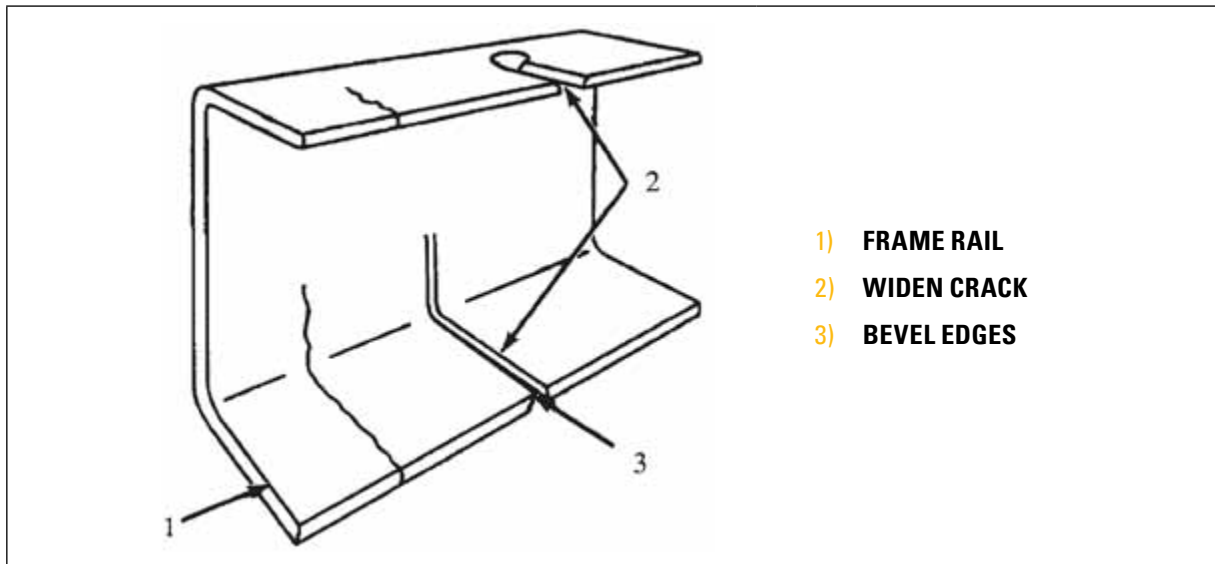

Figure 1.3 Preparing for Weld Repair

FRAMES

REPAIR AND REINFORCEMENT RECOMMENDED PROCEDURES

Welding

Electric arc-welding is recommended for repair of steel frames. The shielded arc method should be used because the heat generated during welding is localized and burning of material is minimized using this method. Additional advantages are that the finished weld can be ground flush and drilled as necessary. Shielded metal arc welding (SMAW); gas metal arc welding (GMAW), also known as metal inert gas (MIG) welding; gas tungsten arc welding (GTAW), also known as tungsten inert gas (TIG) welding; or flux cored arc welding (FCAW) are recommended methods for repair of steel frame members.

To avoid serious personal injury, death or possible engine damage, when welding or using an acetylene torch always wear welding goggles and gloves. Insure that acetylene and oxygen tanks are separated by a metal shield and are chained to a cart. Do not weld or heat areas near fuel tanks or fuel lines. Utilize proper shielding around hydraulic lines.

General Recommendations

IMPORTANT: To properly perform the repair procedure, the following rules must be observed:

All Steel Sidemembers

- 1) Welding should not be performed when surfaces are wet or exposed to rain, snow, high wind or when repair personnel are exposed to inclement conditions. Frames exposed to inclement weather must be thoroughly cleaned and dried before the repair is made.
- 2) Surface areas and edges to be joined must be clean and free of oil, grease, loose scale, rust, moisture, paint or other material that could contribute to poor quality welds.
- 3) Always avoid craters, notching and undercutting.
- 4) Peen new welds prior to grinding to relieve stresses caused by shrinkage.
- 5) Grind all welds flush with the surrounding surfaces. Use a coarse grinder followed by smooth grind at 90° to the crack direction to remove all of the coarse grind marks.
- 6) Inspect the weld repaired area carefully after grinding. Grind out any remaining cracks, notches or undercuts and repeat the finishing and inspections.
- 7) For welding cracks to the edge of the sidemember flange, locate a run-off block at the edge as in to obtain a continuous weld without undercuts. After welding, the run-off block should be cut off and the weld should be ground and inspected as in steps 5 and 6 above.

FRAMES

REPAIR AND REINFORCEMENT RECOMMENDED PROCEDURES

- 8) Weld to the edges of the holes: The weld should continue into the hole to form a plug weld with a copper chill block on the opposite side to help form the plug. The weld should then be finished as in steps 5 and 6 above and redrilled. Chamfer the hole edges. If the hole was open and unused, install a Grade 8 bolt to help attach the weld repair reinforcement.

Invisible ultraviolet and infrared rays emitted in welding can injure unprotected eyes and skin. Protection such as welder's helmet with dark colored filter lenses of the proper density must be used. GTAW or TIG welding will produce intense radiation, therefore, filter plate lenses of the deepest shade providing adequate visibility are recommended. It is strongly recommended that persons working in the weld area wear flash safety goggles. Also wear protective clothing.

- 9) Electrodes: Only low hydrogen electrodes should be used. These should be purchased in hermetically sealed containers or dried for two hours at a temperature between 450° F (232° C) and 500° F (260° C).

After drying, the electrodes should be stored in an oven at a temperature of at least 250° F (121° C). If exposed to the atmosphere for more than four (4) hours, the electrodes should be dried before use. Any moisture introduced into the weld could develop porosity or embrittlement, leading to further cracking. Welding procedures will vary among different frame materials. Outlined below are recommendations for welding of the various types of frames.

- 1) Preheat the frame member along the prepared weld joint to 500 to 600° F (260 to 316° C). Insure the area is clean and any moisture present is eliminated.
- 2) Permit heated area to cool to 200° F (93° C) or below before welding is started. The weld repair area must be clean before welding.
- 3) Either alternating current or direct current reversed polarity, combined with a short arc and beading or narrow weave technique, may be used. Direct current reversed polarity is recommended.
- 4) Slag should be removed after each pass and an interpass temperature of 200° F (93° C) should be maintained.
- 5) Grind smooth and flush with surrounding sidemember material. Grind the weld in a direction that is 90° to crack direction (Figure .D).
- 6) Add reinforcement.

FRAMES

REPAIR AND REINFORCEMENT RECOMMENDED PROCEDURES

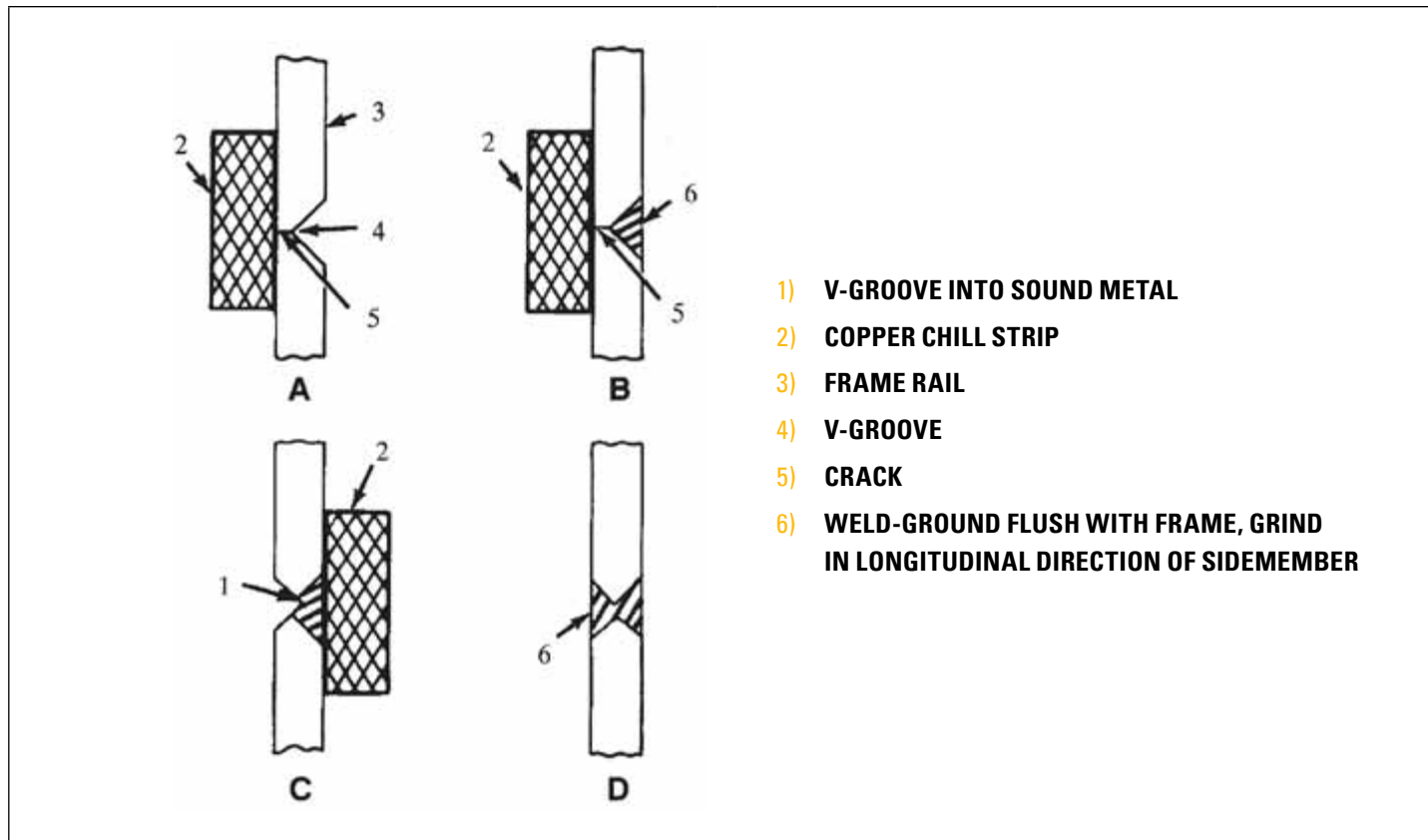

Figure 1.4 Use of Chill Strip

High Strength Low Alloy Steel Frames (50,000, 60,000 and 80,000 PSI Yield Strength)

Any of the electric arc methods previously described may be used. The choice of a suitable electrode or wire depends somewhat upon the equipment available for welding and the method selected.

The SMAW and the GMAW methods are preferred for welding the HSLA frames. The use of low hydrogen electrodes is recommended. Refer to Table 1.1 for selection of recommended electrodes and wires, or refer to A.W.S. A.5 standard available from www.aws.org for equivalent strength electrodes, wires or rods and power leads to be used in the welding methods. The double Vnotch weld preparation using the weld procedure shown in Figure is the preferred welding method.

FRAMES

REPAIR AND REINFORCEMENT RECOMMENDED PROCEDURES

| MATERIAL STRENGTH PSI | RECOMMENDED ELECTRODE AND WIRE | |
|-----------------------|--------------------------------|---------|
| | SMAW | GMAW |
| 50,000 | E7018 | E70S-3 |
| 60,000 | – | E70S-1B |
| 80 | E8018 | E80S-D2 |

Table 1.1 Recommended Electrodes and Wires

Amperage and voltage recommendations for welding are shown in Table 1.2 and Table 1.3

| POSITION | ELECTRODE SIZES (INCH) | WELDING CURRENT | | SPEED (INCH/MIN.) |
|-------------------------|------------------------|-----------------|-------|-------------------|
| | | AMPERES | VOLTS | |
| Flat | 0.125 | – | – | – |
| Horizontal and Vertical | 0.125 | 110/140 | 20/14 | 24 |

Table 1.2 SMAW Method (HSLA Frames)

| POSITION | ELECTRODE SIZES (INCH) | WELDING CURRENT | | SPEED (INCH/MIN.) |
|-------------------------|------------------------|-----------------|-------|-------------------|
| | | AMPERES | VOLTS | |
| Flat | 0.35 | – | – | 350/400 |
| Horizontal and Vertical | 0.35 | 190/220 | 20/30 | 350/400 |

Table 1.3 GMAW Method (HSLA Frames)

- 7) Preheat frame rail along the weld joint to 500 to 600° F (260 to 316° C) to insure any moisture present is eliminated and to prevent too rapid cooling of weld metal.
- 8) Direct current, reversed polarity is preferred. Weld using a short arc and a beading or narrow weave technique.
- 9) Slag should be removed after each pass and an interpass temperature of 200° F (93° C) should be maintained.
- 10) Grind smooth and flush with surrounding sidemember material. Grind the weld in a direction that is at 90° to crack direction (Figure .D).
- 11) Add reinforcement.

FRAMES

REPAIR AND REINFORCEMENT RECOMMENDED PROCEDURES

Heat Treated Frames (110,000 and 120,000 PSI Yield Strength)

When welding Heat Treated Frames (110,000 PSI and 120,000 Yield Strength), use low hydrogen electrodes which have superior crack resistance and notch toughness similar to AWS-E-11018. This type electrode should be stored in a moisture-free container to avoid porosity during welding. Amperage and voltage recommendations for welding are shown in Table 1.4.

| POSITION | AMPERES | VOLTAGE |
|-------------|---------|---------|
| Downhand | 130/140 | 21/23 |
| Overhand | 130/140 | 21/23 |
| Vertical Up | 110/120 | 22/24 |

Table 1.4 SMAW Method (Heat-treated Frames)

A heavy copper “chill” strip should be clamped to the rail side away from the groove to help control the temperature and cooling rate during welding (Figure). Short lengths of discarded heavy copper electrical bus bars make suitable chill strips. Preheat the frame rail along the crack area to 500-600° F (260-316° C). Either alternating current or direct current reversed polarity, combined with a short arc and a beading or narrow weave technique may be used. Direct current reversed polarity is recommended.

Slag should be removed after each pass and an interpass temperature of 200° F (93° C) should be maintained. Grind smooth and flush with surrounding sidemember material, in a direction that is parallel to the longitudinal axis of the sidemember (Figure .D). A V-groove is ground from the side opposite the repair and the procedure outlined above repeated. “Chill” strips should be used whenever possible. The V-groove ground on the opposite side of the repair should be deep enough to enter the sound metal of the first weld repair as shown in Figure .C.

Reinforcement

The strength of the sidemember in the weld joint repair region has been reduced by welding and this region must be reinforced sufficiently to insure that the service life of the frame is not shortened. Reinforcement of the frame after welding is intended to reduce the stresses in the weld repair region to a lower level than was previously permitted. Improper drilling will also reduce the strength of the sidemembers. Refer to “Drilling or Notching”.

The type, length, material and attachment techniques for reinforcements vary with the type and location of the crack and with the loading conditions associated with the crack. It is not practical to give specific recommendations for all cases of frame cracking, therefore the various types of reinforcements are identified with general descriptions of their applications and installation procedures. To aid in making the distinctions between the more critical flange area and the less critical web area, critical zones are defined as shown (Figure .D).

FRAMES

REPAIR AND REINFORCEMENT RECOMMENDED PROCEDURES

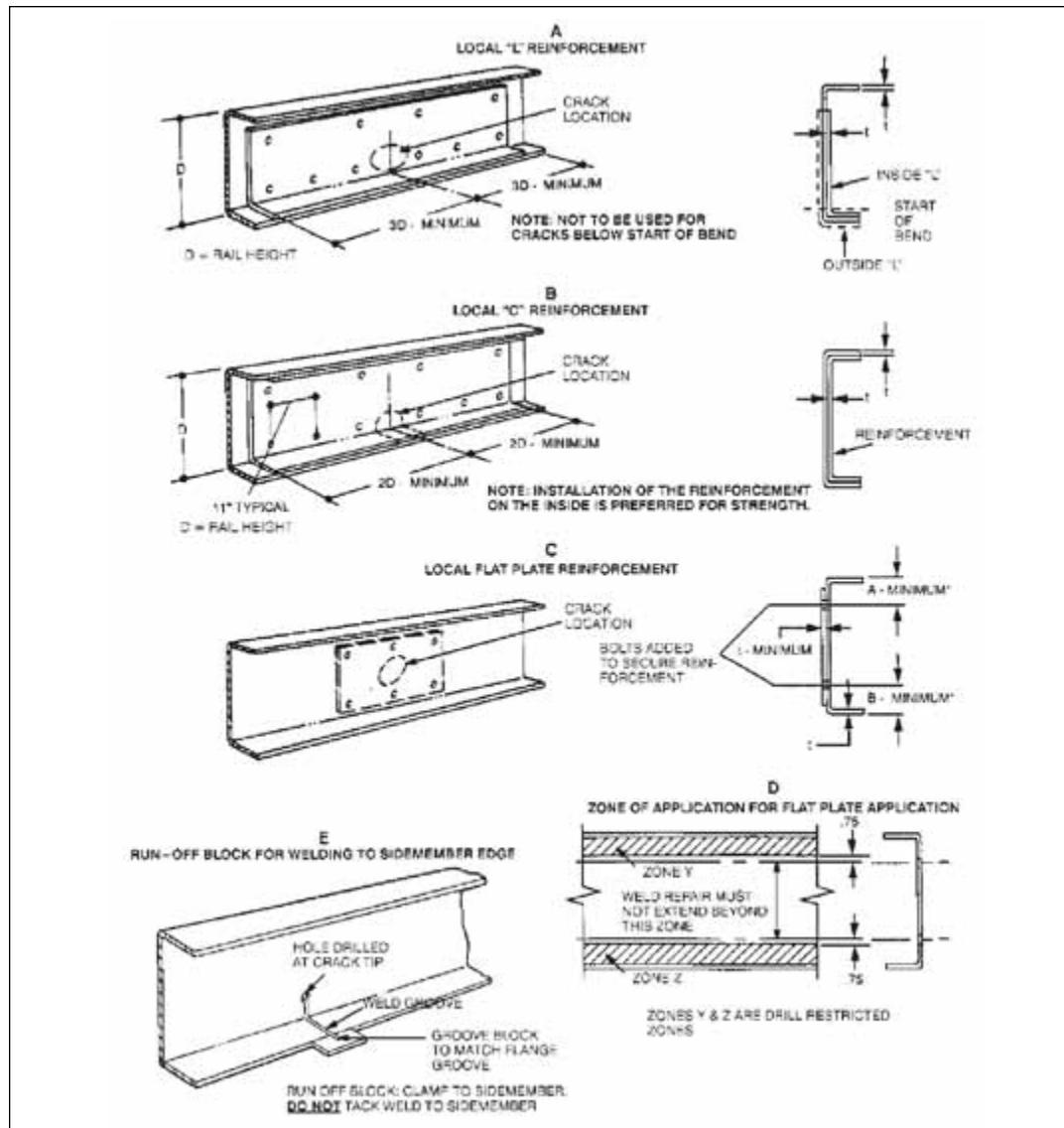

Figure 1.5 Reinforcement Application

FRAMES

REPAIR AND REINFORCEMENT RECOMMENDED PROCEDURES

Cracks which occur in the critical zones have a greater probability of growing vertically through the section, and the reduced strength after weld repair necessitates a more substantial reinforcement.

These guidelines potentially affect the structural integrity of the frame assembly and are intended for those who have the equipment and experience required to qualify as frame repair specialists.

General Weld Repair Reinforcement Procedures

- 1) The thickness and material strength of the local plate, "L" and channel reinforcements should match the section being reinforced.
- 2) The corners of the reinforcements which will be in contact with the sidemember along the reinforcement edges must be chamfered to prevent damage to the sidemember.
- 3) All sidemember reinforcements must be bolted to the web section within the zone shown in the frame drilling guidelines in the specific model body builder book. The bolts must be of SAE Grade 8 or better, with integral flanges or with hardened flat washers and must be tightened to Grade 8 levels.
- 4) Crossmember modification or replacement may be required if the reinforcement is on the same side as the crossmember.
- 5) Consider the potential effects of the reinforcements on the various components mounted to the frame. Check clearances for suspension, wiring, plumbing and other controls.
- 6) For attachment of reinforcements, use existing bolts wherever this is practical.
- 7) The weld repaired area of the sidemember and all of the reinforcement should be primed and painted before reinforcement installation. For corrosive environments, additional treatment of the interface may be needed.

Full Length Channel Weld Repair Reinforcements

"Full length" channel reinforcements are available through Cat® dealers for most models. The actual length, starting location and ending location vary from model to model. Different length reinforcements may also be available.

When applied as a repair reinforcement, these reinforcements DO NOT increase the load capacity of the vehicle. Their advantage in this case is their availability. A disadvantage of this type is that it is likely to affect more of the components which mount to the frame. In some cases this disadvantage may be offset by cutting the full length reinforcement to create a local reinforcement.

Recommended Applications

- 1) Cases of repair of vertical cracks in either the top or bottom flanges at very low mileage.
- 2) Cases in which the weld repair is accompanied by extensive straightening of heat treated sidemembers.

FRAMES

REPAIR AND REINFORCEMENT RECOMMENDED PROCEDURES

Full Length “L” Weld Repair Reinforcements

Steps 1 and 2 above also apply to the full length “L” reinforcements available from Caterpillar®. All of these are the inverted “L” type and are designed for installation on the outside of the sidemember section (except 9000 Series) (Figure .A).

Recommended Applications

This type of reinforcement is recommended for cases of cracking at very low mileage where a web crack has extended beyond the range for a flat plate reinforcement but ends short of the bend radius. It is also applicable to cases in which the cracking is accompanied by flange buckling.

Application Procedures

- 1) For custom-fabricated full length “L” reinforcements, the section should be oriented up or down so that the flange is on the same side as the damaged area.
- 2) For maximum strength the flange should be on the outside of the section.
- 3) Follow the general recommendations above for attachment of the reinforcement.

Local Channel Weld Repair Reinforcements

This type of reinforcement must be custom-fabricated either by cutting lengths from “full length” reinforcements or by forming from flat stock (Figure .B).

Recommended Applications

- 1) Cases in which the weld repair extends into the sidemember flange after substantial service life.
- 2) Cases accompanied by extensive abrasive wear of the sidemember section. In these cases the length of the wear area should be added to the length recommendations below.

Application Procedures

- 1) The channel should be installed on the outside of the section for greater strength.
- 2) Figure .B gives recommended dimensional data and attachment specifications for a typical installation. Holes drilled for the attachment must be within the frame drilling guidelines in the specific model body builder book.

FRAMES

REPAIR AND REINFORCEMENT RECOMMENDED PROCEDURES

Local “L” or Inverted “L” Weld Repair Reinforcements

This type of reinforcement is also generally custom-fabricated. It has a greater tendency to loosen than a channel reinforcement because, for vertical deflections of the frame assembly, it tends to bend about an axis different from that of the main sidemember section. Because of this its length and/or attachment specifications are typically greater than for the channel type.

Recommended Applications

This type of reinforcement is recommended for cases in which the weld repair is confined to the web of the section but extends beyond the application zone of the flat plate reinforcements shown in Figure .D.

Application Procedures

- 1) Figure .A shows a typical installation for an “L” reinforcement on the inside of a sidemember section along with minimum recommended dimensions.
- 2) The flange of the reinforcement should be oriented up or down so that flange is on the same side as the damaged area.
- 3) For maximum strength the reinforcement should be installed on the outside of the sidemember section.

Flat Plate Weld Repair Reinforcements

This reinforcement is intended for the less critical, web portion of the sidemember section where typical cracking is due to local stresses which tend to “diaphragm” or “dish” the web without creating appreciable stresses for overall bending of the section. Typical crack patterns radiate out from the edge of a mounting bracket or crossmember or from a hole in the web. Cracks which radiate from a web hole occupied by a fastener are frequently an indication of a defective joint, whether by the loosening of the fastener or poor joint design (Figure .C).

Recommended Applications

The flat plate reinforcements are recommended for weld repairs in which the weld does not extend beyond the zone defined in Figure .D.

Application Procedures

- 1) A typical installation is shown in Figure .C. The length and height of the plate will vary with the size of the weld repair area. In general it should be such that it will accommodate an array of reinforcement attachment bolts at a typical 3 to 5 inch (76 to 127 mm) spacing all around the weld repair area.
- 2) The plate should generally be installed on the side opposite the component which transferred the local bending load into the web.
- 3) The edges of the plate should be staggered with respect to the edges of other relatively stiff web mounted components to avoid the creation of stress concentrations.

FRAMES

BOLT AND TORQUE INFORMATION

Most frames are assembled with bolts and nuts. Others are riveted. **Bolts must always be used when attaching a reinforcement.** Rivets should be replaced by bolts as required when the frame is repaired and reinforced.

In bolted joints, the majority of the load is transferred by frictional force or clamping force between the members of the joint. The bolts must be properly tightened to develop and maintain the desired clamping force. Operation of the joint with loose or improperly tightened bolts can lead to failure of the joint. The bolts and nuts should be inspected periodically to insure that proper torque is maintained.

Bolts of high strength material conforming to SAE Grade 8 bolts should be used on all frames. For installation of reinforcements, 0.5 inch (13 mm) diameter flange head bolts are recommended. The SAE Grade 8 bolt is identified by six radial line markings on the head of the bolt (Figure 1.6). Nuts must be Grade 8 flange type.

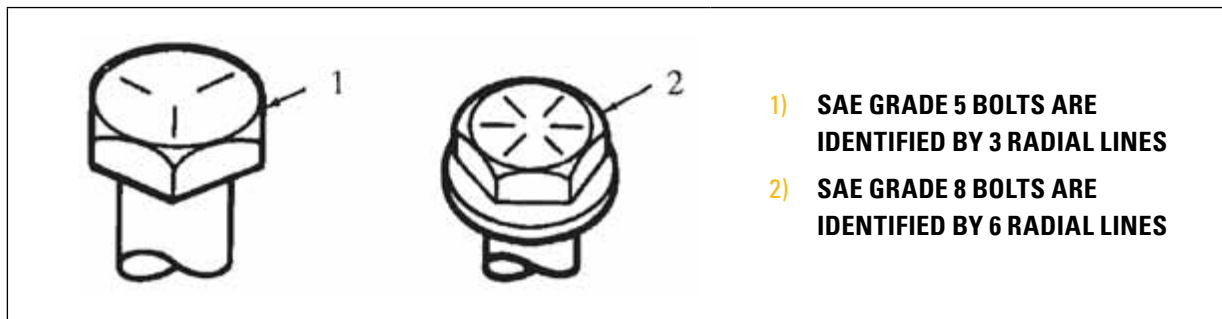

Figure 1.6 Bolt Identification

These bolts, 0.5 inch (13 mm) diameter flange head type, should be tightened to 110 to 120 ft-lbs. (149 to 163 Nm) based on new bolts and nuts lubricated with engine oil. Whenever possible, hold the bolt and tighten the nut. If frame components are aluminum, flange head bolts and nuts, or bolts with hardened flat washers must be used. If modification or repair requires replacement of existing bolts with new bolts or bolts of a greater length, the old flange head nuts should not be used with new standard bolts.

Careful consideration is given to the number, location and sizes of frame bolt holes in the design of a vehicle. The number, location and sizes of additional bolt holes put in the frame subsequent to manufacture of the vehicle can adversely affect frame strength. The adverse effect of additional bolt holes can be minimized by following the guidelines.

FRAMES

BOLT AND TORQUE INFORMATION — HUCKBOLT FASTENERS (HP 8)

Huckbolt HP 8 fasteners are used in various positions in frame rail construction. Advantages to this style fastener are consistent clampload and a high resistance to loosening due to vibration. The need to recheck fastener torque is eliminated.

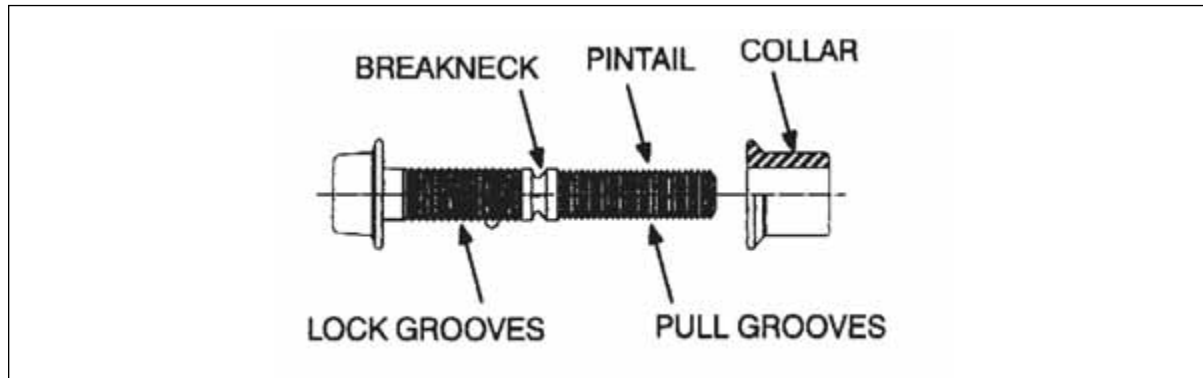

Figure 1.7 Huckbolt Fasteners

Removal

The swaged collar cannot be unscrewed due to the locking grooves on the HP 8 fastener. Removal requires a Huck Collar Cutter or the collar can be split with an air chisel while supporting the opposite side of the collar. When the collar is split, the fastener can be driven out with a punch.

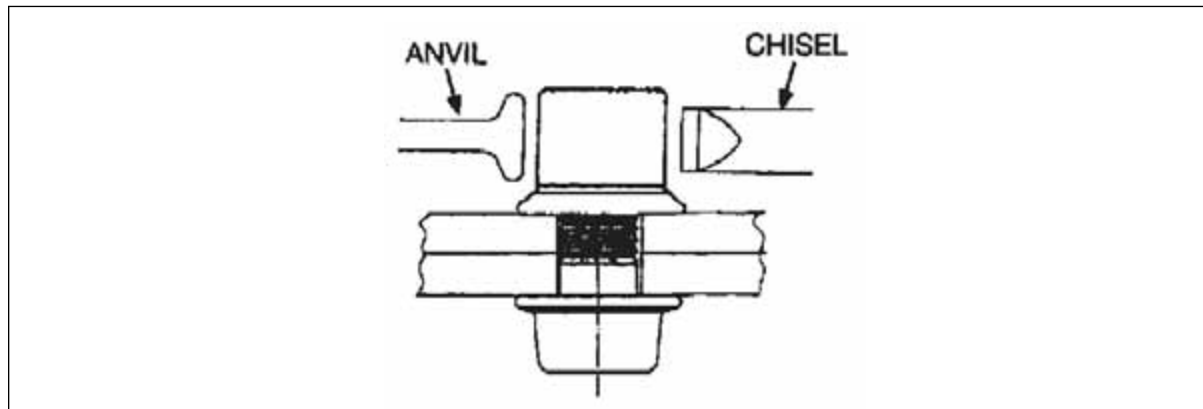

Figure 1.8 Collar Can Be Split With an Air Chisel

FRAMES

BOLT AND TORQUE INFORMATION — HUCKBOLT FASTENERS (HP 8)

Installation

NOTE: Huckbolt HP 8 fasteners cannot be installed without Huck installation equipment.

- 1) Install the HP 8 fastener into the component and frame hole.
- 2) Place the collar over the fastener pintail (See Figure 1.9)

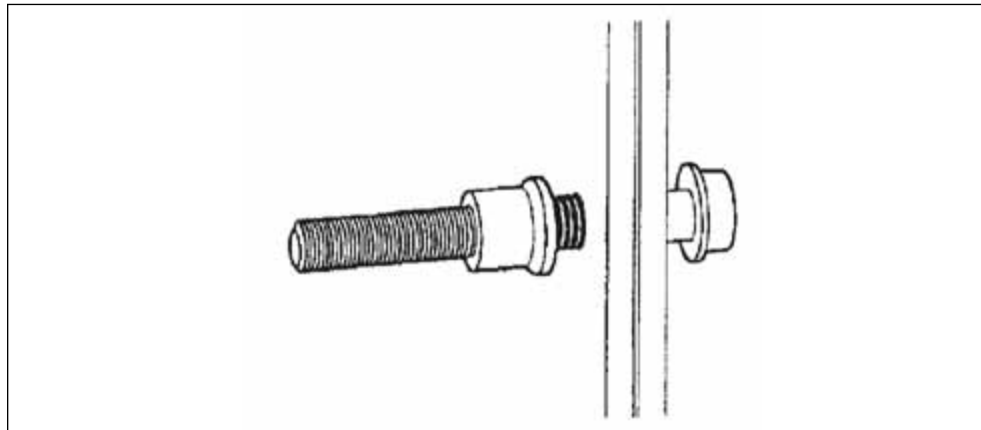

Figure 1.9 Place Collar Over Fastener Pintail

CAUTION: The HP 8 fastener is not intended for re-use. To do so can result in damage to the vehicle frame or components attached to the frame.

CAUTION: In the event that Huck fasteners are removed, in order to retain the same joint integrity, it is strongly recommended that new Huck fasteners be used for attachment/reattachment of components.

FRAMES

BOLT AND TORQUE INFORMATION — HUCKBOLT FASTENERS (HP 8)

- 3) Place the Huck installation tool over the HP 8 fastener pintail (See Figure 1.10)

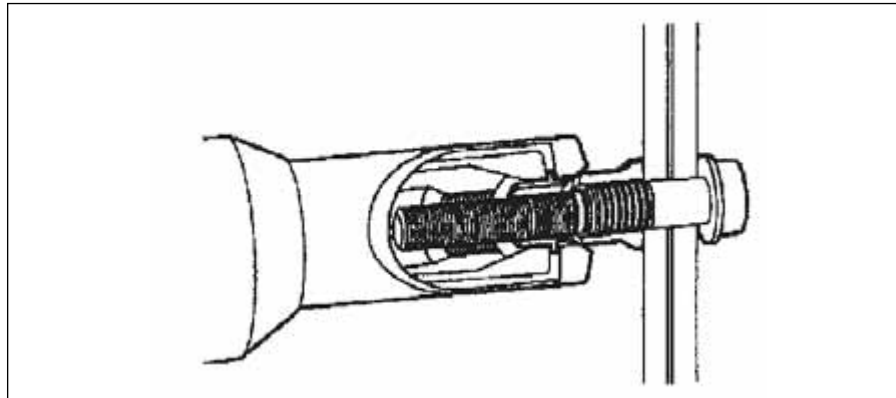

Figure 1.10 Place Installation Tool Over Fastener Pintail

- 4) Activate the Huck installation tool.

NOTE: The Huck installation tool creates a pulling force on the fastener, seating the bolt head and closing the gap between the mating surfaces. The collar is swaged into the pintail locking grooves developing clamping force (See Figure 1.11). As pulling forces further increase, the body of the fastener separates at the breakneck (See Figure 1.12), completing installation.

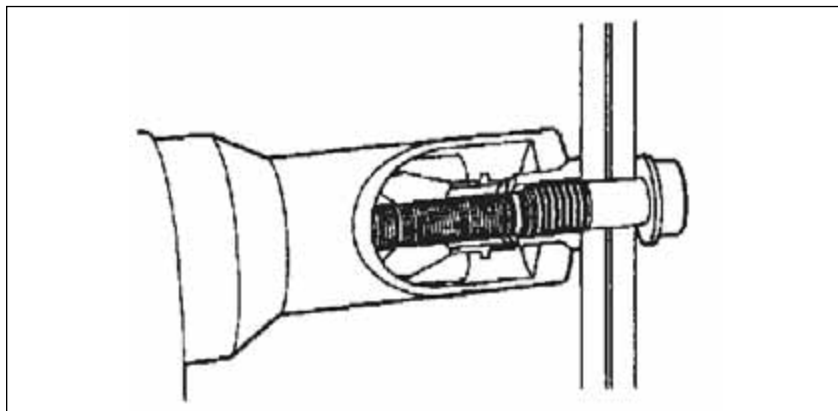

Figure 1.11 Clamping Force is Developed

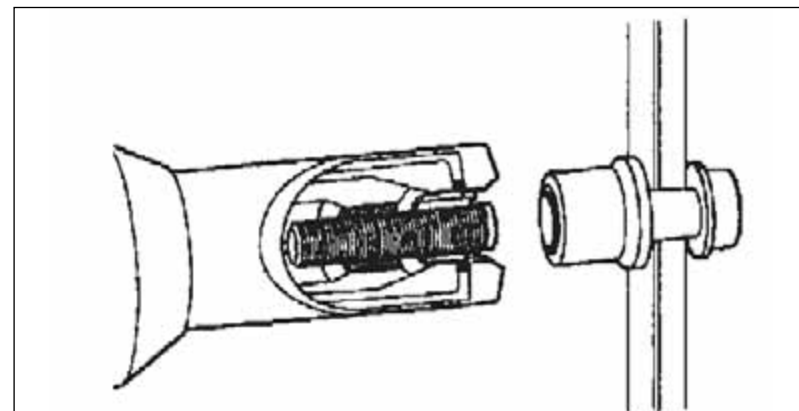

Figure 1.12 Body of Fastener Separates at Breakneck

FRAMES

BOLT AND TORQUE INFORMATION — HUCK-SPIN FASTENERS

Description

Huck-Spin fasteners are used in various positions in frame rail construction. The installed fastener has a collar that is cold-worked or swaged over the grooved pin Figure 1.13. Advantages to this style fastener are consistent clamp load and a high resistance to loosening due to vibration. The need to recheck fastener torque is eliminated.

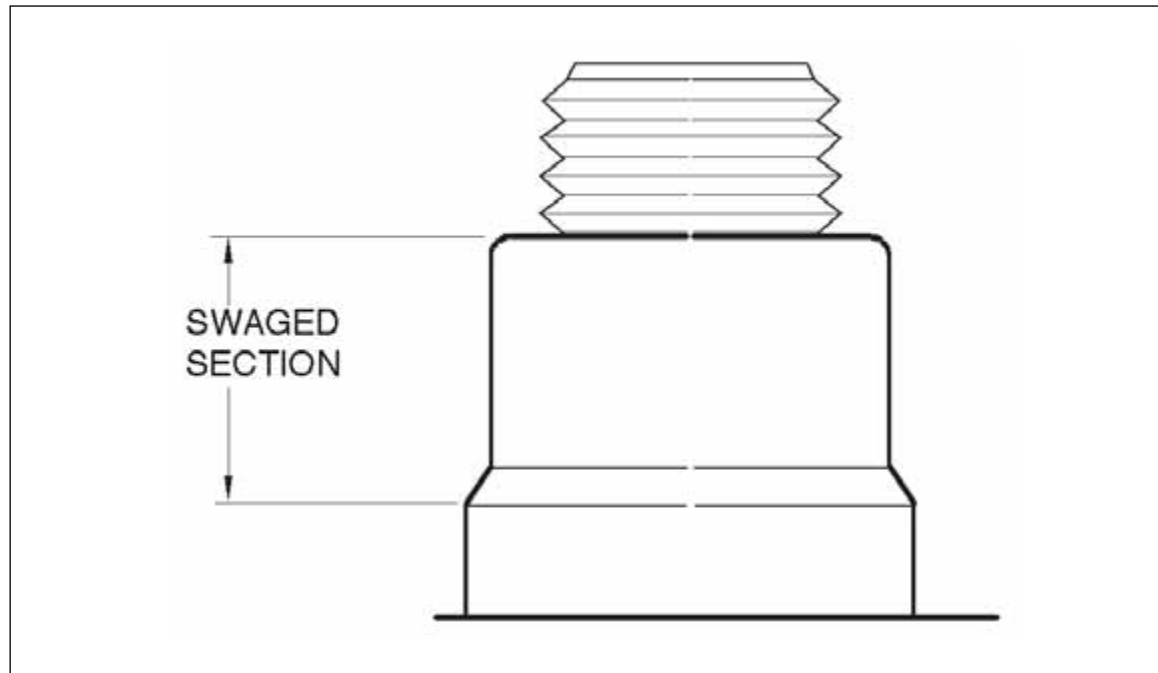

Figure 1.13 Huck-Spin Collar

FRAMES

BOLT AND TORQUE INFORMATION — HUCK-SPIN FASTENERS

Remove

The collar cannot be removed by twisting or hammering. The collar must be cut longitudinally to the extent of the swaged section. This can be accomplished with a small wheel grinder (Figure 1.14).

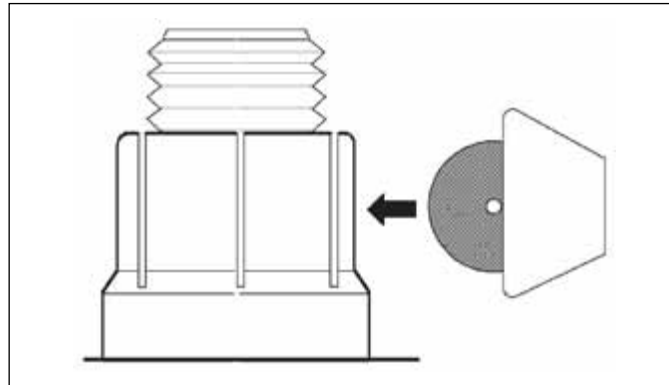

Figure 1.14 Cutting Collar with Wheel Grinder

Drilling on opposite sides of the collar may also be used (Figure 1.15).

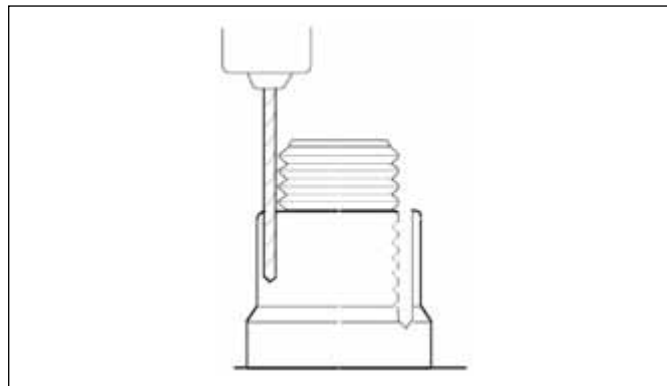

Figure 1.15 Drilling the Collar

Another method of splitting the collar is to chisel the walls of the collar (Figure 1.16).

FRAMES

BOLT AND TORQUE INFORMATION — HUCK-SPIN FASTENERS

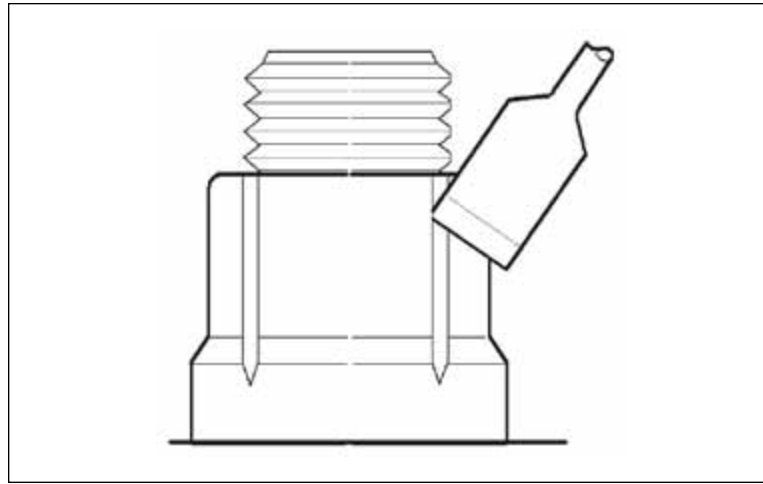

Figure 1.16 Using a Chisel to Split the Collar

When the collar has been opened over the length of the swaged portion on two opposite sides (Figure 1.17), the fastener can be removed. The fastener may need to be hammered to remove the collar.

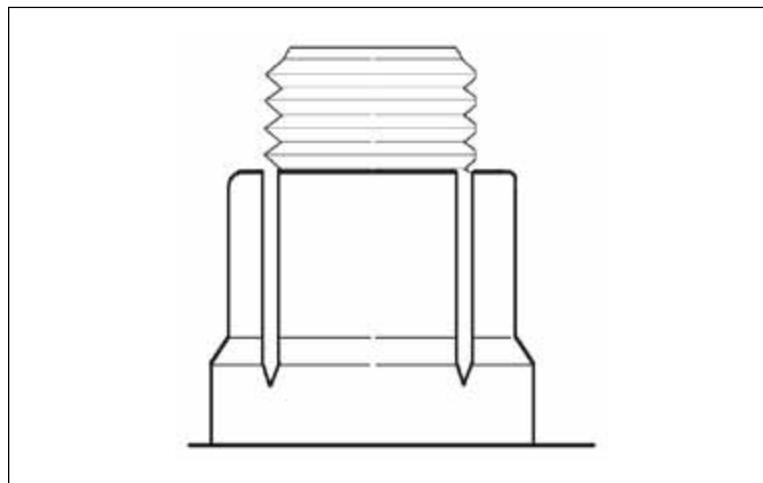

Figure 1.17 Collar with Reliefs for Removal

FRAMES

BOLT AND TORQUE INFORMATION — HUCK-SPIN FASTENERS

In the event the collar doesn't come loose, use a chisel or suitable tool to peel the collar sections back (Figure 1.18).

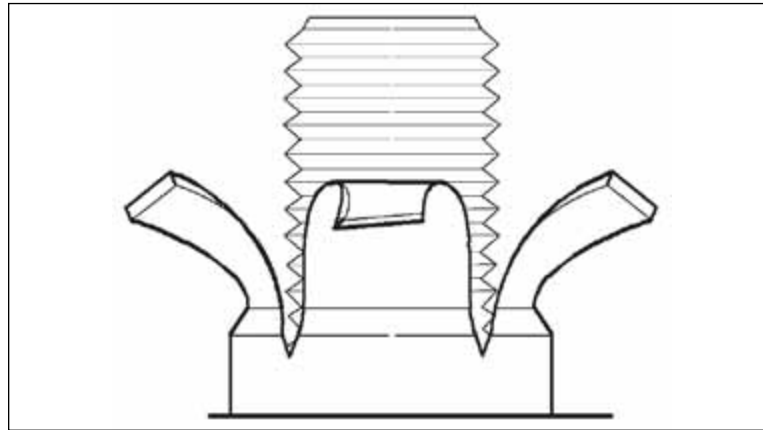

Figure 1.18 Collar Peeled Back to Assist Removal

The fastener will come free when sufficient collar material has been pulled away (Figure 1.19).

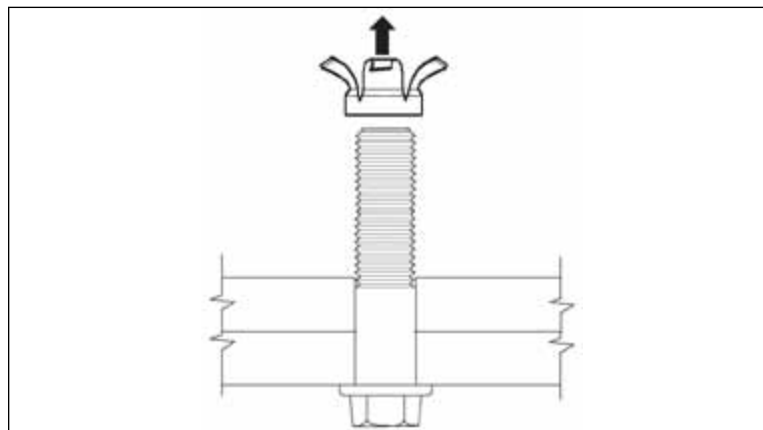

Figure 1.19 Fastener Removed

FRAMES

BOLT AND TORQUE INFORMATION — HUCK-SPIN FASTENERS

Install

The Huck-Spin is installed by spinning the collar onto the fastener. The pulling action of the Huck-Spin installation tool swages the collar into the grooves of the fastener and then automatically disengages from the fastener (Figure 1.20).

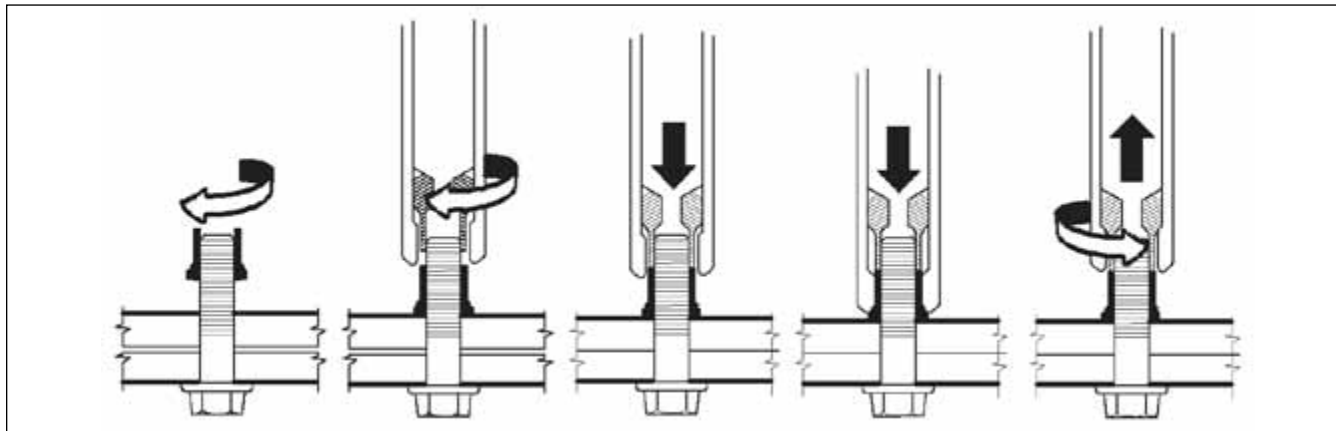

Figure 1.20 Huck-Spin Installation

FRAMES

SPECIAL SERVICE TOOLS — HYDRAULIC UNIT (MODEL NO. 940)

Used for removal and installation of the Huck Bolt.

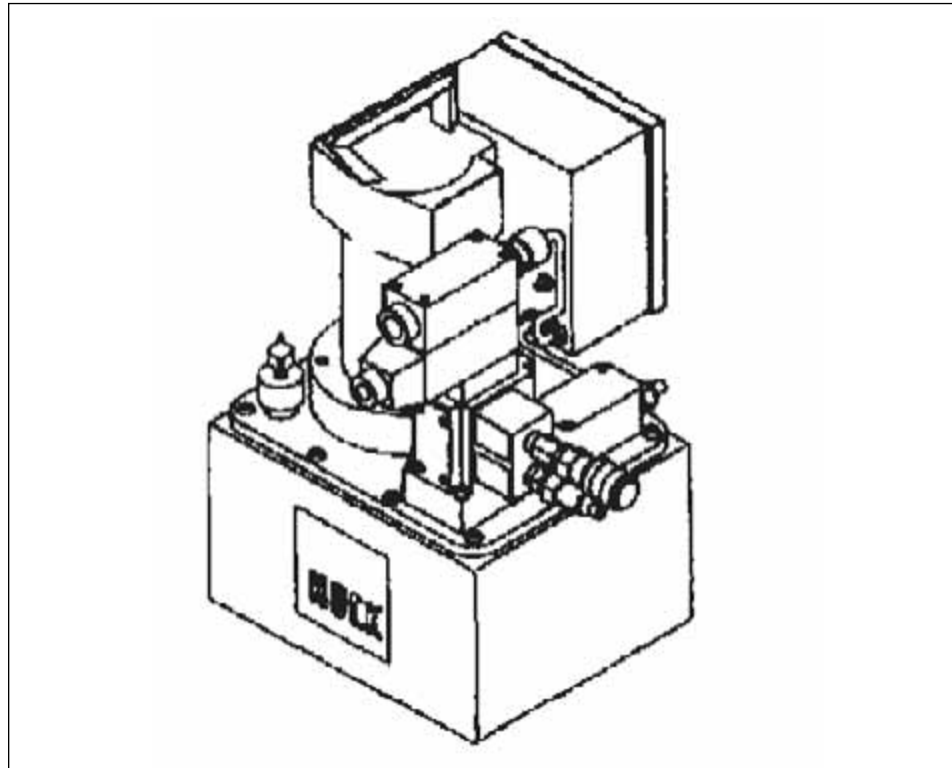

Figure 1.21 Hydraulic Unit

FRAMES

SPECIAL SERVICE TOOLS — NOSE ASSEMBLY TOOL

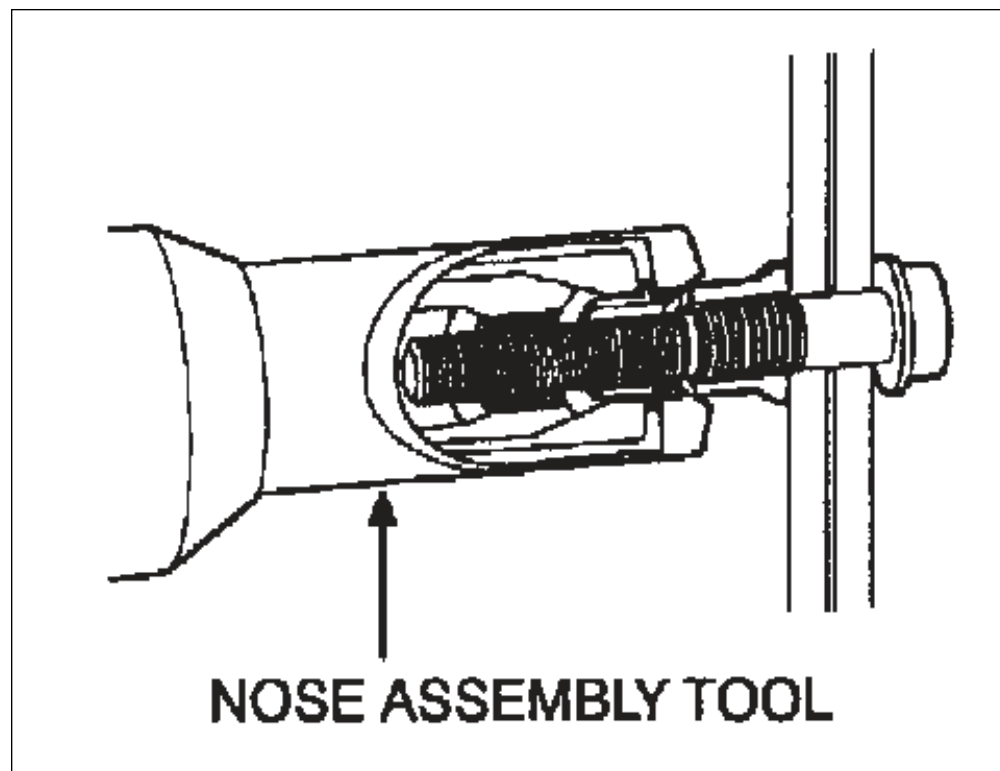

Figure 1.22 Nose Assembly Tool

| DESCRIPTION | TOOL NUMBER |
|-----------------------|-------------|
| For 1/2 Dia. Fastener | 99-1484 |
| For 5/8 Dia. Fastener | 99-1481 |

Table 1.5 Nose Assembly Tool

FRAMES

SPECIAL SERVICE TOOLS — HYDRAULIC INSTALLATION TOOL

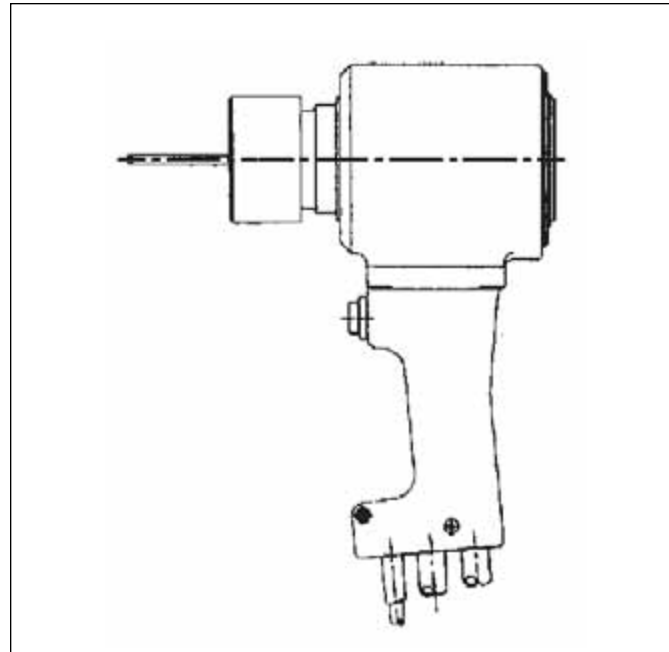

Figure 1.23 Hydraulic Installation Tool

| DESCRIPTION | TOOL NUMBER |
|------------------------|-------------|
| For 1/2 Dia. Fasteners | 557 |
| For 5/8 Dia. Fasteners | 585 |

Table 1.6 Hydraulic Installation Tool

| DESCRIPTION | TOOL NUMBER |
|------------------------|-------------|
| For 1/2 Dia. Fasteners | 516 |
| For 5/8 Dia. Fasteners | 520 |

Table 1.7 Collar Removal Tool

FRAMES

AFTERMARKET MODIFICATIONS

Cutting the frame behind the rear axle to shorten the frame is acceptable. Mechanical cutting or sawing is preferred to torch cutting. Whenever it is necessary to cut the frame, the sidemember should be cut at an angle of 90° to the longitudinal axis.

For information on cutting of the frames to lengthen the frames or modify the wheelbase, refer to “Wheelbase Alterations”.

Where mounting angles are to be welded to fifth wheel assemblies, refer to fifth wheel manufacturer’s recommendations. In some cases, specialized equipment such as hoists, winches, lifts, snowplows, pusher and tag axles are added to the vehicle by distributors, installers or dealers. Unless otherwise specified by the customer at the time of assembly, the vehicle is generally equipped with a standard chassis frame and the manufacturer has not made special allowances for the special equipment which is being added.

The addition or installation of this special equipment on the vehicle can significantly affect the loading of the chassis frame. In some cases, it may be necessary to reinforce the frame. Care must be exercised to insure that the gross vehicle weight rating (GVWR) and/or the gross axle weight ratings (GAWR) are not exceeded.

Installation of this special equipment may involve State and Federal requirements which affect vehicle certification for noise emissions, exhaust emissions, brake requirements, lighting system requirements, etc. The specialized equipment installer is responsible for the safety and durability of their product and, in addition, is responsible to insure that the equipment and its installation comply with all applicable State and Federal Department of Transportation requirements and OSHA regulations.

Addition of specialized equipment may have a significant effect on other vehicle components, such as the brake system, steering system, suspension system, etc. Simple reinforcement of the chassis frame may not be adequate to provide safe operation of the vehicle. In any modification of the chassis frame, the addition of holes, reinforcements, welds, clamps, splices, etc. may cause an increase in the local stress in the frame at the point of the modification. These local stress concentrations can significantly affect the life of the chassis frame. The specific effect which the stress concentrator will have on the life of the chassis frame is influenced by the location of the stress concentration, the frequency and severity of the loading, and the type of stress concentration. Any modification of the frame may void the manufacturer’s warranty.

Refer to “Welding and Reinforcement” information.

FRAMES

AFTERMARKET MODIFICATIONS

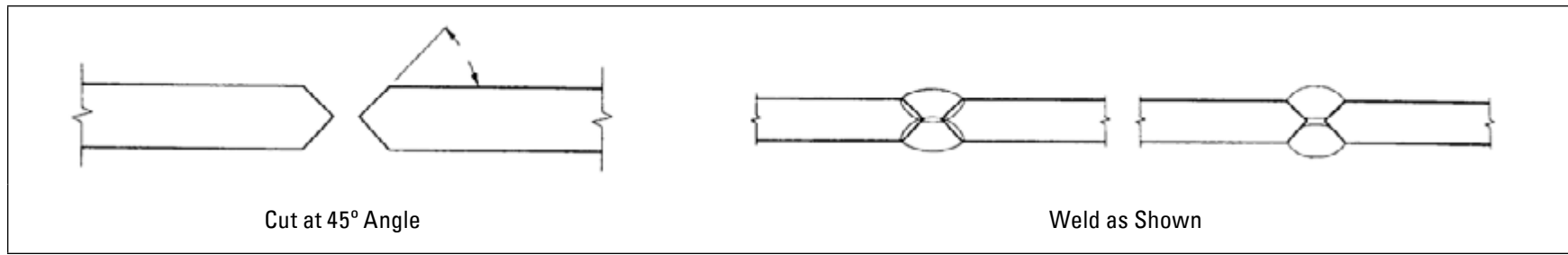

Figure 1.24 Frames – Preparation of Joint for Welding Extension

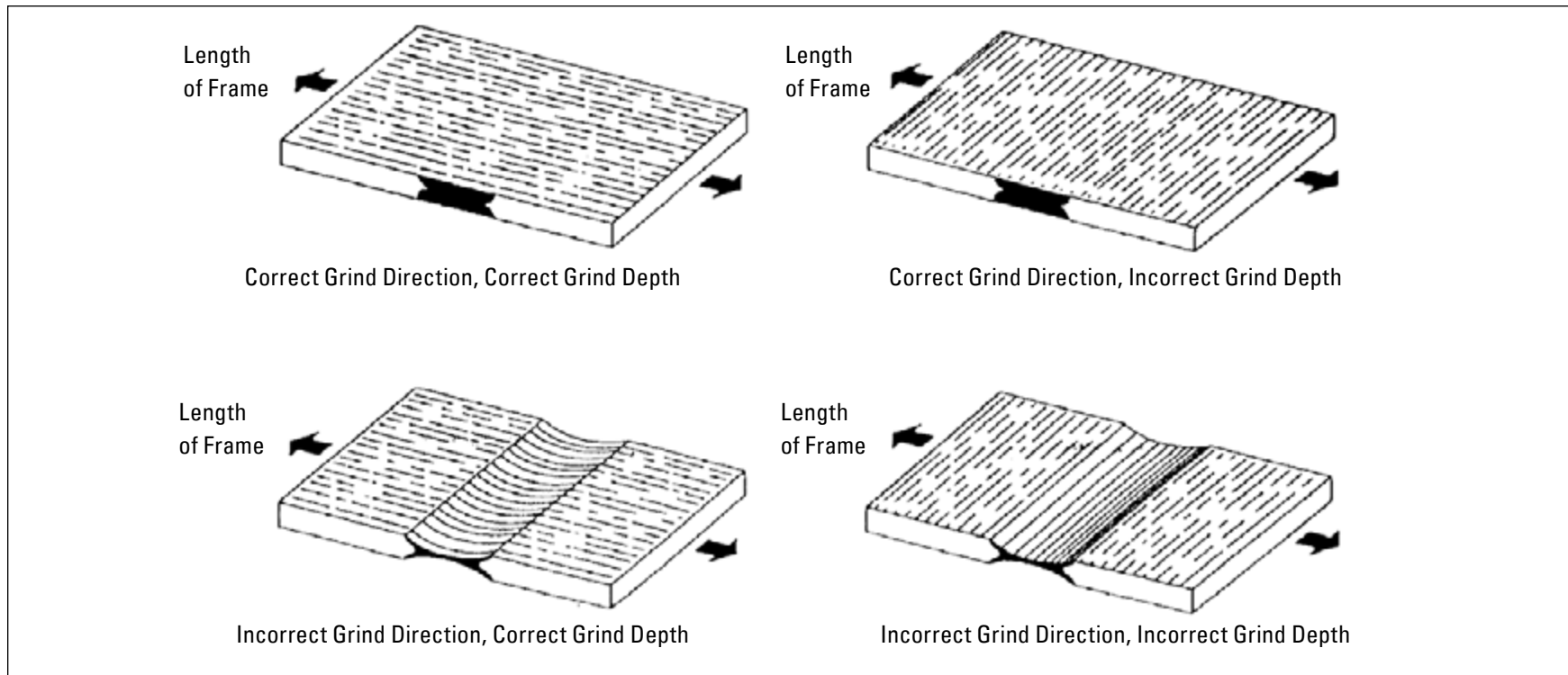
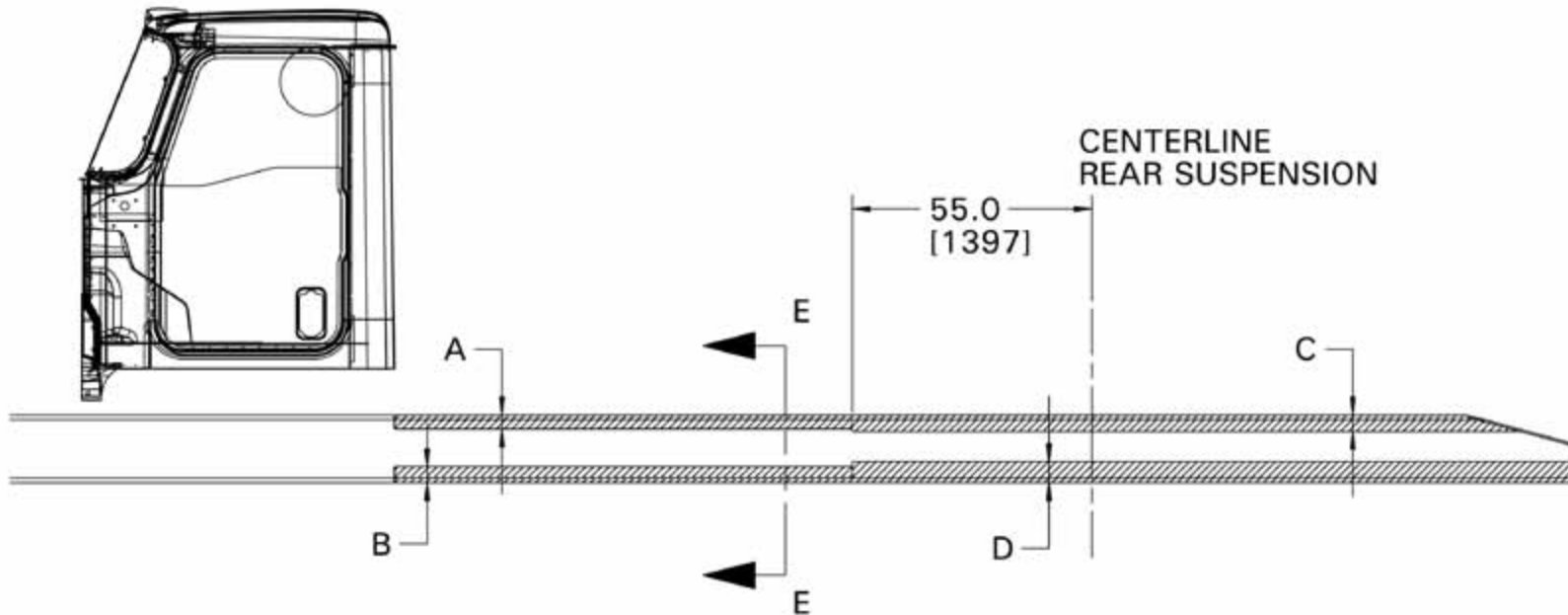

Figure 1.25 Cross-sectional Views Showing Correct and Incorrect Methods of Finishing the Joint

FRAMES

FRAME DRILLING RESTRICTIONS — TRACTOR



Do not leave less than 0.75" (19mm) of material between holes.

Do not drill holes in the following areas:

CAUTION: Do not weld or drill the top or bottom flanges of the vehicle frame.

Welding or drilling the flanges will severely weaken the frame.

| A | B | C | D |
|----------|----------|----------|----------|
| 1.6 (41) | 2.0 (51) | 2.0 (51) | 2.3 (58) |
| [1] | [2] | [1] | [2] |

[1] Distance from top of top flange to centerline hole

[2] Distance from bottom of bottom flange to center line of hole

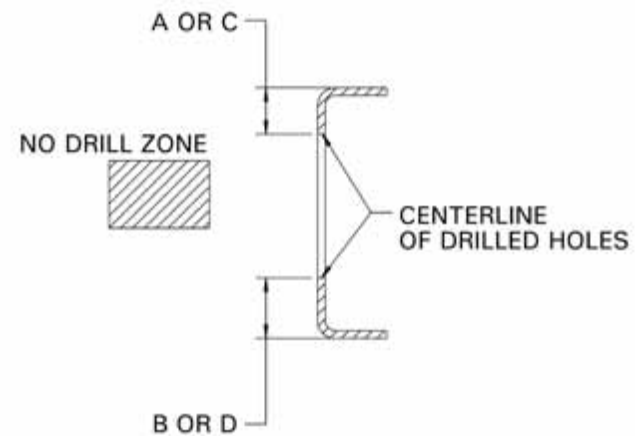

SECTION E - E

[↶ return to table of contents](#)

FRAMES

FRAME DRILLING RESTRICTIONS — TRUCK

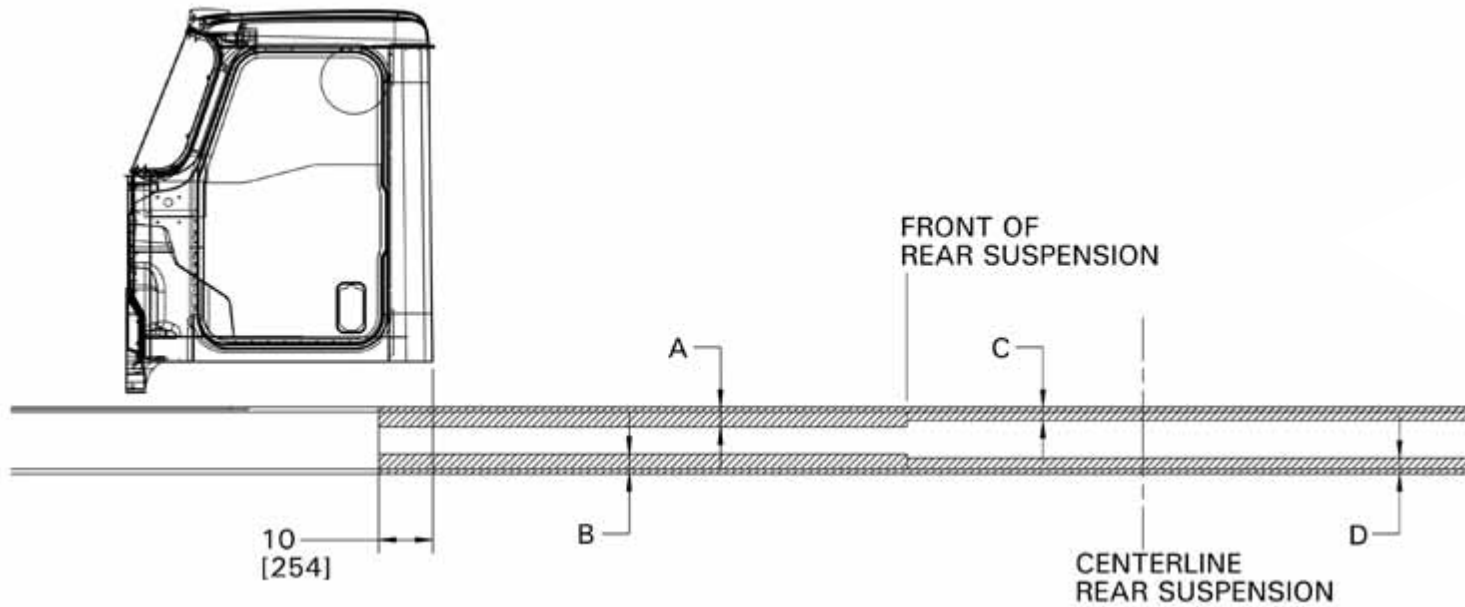

Do not leave less than 0.75" (19mm) of material between holes.
Do not drill holes in the following areas:

| A | B | C | D |
|-----------|-----------|----------|----------|
| 2.75 (70) | 2.75 (70) | 1.6 (41) | 2.0 (50) |
| [1] | [2] | [1] | [2] |

[1] Distance from top of top flange to center line hole
[2] Distance from bottom of bottom flange

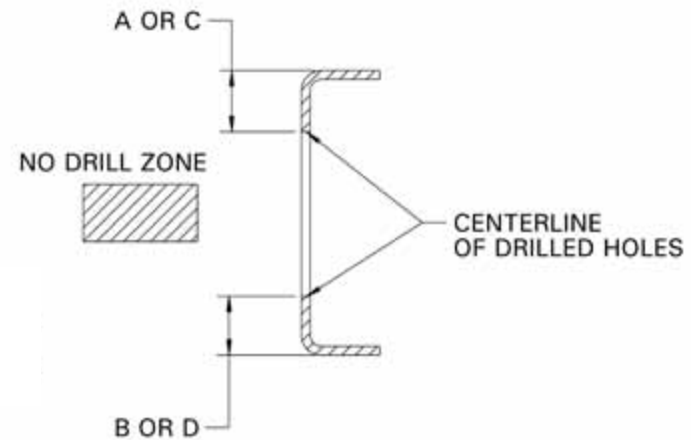

↶ return to table of contents

FRAMES

WHEELBASE ALTERATIONS

Shortening or lengthening a wheelbase is an added expense for the customer. Therefore, it is often to the customer's benefit to order a chassis from the factory with the desired wheelbase rather than to alter the wheelbase of the chassis on-site. The preferred method for altering the wheelbase is to slide the rear axle forward or rearward as required. Invariably, this requires the lengthening or shortening of air lines, brake lines, electrical lines, and driveline. Extreme care should be taken in the modification of the air lines, brake lines, electrical lines and driveline to insure that they operate as reliably as those with which the vehicle was manufactured.

If the wheelbase is lengthened, a reinforcement may be required. Consult your Cat® dealer before lengthening the wheelbase. In those instances when it is necessary to cut and weld the frame to alter the wheelbase, the frame must be reinforced with a channeltype reinforcement of the same strength as the original frame material in the area where the frame has been cut, extending at least two feet on either side of the cut and bolted as specified in Figure .D shown earlier in this section.

If the frame was built with both a main frame and a reinforcement, the reinforcement should be removed before cutting the main frame. **It is essential that a new one-piece outer channel reinforcement be obtained rather than cutting and re-using the original reinforcement.** The original frame should also be reinforced with an inner channel reinforcement, extending at least two feet beyond the cut(s) on either side of the cut(s). The reinforcement must be of the same material as the original frame. Blank and pre-punched chassis channel reinforcements are available through your dealer parts department.

On both medium and high strength aluminum frames, **re-welding to lengthen the frame is not recommended.** Refer to "Reinforcement" and "Reinforcement Attachment" for additional information.

FRAMES

MAXIMUM WHEELBASE AVAILABLE — 660S & 660L WHEELBASE AVAILABILITY

| DIMENSIONS | CODE | FRONT AXLES | GVWR | MAXIMUM WHEELBASE | | | | | | | | | | | | | | | | | | | | | | | |
|--|--------------------|-------------|---------|-------------------|-----|-----|-----|-----|-----|-----|-----|-----|-----|-----|-----|-----|-----|-----|-----|-----|-----|-----|-----|-----|-----|-----|--|
| | | | | 140 | 150 | 160 | 170 | 180 | 190 | 200 | 210 | 220 | 230 | 240 | 250 | 260 | 270 | 280 | 290 | 300 | 310 | 320 | 330 | 340 | 350 | 360 | |
| 12.25 x 3.375 x .375 | 0001CDH | 12K | <=52K | 331" (8400mm) | | | | | | | | | | | | | | | | | | | | | | | |
| | | 13.2K | <=53.2K | 329" (8350mm) | | | | | | | | | | | | | | | | | | | | | | | |
| | | 14-14.6K | <=60.6K | 280" (7100mm) | | | | | | | | | | | | | | | | | | | | | | | |
| | | 16K | <=62K | 260" (6600mm) | | | | | | | | | | | | | | | | | | | | | | | |
| | | 18K | <=64K | 246" (6250mm) | | | | | | | | | | | | | | | | | | | | | | | |
| | | 20K | <=85 | 234" (5950mm) | | | | | | | | | | | | | | | | | | | | | | | |
| | | 21-22K | <=87K | 222" (5650mm) | | | | | | | | | | | | | | | | | | | | | | | |
| | | 23K | <=88K | 215" (5450mm) | | | | | | | | | | | | | | | | | | | | | | | |
| 12.0 x 3.25 x .25 w/.25 Outer Reinforcement | 0001DAV 0001GDL | 12K | <=52K | 360" (9150mm) | | | | | | | | | | | | | | | | | | | | | | | |
| | | 13.2K | <=53.2K | 360" (9150mm) | | | | | | | | | | | | | | | | | | | | | | | |
| | | 14-14.6K | <=60.6K | 358" (9100mm) | | | | | | | | | | | | | | | | | | | | | | | |
| | | 16K | <=62K | 325" (8250mm) | | | | | | | | | | | | | | | | | | | | | | | |
| | | 18K | <=64K | 299" (7600mm) | | | | | | | | | | | | | | | | | | | | | | | |
| | | 20K | <=98 | 293" (7450mm) | | | | | | | | | | | | | | | | | | | | | | | |
| | | 21-22K | <=100K | 276" (7000mm) | | | | | | | | | | | | | | | | | | | | | | | |
| | | 23K | <=101K | 266" (6750mm) | | | | | | | | | | | | | | | | | | | | | | | |
| 12.25 x 3.375 x .375 w/.313 Outer Reinforcement | 0001CDH 0001GDM | 12K | <=52K | 360" (9150mm) | | | | | | | | | | | | | | | | | | | | | | | |
| | | 13.2K | <=53.2K | 360" (9150mm) | | | | | | | | | | | | | | | | | | | | | | | |
| | | 14-14.6K | <=60.6K | 360" (9150mm) | | | | | | | | | | | | | | | | | | | | | | | |
| | | 16K | <=62K | 360" (9150mm) | | | | | | | | | | | | | | | | | | | | | | | |
| | | 18K | <=64K | 352" (8950mm) | | | | | | | | | | | | | | | | | | | | | | | |
| | | 20K | <=98 | 317" (8050mm) | | | | | | | | | | | | | | | | | | | | | | | |
| | | 21-22K | <=100K | 309" (7850mm) | | | | | | | | | | | | | | | | | | | | | | | |
| | | 23K | <=101K | 301" (7650mm) | | | | | | | | | | | | | | | | | | | | | | | |

↶ return to table of contents

FRAMES

FRAME RAIL SPECIFICATIONS/CROSS-SECTIONS

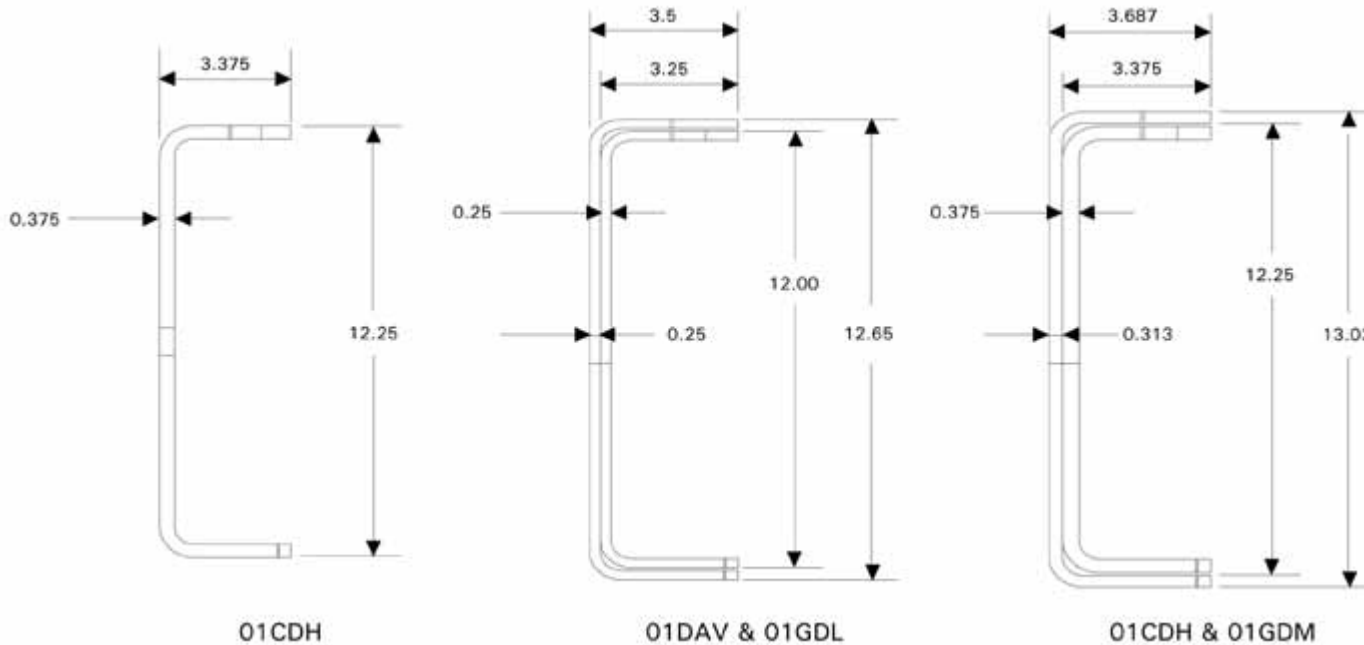

| SIDE RAIL DESCRIPTIONS | | | | | | | |
|------------------------|--------------------|--------------|--------------|----------------------|--|--|-----------------------------------|
| FRAME CODE | DIMENSION (INCHES) | | | YIELD STRENGTH (PSI) | MOMENT OF INERTIA (INCHES ⁴) | SECTION MODULUS (INCHES ³) | RESISTING BENDING MOMENT (IN-LBS) |
| | DEPTH | WIDTH | THICKNESS | | | | |
| 0001CDH | 12.25 | 3.375 | 0.375 | 120,000 | 128.66 | 21.0 | 2,520,000 |
| 0001DAV | 12.00 | 3.25 | 0.25 | 120,000 | 182.29 | 28.82 | 3,458,580 |
| 0001GDL | 12.65 | 3.50 | 0.25 | 120,000 | | | |
| 0001CDH | 12.25 | 3.375 | 0.375 | 120,000 | 264.07 | 40.45 | 4,865,748 |
| <i>0001GDM</i> | <i>13.03</i> | <i>3.687</i> | <i>0.313</i> | <i>120,000</i> | | | |

NOTE: Reinforcement dimensions and specifications are shown in italics.

FRAMES

FRAME RAIL REINFORCEMENT

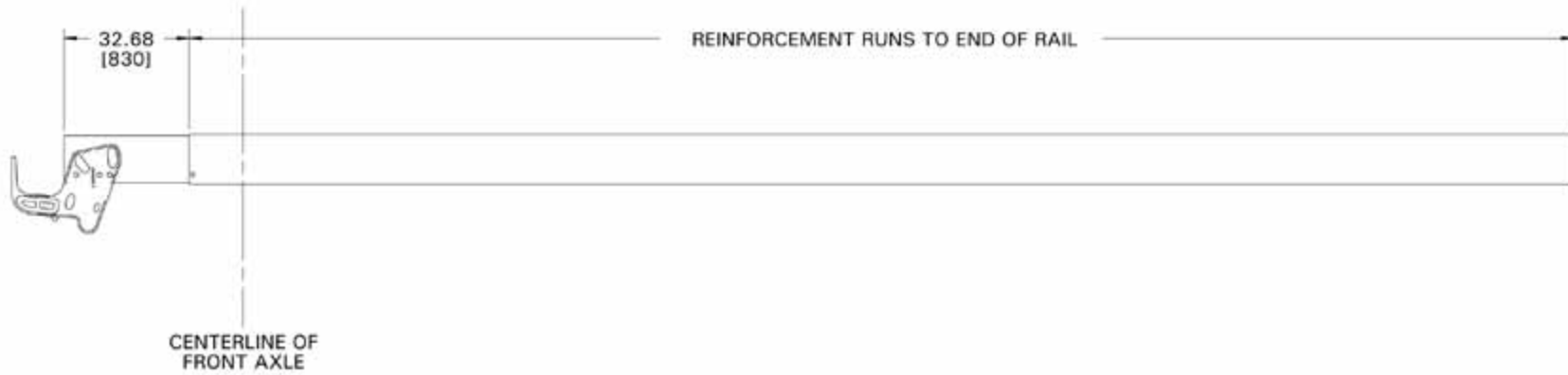

FRAMES

INTERMEDIATE/AF CROSSMEMBERS

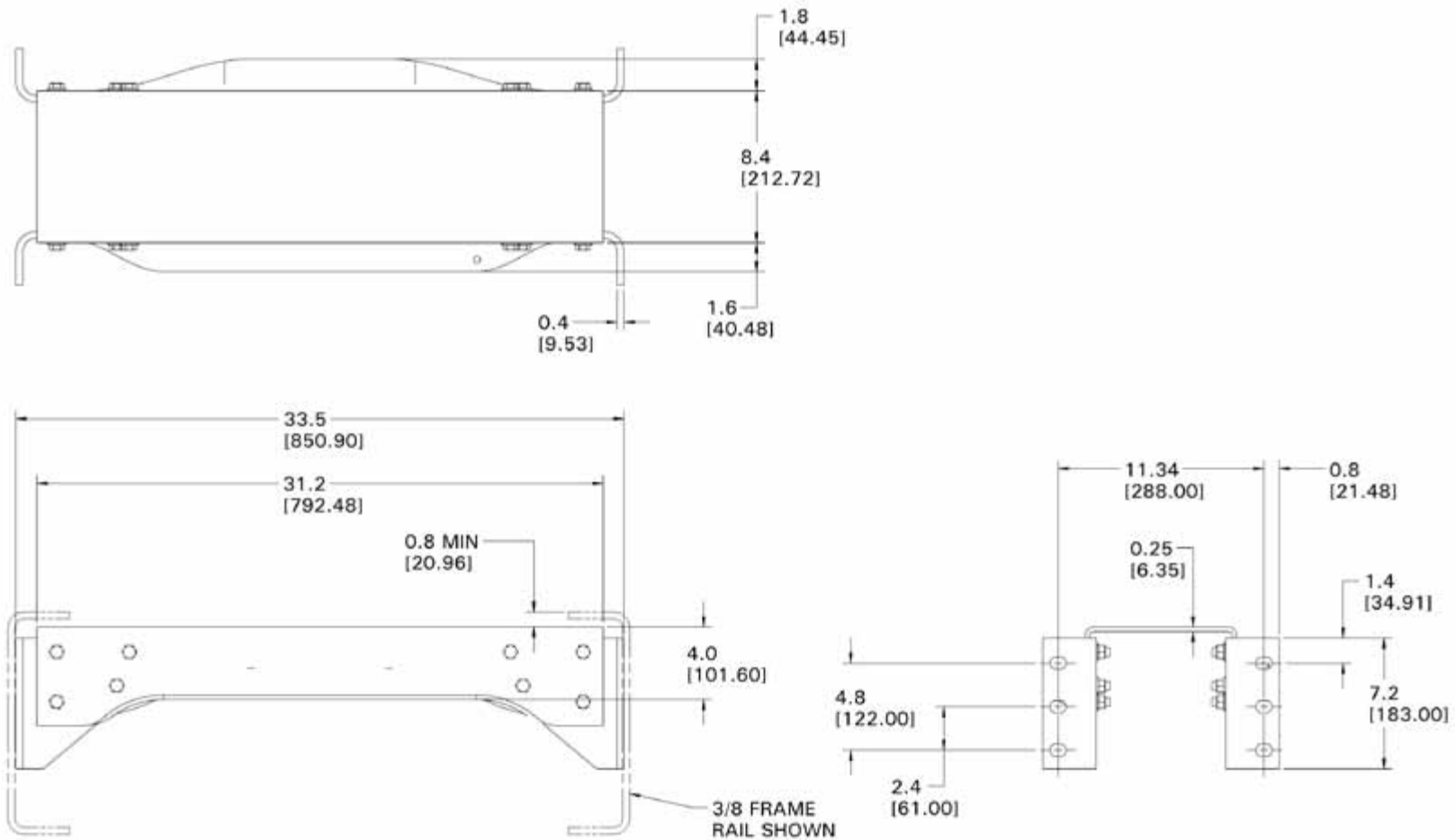

FRAMES

REAR CROSSMEMBERS

0001652 OPTIONAL
AF CROSSMEMBER

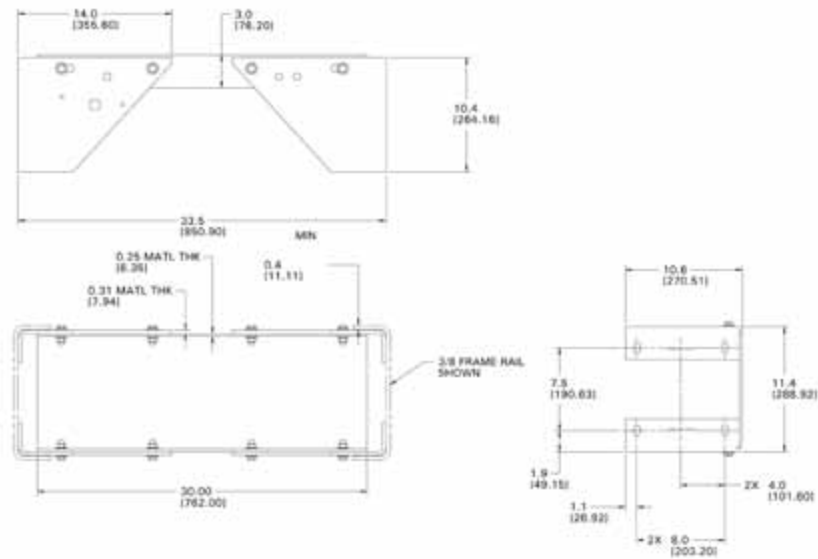

0001616 OPTIONAL
AF CROSSMEMBER

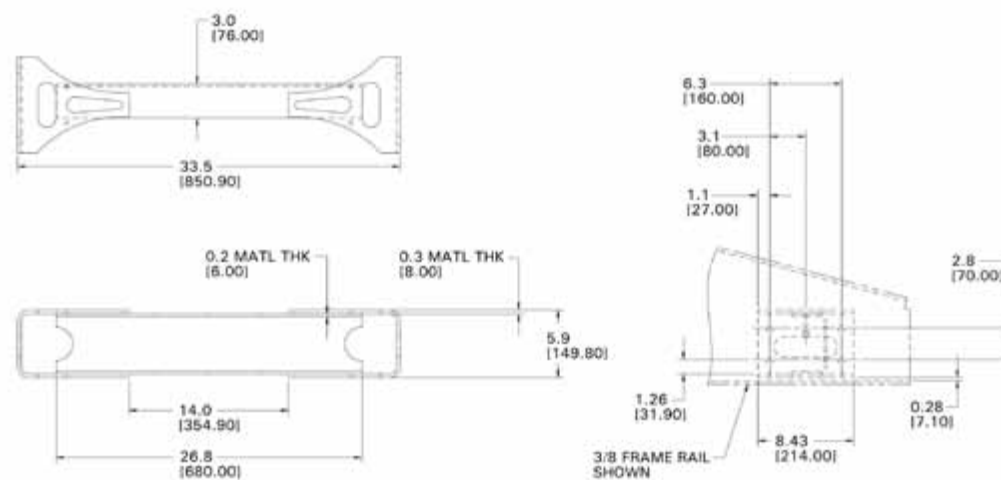

FRAMES

CROSSMEMBER LOCATIONS — 4X4 SUSPENSION

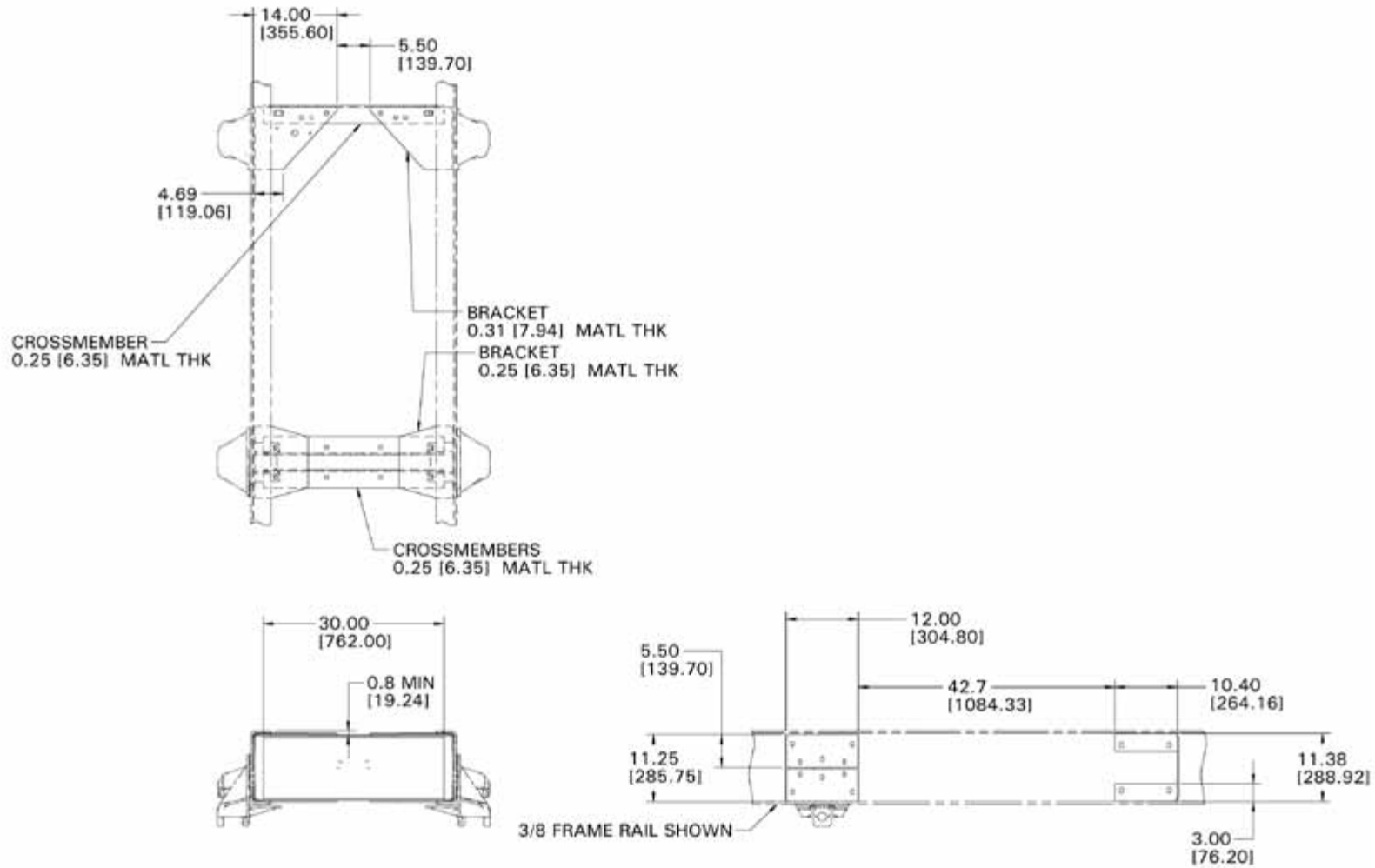

NOTE: Left frame rail and brackets omitted for clarity.

[↶ return to table of contents](#)

FRAMES

CROSSMEMBER LOCATIONS — 660L 4X4 W/ TC142, TC143

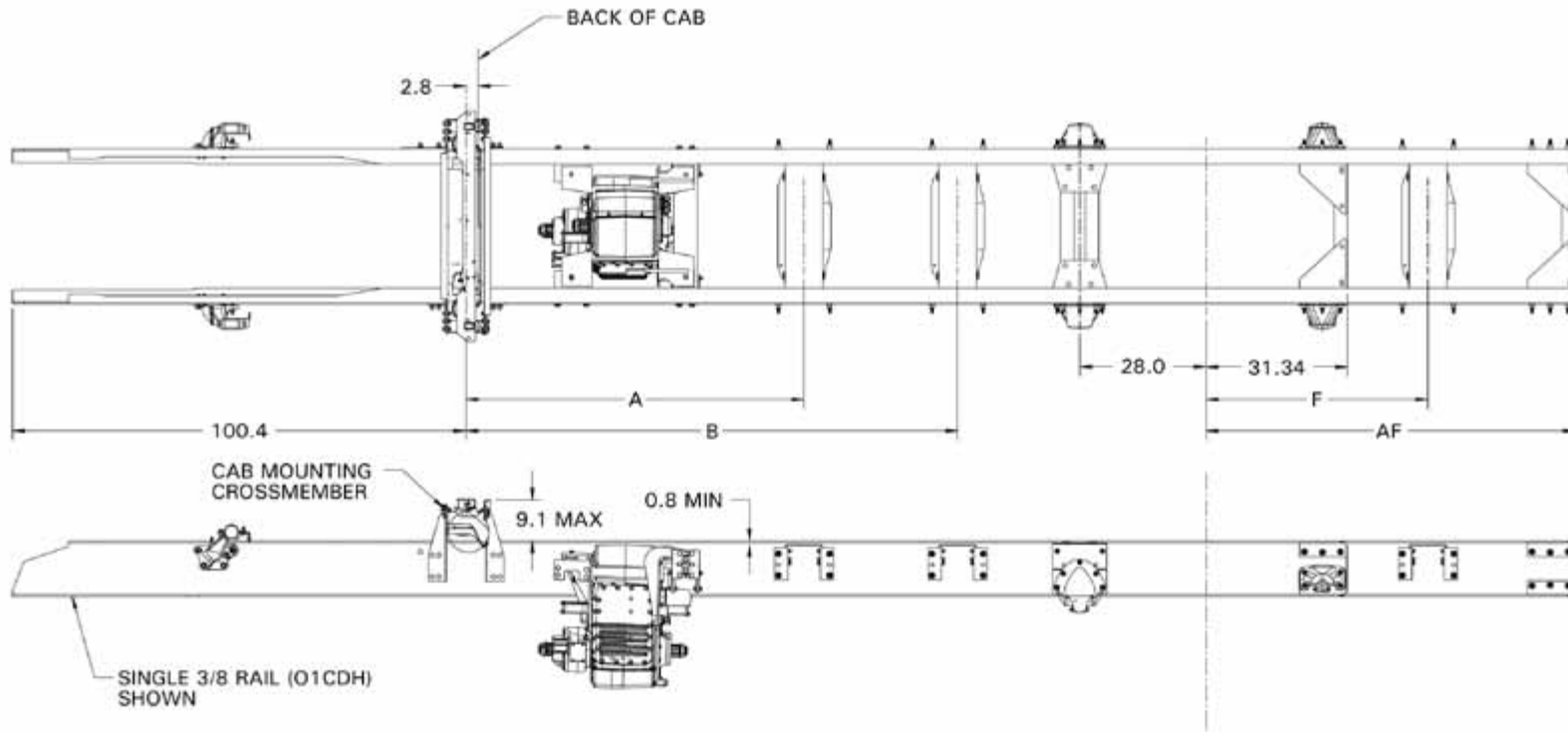

| WHEELBASE | A | B | AF | F | AF | F |
|-----------|------|-----|-----------|------|-----------|----|
| | | | N/0001652 | | W/0001652 | |
| 161-191 | – | – | 37-85 | – | 43-91 | – |
| 193-228 | 74.9 | – | 87-126 | 68.3 | 93-126 | 61 |
| 230-262 | 74.9 | 109 | – | – | – | – |

NOTE: Left frame rail and brackets omitted for clarity. All dimensions are shown in inches.

[↶ return to table of contents](#)

FRAMES

CROSSMEMBER LOCATIONS — 660L 4X4 W/ TC170, TC270

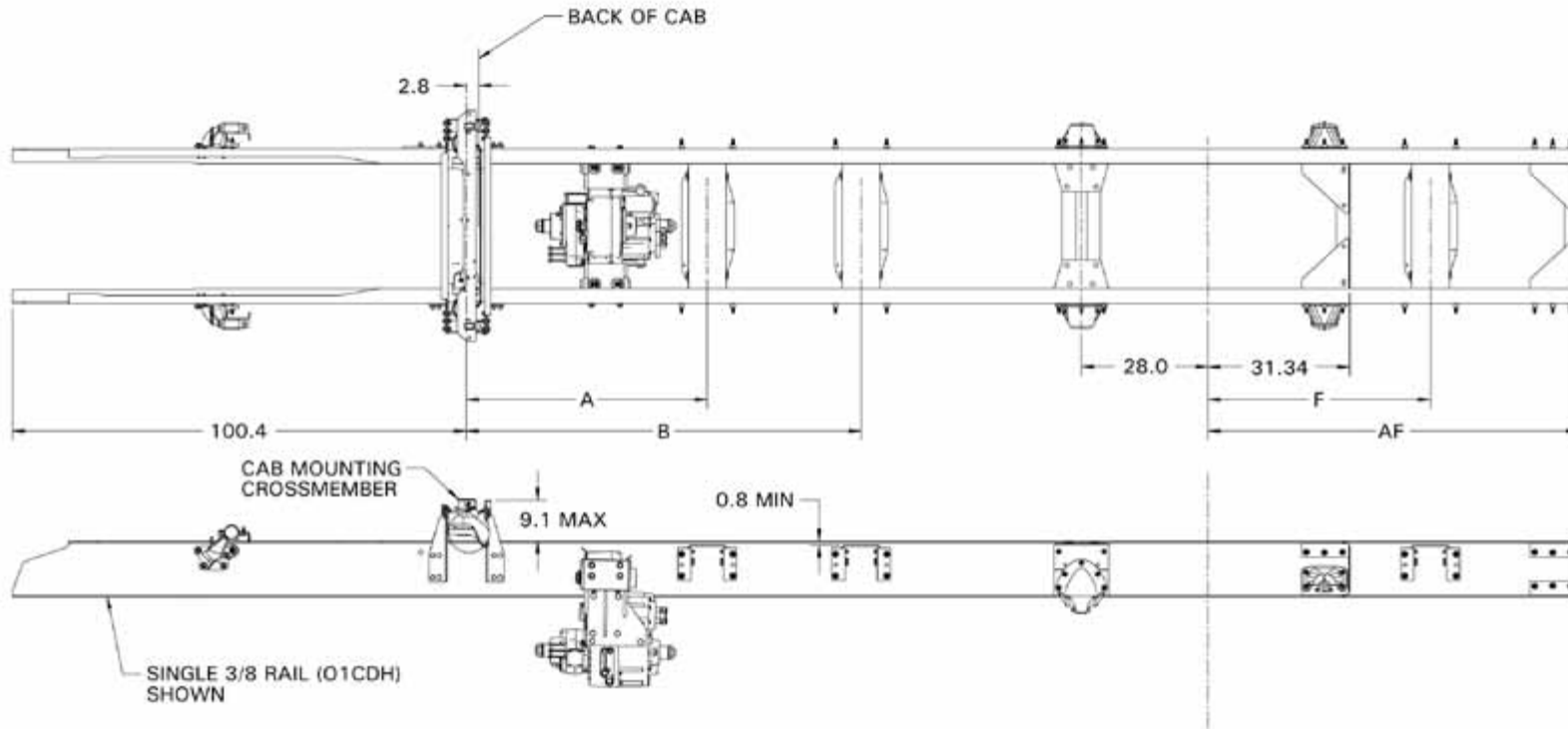

| WHEELBASE | A | B | AF | F | AF | F |
|-----------|-----------|------|--------|-----------|--------|----|
| | N/0001652 | | | W/0001652 | | |
| 181-203 | 52.3 | — | 37-85 | — | 43-91 | — |
| 205-238 | 52.3 | 86.3 | 87-126 | 68.3 | 93-126 | 61 |
| 240-262 | 52.3 | 109 | — | — | — | — |

NOTE: Left frame rail and brackets omitted for clarity. All dimensions are shown in inches.

[↶ return to table of contents](#)

FRAMES

CROSSMEMBER LOCATIONS — 660L/6X6 W/ TC142, TC143

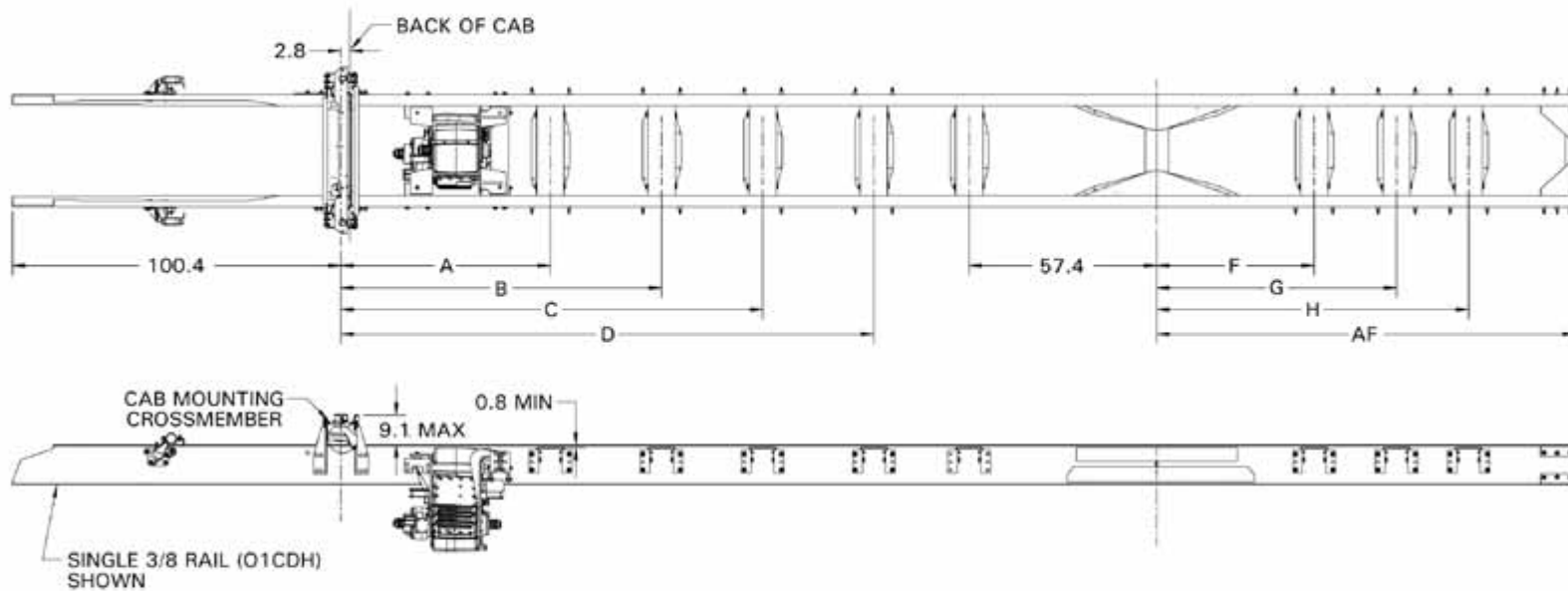

NOTE: Left frame rail and brackets omitted for clarity.

[↶ return to table of contents](#)

FRAMES

CROSSMEMBER LOCATIONS — 660L/6X6 W/ TC142, TC143

| W/72" AXLE SPACING | | | | | | | |
|--------------------|------|------|-------|-----------|------|-------|-------|
| N/0001652 | | | | W/0001652 | | | |
| AF | F | G | H | AF | F | G | H |
| 69-108 | 56.5 | – | – | 61-83 | – | – | – |
| 110-152 | 56.5 | 91.9 | – | 85-110 | 58.4 | – | – |
| 154-181 | 56.5 | 91.9 | 134.3 | 112-138 | 58.4 | 82.6 | – |
| – | – | – | – | 140-165 | 58.4 | 107.3 | – |
| – | – | – | – | 167-181 | 58.4 | 96.3 | 137.4 |

| W/56/60" AXLE SPACING | | | | | | | |
|-----------------------|------|------|-------|-----------|------|-------|-------|
| N/0001652 | | | | W/0001652 | | | |
| AF | F | G | H | AF | F | G | H |
| 65-108 | 52.5 | – | – | 57-73 | – | – | – |
| 110-152 | 56.5 | 91.9 | – | 75-110 | 52.5 | – | – |
| 153-181 | 56.5 | 91.9 | 134.3 | 112-138 | 58.4 | 82.6 | – |
| – | – | – | – | 140-165 | 58.4 | 107.3 | – |
| – | – | – | – | 167-181 | 58.4 | 96.3 | 137.4 |

| W/54" AXLE SPACING | | | | | | | |
|--------------------|------|------|-------|-----------|------|-------|-------|
| N/0001652 | | | | W/0001652 | | | |
| AF | F | G | H | AF | F | G | H |
| 61-108 | 48.6 | – | – | 53-73 | – | – | – |
| 110-152 | 56.5 | 91.9 | – | 75-110 | 52.5 | – | – |
| 154-181 | 56.5 | 91.9 | 134.3 | 112-138 | 58.4 | 82.6 | – |
| – | – | – | – | 140-165 | 58.4 | 107.3 | – |
| – | – | – | – | 167-181 | 58.4 | 96.3 | 137.4 |

| WHEELBASE | A | B | C | D |
|-----------|----|-------|-------|-------|
| 185-221 | – | – | – | – |
| 222-256 | 75 | – | – | – |
| 258-291 | 75 | 109 | – | – |
| 293-313 | 75 | 131.6 | – | – |
| 315-346 | 75 | 120.3 | 170.8 | – |
| 348-382 | 75 | 131.6 | 170.8 | 199.7 |
| 384-394 | 75 | 131.6 | 188.3 | 233.7 |

NOTE: All dimensions are shown in inches.

↶ return to table of contents

FRAMES

CROSSMEMBER LOCATIONS — 660L/6X6 W/ TC170, TC270

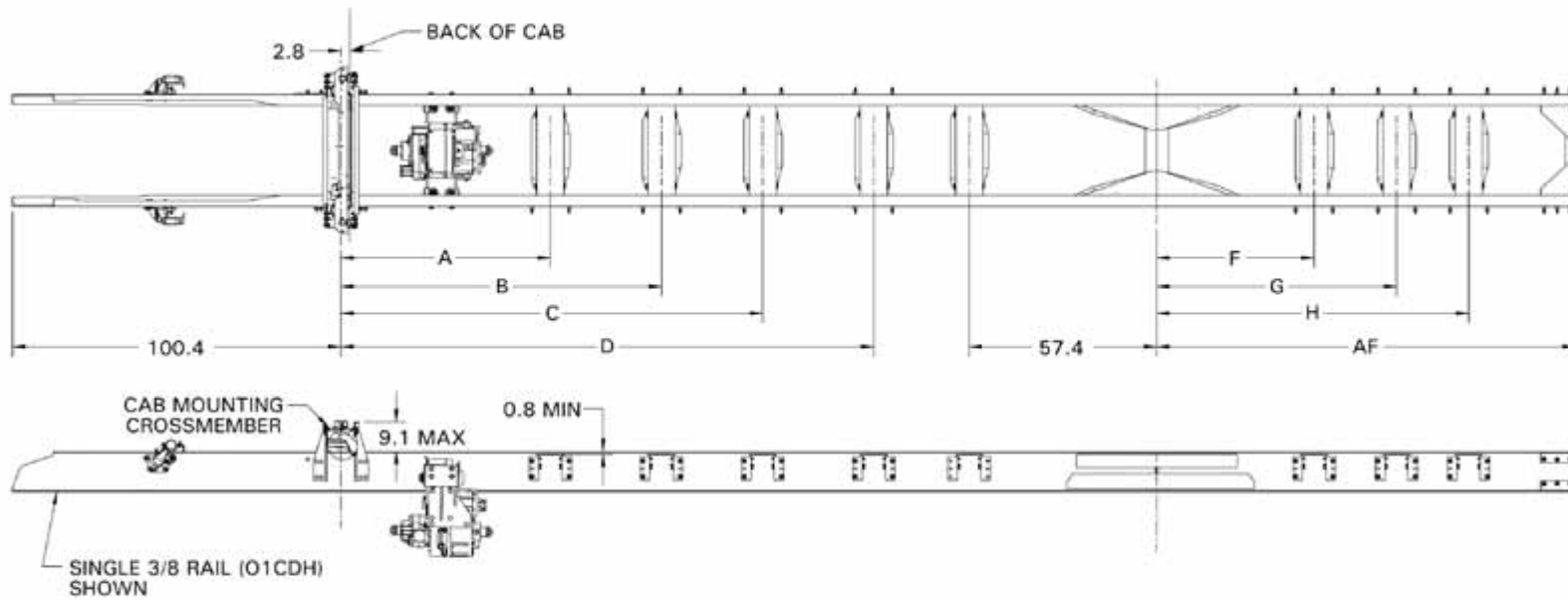

NOTE: Left frame rail and brackets omitted for clarity.

[↶ return to table of contents](#)

FRAMES

CROSSMEMBER LOCATIONS — 660L/6X6 W/ TC170, TC270

| W/72" AXLE SPACING | | | | | | | |
|--------------------|------|------|-------|-----------|------|-------|-------|
| N/0001652 | | | | W/0001652 | | | |
| AF | F | G | H | AF | F | G | H |
| 69-108 | 56.5 | – | – | 61-83 | – | – | – |
| 110-152 | 56.5 | 91.9 | – | 85-110 | 58.4 | – | – |
| 154-181 | 56.5 | 91.9 | 134.3 | 112-138 | 58.4 | 82.6 | – |
| – | – | – | – | 140-165 | 58.4 | 107.3 | – |
| – | – | – | – | 167-181 | 58.4 | 96.3 | 137.4 |

| W/56/60" AXLE SPACING | | | | | | | |
|-----------------------|------|------|-------|-----------|------|-------|-------|
| N/0001652 | | | | W/0001652 | | | |
| AF | F | G | H | AF | F | G | H |
| 65-108 | 52.5 | – | – | 57-73 | – | – | – |
| 110-152 | 56.5 | 91.9 | – | 75-110 | 52.5 | – | – |
| 153-181 | 56.5 | 91.9 | 134.3 | 112-138 | 58.4 | 82.6 | – |
| – | – | – | – | 140-165 | 58.4 | 107.3 | – |
| – | – | – | – | 167-181 | 58.4 | 96.3 | 137.4 |

| W/54" AXLE SPACING | | | | | | | |
|--------------------|------|------|-------|-----------|------|-------|-------|
| N/0001652 | | | | W/0001652 | | | |
| AF | F | G | H | AF | F | G | H |
| 61-108 | 48.6 | – | – | 53-73 | – | – | – |
| 110-152 | 56.5 | 91.9 | – | 75-110 | 52.5 | – | – |
| 154-181 | 56.5 | 91.9 | 134.3 | 112-138 | 58.4 | 82.6 | – |
| – | – | – | – | 140-165 | 58.4 | 107.3 | – |
| – | – | – | – | 167-181 | 58.4 | 96.3 | 137.4 |

| WHEELBASE | A | B | C | D |
|-----------|------|------|-------|-------|
| 167-232 | 52.3 | – | – | – |
| 234-268 | 52.3 | 86.3 | – | – |
| 270-291 | 52.3 | 109 | – | – |
| 293-325 | 52.3 | 97.6 | 143 | – |
| 327-346 | 52.3 | 109 | 165.6 | – |
| 347-382 | 52.3 | 109 | 154.3 | 199.7 |
| 384-492 | 52.3 | 109 | 165.6 | 222.3 |

NOTE: All dimensions are shown in inches.

↪ return to table of contents

FRAMES

CROSSMEMBER LOCATIONS — 8X6 SUSPENSION

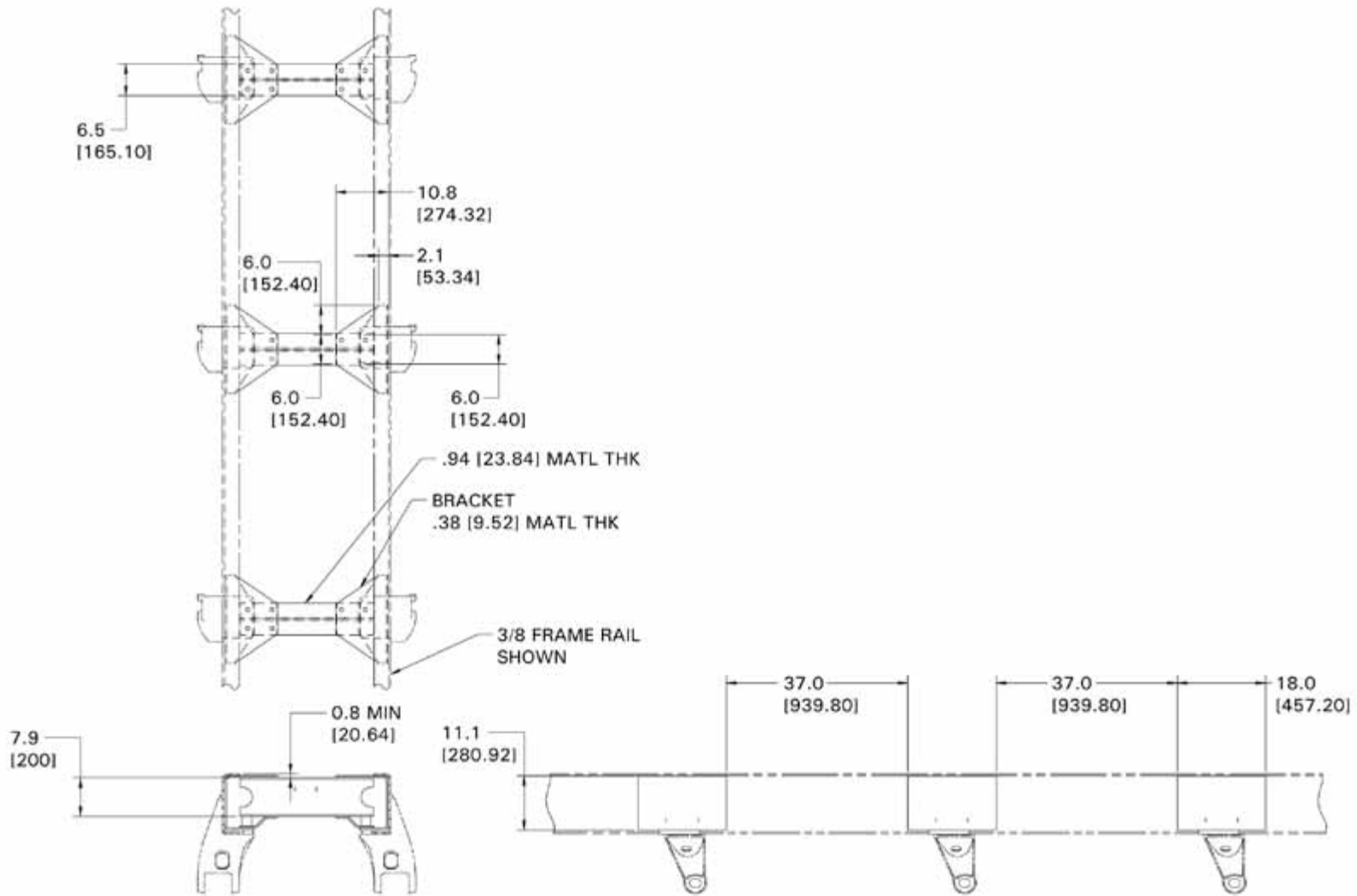

NOTE: Left frame rail and brackets omitted for clarity.

[↶ return to table of contents](#)

FRAMES

CROSSMEMBER LOCATIONS — 660S/660L / 8X6 W/NEWAY SUSPENSION

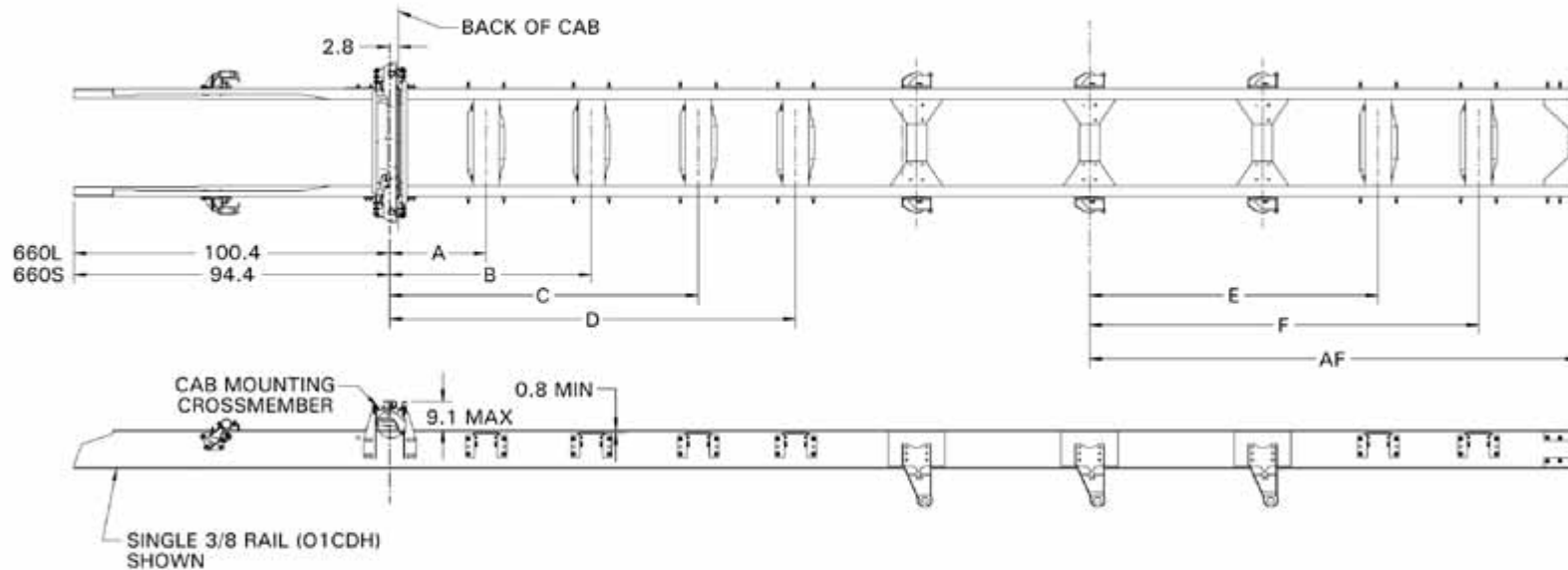

NOTE: Left frame rail and brackets omitted for clarity.

[↶ return to table of contents](#)

FRAMES

CROSSMEMBER LOCATIONS — 660S/660L / 8X6 W/NEWAY SUSPENSION

| 600S WHEELBASE | 600L WHEELBASE | A | B | C | D |
|----------------|----------------|------|------|-------|-------|
| 175-201 | 181-207 | – | – | – | – |
| 203-230 | 209-236 | 29.6 | – | – | – |
| 232-254 | 238-260 | 52.3 | – | – | – |
| 256-287 | 262-293 | 40.9 | 86.3 | – | – |
| 289-311 | 295-317 | 52.3 | 109 | – | – |
| 313-344 | 319-350 | 52.3 | 97.6 | 143 | – |
| 346-366 | 352-372 | 52.3 | 109 | 165.6 | – |
| 368-394 | 374-394 | 52.3 | 109 | 154.3 | 199.7 |

| WHEELBASE | | | | | |
|-----------|----|-------|-----------|----|-----|
| N/0001652 | | | W/0001652 | | |
| AF | E | F | AF | E | F |
| 98-138 | 86 | – | 91-114 | – | – |
| 140-181 | 86 | 121.4 | 116-144 | 86 | – |
| – | – | – | 146-181 | 86 | 117 |

NOTE: All dimensions are shown in inches.

FRAMES

CROSSMEMBER LOCATIONS — 660S/660L / 6X4 W/55" HENDRICKSON HAS SUSPENSION

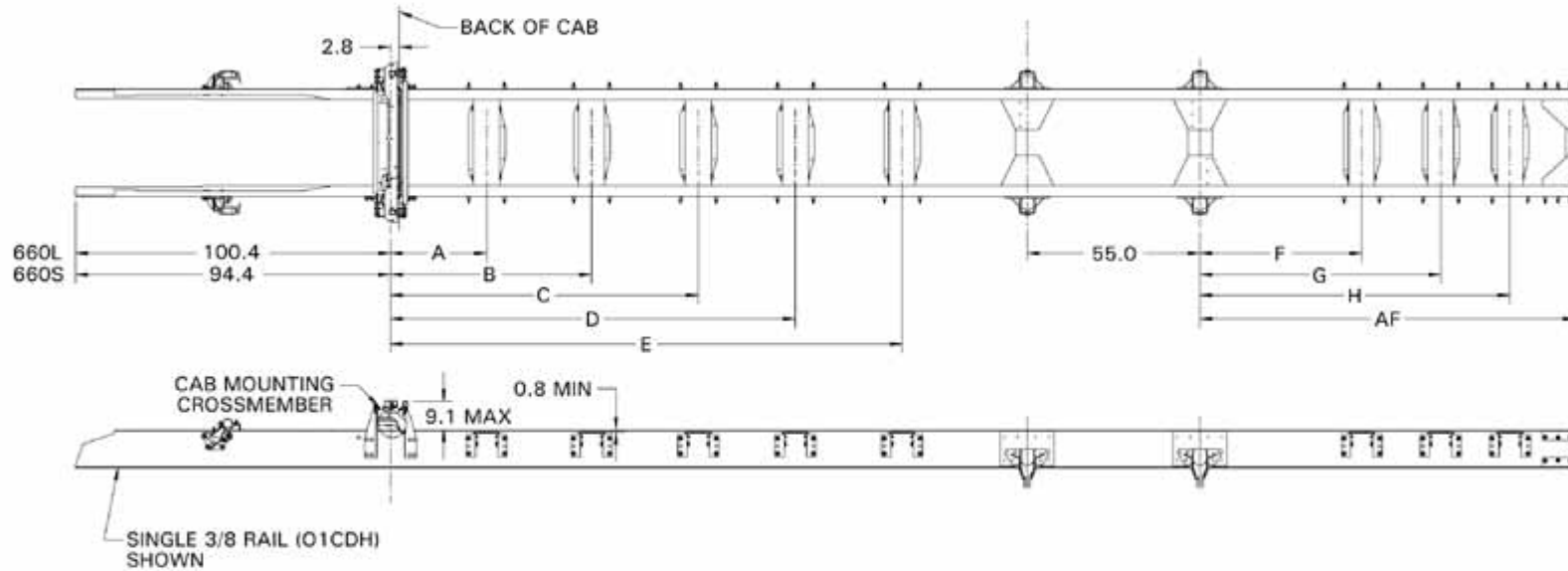

NOTE: All dimensions shown are in inches.

[↶ return to table of contents](#)

FRAMES

CROSSMEMBER LOCATIONS — 660S/660L / 6X4 W/55" HENDRICKSON HAS SUSPENSION

| 600S WHEELBASE | 600L WHEELBASE | A | B | C | D | E |
|----------------|----------------|------|------|-------|-------|-------|
| 138-165 | 144-171 | – | – | – | – | – |
| 167-195 | 173-201 | 29.6 | – | – | – | – |
| 197-219 | 203-224 | 52.3 | – | – | – | – |
| 221-252 | 226-258 | 40.9 | 86.3 | – | – | – |
| 254-276 | 260-282 | 52.3 | 109 | – | – | – |
| 278-309 | 283-315 | 52.3 | 97.6 | 143 | – | – |
| 311-331 | 317-337 | 52.3 | 109 | 165.6 | – | – |
| 333-366 | 339-372 | 52.3 | 109 | 154.3 | 199.7 | – |
| 368-388 | 374-394 | 52.3 | 109 | 165.6 | 222.3 | – |
| 390-394 | – | 52.3 | 109 | 165.6 | 211 | 256.4 |

| W/55" AXLE SPACING | | | | | | | |
|--------------------|------|-------|-------|-----------|------|-------|---|
| N/0001652 | | | | W/0001652 | | | |
| AF | F | G | H | AF | F | G | H |
| 71-118 | 58.4 | – | – | 63-87 | – | – | – |
| 120-161 | 58.4 | 101.8 | – | 89-120 | 59 | – | – |
| 163-181 | 58.4 | 101.8 | 145.1 | 122-154 | 61.4 | 92.4 | – |
| – | – | – | – | 156-181 | 61.4 | 119.4 | – |

NOTE: All dimensions are shown in inches.

FRAMES

CROSSMEMBER LOCATIONS — 660S/660L / 55" HENDRICKSON PRIMAAX SUSPENSION

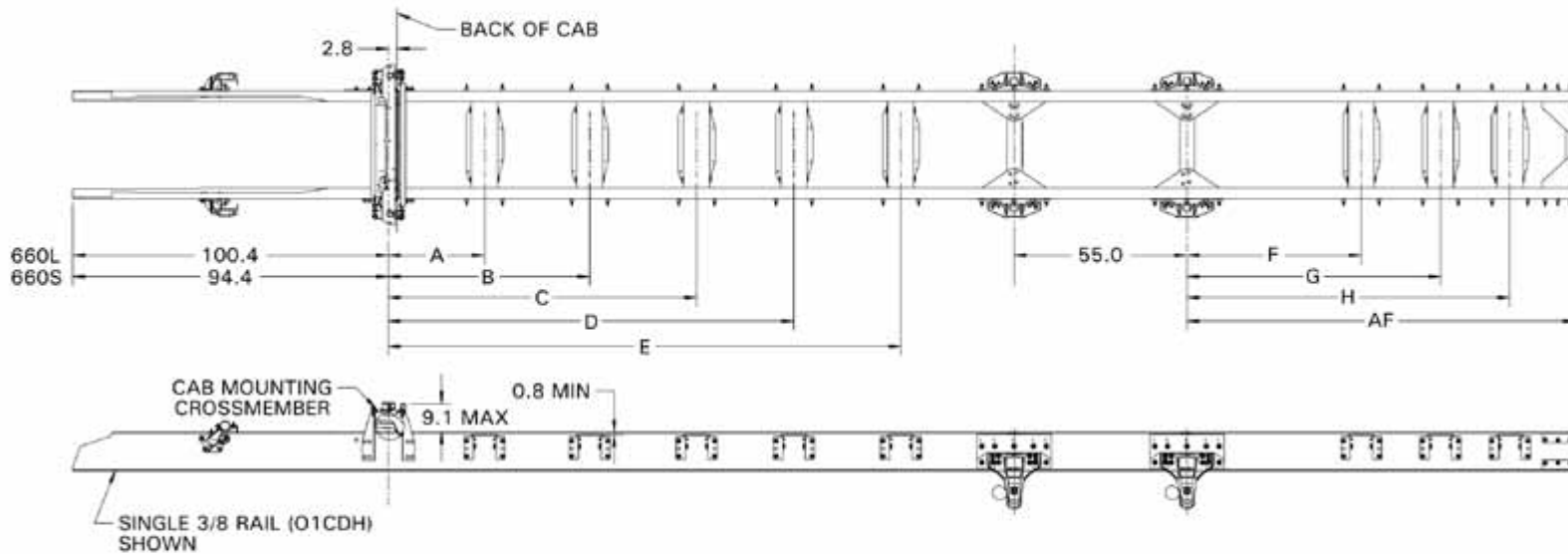

NOTE: All dimensions shown are in inches.

[↶ return to table of contents](#)

FRAMES

CROSSMEMBER LOCATIONS — 660S/660L / 55" HENDRICKSON PRIMAAAX SUSPENSION

| 600S WHEELBASE | 600L WHEELBASE | A | B | C | D | E |
|----------------|----------------|------|------|-------|-------|-------|
| 146-169 | 152-175 | – | – | – | – | – |
| 171-199 | 177-205 | 29.6 | – | – | – | – |
| 201-222 | 207-228 | 52.3 | – | – | – | – |
| 224-256 | 230-262 | 40.9 | 86.3 | – | – | – |
| 258-280 | 264-285 | 52.3 | 109 | – | – | – |
| 282-313 | 287-319 | 52.3 | 97.6 | 143 | – | – |
| 315-335 | 321-341 | 52.3 | 109 | 157.8 | – | – |
| 337-370 | 343-376 | 52.3 | 109 | 165.6 | 199.7 | – |
| 372-292 | 378-394 | 52.3 | 109 | 157.8 | 222.3 | – |
| 394 | – | 52.3 | 109 | 157.8 | 211 | 256.4 |

| W/55" AXLE SPACING | | | | | | | |
|--------------------|------|-------|-------|-----------|------|-------|---|
| N/0001652 | | | | W/0001652 | | | |
| AF | F | G | H | AF | F | G | H |
| 71-118 | 58.4 | – | – | 63-87 | – | – | – |
| 120-161 | 58.4 | 101.8 | – | 89-120 | 59 | – | – |
| 163-181 | 58.4 | 101.8 | 145.1 | 122-154 | 61.4 | 92.4 | – |
| – | – | – | – | 156-181 | 61.4 | 119.4 | – |

NOTE: All dimensions shown are in inches.

FRAMES

CROSSMEMBER LOCATIONS — 660S/660L / 6X4 W/60" HENDRICKSON HAS SUSPENSION

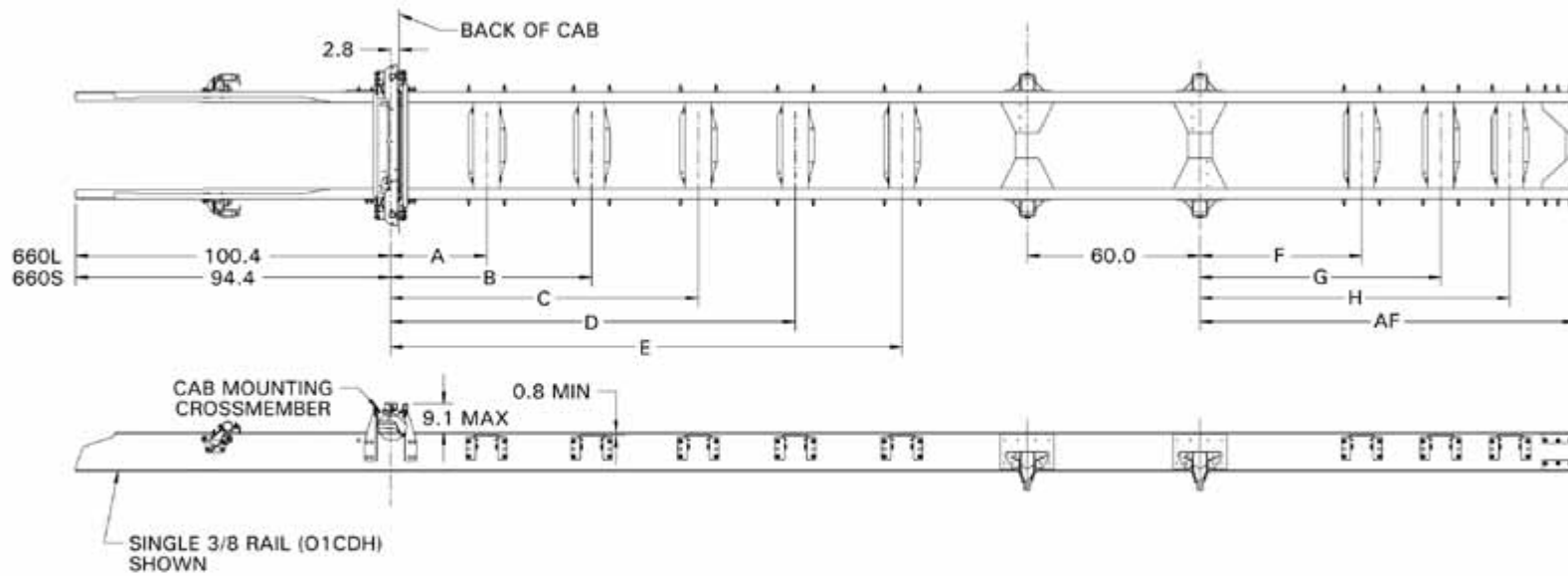

NOTE: All dimensions shown are in inches.

[↶ return to table of contents](#)

FRAMES

CROSSMEMBER LOCATIONS — 660S/660L / 6X4 W/60" HENDRICKSON HAS SUSPENSION

| 600S WHEELBASE | 600L WHEELBASE | A | B | C | D | E |
|----------------|----------------|------|------|-------|-------|-------|
| 142-169 | 148-175 | – | – | – | – | – |
| 171-199 | 177-205 | 29.6 | – | – | – | – |
| 201-221 | 207-226 | 52.3 | – | – | – | – |
| 222-254 | 228-260 | 41 | 86.3 | – | – | – |
| 256-278 | 262-283 | 52.3 | 109 | – | – | – |
| 280-311 | 285-317 | 52.3 | 97.6 | 143 | – | – |
| 313-335 | 319-341 | 52.3 | 109 | 165.6 | – | – |
| 337-368 | 343-374 | 52.3 | 109 | 154.3 | 199.7 | – |
| 370-390 | 376-394 | 52.3 | 109 | 165.6 | 222.3 | – |
| 392-394 | – | 52.3 | 109 | 165.6 | 211 | 256.4 |

| W/60" AXLE SPACING | | | | | | | |
|--------------------|------|-------|-----|-----------|------|-------|---|
| N/0001652 | | | | W/0001652 | | | |
| AF | F | G | H | AF | F | G | H |
| 73-120 | 60.4 | – | – | 65-89 | – | – | – |
| 122-163 | 60.4 | 103.7 | – | 91-120 | 61.4 | – | – |
| 163-181 | 60.4 | 103.7 | 147 | 122-154 | 61.4 | 92.4 | – |
| – | – | – | – | 156-181 | 61.4 | 119.4 | – |

NOTE: All dimensions shown are in inches.

FRAMES

CROSSMEMBER LOCATIONS — 660S/660L / 60" HENDRICKSON PRIMAAAX SUSPENSION

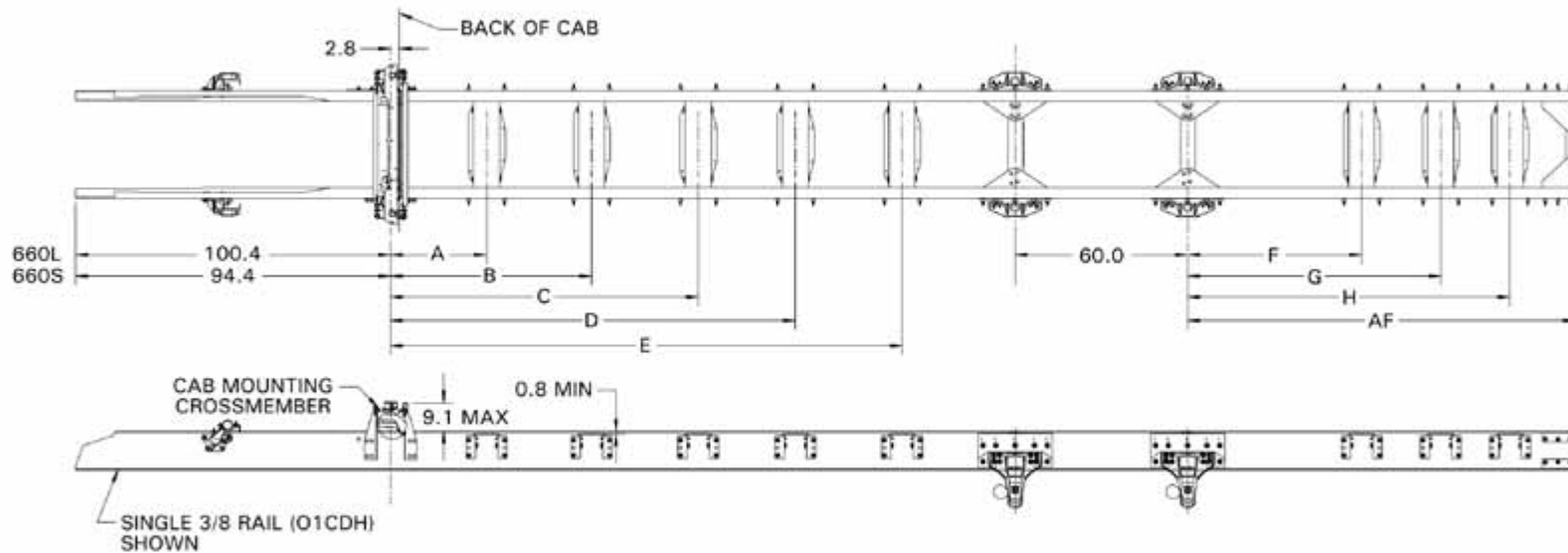

NOTE: All dimensions shown are in inches.

[↶ return to table of contents](#)

FRAMES

CROSSMEMBER LOCATIONS — 660S/660L / 60" HENDRICKSON PRIMAAAX SUSPENSION

| 600S WHEELBASE | 600L WHEELBASE | A | B | C | D | E |
|----------------|----------------|------|------|-------|-------|---|
| 148-171 | 154-177 | – | – | – | – | – |
| 173-203 | 179-209 | 29.6 | – | – | – | – |
| 205-224 | 211-230 | 52.3 | – | – | – | – |
| 226-258 | 232-264 | 41 | 86.3 | – | – | – |
| 260-282 | 266-287 | 52.3 | 109 | – | – | – |
| 283-315 | 289-321 | 52.3 | 97.6 | 143 | – | – |
| 317-339 | 323-344 | 52.3 | 109 | 165.6 | – | – |
| 341-372 | 346-378 | 52.3 | 109 | 154.3 | 199.7 | – |
| 374-394 | 380-394 | 52.3 | 109 | 165.6 | 222.3 | – |

| W/55" AXLE SPACING | | | | | | | |
|--------------------|------|-------|-------|-----------|------|-------|---|
| N/0001652 | | | | W/0001652 | | | |
| AF | F | G | H | AF | F | G | H |
| 71-118 | 58.4 | – | – | 63-87 | – | – | – |
| 120-161 | 58.4 | 101.8 | – | 89-120 | 59 | – | – |
| 163-181 | 58.4 | 101.8 | 145.1 | 122-154 | 61.4 | 92.4 | – |
| – | – | – | – | 156-181 | 61.4 | 119.4 | – |

NOTE: All dimensions shown are in inches.

FRAMES

CROSSMEMBER LOCATIONS — 660S/660L / 72" HENDRICKSON PRIMAAAX SUSPENSION

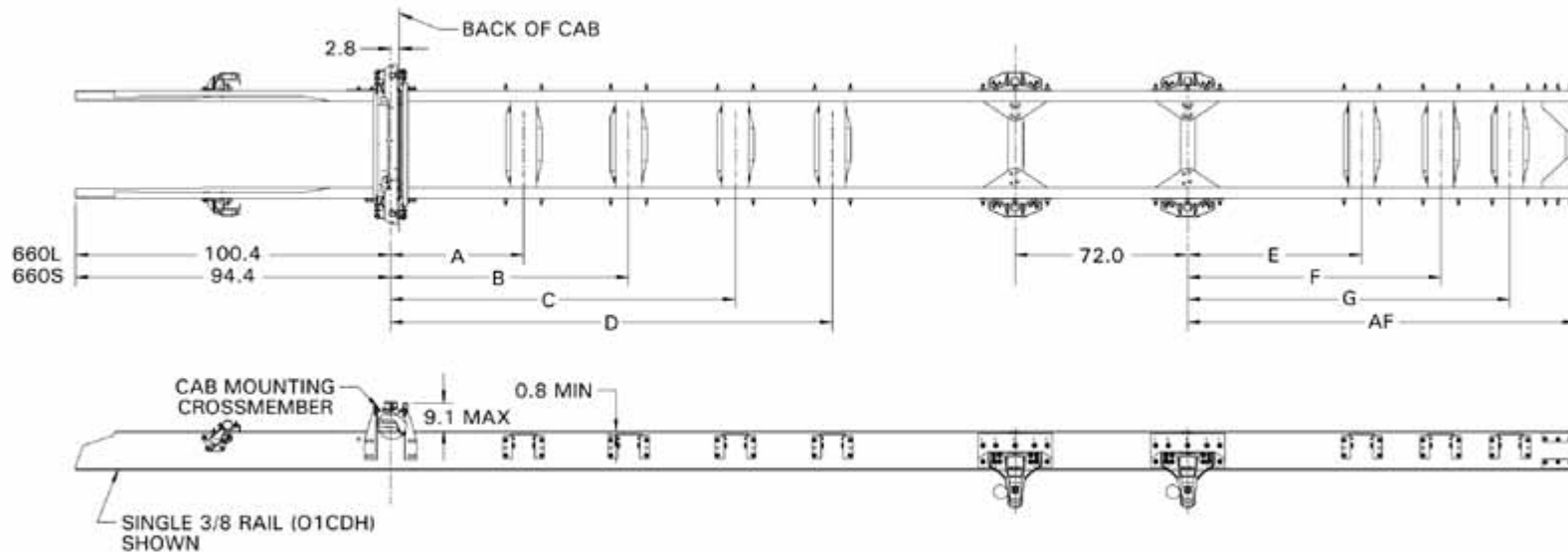

NOTE: Left frame rail and brackets omitted for clarity.

[↶ return to table of contents](#)

FRAMES

CROSSMEMBER LOCATIONS — 660S/660L / 72" HENDRICKSON PRIMAAAX SUSPENSION

| 600S WHEELBASE | 600L WHEELBASE | A | B | C | D |
|----------------|----------------|------|------|-------|-------|
| 154-179 | 160-185 | – | – | – | – |
| 181-209 | 187-215 | 29.6 | – | – | – |
| 211-230 | 217-236 | 52.3 | – | – | – |
| 232-264 | 238-270 | 40.9 | 86.3 | – | – |
| 266-287 | 272-293 | 52.3 | 109 | – | – |
| 289-321 | 295-327 | 52.3 | 97.6 | 143 | – |
| 323-344 | 329-350 | 52.3 | 109 | 165.6 | – |
| 346-378 | 352-384 | 52.3 | 109 | 154.3 | 199.7 |
| 380-394 | 386-394 | 52.3 | 109 | 165.6 | 222.3 |

| W/72" AXLE SPACING | | | | | | |
|--------------------|------|-------|-----|-----------|------|-------|
| N/0001652 | | | | W/0001652 | | |
| AF | E | F | G | AF | E | F |
| 73-120 | 60.4 | – | – | 65-89 | – | – |
| 122-163 | 60.4 | 103.7 | – | 91-120 | 61.4 | – |
| 165-181 | 60.4 | 103.7 | 147 | 122-154 | 61.4 | 92.4 |
| – | – | – | 147 | 156-181 | 61.4 | 119.4 |

NOTE: All dimensions shown are in inches.

FRAMES

CROSSMEMBER LOCATIONS — 660S & 660L 6X4, 6X6 WALKING BEAMS SUSPENSION

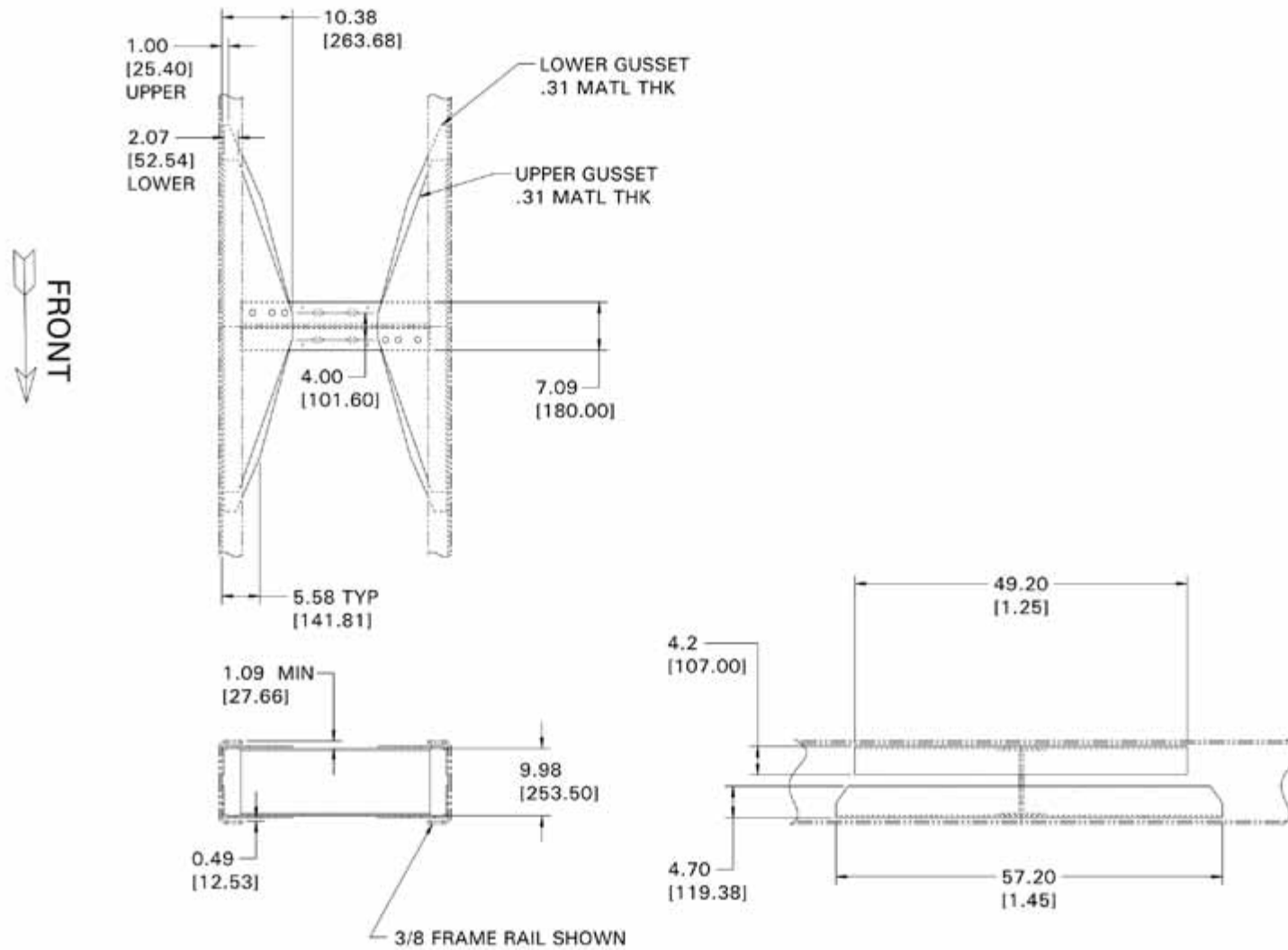

NOTE: Left Outer Rail removed for clarity.

[↶ return to table of contents](#)

FRAMES

CROSSMEMBER LOCATIONS — 660S & 660L 6X4 HAS SUSPENSION CROSSMEMBERS

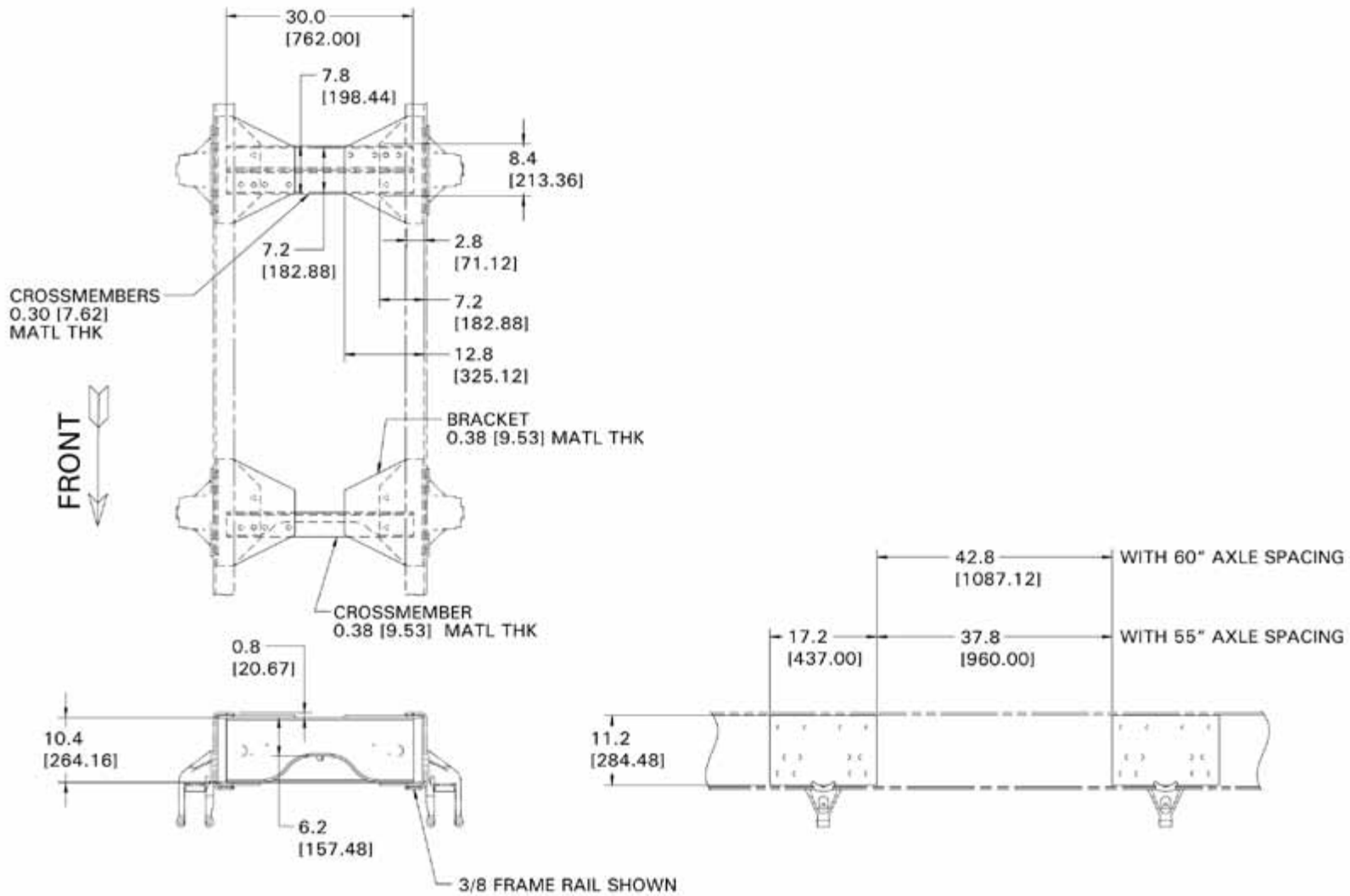

NOTE: Left side rail and brackets omitted for clarity.

[↶ return to table of contents](#)

FRAMES

CROSSMEMBER LOCATIONS — 660S & 660L 6X4 PRIMAAX SUSPENSION CROSSMEMBERS

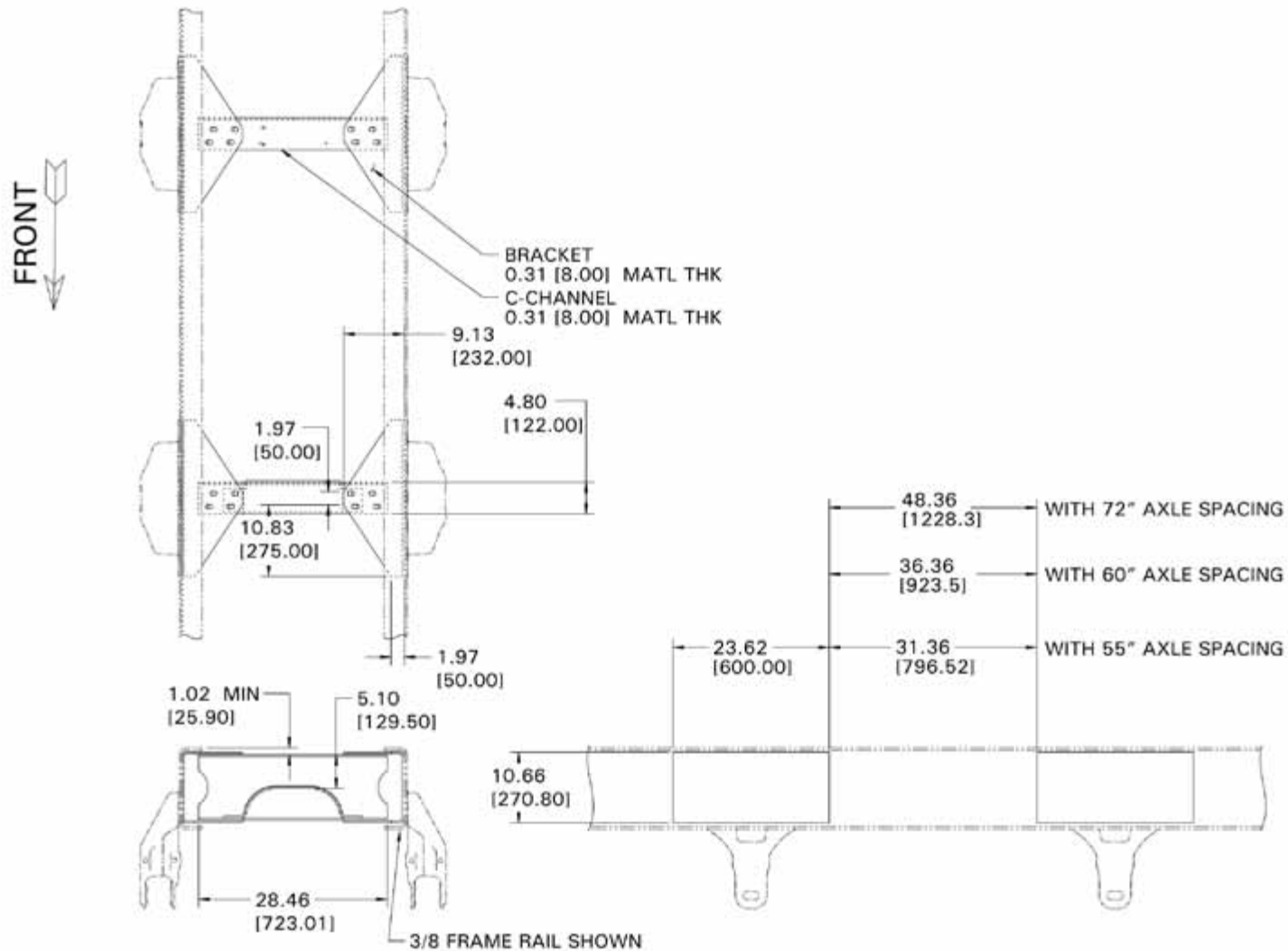

NOTE: Left outer rail and hanger brackets removed for clarity.

↪ return to table of contents

FRAMES

CROSSMEMBER LOCATIONS — 660S & 660L / 6X4 / W/ R, RT, RS & HMX HENDRICKSON SUSPENSION OR CHALMERS SUSPENSION

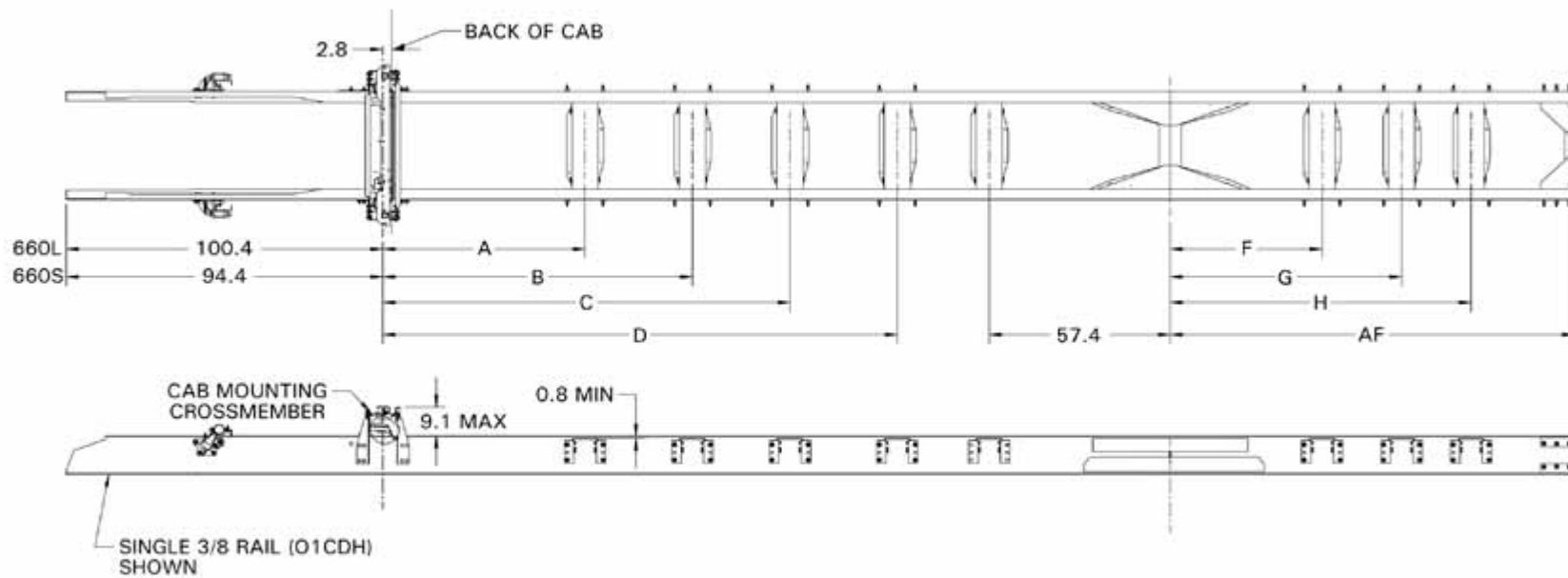

NOTE: All dimensions are shown in inches.

[↶ return to table of contents](#)

FRAMES

CROSSMEMBER LOCATIONS — 6X4 / W/ R, RT, RS & HMX HENDRICKSON OR CHALMERS

| W/72" AXLE SPACING | | | | | | | |
|--------------------|------|------|-------|-----------|------|-------|-------|
| N/0001652 | | | | W/0001652 | | | |
| AF | F | G | H | AF | F | G | H |
| 69-108 | 56.5 | – | – | 61-83 | – | – | – |
| 110-152 | 56.5 | 91.9 | – | 85-110 | 58.4 | – | – |
| 154-181 | 56.5 | 91.9 | 134.3 | 112-138 | 58.4 | 82.6 | – |
| – | – | – | – | 140-165 | 58.4 | 107.3 | – |
| – | – | – | – | 167-181 | 58.4 | 96.3 | 137.4 |

| W/56/60" AXLE SPACING | | | | | | | |
|-----------------------|------|------|-------|-----------|------|-------|-------|
| N/0001652 | | | | W/0001652 | | | |
| AF | F | G | H | AF | F | G | H |
| 65-108 | 52.5 | – | – | 57-73 | – | – | – |
| 110-152 | 56.5 | 91.9 | – | 75-110 | 52.5 | – | – |
| 153-181 | 56.5 | 91.9 | 134.3 | 112-138 | 58.4 | 82.6 | – |
| – | – | – | – | 140-165 | 58.4 | 107.3 | – |
| – | – | – | – | 167-181 | 58.4 | 96.3 | 137.4 |

| W/54" AXLE SPACING | | | | | | | |
|--------------------|------|------|-------|-----------|------|-------|-------|
| N/0001652 | | | | W/0001652 | | | |
| AF | F | G | H | AF | F | G | H |
| 61-108 | 48.6 | – | – | 53-73 | – | – | – |
| 110-152 | 56.5 | 91.9 | – | 75-110 | 52.5 | – | – |
| 154-181 | 56.5 | 91.9 | 134.3 | 112-138 | 58.4 | 82.6 | – |
| – | – | – | – | 140-165 | 58.4 | 107.3 | – |
| – | – | – | – | 167-181 | 58.4 | 96.3 | 137.4 |

| 600S WHEELBASE | 600L WHEELBASE | A | B | C | D |
|----------------|----------------|------|------|-------|-------|
| 146-175 | 152-181 | – | – | – | – |
| 177-205 | 183-211 | 29.6 | – | – | – |
| 207-228 | 213-234 | 52.3 | – | – | – |
| 230-262 | 236-268 | 40.9 | 86.3 | – | – |
| 264-285 | 270-291 | 52.3 | 109 | – | – |
| 287-319 | 293-325 | 52.3 | 97.6 | 143 | – |
| 321-341 | 327-346 | 52.3 | 109 | 165.6 | – |
| 343-376 | 348-382 | 52.3 | 109 | 154.3 | 199.7 |
| 378-394 | 384-394 | 52.3 | 109 | 165.6 | 222.3 |

NOTE: All dimensions are shown in inches.

↶ return to table of contents

FRAMES

FRAME DRILLING GUIDELINES

The drilling of the frame sidemembers presents no unusual difficulty. Standard high speed steel drills of good quality will serve provided they are sharpened properly and are not overheated during sharpening.

HOLE LOCATION GUIDELINES

- 1) Never drill holes into the restricted areas of the frame rails. Refer to diagrams on the following pages.
- 2) Use existing holes when ever possible.
- 3) Maintain a minimum of 0.75" (19.0mm) of material between holes.
- 4) There should be no more than three holes in a vertical line.
- 5) Bolt holes should be no larger than is required for the size of bolt being used, in no instance larger than 0.688" (17.5mm).
- 6) If reinforcements are used, avoid drilling holes closer than 2.0" (50mm) from the ends of the reinforcement.
- 7) Bolt must be periodically checked to insure that the proper torque and clamping force is maintained.
- 8) Never drill holes in the flanges of the frame rails.

| FRAME HEIGHT | |
|-------------------|------------------|
| FEATURE CODE | DIMENSION |
| 0001CDH | 12.25" (311.1mm) |
| 0001DAV & 0001GDL | 12.65" (321.3mm) |
| 0001CDH & 0001GDM | 13.03" (331mm) |

FRAMES

RECOVERY DEVICES

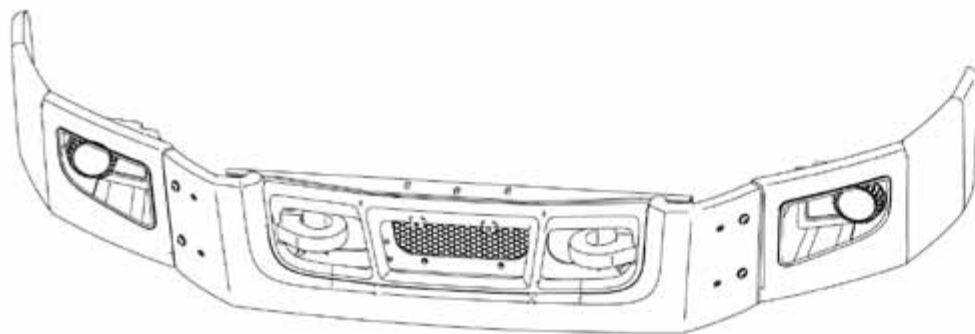

0001570 FRONT TOW HOOKS

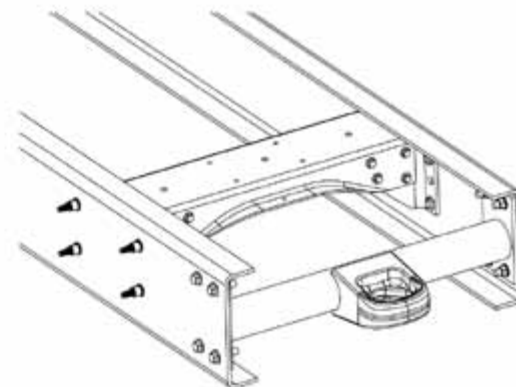

0001UAZ REAR TOW LOOP

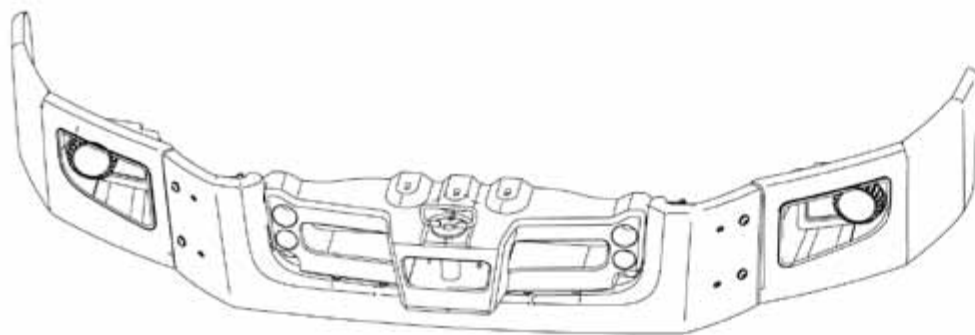

0001VAN FRONT TOW PIN CROSSMEMBER

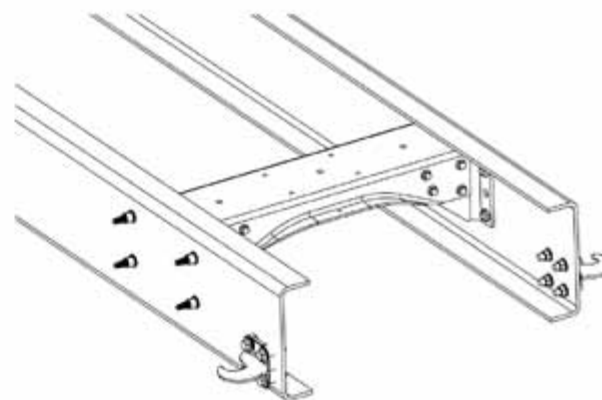

0001572 REAR TOW HOOKS

[↶ return to table of contents](#)

FRONT AXLES

FRONT AXLE TREAD

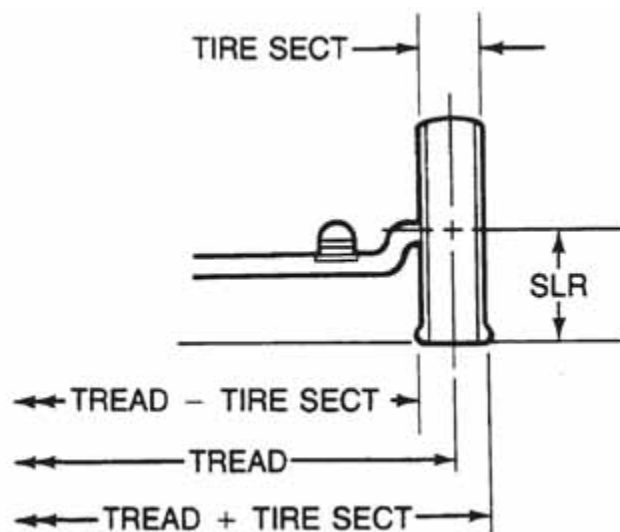

| | |
|---|---|
| TREAD | Distance (width) between vertical centerlines of single tires at opposite ends of axle, or between vertical centerlines of dual spacing (D.S.) at opposite ends of axle. |
| TIRE SECT (TIRE SECTION) | Overall width of new tire at top of tire under maximum load, including 24-hour inflation growth, and including protective side ribs, bars and decorations recommended by tire manufacturer. |
| TREAD + TIRE SECT (TREAD PLUS TIRE SECTION) | Overall width of axle, rim, and tire assembly at top of tires under maximum load recommended by tire manufacturer. |
| TREAD - TIRE SECT (TREAD MINUS TIRE SECTION) | Distance (width) between near sides of tires at opposite ends of axle at top of tire under maximum load recommended by the tire manufacturer. |
| SLR (STATIC LOAD RADIUS) | Distance from ground to centerline of hub when tires are correctly inflated and under maximum load recommended by tire manufacturer. |

The chart shown here lists tread information for various wheel/axle combinations. Tread dimensions are not dependent on tire size. Other dimensions explained here are related to tread and require tire dimensions. Please contact your tire supplier.

FRONT AXLES

FRONT AXLE TREAD

| DISC WHEEL/RIM | | AXLE CODE | | | | | |
|----------------|-----------------------|-----------|-------------------------------|--------------------|--------------------|---------|---------|
| SIZE | MATERIAL | 0002AEU | 0002AEV 0002AEW 0002AGT | 0002ARW 0002ASG | 0002ATB 0002ARY | 0002ASM | 0002ARU |
| 22.5 X 8.25 | Steel | 82.72 | 82.22 | 81.63 | 82.22 | 81.63 | 82.716 |
| | Aluminum | 83.68 | 83.18 | 82.59 | 83.18 | 82.59 | 83.68 |
| 22.5 x 9.00 | Steel (7.0" Offset) | 82.34 | 81.84 | – | 81.84 | – | 82.34 |
| | Steel (5.25" Offset) | 85.59 | 85.09 | 84.5 | 85.09 | 84.5 | 85.59 |
| | Aluminum | 83.05 | 82.55 | – | 82.55 | – | 83.05 |
| 22.5 x 12.25 | Steel (4.625" Offset) | 87.09 | 86.59 | – | 86.59 | – | 87.09 |
| | Steel (6.375" Offset) | 83.59 | 83.09 | – | 83.09 | – | 83.59 |
| | Aluminum | 85.58 | 85.08 | – | 85.08 | – | 85.59 |
| 22.5 x 13.00 | Steel | – | 84.09 | – | 84.09 | – | 84.59 |
| | Aluminum | 84.58 | 84.08 | – | 84.08 | – | 84.6 |
| 24.5 x 8.25 | Steel | 82.72 | 82.22 | 81.63 | 82.22 | 81.63 | 82.72 |
| | Aluminum | 83.78 | 83.28 | 82.69 | 83.28 | 82.69 | 83.78 |

NOTE: Widths calculated with standard wheel ends and standard brake drums. All wheel sizes may not be available with above feature codes.

FRONT SUSPENSIONS

FRONT SPRING BRACKET LOCATION

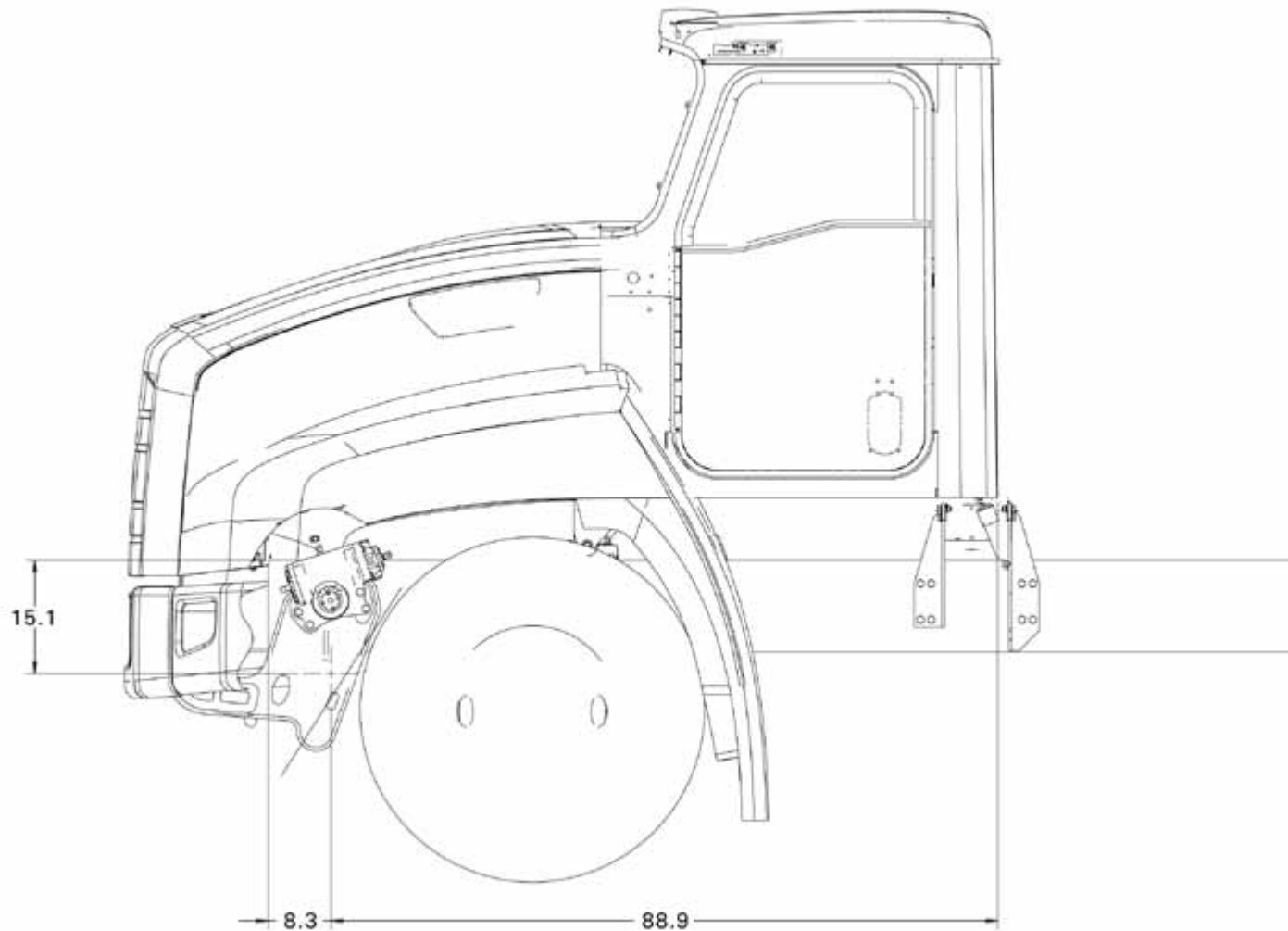

NOTE: All dimensions are with 0001CDH 3/8 frame rail. Bumper and fender partially cut away for clarity.

[↶ return to table of contents](#)

FRONT SUSPENSIONS

FRAME HEIGHT CHART

| MODEL | FRONT SUSPENSION | | | SPINDLE TO BOTTOM OF FRAME* | |
|----------|-------------------------|--------------|----------------|-----------------------------|-------------------|
| | TYPE | FEATURE CODE | CAPACITY (LBS) | UNLOADED - DF (IN.) | LOADED - DF (IN.) |
| | Parabolic | 03AGD | 13,200 | 8.68 | 7.89 |
| | | 03AGA | 20,000 | 9.06 | 7.69 |
| 6x4, 8x6 | Multileaf | 03ACH | 14,000 | 8.3 | 7.2 |
| | | 03ACP | 16,000 | 8.5 | 7.7 |
| | | 03ACR | 18,000 | 8.0 | 6.8 |
| | | 03ACS, 03AGR | 20,000 | 8.3 / 8 | 6.8 / 6.3 |
| | | 03ACT, 03AEP | 23,000 | 8.5 | 6.9 |
| | Multileaf w/ Torque Rod | 03ACU, 03ADR | 20,000 | 7.9 | 6.3 |
| | | 03ACX | 24,000 | 8.8 | 7.2 |
| 4x4, 6x6 | Multileaf | 03ACP | 16,000 | 16.2 | 15.2 |
| | | 03ACR | 18,000 | 16.2 | 15.1 |
| | | 03AEP | 23,000 | 16.1 | 14.4 |
| | Multileaf w/ Torque Rod | 03ACW | 21,000 | 16.3 | 14.7 |
| | | 03ACX | 24,000 | 17.2 | 15.6 |

*Measurements are with a standard tire.

[↶ return to table of contents](#)

REAR AXLES & REAR SUSPENSIONS

REAR AXLE TREAD

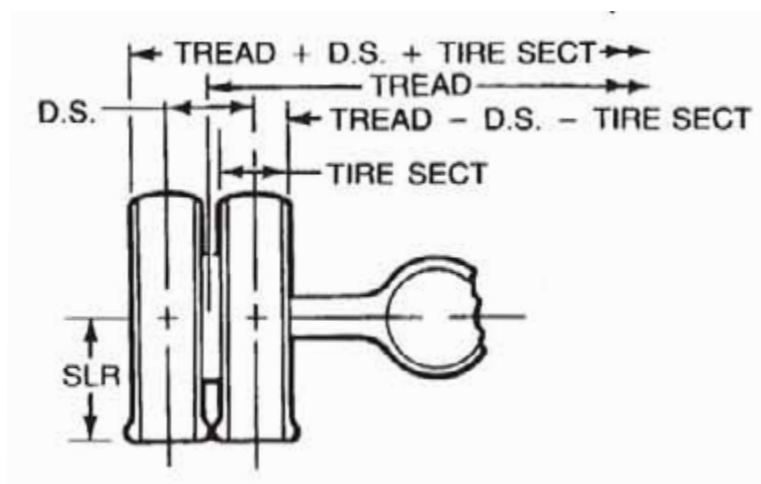

| | |
|--|---|
| TREAD | Distance (width) between vertical centerlines of single tires at opposite ends of axle, or between vertical centerlines of dual spacing (D.S.) at opposite ends of axle. |
| TIRE SECT (TIRE SECTION) | Overall width of new tire at top of tire under maximum load, including 24-hour inflation growth, and including protective side ribs, bars and decorations recommended by tire manufacturer. |
| D.S. (DUAL SPACING) | Dimension (width) between vertical centerlines of two tires (duals) assembled at one end of an axle. |
| TREAD + D.S.+ TIRE SECT (TREAD PLUS DUAL SPACING PLUS TIRE SECTION) | Overall width of axle, dual rims, and tire assembly at top of tires under load. |
| TREAD - D.S.- TIRE SECT (TREAD MINUS DUAL SPACING MINUS TIRE SECTION) | Distance (width) between near sides of inner tires of dual assembly at top of tires under load. |
| SLR (STATIC LOAD RADIUS) | Distance from ground to centerline of hub when tires are correctly inflated and under maximum load recommended by tire manufacturer. |

The charts shown here list tread information for various wheel/axle combinations. Tread dimensions are not dependent on tire size. Other dimensions explained here are related to tread and require tire dimensions. For tire dimensions, please contact your tire supplier.

REAR AXLES & REAR SUSPENSIONS

REAR AXLE TREAD

| WHEEL/RIM | | AXLE CODE | | | | | | |
|-----------|-----------------|-----------|---------------------------------------|---------|---|-------------------------------|---|---------|
| RIM TYPE | SIZE | MATERIAL | DUAL SPACING CAST OR CENTRIFUSE | 0014ATN | 0014ASB 0014ASD 0014GRJ 0014GTT 0014GTU | 0014HRG 0014HRR 0014HRH | 0014051, 0014AHE, 0014AHG, 0014ARB, 0014ASA, 0014ERB, 0014GGU, 0014GJD, 0014GJE, 0014GJH, 0014GJJ, 0014GJK, 0014GJN, 0014GRD, 0014GRM, 0014GRP, 0014GRR, 0014GRS, 0014GSX, 0014GTS, 0014GTW, 0014HRC, 0014HRE, 0014HRS | 0014GST |
| Disc | 22.5 x 8.25 | Steel | 13.24 | 90.41 | 74.16 | 78.17 | 72.54 | 80.12 |
| | | Aluminum | 13.18 | 91.31 | 75.15 | 79.07 | 73.44 | 81.02 |
| | 22.5 x 9.00 | Steel | 14 | 90.79 | 74.53 | 78.55 | 72.92 | 80.5 |
| | | Aluminum | 14 | 91.5 | 75.24 | 79.26 | 74.74 | 80.32 |
| | 22.5 x 12.25 | Steel | N/A | 90.79 | 74.53 | 78.55 | 72.92 | 80.5 |
| | | Aluminum | N/A | 90.66 | 74.4 | 78.42 | 72.79 | 80.3 |
| | 22.5 x 13.00 | Steel | N/A | 90.79 | 74.53 | 78.55 | 72.92 | 80.5 |
| | | Aluminum | N/A | 90.66 | 74.4 | 78.42 | 72.79 | 80.35 |
| | 24.5 x 8.25 | Steel | 13.24 | 90.41 | 74.16 | 78.17 | 72.54 | 80.12 |

NOTE: Dual Spacing is always the same between cast and centrifuse. Tread length decreases by approximately -0.5 in. with centrifuse drums.

REAR AXLES & REAR SUSPENSIONS

REAR BUMP HEIGHT CHART

| MODEL | REAR SUSPENSION | | | | SPINDLE TO BOTTOM OF FRAME | | |
|---|----------------------------|----------------|----------------|---------------------------|----------------------------|------------------|-----------|
| | TYPE | FEATURE CODE** | CAPACITY (LBS) | AXLE SPACING (6X4 OR 8X6) | UNLOADED - DR | LOADED - DR | BUMP - DR |
| 4x4 | Constant Rate | 14SAP | 23,000 | | 15.20 | 12.90 | |
| | | 14SAD | 30,000 | | 15.20 | 12.90 | |
| 6x4, 6x6 (Dimension shown is for 6x4 model unless otherwise noted) | Walking Beam | 14UHD | 40,000 | 54 | 9.70 | 8.50 | 7.3 |
| | | 14ULX | 40,000 | 54 | 10.56/16.56 W/ 6X6 | 9.5/15.5 W/ 6X6 | |
| | | 14UZS | 40,000 | 54 | 11.13 | 8.94 | 7.4 |
| | | 14UHK | 46,000 | 54 | 11.1/16.2 W/ 6X6 | 10.0/15.1 W/ 6X6 | |
| | | 14UHL | 46,000 | 60 | 11.1/16.2 W/ 6X7 | 10.0/15.1 W/ 6X7 | |
| | | 14ULY | 46,000 | 54 | 10.56/16.56 W/ 6X6 | 9.5/15.5 W/ 6X6 | |
| | | 14ULZ | 46,000 | 60 | 10.56/16.56 W/ 6X7 | 9.5/15.5 W/ 6X7 | |
| | | 14UMC | 46,000 | 72.5 | 10.56/16.56 W/ 6X8 | 9.5/15.5 W/ 6X8 | |
| | | 14UZT | 46,000 | 60 | 12.50 | 10.85 | 7.4 |
| | | 14UZU | 46,000 | 54 | 12.50 | 10.13 | 7.4 |
| | | 14UZV | 46,000 | 60 | 12.50 | 10.13 | 7.4 |
| | | 14698 | 52,000 | 54 | 12.2/16.0 W/ 6X6 | 11.2/15.0 W/ 6X6 | |
| | | 14524 | 65,000 | 56 | 13.00 | 12.00 | |
| | | 14667 | 65,000 | 60 | 13.00 | 12.00 | |
| | | 14ULN | 85,000 | 60 | 13.9 W/ 6X6 | 13.5 W/ 6X6 | |
| | 14UHU | 65,000 | 56 | 13.5/16.75 W/6X6 | 13.5/15.75 W/6X6 | | |
| | 14UNR | 85,000 | 60 | 14.20 | 13.20 | | |
| | 14UJE | 80,000 | 60 | 15.50 | 15.50 | | |
| | 14UZB | 46,000 | 54 | 12.50 | 10.85 | 7.4 | |
| | Rubber Spring Walking Beam | 14UYZ | 46,000 | 54 | 11.25 | 8.88 | |
| | | 14UZW | 46,000 | 72 | 12.50 | 10.13 | |
| | | 14UZX | 52,000 | 54 | 12.63 | 10.13 | |
| | | 14UZY | 52,000 | 72 | 12.63 | 10.13 | |
| | Air | 14UKZ | 40,000 | 55 | 9.50 | 9.50 | 6.3 |
| | | 14ULA | 40,000 | 60 | 9.50 | 9.50 | 6.3 |
| | | 14ULU | 40,000 | 55 | 9.50 | 9.50 | 6.3 |
| | | 14ULV | 40,000 | 60 | 9.50 | 9.50 | 6.3 |
| | | 14ULB | 46,000 | 55 | 9.50 | 9.50 | 6.3 |
| | | 14ULC | 46,000 | 60 | 9.50 | 9.50 | 6.3 |
| | | 14ULS | 46,000 | 60 | 9.50 | 9.50 | 6.3 |
| 14ULT | | 46,000 | 55 | 9.50 | 9.50 | 6.3 | |
| 14UNW | | 46,000 | 72 | 9.50 | 9.50 | 6.3 | |
| 14UNX | | 46,000 | 55 | 9.50 | 9.50 | 6.3 | |
| 14UNY | | 46,000 | 60 | 9.50 | 9.50 | 6.3 | |
| 8x6 | Air | 14VKD | 69,000 | 55 | 10.00 | 10.00 | |
| | | 14VKE | 78,000 | 55 | 10.00 | 10.00 | |

*Measurements are with a standard tire.

**Feature Codes Preceded with 00.

↶ return to table of contents

ELECTRICAL

BATTERY BOX LOCATIONS — RIGHT VIEW — 0008WKH W/ 0007BJC OR 0007DHJ (EGR)

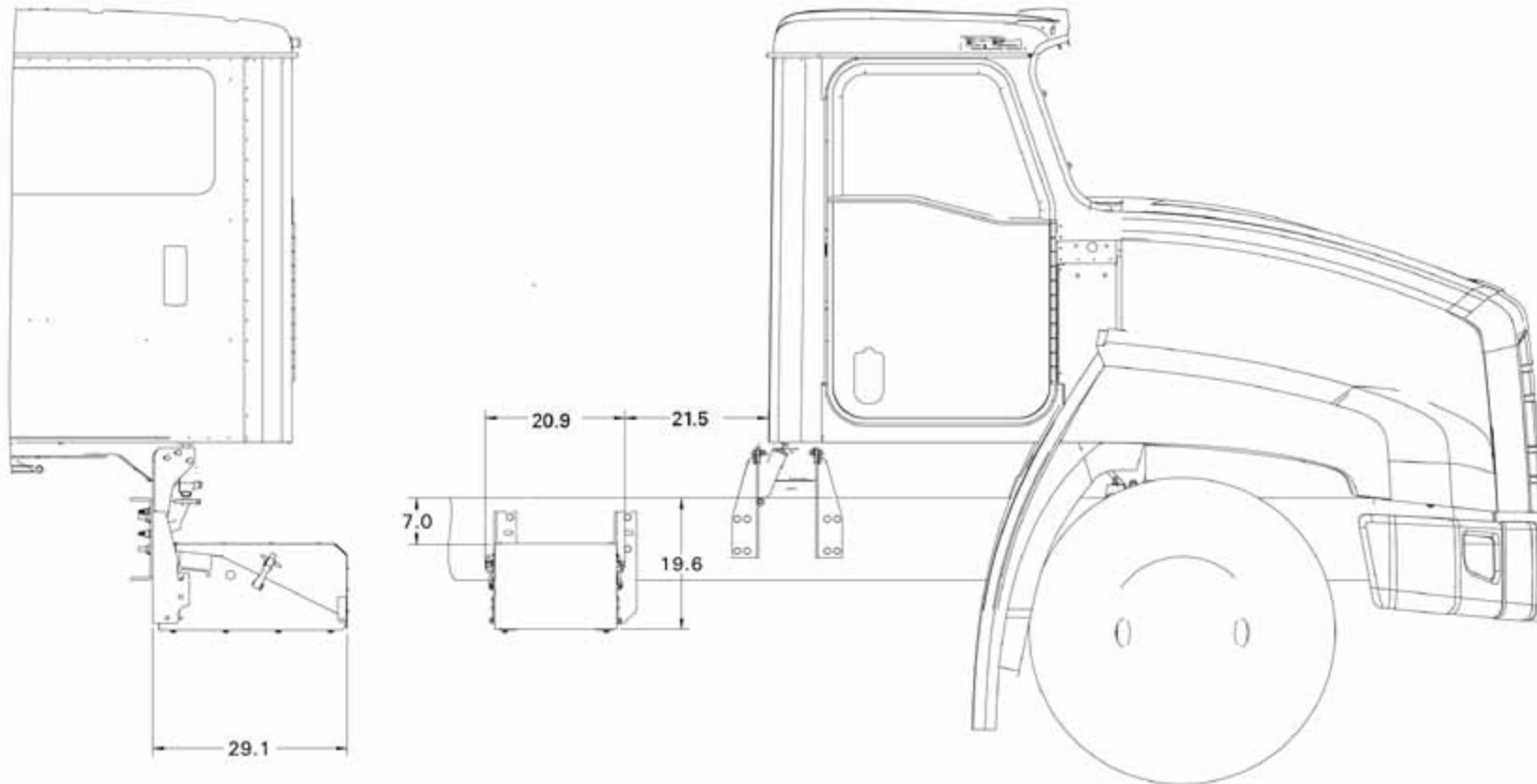

NOTE: All dimensions are with 0001CDH 3/8 Frame Rail.

[↶ return to table of contents](#)

ELECTRICAL

BATTERY BOX LOCATIONS — RIGHT VIEW — 0008WKH WITH DUAL FUEL TANKS (EGR)

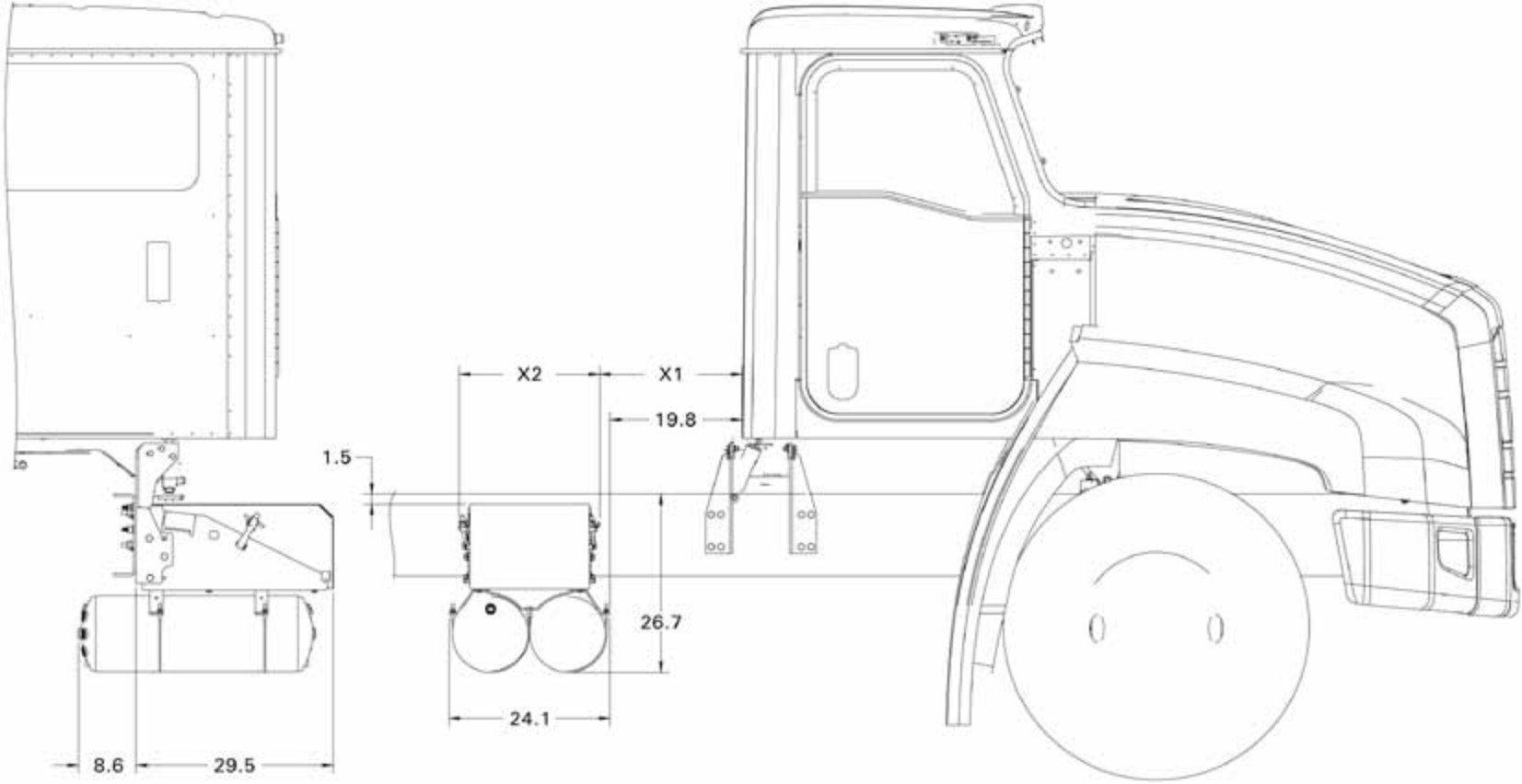

| | W/DUAL 60 OR 80 GALLON FUEL TANKS | W/DUAL 100 GALLON FUEL TANKS | W/DUAL 120 GALLON FUEL TANKS |
|----|-----------------------------------|------------------------------|------------------------------|
| X1 | 21.4 | 32.6 | 44.0 |
| X2 | 19.8 | 19.8 | 19.8 |

NOTE: All dimensions are with 0001CDH 3/8 Frame Rail.

[↶ return to table of contents](#)

ELECTRICAL

SCR BATTERY BOX LOCATIONS — RIGHT VIEW — 0008VUK WITH DUAL FUEL TANKS

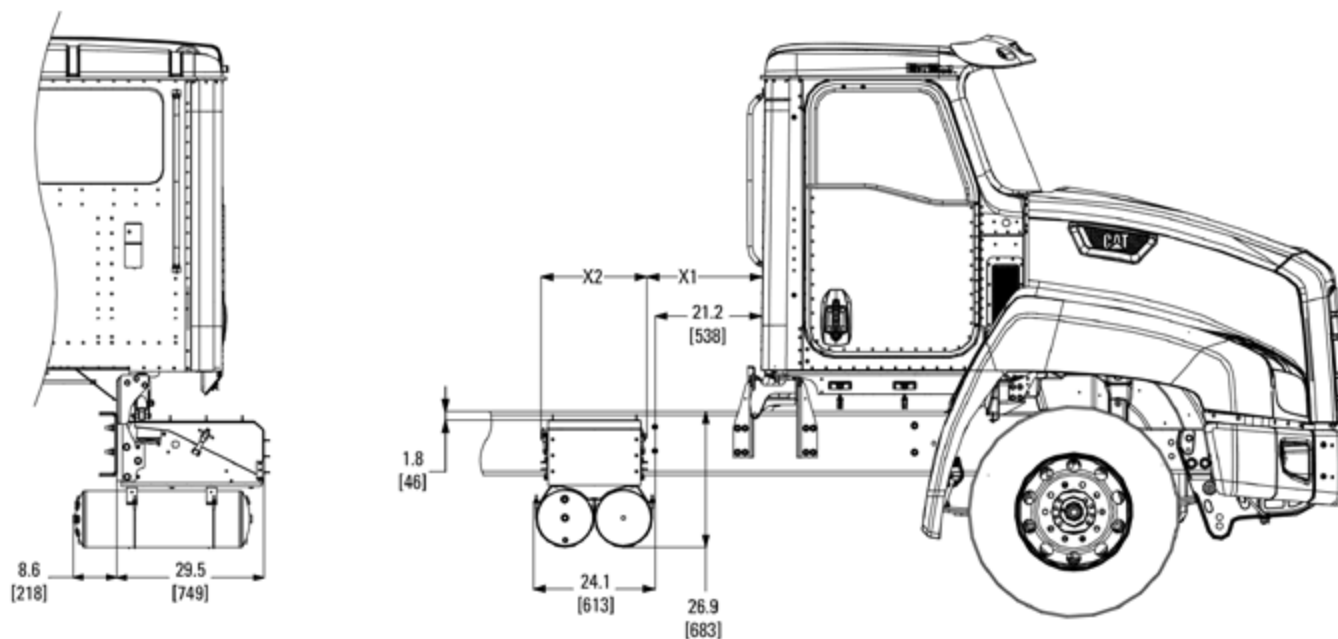

| | W/DUAL 60 OR 80 GALLON FUEL TANKS | W/DUAL 100 GALLON FUEL TANKS | W/DUAL 120 GALLON FUEL TANKS | 07BJU & 07DXM |
|----|-----------------------------------|------------------------------|------------------------------|---------------|
| X1 | 21.4 | 32.6 | 44.0 | 21.4 |
| X2 | 19.8 | 19.8 | 19.8 | 19.8 |

NOTE: All dimensions are with 0001CDH 3/8 Frame Rail.

[↶ return to table of contents](#)

ELECTRICAL

BATTERY BOX LOCATIONS

LEFT VIEW — W/0008WKE (EGR)

RIGHT VIEW – W/0008WKG & VERTICAL/VERTICAL EXHAUST (EGR)

LEFT VIEW —W/008WJN

RIGHT VIEW—W/008TST & VERTICAL/VERTICAL EXHAUST (SCR)

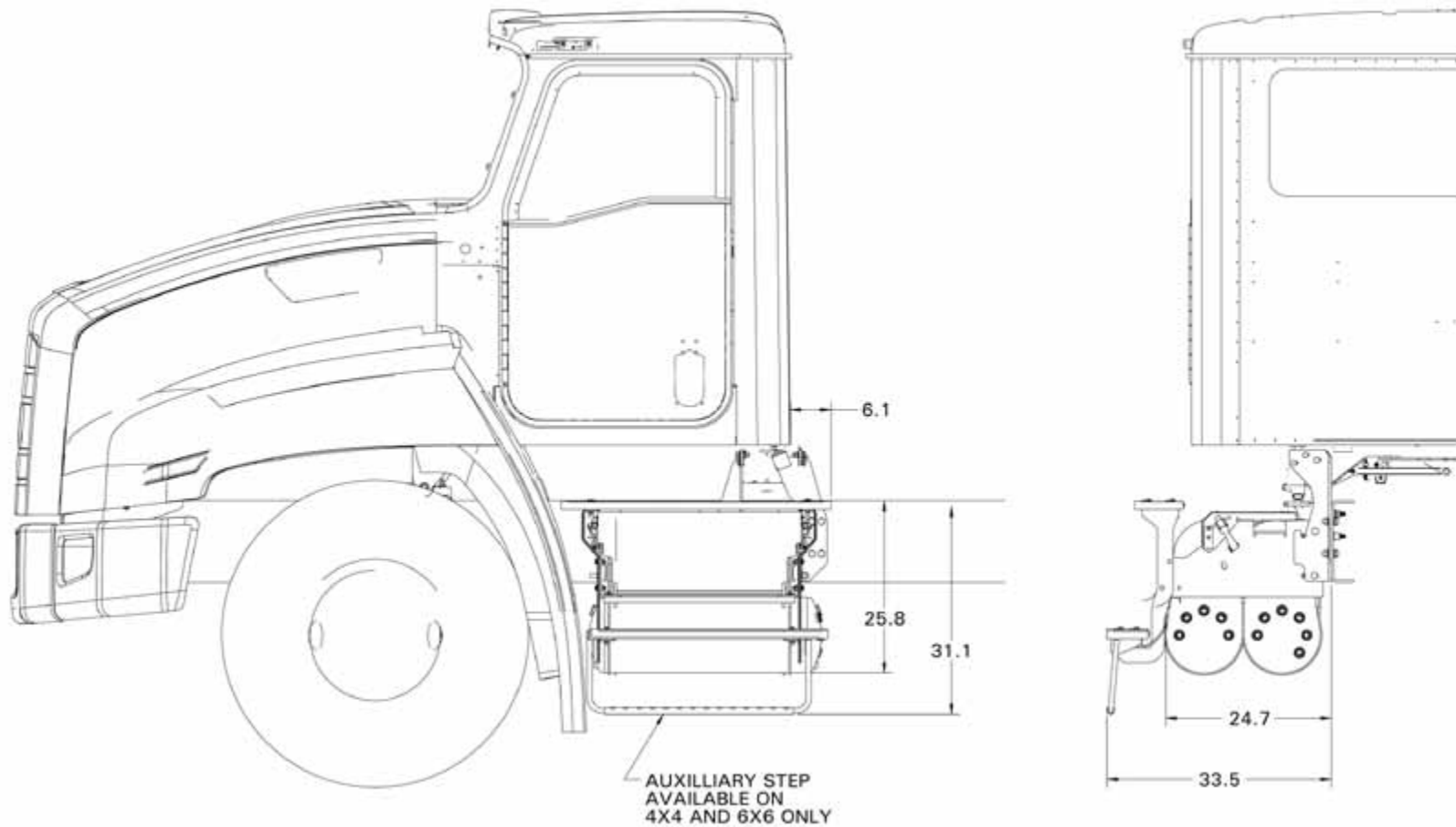

NOTE: A) Left side shown – right side symmetrically opposite.

B) All dimensions are with 0001CDH 3/8 Frame Rail.

[↶ return to table of contents](#)

ELECTRICAL

BODY BUILDER HARNESS FOR TAIL MARKER LIGHTS - 08HAB & 08HAE

This is the general description for the Body Builder Interface Harness for tail light systems including, rear running lights, marker and, stop lights, turn signals, switched power and ground. Each feature code provides two connectors. The round connector is a 7 way and one flat 3 way connector. The connectors will be secured by straps with a short amount of cable.

| 7 WAY CONNECTOR WIRING | | | |
|---------------------------------------|------------|------------|-------------------------------|
| Mating Connector Part Number 396-2814 | | | |
| Connector Pin | Signal | Wire Gauge | Mating Pin/Socket Part Number |
| A | Tail Light | 14 | 4163602 |
| B | Left Turn | 16 | 3962817 |
| C | Right Turn | 16 | 3962817 |
| D | Marker | 14 | 413602 |
| E | Backup | 16 | 3962817 |
| F | + Batt | 14 | 4163602 |
| G | Ground | 12 | 3962816 |

| 3 WAY CONNECTOR WIRING | | | |
|---------------------------------------|------------|------------|-------------------------------|
| Mating Connector Part Number 396-2886 | | | |
| Connector Pin | Signal | Wire Gauge | Mating Pin/Socket Part Number |
| A | Left Turn | 16 | 4394665 |
| B | Right Turn | 16 | 4394665 |
| C | Stop | 14 | 4173602 |

BRAKES

AIR TANK LOCATIONS — RIGHT VIEW — 0008WKH W/0007BJC OR 0007DHJ(EGR)

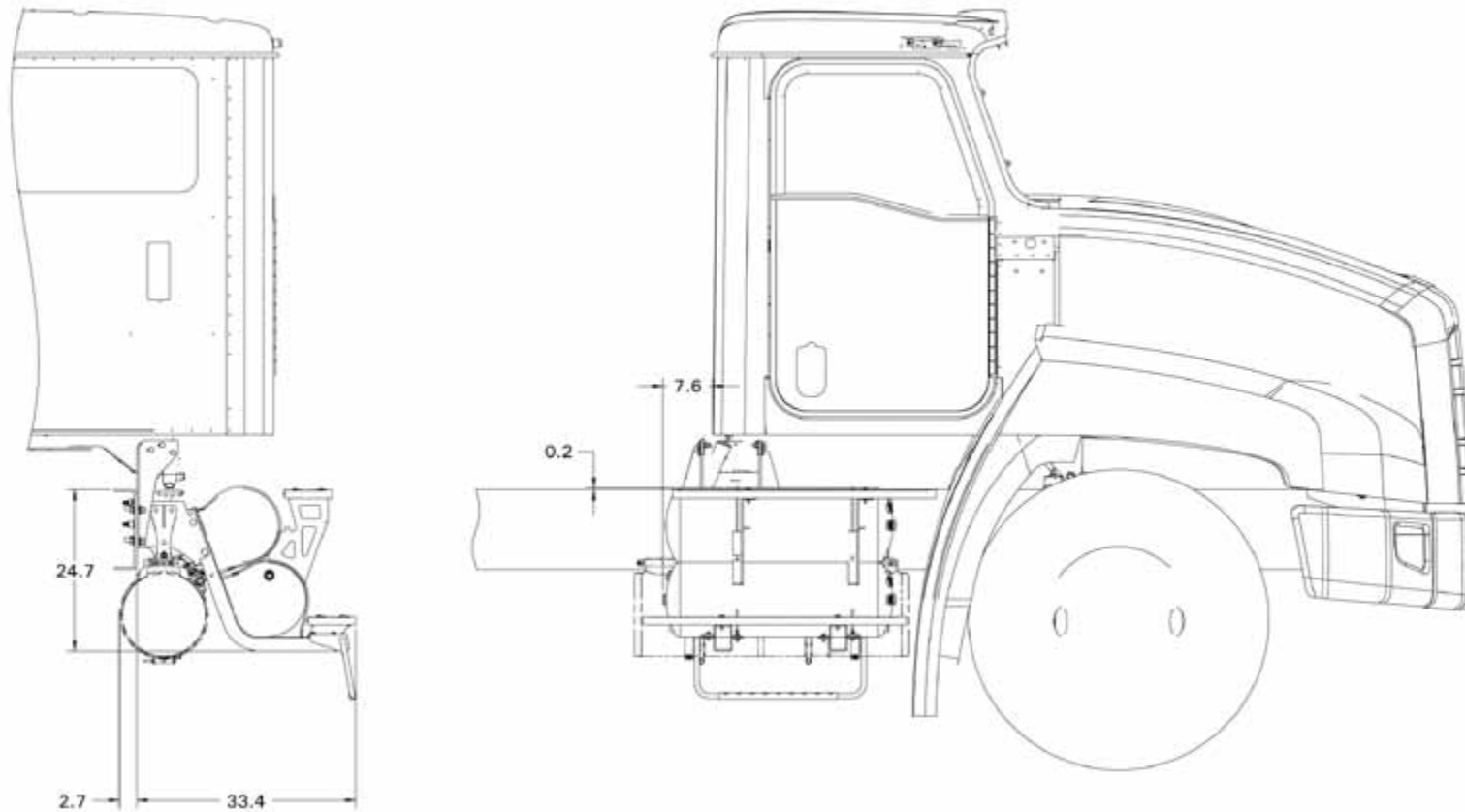

NOTE: All dimensions are with 0001CDH 3/8 Frame Rail.

[↶ return to table of contents](#)

BRAKES

AIR TANK LOCATIONS — W/OPTIONAL AUXILIARY AIR TANKS

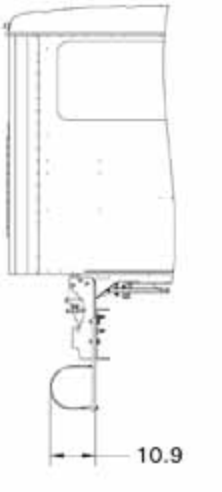
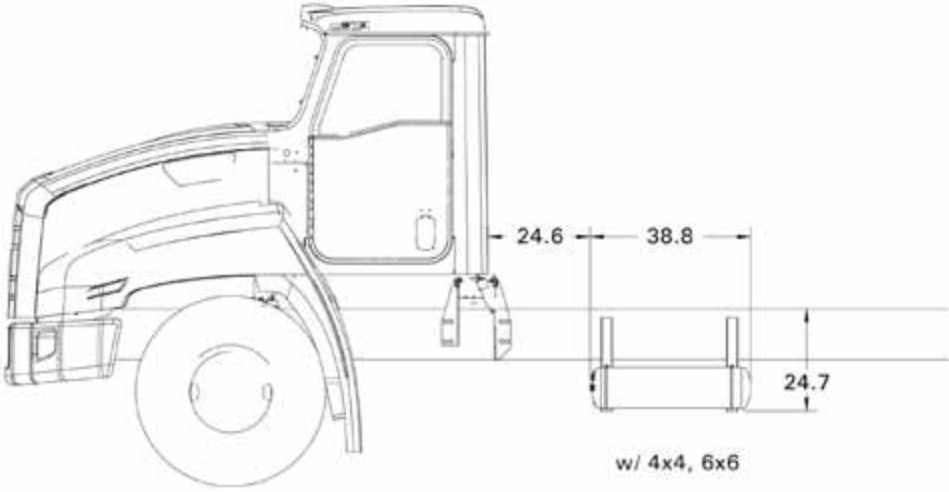
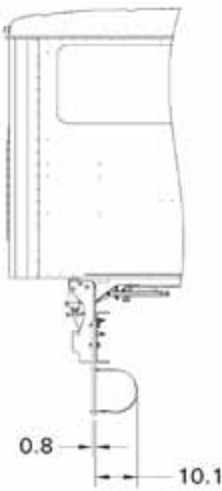
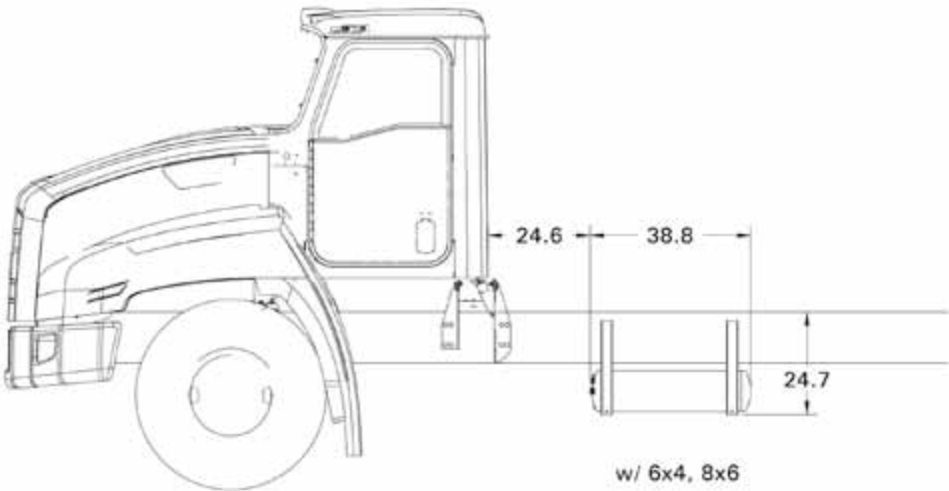

NOTE: All dimensions are with 0001CDH 3/8 Frame Rail.

[↶ return to table of contents](#)

BRAKES

AIR BRAKE MODIFICATIONS

Certification Procedures For DOT FMVSS-121

The Federal Department of Transportation's Motor Vehicle Safety Standard 121 required that virtually all trucks equipped with air brakes and manufactured on or after March 1, 1975 must comply with a comprehensive set of design and performance parameters concerning the air brakes and related systems. Of the many requirements of FMVSS 121, two are of primary concern between the truck manufacturer and the body and allied equipment manufacturer. The first concern is the center of gravity location on a truck used for compliance testing and the second involves the tubing and air flow design of the brake system.

Cautions — FMVSS-121 Air Brake System Modifications

CAUTION: If wheelbase alterations are made to Cat® vehicles with FMVSS-121 brakes:

- » **DO NOT** make alterations to air lines with hose, piping or fittings of sizes other than those currently in use on the truck.
- » **DO NOT** allow sharp bends or other constrictions in hosing.
- » **DO NOT** exceed the minimum or maximum wheelbase available from the factory for that model after lengthening or shortening the wheelbase. For wheelbases longer or shorter than those available from the factory, Caterpillar® will provide verbal opinion (through contacting your local Cat Dealer). Caterpillar will be available to provide certification testing and documentation of compliance or non-compliance with FMVSS-121 for the specific situation at an additional cost.

CAUTION: Air reservoirs may be relocated providing these guidelines are followed:

- » **DO NOT** make alterations to air lines with hose, piping or fittings of sizes other than those currently in use on the truck.
- » **DO NOT** allow sharp bends or other constrictions in hosing.
- » **DO NOT** alter brake line to port location.

CAUTION: Air-operated auxiliary attachments may be added to Cat FMVSS-121 vehicles if you:

- » **DO NOT** use air tap locations other than those shown on these drawings for these models.
- » Pressure protection valves are required where shown and should be mounted with the vent port downward. All new parts are available from Cat Truck Dealers. Since the FMVSS-121 has very specific criteria for the time allowed for air to reach and release the brakes, it is obvious that the tubing design is very critical and that the allowable sources for air tap must necessarily be restricted. Consult FMVSS-121 for criteria for time allowed for apply and release of brakes.

BRAKES

BRAKE RESTRICTIONS

Should it be necessary to modify the braking system, for example in connection with a wheelbase alteration, the following must always be observed:

- » Make sure that the brake circuits are not altered. Before any part of the braking system is dismantled, mark the brake tubes and connections concerned, or make a sketch showing the original routing.
- » Avoid joints or couplers, preferably change the entire brake tube/hose.
- » Preferably, use bent brake tubes instead of elbow unions so as not to affect the brake application/release times.
- » Install the brake tubes in positions where they are protected against damage and heat.
- » Install the air tanks so that the drain valves still function well and are easy to reach.

CAUTION: When a brake tube is replaced or jointed, use only genuine Cat® parts of the correct type.

NOTE: On trucks with ABS brakes, the sensor cable must not be jointed. If necessary, it must be completely replaced.

BRAKES

ANTI-LOCK AIR BRAKE SYSTEM SCHEMATIC — W/TRUCK AIR BRAKE SYSTEM CODE 04091

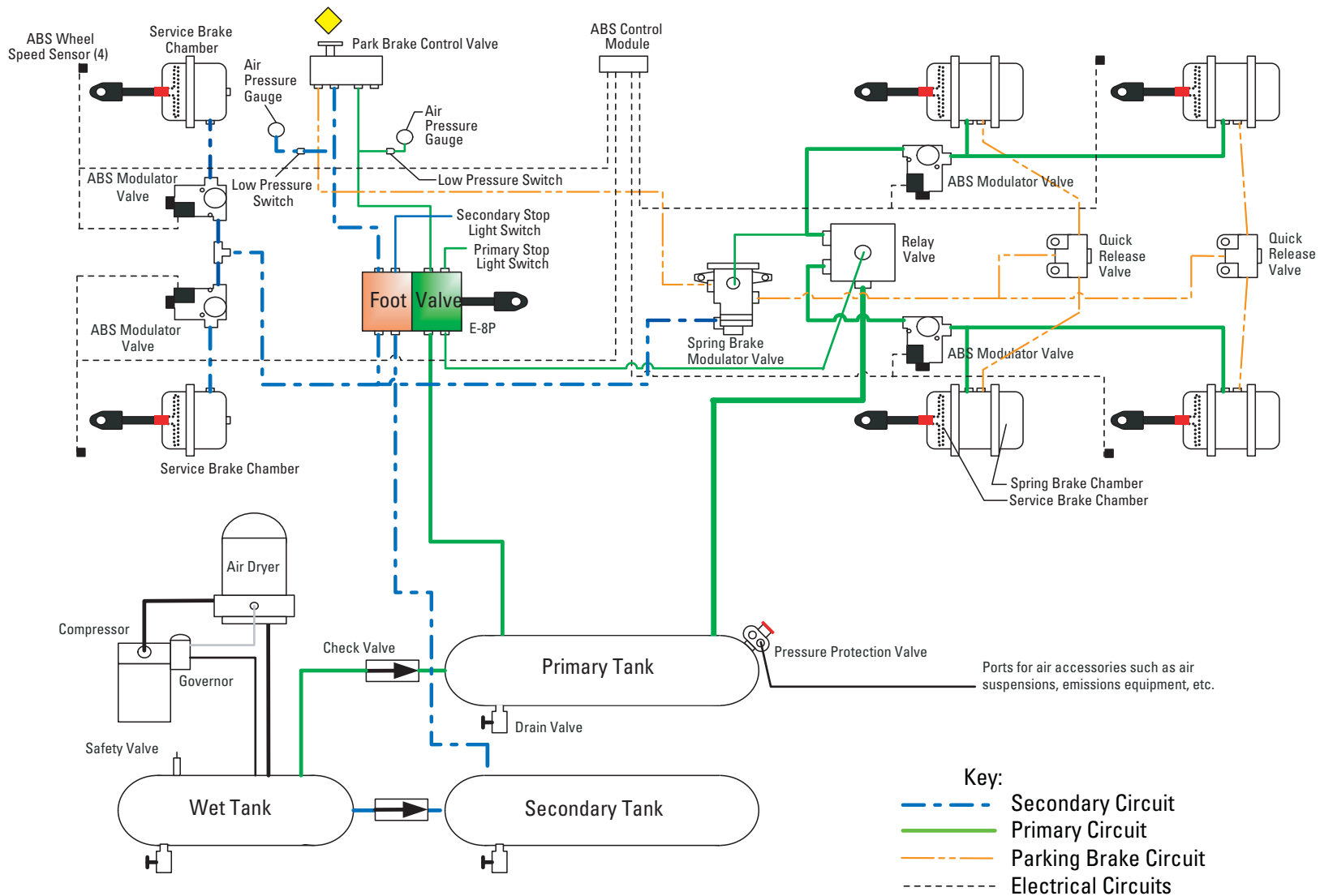

BRAKES

ROUTING GUIDELINES

If modifications are made to Cat® vehicles with the addition or re-routing of tubing the following guidelines found in the Federal Motor Carrier Safety Regulations Pocketbook, section 393.45, should be followed. Tubing must:

- » Be designed and constructed in a manner that insures proper, adequate, and continued functioning of the tubing or hose.
- » Be installed in a manner that insures proper continued functioning of the tubing or hose.
- » Be long and flexible enough to accommodate without damage all normal motions of the part to which it is attached.
- » Be suitably secured against chafing, kinking, or other mechanical damage.
- » Be installed in a manner that prevents it from contacting the vehicle's exhaust system or any other source of high temperatures.
- » Caterpillar® Route and Clip standards state that tubing shall be a minimum of 5 inches away from the aftertreatment inlet and a minimum of 3" away from the aftertreatment outlet.

BRAKES

AIR-OPERATED AUXILIARY ATTACHMENTS

- » The primary air reservoir has two dedicated ports for two-port pressure protection valves (PPV). There will always be a PPV installed in Port “A” shown below. The additional PPV in Port “B” will come installed from the factory if more than 3 air operated accessories are ordered (i.e. air suspension, air suspension dump, fifth wheel slide, etc.).
- » In some cases, one of the ports on a PPV may be plugged. This plug may be removed to insert an additional line. If all of the ports on the PPV are utilized, then a quality connect tee should be installed into one of the used ports. The recommended tee – 3/8 inch x 3/8 inch x 3/8 inch stem (Cat® part number 3580230) – can be ordered from a Cat Dealer.

View displaying pressure protection valve in primary air tank with 2 supply lines.

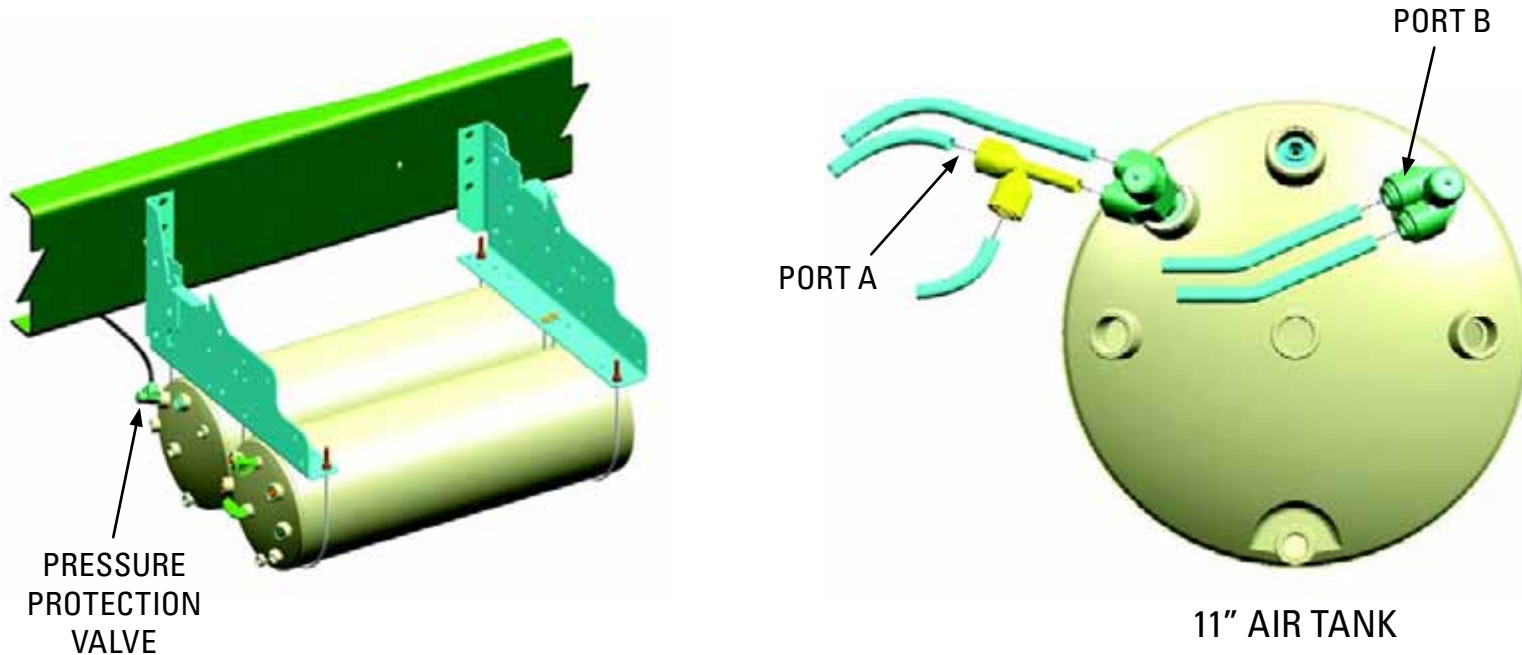

BRAKES

TUBE FITTING INSTALLATION INSTRUCTIONS

The majority of tube fitting connections in the air braked chassis utilize a Quality Connect fitting (fitting integral to an air brake component or plastic fitting) or a PTC fitting (fitting threaded into an air brake component). Both of these fitting types are comprised of a collet which bites into the tube to hold it firmly in place and a fitting O-ring which seals the tube to the valve, manifold or tee body to prevent leakage. To aid in service, a kit is available with tools for each port and tube size used by Caterpillar®.

To assure standardization of tubing used on Cat vehicles, the following table illustrates tubing color, abbreviations and where that color is used.

| COLOR | ABBREVIATION | WHERE USED |
|--------|--------------|--|
| Black | BK | MV-3, PPDC Exhaust, Air Seat, Air Horn, Air dryer to Wet Tank, Wet Tank to Governor, Lift Axle Tank Supply |
| Blue | BL | Trailer Service, 1st Pusher Delivery |
| Brown | BN | Air Suspension System, 2nd Pusher Delivery |
| Green | GN | Primary Brake System |
| Orange | OR | Secondary Brake System |
| Purple | PL | 1st Tag Delivery, Engine Wastegate Control |
| Red | RD | Trailer Emergency |
| Silver | SIL | PDL Control, 2nd Pusher Supply, Governor to Dryer |
| Tan | TN | Locking Differential, 1st Pusher Supply, Traction Differential, Two-speed axle |
| White | WH | Load Sensing Gauge, 1st Tag Supply |
| Yellow | YL | Spring Brake System, Cab Air Suspension |

BRAKES

REMOVAL AND INSERTION PROCEDURES FOR TUBING IN QC OR PTC FITTINGS



WARNING: Do not attempt to disassemble tubing from fittings with air pressure in the system. Failure to drain system of air pressure before removing components may cause personal injury or death.

Removal of Tube from Fitting

- » Use the tube release tool (see graphic 1 below) to remove the tube.
- » Push down on the release tool, then pull on the tube. Pushing the tool depresses the fitting collet, allowing it to release the tube. Sometimes the brass tube support will be pulled out of the fitting when the tube is removed. Be sure to reinstall a tube support when installing the tube.

Preparation of Tube for Installation

- » Inspect the tube end for external scratches, burrs, or cracks. If it is damaged, trim the damaged portion off at an insertion depth mark (see graphic 2 below) or replace the tube. **DO NOT** reuse a damaged end.

IMPORTANT: Use the tube cutter (supplied in the tool kit) to ensure that the cut is square within 15° to help prevent leakage. Do not use a dull or heavy cutting tool such as side cutters, pocket knife or hack saw which could collapse (flatten) the tube or create O-ring damaging burrs. Do not use the tube cutter to cut anything other than nylon air line tubing. Replace the blade or cutter if the cutting edge becomes dull.

Installing Tube Into The Fitting

- » Lubricate the tube end and install it to the correct insertion depth (see graphic 3 below). Install the tube by pushing it straight into the fitting. The insertion depth mark should be flush with the face of the fitting (see graphic 3 below). Gently tug on the tube to make sure it is secured in the fitting.
- » Test to make sure the assembly is free from leaks using a soap solution and clean, dry air at system pressure. When performing a bubble test, leakage should not exceed a soap bubble of 1/2-inch (12 mm) in 3 seconds with system air pressure of 100 to 130 psi. If a leak exceeding the above specification is still present, remove and replace the valve, manifold or tee.

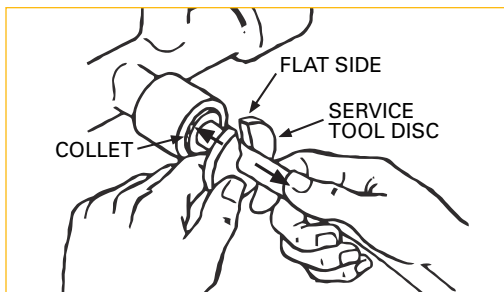

1) Remove Tube



2) Prepare for Installation

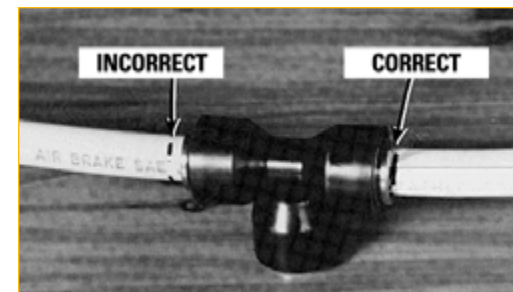

3) Install Tube into the Fitting

[↶ return to table of contents](#)

BRAKES

AIR BRAKE TUBING – FRONT SECTION

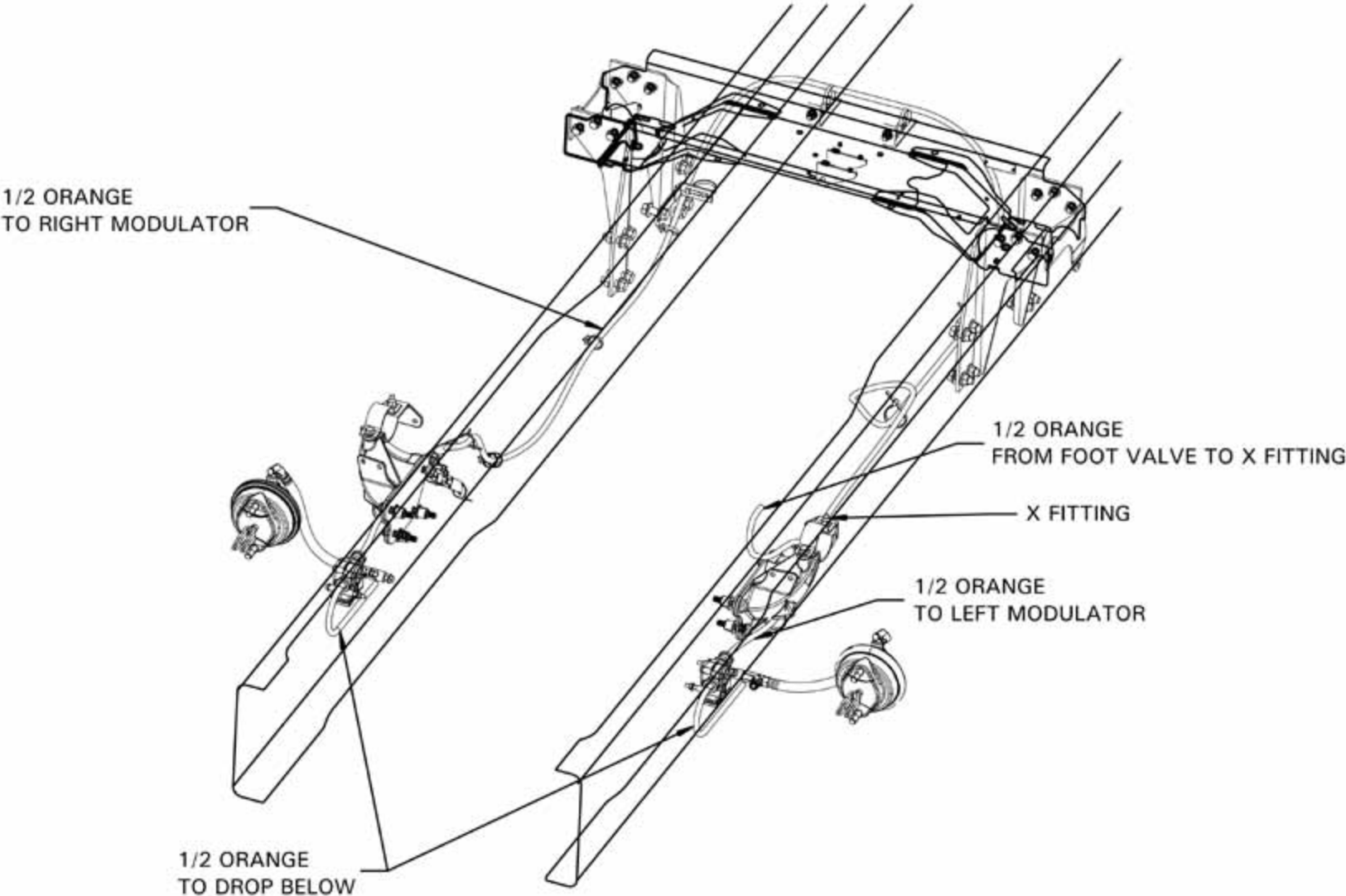

BRAKES

AIR BRAKE TUBING – REAR SECTION

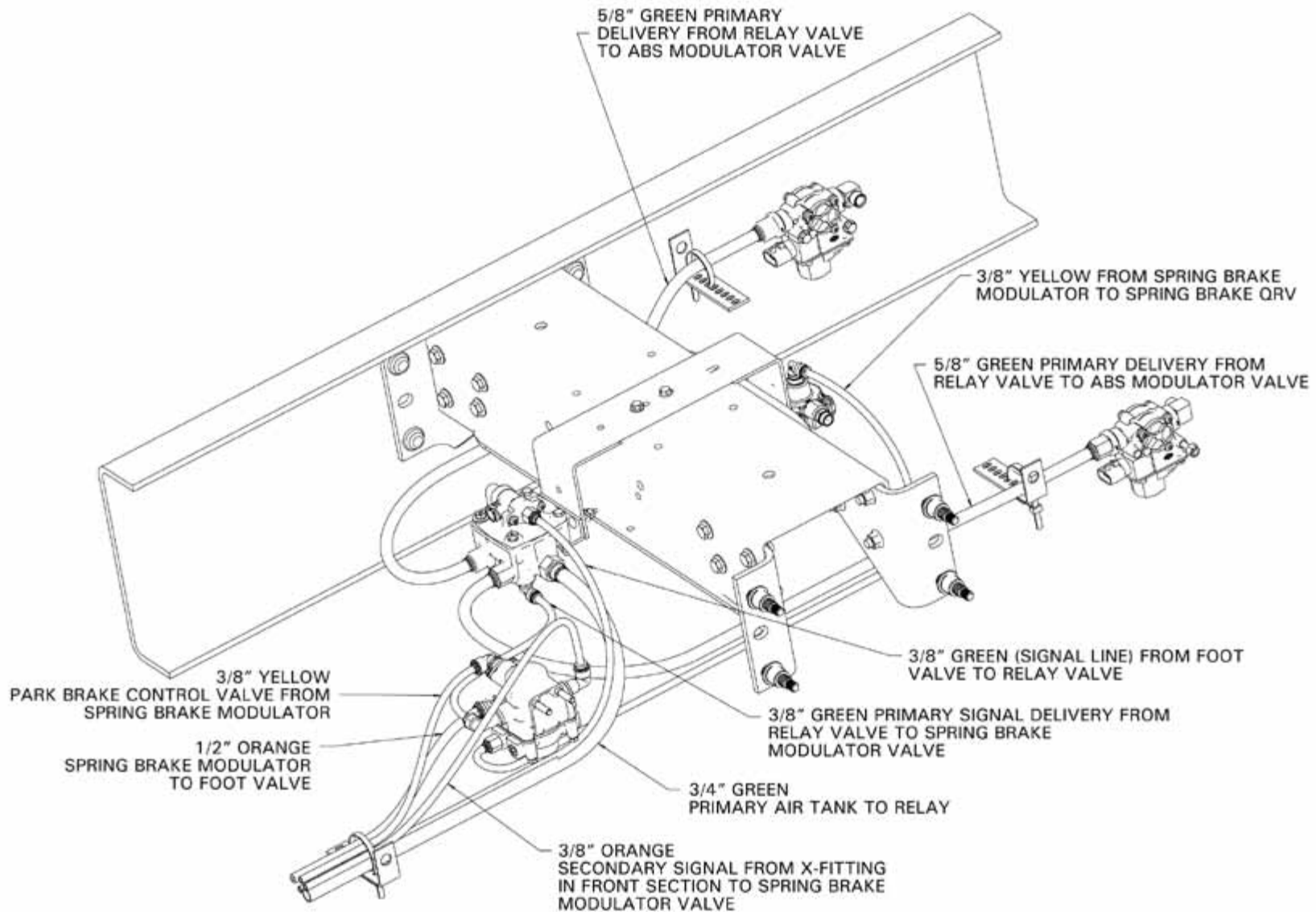

BRAKES

INSIDE CAB VALVE PLUMBING

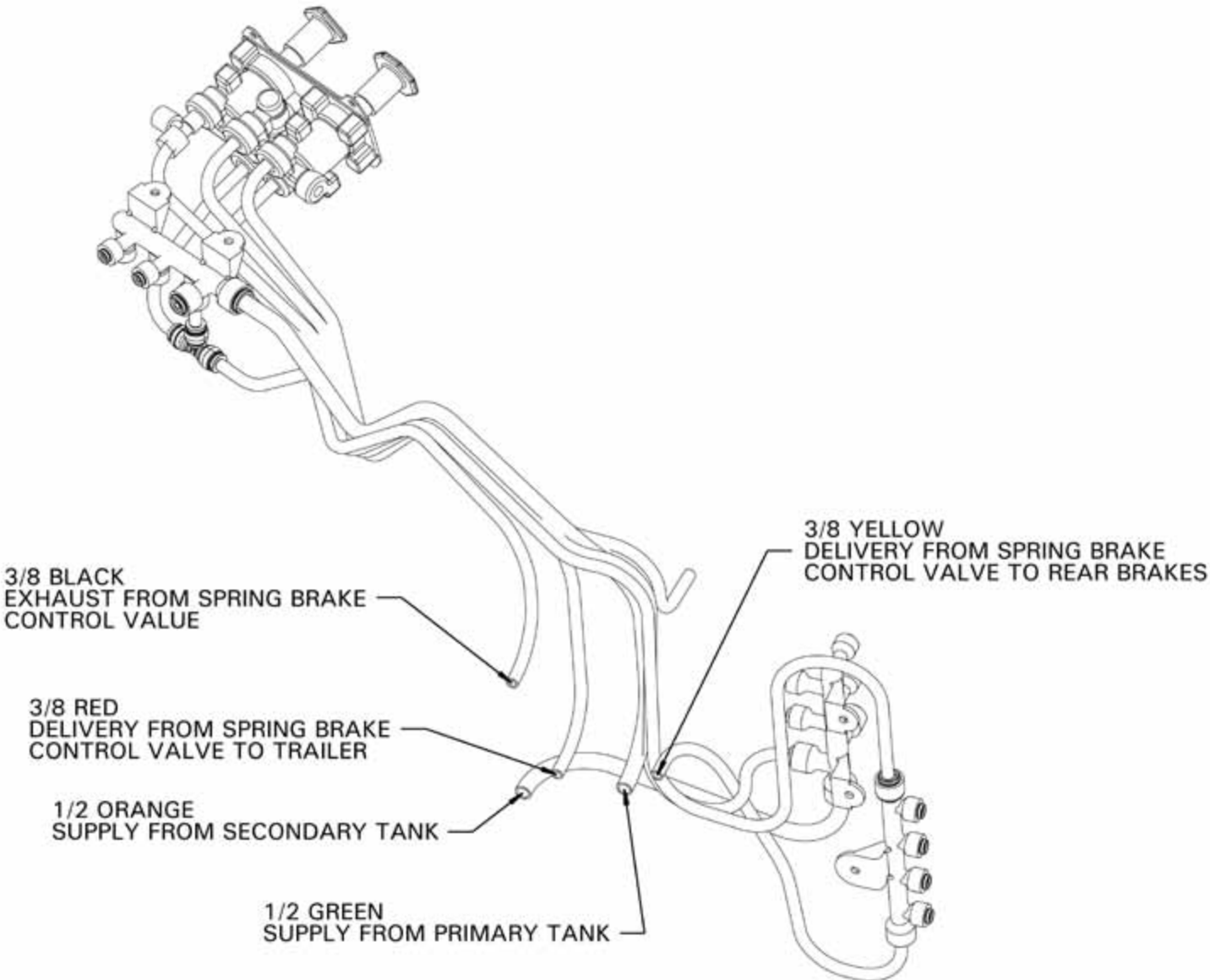

BRAKES

FOOT VALVE PLUMBING

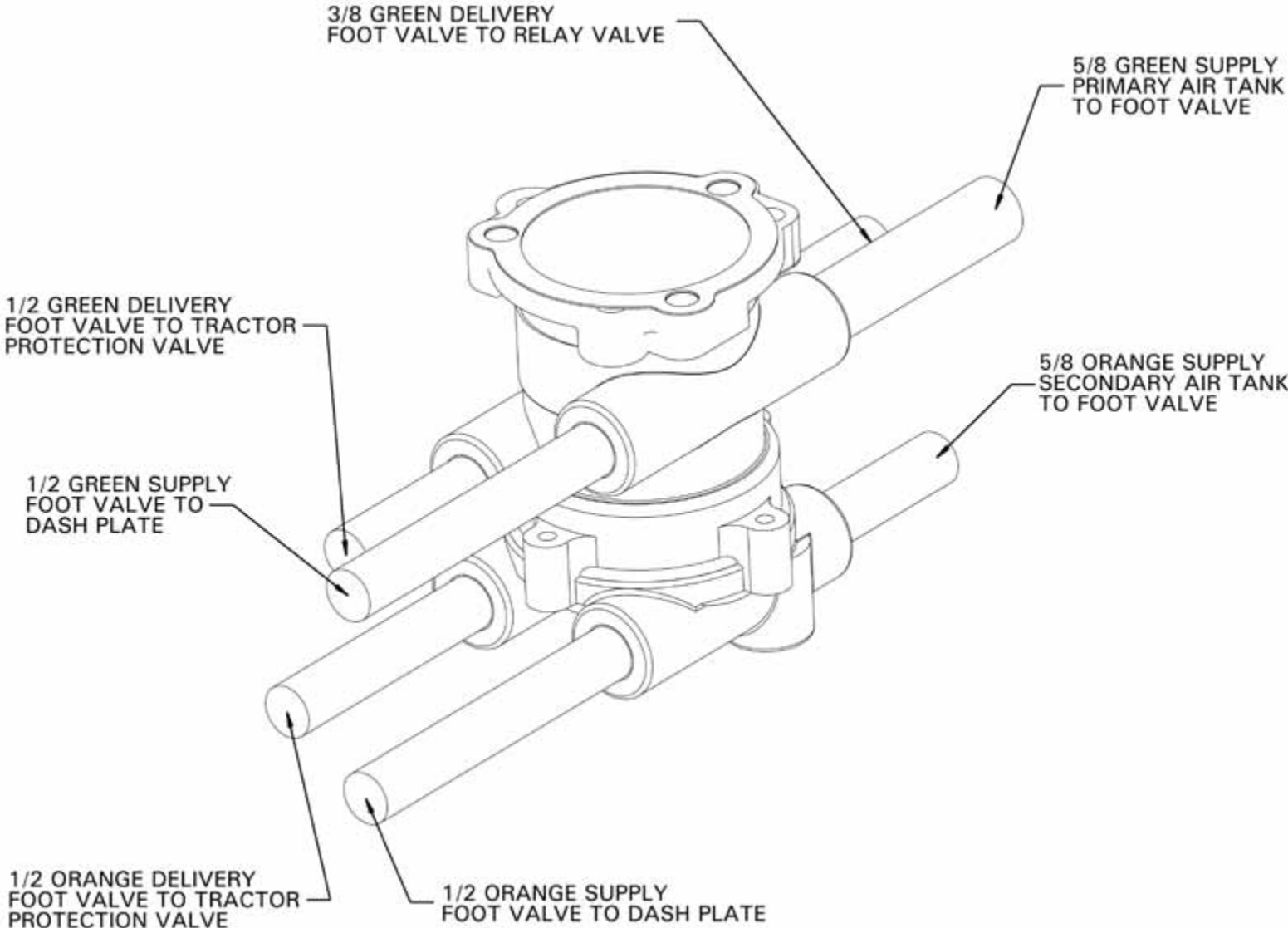

BRAKES

CT11/13 AIR DRYER LOCATIONS

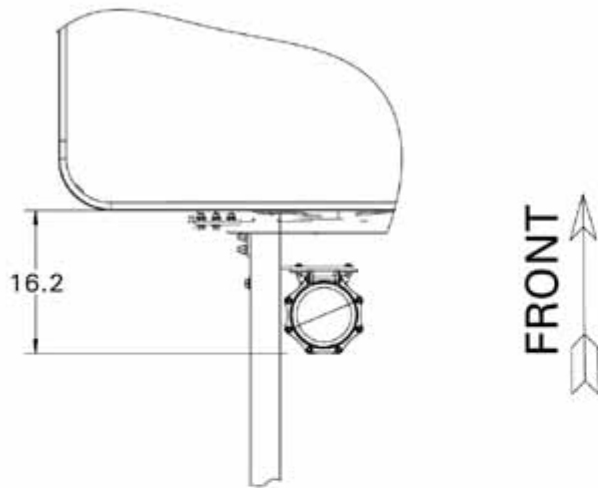

0004EBS
BENDIX AD-9

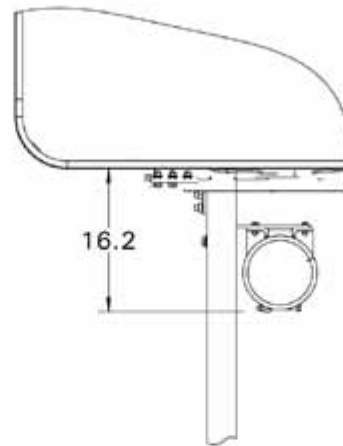
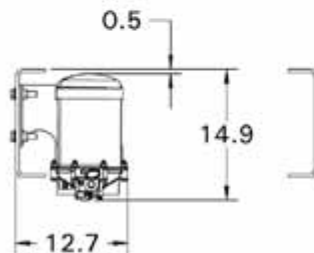

0004EBT
BENDIX AD-IP

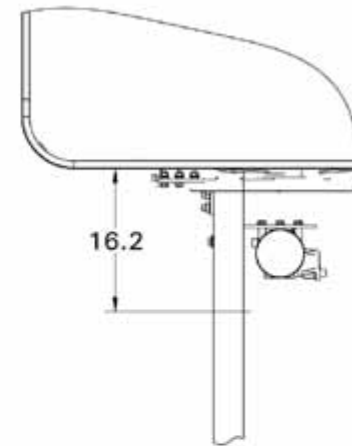
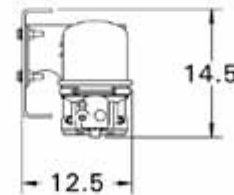

0004EBD
MERITOR WABCO
SYSTEM SAVER 1200

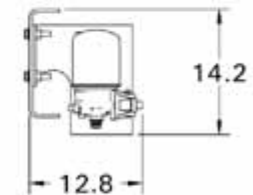

NOTE: All dimensions are with 0001CDH 3/8 Frame Rail.

[↶ return to table of contents](#)

BRAKES

CT13 SCR AIR DRYER LOCATIONS - 07BJU & 07DXM

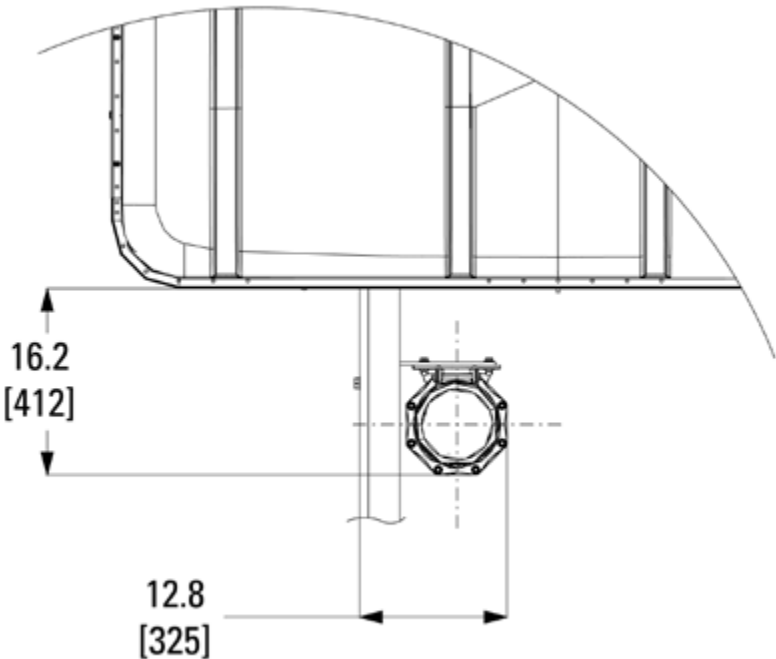

NOTE: All dimensions are with 0001CDH 3/8 Frame Rail.

BRAKES

CT15 AIR DRYER LOCATIONS

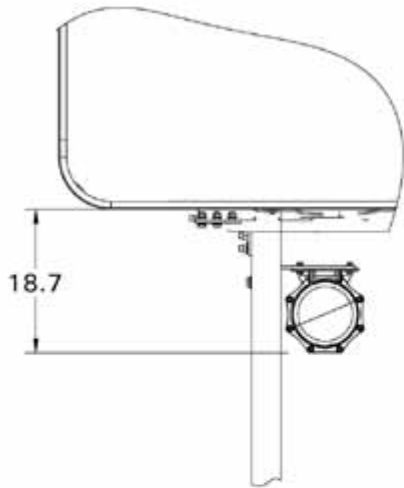

0004EBS
BENDIX AD-9

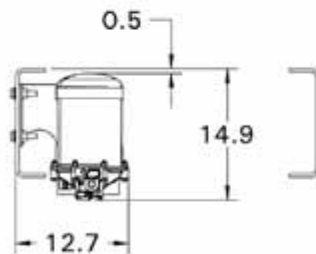

FRONT
↑

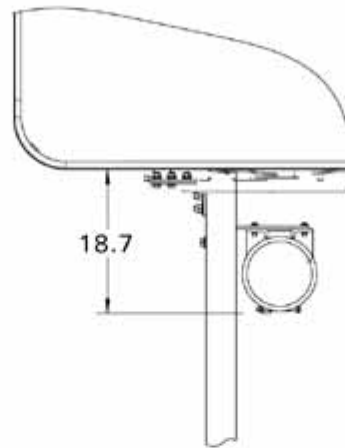

0004EBT
BENDIX AD-IP

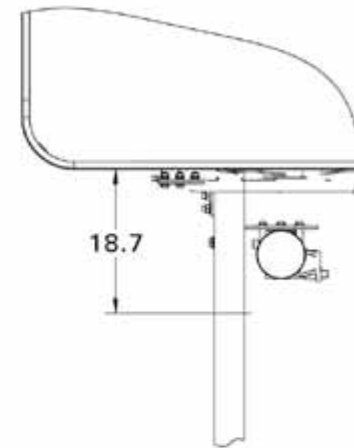
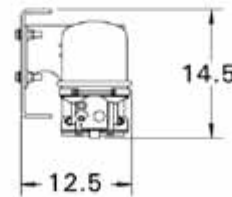

0004EBD
MERITOR WABCO
SYSTEM SAVER 1200

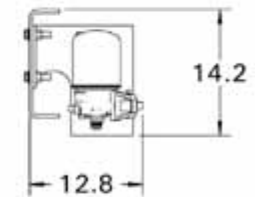

NOTE: All dimensions are with 0001CDH 3/8 Frame Rail.

↶ return to table of contents

STEERING

STEERING GEAR LOCATION/DIMENSIONS — SHEPPARD M-100

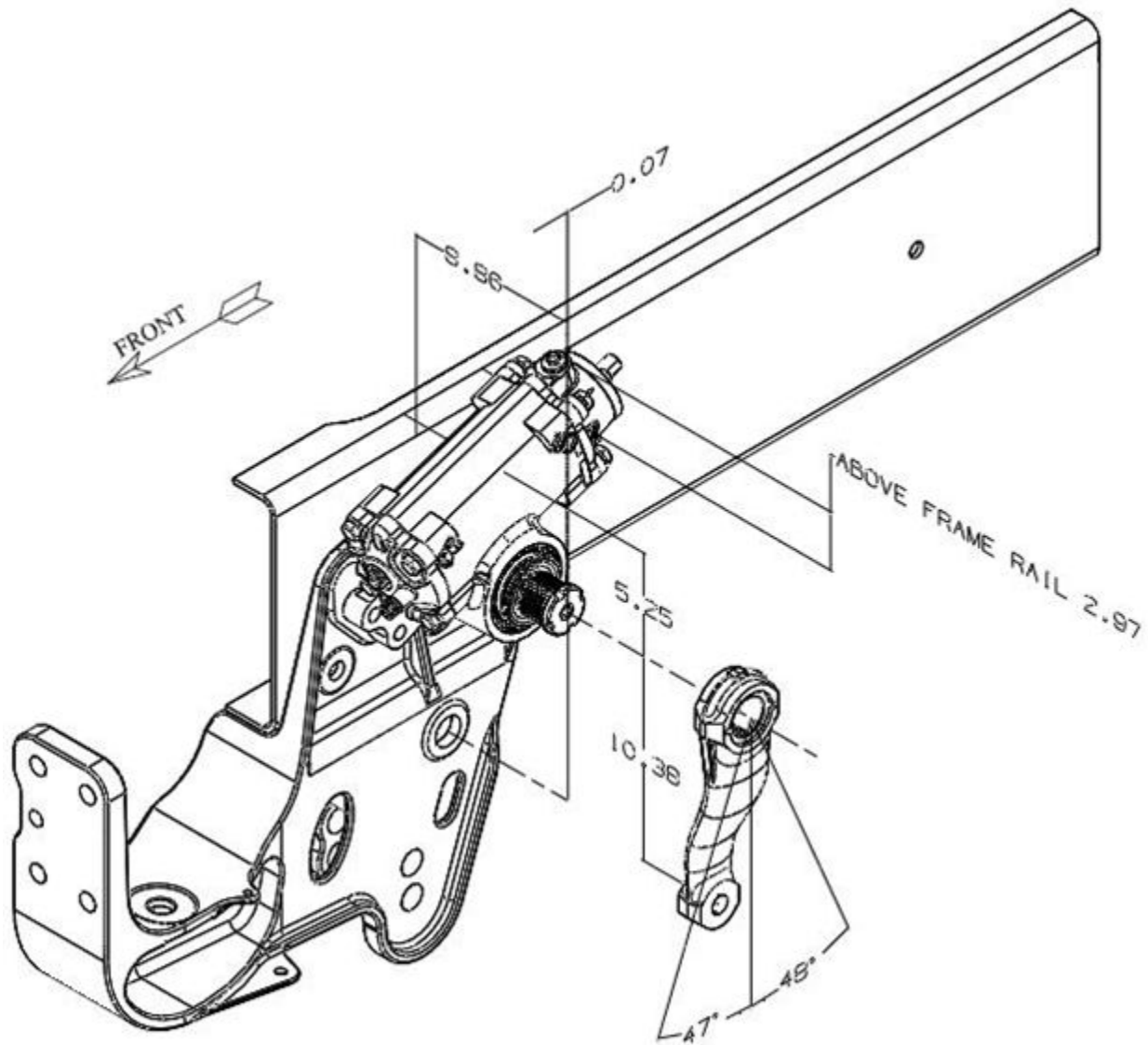

STEERING

STEERING GEAR LOCATION/DIMENSIONS — SHEPPARD M-100/M-80

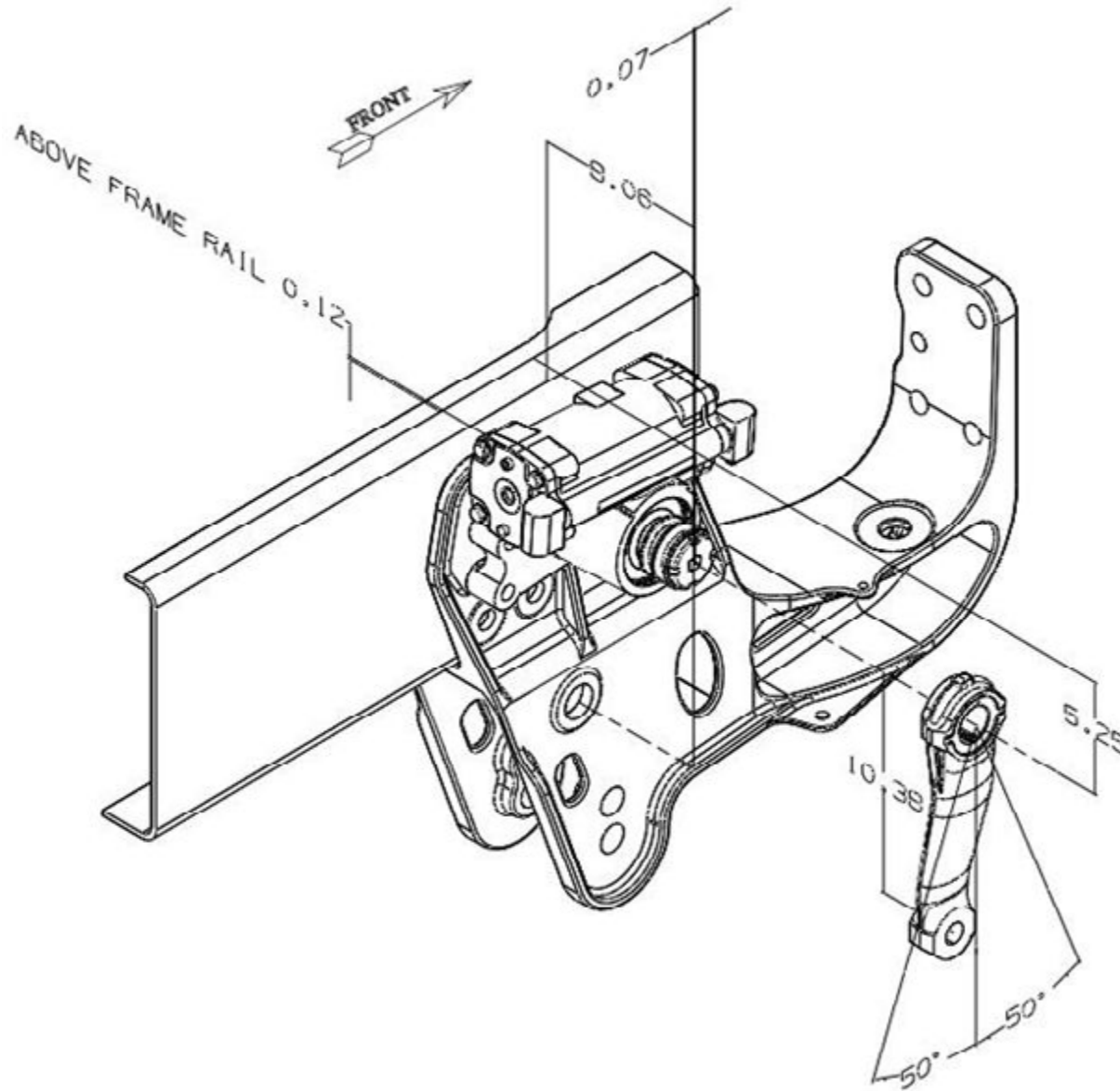

STEERING

STEERING GEAR LOCATION/DIMENSIONS — SHEPPARD M-110/M-80

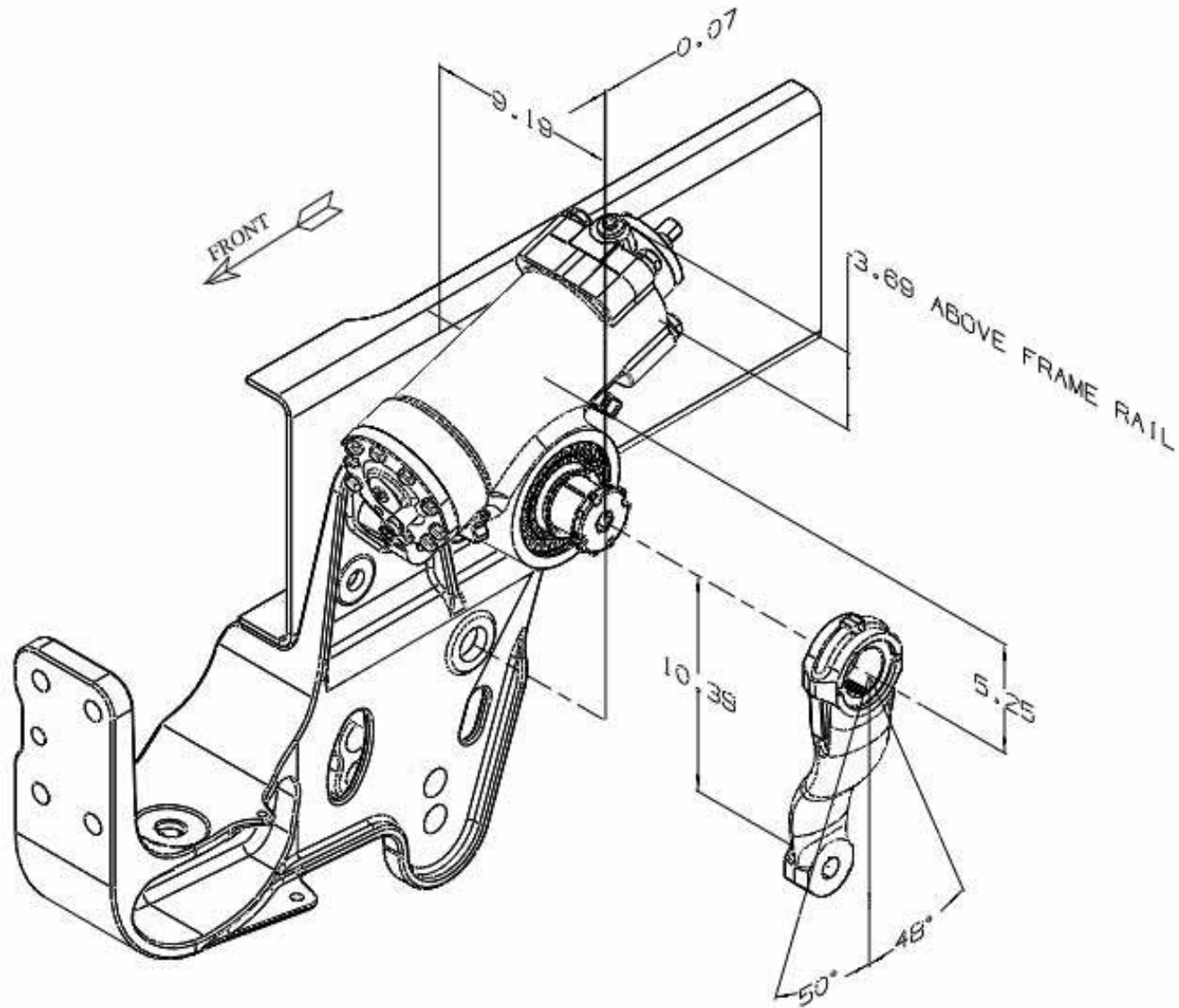

EXHAUST

GUIDELINES FOR AFTERTREATMENT MODIFICATIONS

Caterpillar has a responsibility to supply, install and ensure that the engines and aftertreatment emission control devices comply with the certification requirements of the U.S. Environmental Protection Agency (EPA) and the California Air Resources Board (ARB). The aftertreatment devices may include a combination of particulate filters, catalysts, catalytic converter, and temperature and pressure sensors, along with other components.

Proper long-term operation of these components requires controlling exhaust stream temperatures and the exhaust flow pattern throughout the system. This controls the required location of the components as well as the insulation of the various parts of the system.

For this reason, application guidelines for aftertreatment and tailpipe installations are much more complex and restrictive than in the past.

Caterpillar will ensure correct factory installation of aftertreatment devices to assure compliance with the certification requirements.

Modified systems could damage the engine, aftertreatment system and other truck systems and void the warranty coverage. In that regard, Caterpillar will make it a policy to procure and correctly install the appropriate aftertreatment devices pursuant to applicable specifications and application guidelines. That brings with it the benefit of certified systems that will be fully covered under warranty provided the vehicle is properly maintained and not modified beyond the extent allowed by the Body Builder book.

The following guidelines are meant to clarify the allowable modifications for aftertreatment systems. Please consult applicable federal, state and local laws and requirements in conjunction with this document to ensure compliance to those requirements. Also, refer to applicable vehicle warranty information before performing any modifications to the vehicle. Non-compliance to the requirements of the warranty may nullify it in its entirety.

- » Where possible, trucks first and foremost should be ordered directly from the factory that meets the body installation requirements so that the minimum, or no modification of the exhaust system will be required.
- » Where this is not possible, if another exhaust configuration is available from the factory that closer meets the need of the body installation, it is permissible to completely replace one exhaust configuration with the better choice exhaust system provided that would have been available with the same engine, and the clearance guidelines in this reference are followed.
- » Exhaust Gas Temperatures may be as high as 800° C during vehicle operation. Precautions should be taken to ensure that materials used in the vicinity of the exhaust system and exhaust gas stream can withstand these temperatures or are safely shielded.

EXHAUST

TAILPIPE, CLEARANCE CHARTS

Meeting Legal Requirements

It is the responsibility of the person performing modifications to the vehicle to ensure that the vehicle, in its final configuration, conforms to any applicable law regarding emission control, noise level and applicable safety standards.

Significant Changes for Vehicles Produced to Meet U.S. 2007 EPA Requirements

Turbo Pipe

The function of the Turbo Pipe is to deliver exhaust gases from the engine to the Aftertreatment Module so that temperature losses are minimized and so that the flow pattern of the exhaust gases maximizes the efficiency of the Aftertreatment Module. Any modifications to this piping without written approval of Caterpillar, may significantly reduce the performance of the Aftertreatment Module and VOID any applicable warranty. All Modifications to Turbo Pipe Location, Geometry and Materials MUST be approved by Caterpillar.

If so equipped, heat shields and protective wraps must be maintained on the vehicle to ensure the proper performance of the Aftertreatment Module and for the protection of the installed truck systems. Never mount any additional harnesses or other equipment to the Aftertreatment Module.

Aftertreatment Module

The function of the Aftertreatment Module is to catch soot exhausted from the engine and convert it to ash. It is critical that the temperature and pressure sensors' wiring remain intact for the Aftertreatment Module to perform as designed. It is critical to maintain the location of the Aftertreatment Module as installed from the factory to ensure its proper operation. Any modifications to the Aftertreatment Module without the written approval of Caterpillar, may significantly reduce the performance of the Aftertreatment Module and VOID any applicable warranty.

All Modifications to Aftertreatment Module Location, Geometry, Materials, Wiring, Sensors or Tubing MUST be approved by Caterpillar. If so equipped, heat shields and protective wraps must be maintained on the vehicle to ensure the proper performance of the Aftertreatment Module and for the protection of the installed truck systems. Never mount any additional harnesses or other equipment to the Aftertreatment Module.

EXHAUST

TAILPIPE, CLEARANCE CHARTS

Exhaust Piping Modifications

Never modify the internal structure of the Turbo Pipe, the Aftertreatment Module or the Temperature Control Device. When lengthening or shortening tailpipes beyond the Aftertreatment Module, observe the following precautions:

- 1) Use the same size and material to extend or shorten the original pipe.
 - » Refer to Table 1 for proper material and sizing of pipes when extending or shortening tailpipe sections.
- 2) Adding additional extensions and bends will change internal exhaust gas pressure, which could result in damage to the Aftertreatment Module or other engine components as well as a reduction in fuel economy.
 - » Use the worksheets provided to compute the change in backpressure of the modified exhaust piping. Ensure that the limits within the worksheet are met to avoid performance issues and to maintain warranty of the engine and aftertreatment system.
- 3) Support additional piping using rubber mounts approved by Caterpillar (P/N 3608413 Isolator and P/N 3627166 Metal Sleeve). Add one additional support for every 4 linear feet of exhaust piping added, evenly spaced along the length of the chassis.

Route all piping with minimum clearances to other chassis components as shown in Table 2.

Mounting of Body Equipment

Do not mount any Body Equipment within 8 inches (200mm) of the exhaust pipe outlet to avoid damage from hot exhaust gases. When modifying other chassis systems, maintain clearances shown in Table 2.

| CT11/13 | |
|----------------|---------------------|
| Pipe Material | 409 Stainless Steel |
| Pipe Diameter | 5" |
| Wall Thickness | 0.065" |

Table 1. Tailpipe Extension, Material and Pipe Sizing

| COMPONENT | MINIMUM CLEARANCE, MM (IN.) |
|----------------------------------|-----------------------------|
| Electric Harness | 150 (6.0) |
| Electric Harness (w. heat guard) | 100 (4.0) |
| Mechanical Cable | 50 (2.0) |
| Fuel Tube, Metal | 150 (6.0) |
| Fuel Tube, Rubber or Plastic | 150 (6.0) |
| Brake Tube, Metal | 100 (4.0) |
| Brake Tube, Rubber or Plastic | 100 (4.0) |
| Tire | 100 (4.0) |

Table 2. Minimum Clearances Between Exhaust System Components and Other Chassis Components

EXHAUST

ALLOWABLE BACKPRESSURE TAILPIPE MODIFICATION CALCULATOR — ALL ENGINE TYPES

Input your data into the entry fields below and press enter to determine total modification backpressure.

| EXHAUST CONFIGURATION: VERTICAL – VERTICAL (INPUT VALUES AND PRESS ENTER) | | | | |
|---|-----------------------------|---|------|------|
| a | Qty of 90° elbows added | x | 0.12 | = |
| b | Qty of 60° elbows added | x | 0.11 | = |
| c | Qty of 45° elbows added | x | 0.09 | = |
| d | Qty of 30° elbows added | x | 0.07 | = |
| e | Feet of Straight Pipe added | x | 0.01 | = |
| f | Pipe Exit Pressure | | | 0.87 |

Total Modification backpressure (Add a-f)

Allowable Backpressure Limit

3.6

Is allowable Backpressure Limit **GREATER** than Total Modification Backpressure?

If **YES**, Modifications **MEET** Engine Manufacturer's Guidelines and **CAN** be performed.

If **NO**, Modifications will **NOT MEET** Engine Manufacturer's Guidelines and **CANNOT** be performed.

EXHAUST

ALLOWABLE BACKPRESSURE TAILPIPE MODIFICATION CALCULATOR — ALL ENGINE TYPES

Input your data into the entry fields below and press enter to determine total modification backpressure.

| EXHAUST CONFIGURATION: HORIZONTAL – VERTICAL (INPUT VALUES AND PRESS ENTER) | | | | |
|---|-----------------------------|---|------|------|
| a | Qty of 90° elbows added | x | 0.12 | = |
| b | Qty of 60° elbows added | x | 0.11 | = |
| c | Qty of 45° elbows added | x | 0.09 | = |
| d | Qty of 30° elbows added | x | 0.07 | = |
| e | Feet of Straight Pipe added | x | 0.01 | = |
| f | Pipe Exit Pressure | | | 0.87 |

Total Modification backpressure (Add a-f)

Allowable Backpressure Limit

1.8

Is allowable Backpressure Limit **GREATER** than Total Modification Backpressure?

If **YES**, Modifications **MEET** Engine Manufacturer's Guidelines and **CAN** be performed.

If **NO**, Modifications will **NOT MEET** Engine Manufacturer's Guidelines and **CANNOT** be performed.

EXHAUST

CT11/13 AFTERTREATMENT DIAGRAMS — 0007BDS NOT W/ 0007SCS (EGR ONLY)

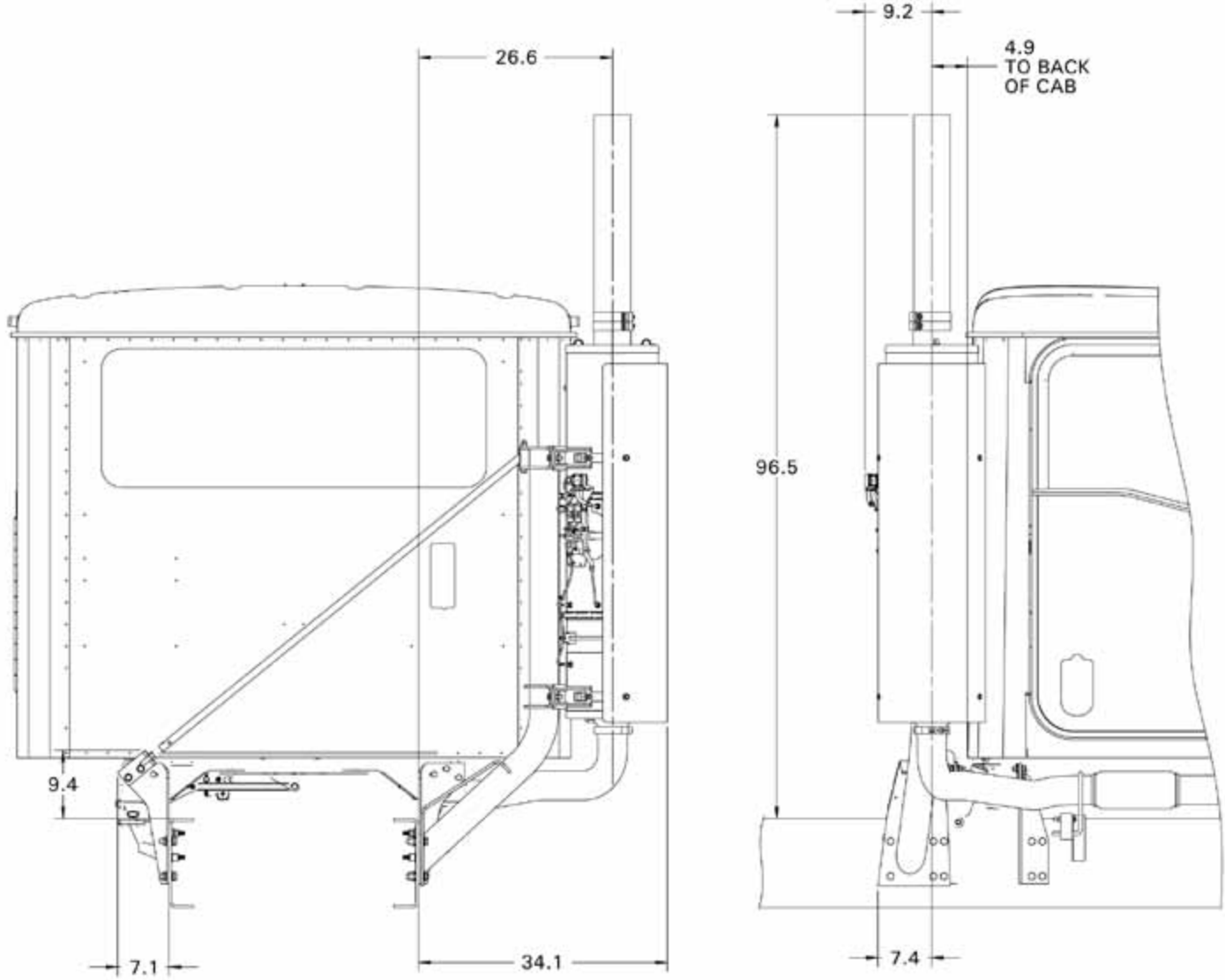

EXHAUST

CT11/13 AFTERTREATMENT DIAGRAMS — 0007BDS WITH 0007SCS (EGR ONLY)

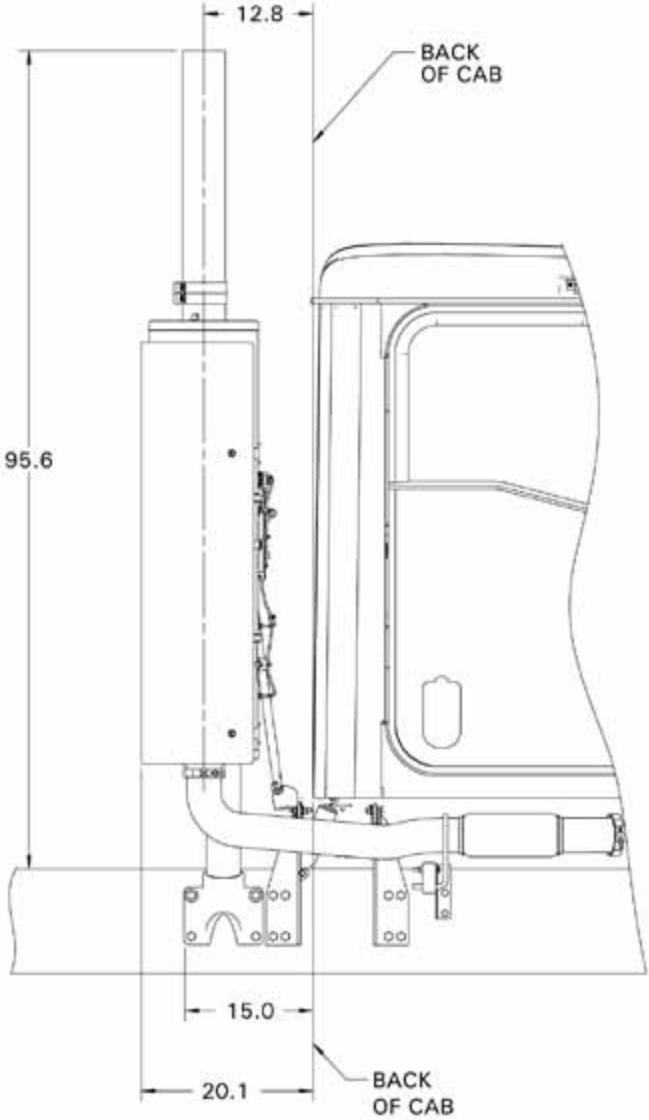
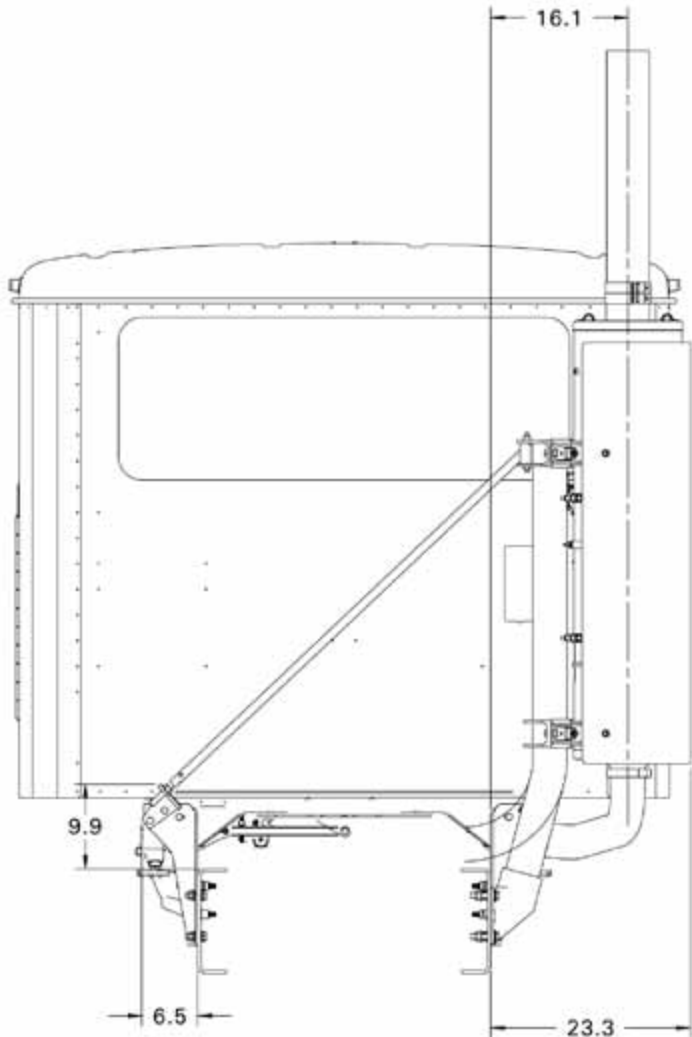

EXHAUST

CT11/13 AFTERTREATMENT DIAGRAMS — 0007BJC (EGR ONLY)

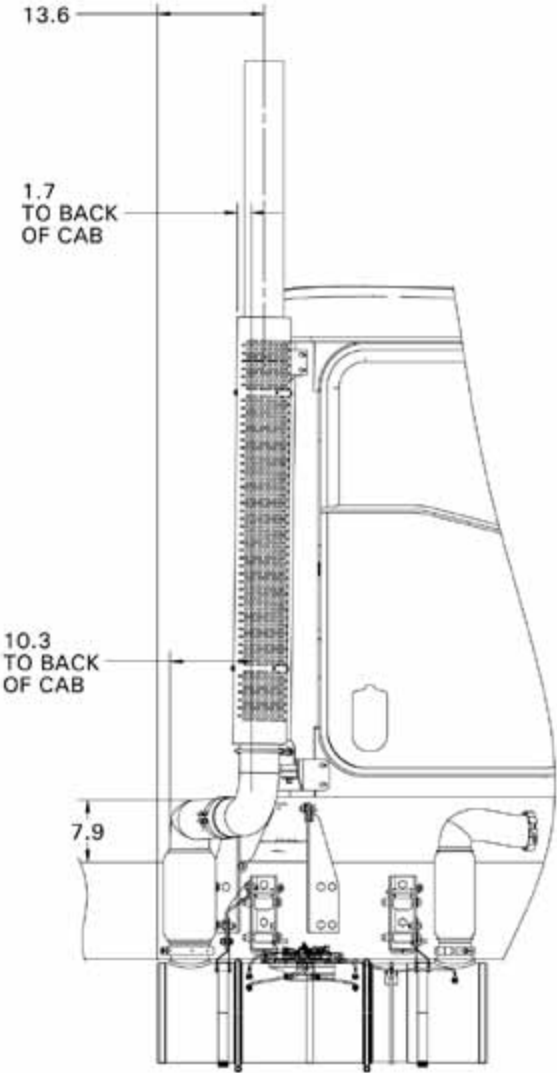
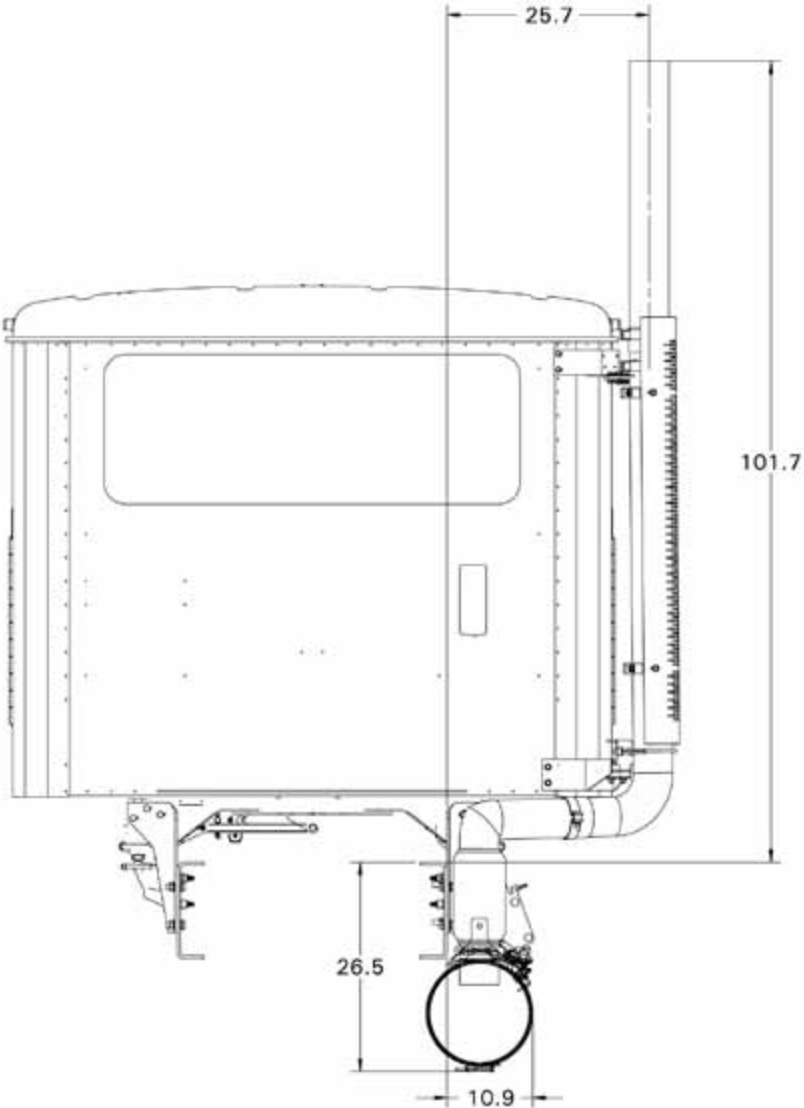

EXHAUST

CT13 AFTERTREATMENT DIAGRAMS — 07BJU (SCR ONLY)

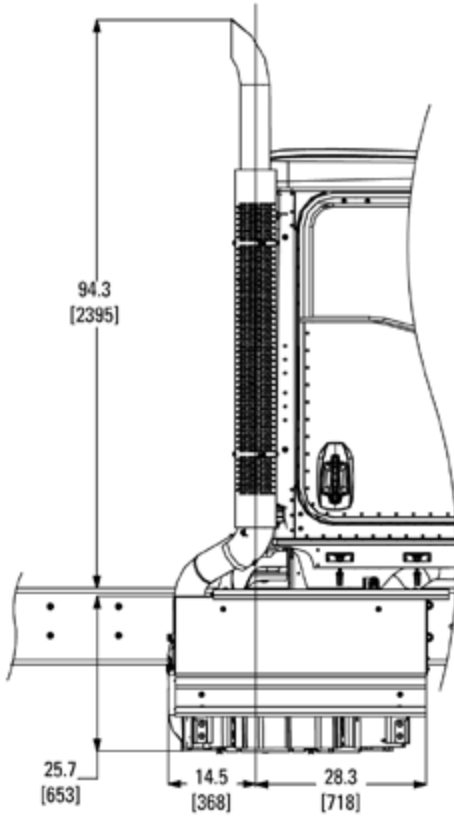
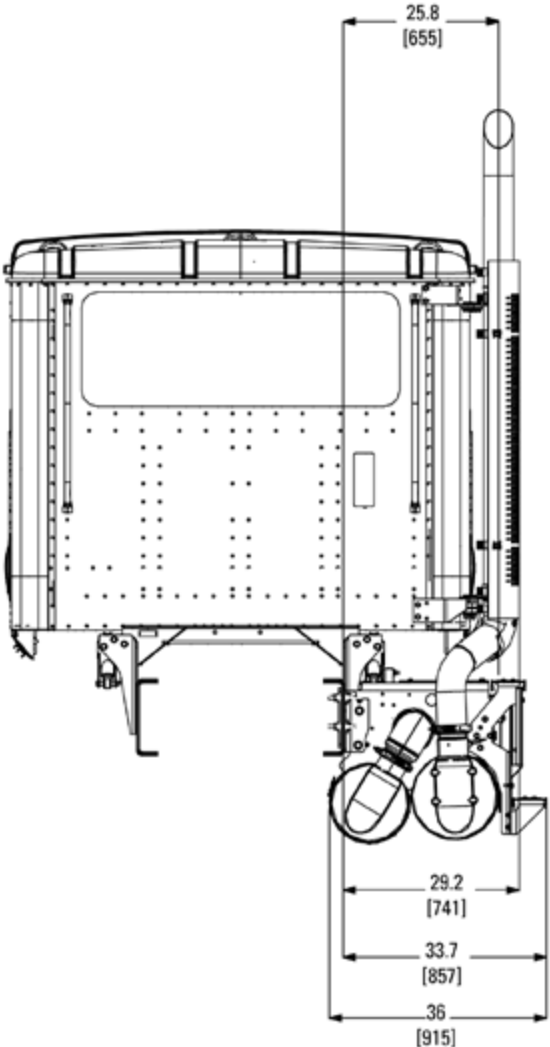

[↶ return to table of contents](#)

EXHAUST

CT 13 AFTERTREATMENT DIAGRAMS — 07DXM (SCR ONLY)

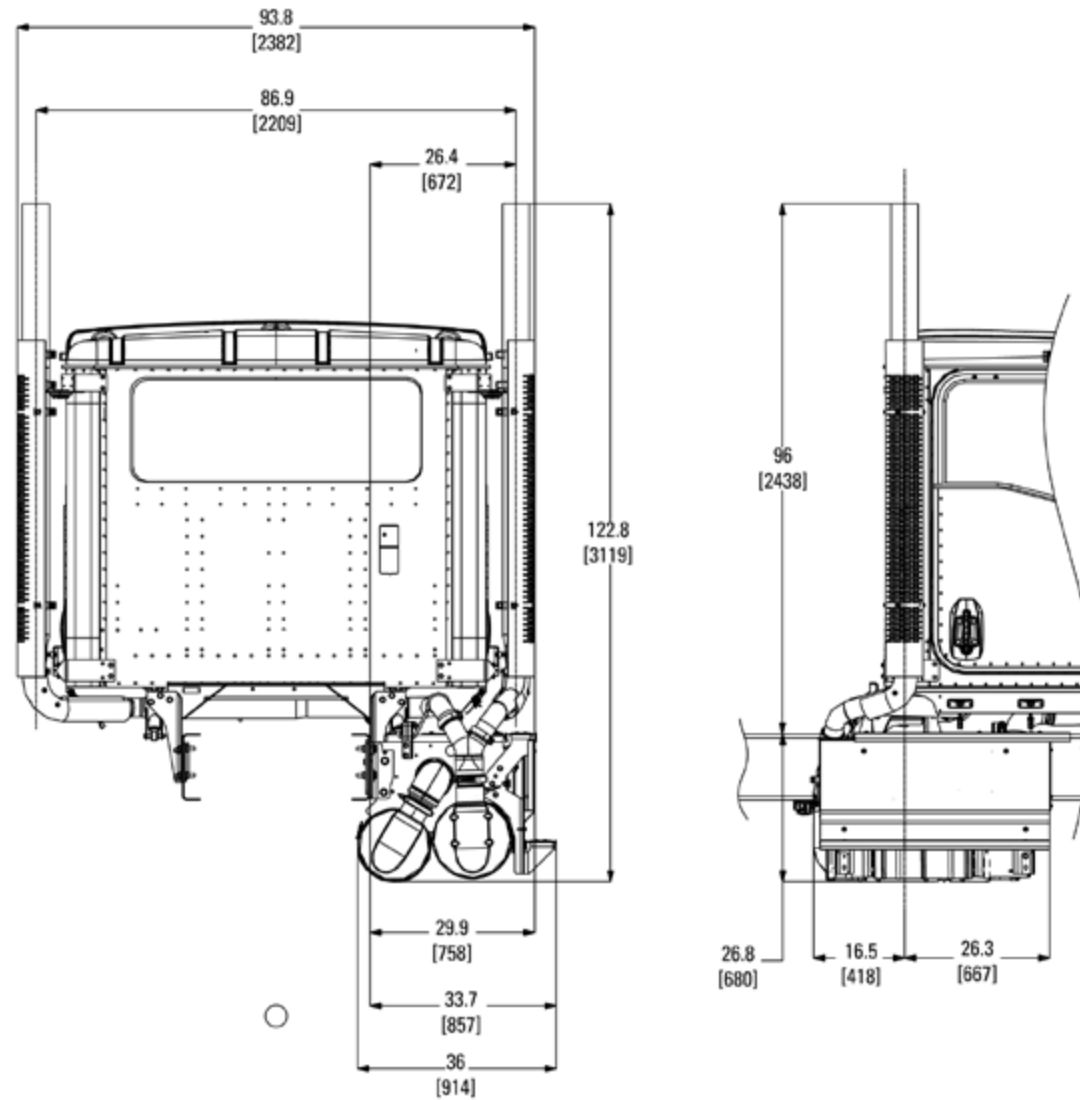

EXHAUST

CT13 AFTERTREATMENT DIAGRAMS — 0007BJX (SCR ONLY)

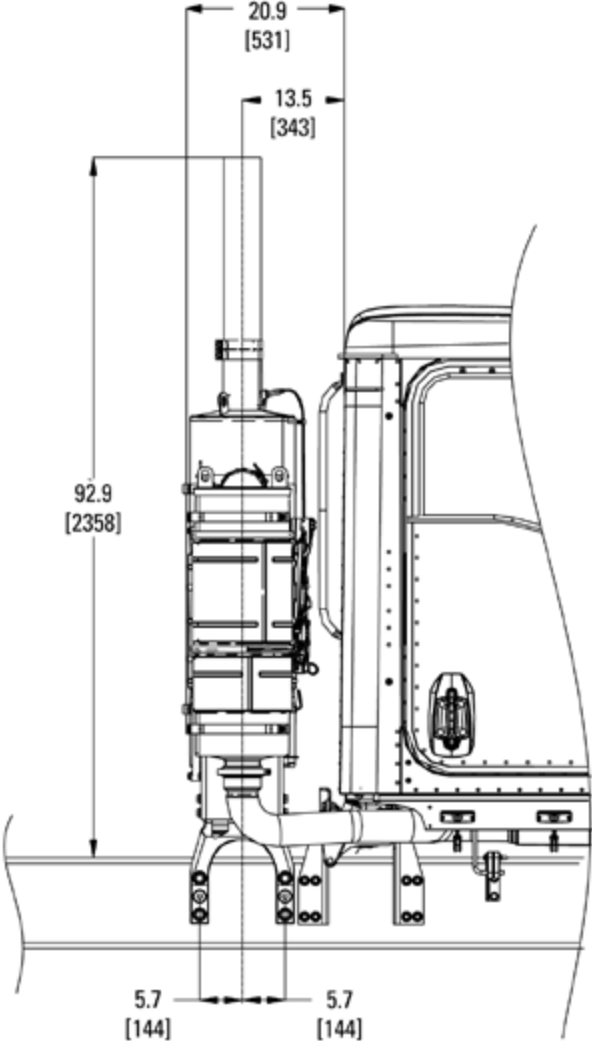
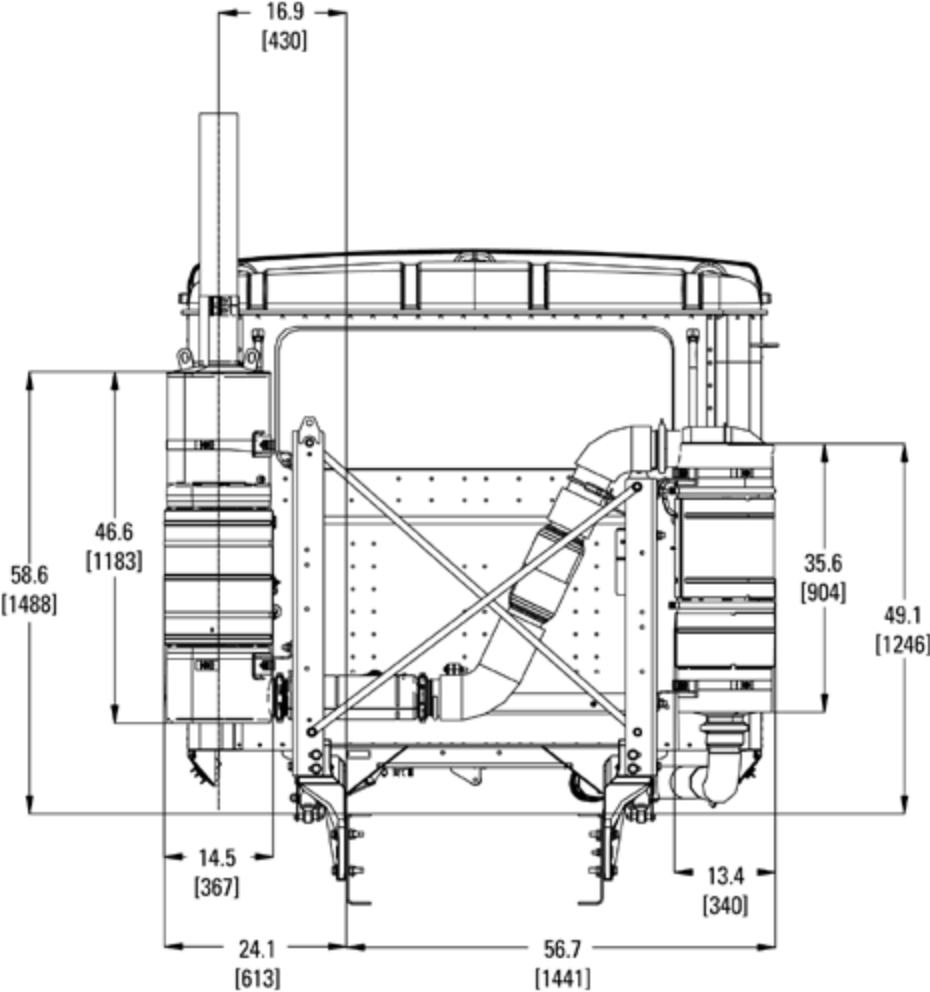

EXHAUST

CT15 AFTERTREATMENT DIAGRAMS — 0007BDS NOT W/ 0007SCS (EGR ONLY)

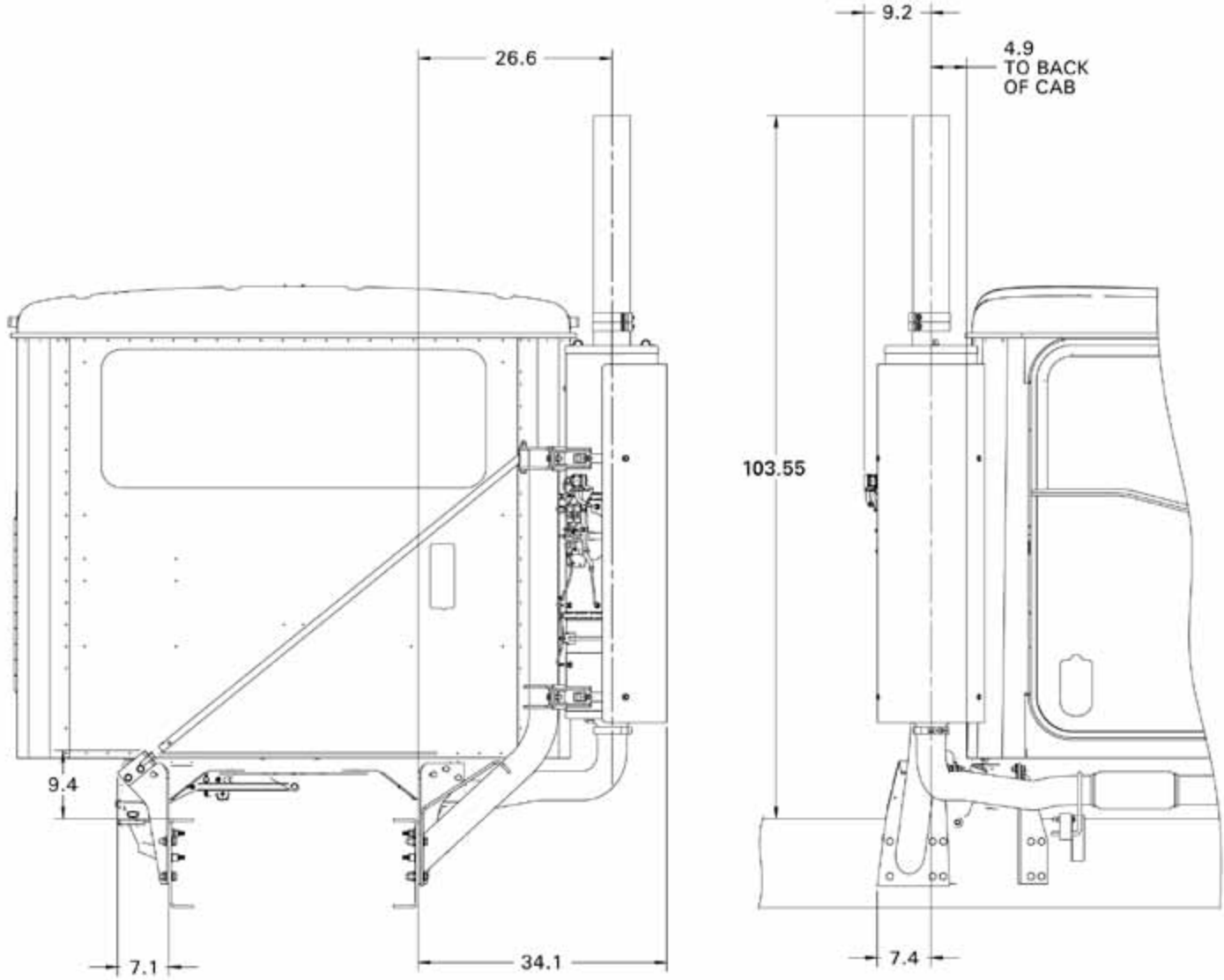

EXHAUST

CT15 AFTERTREATMENT DIAGRAMS — 0007BDS WITH 0007SCS (EGR ONLY)

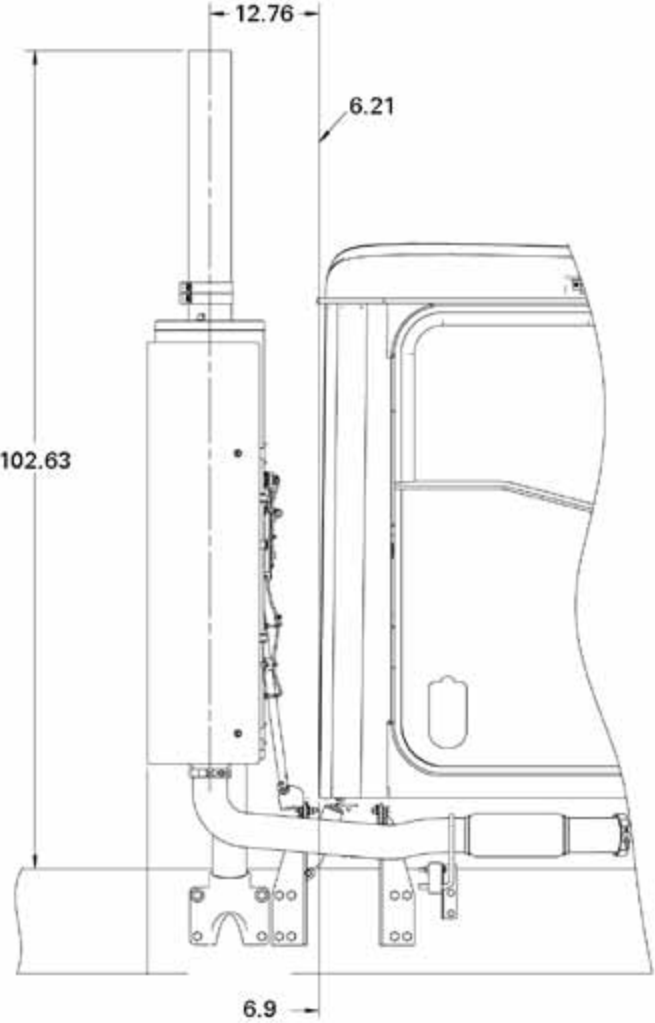
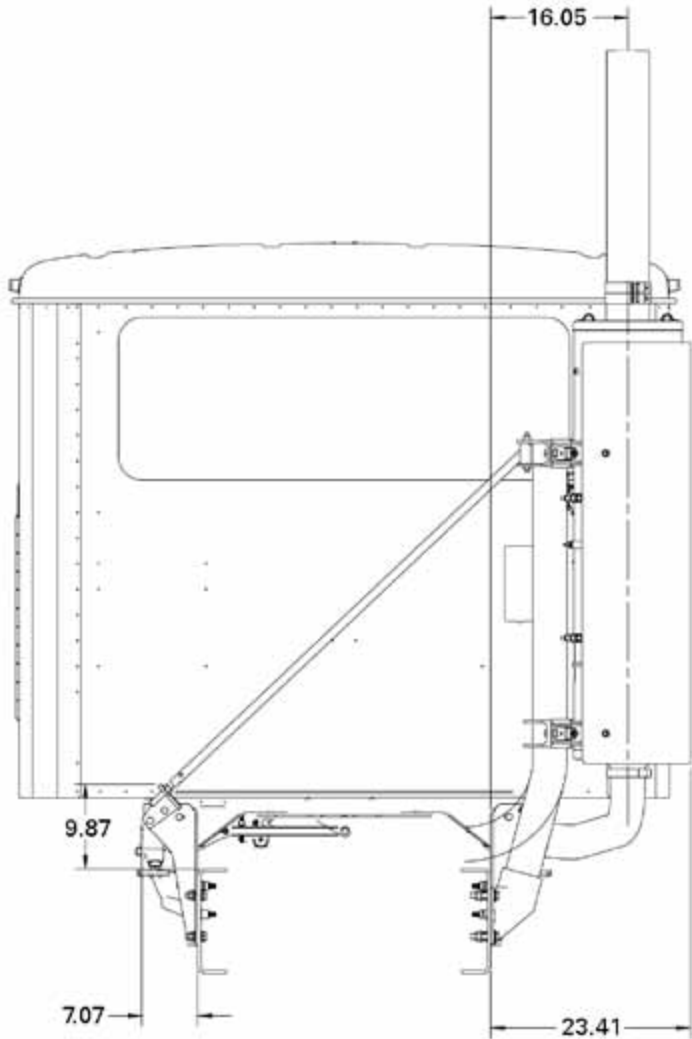

EXHAUST

CT15 AFTERTREATMENT DIAGRAMS — 0007BJC (EGR ONLY)

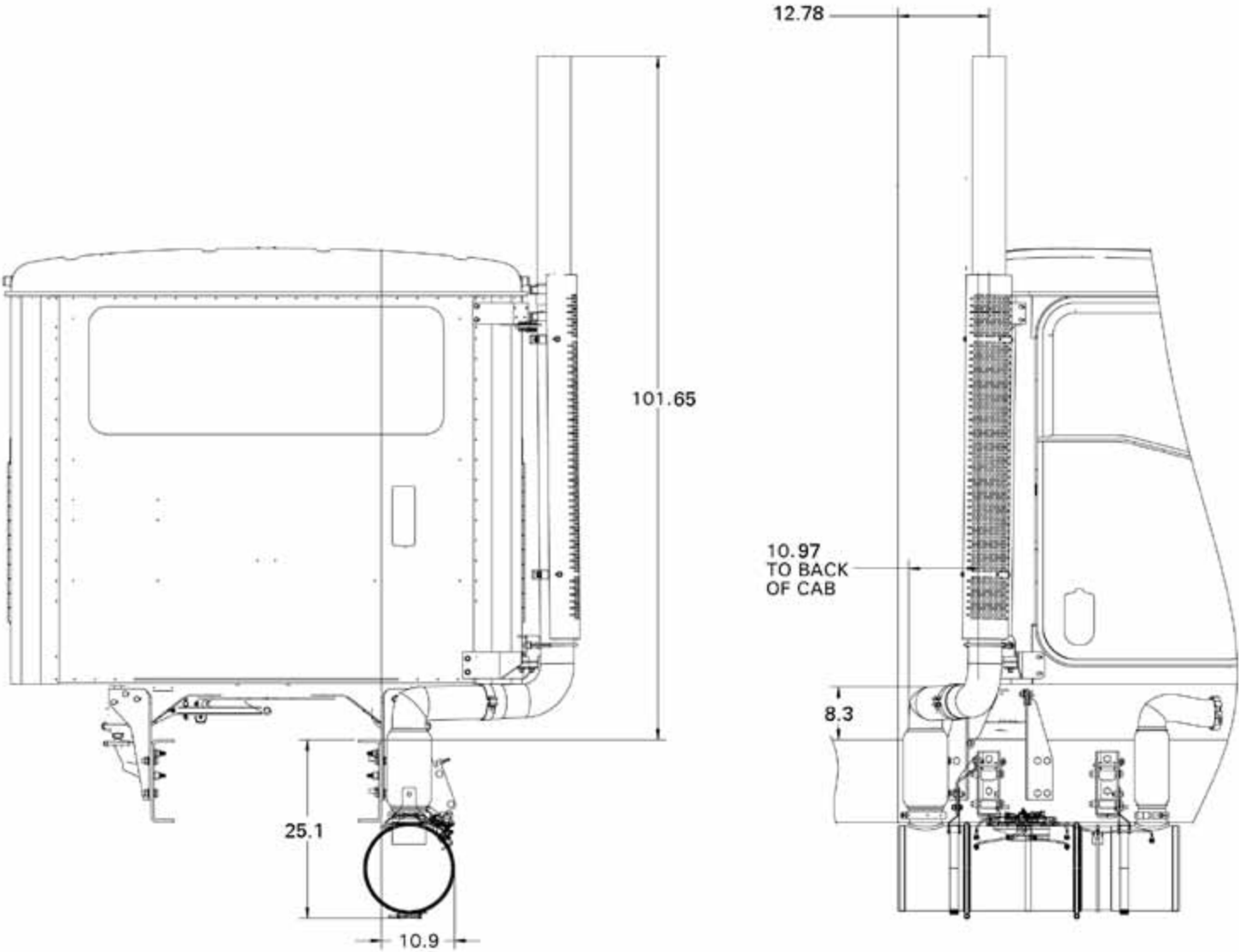

EXHAUST

C15 AFTERTREATMENT DIAGRAMS — 0007DHJ (EGR ONLY)

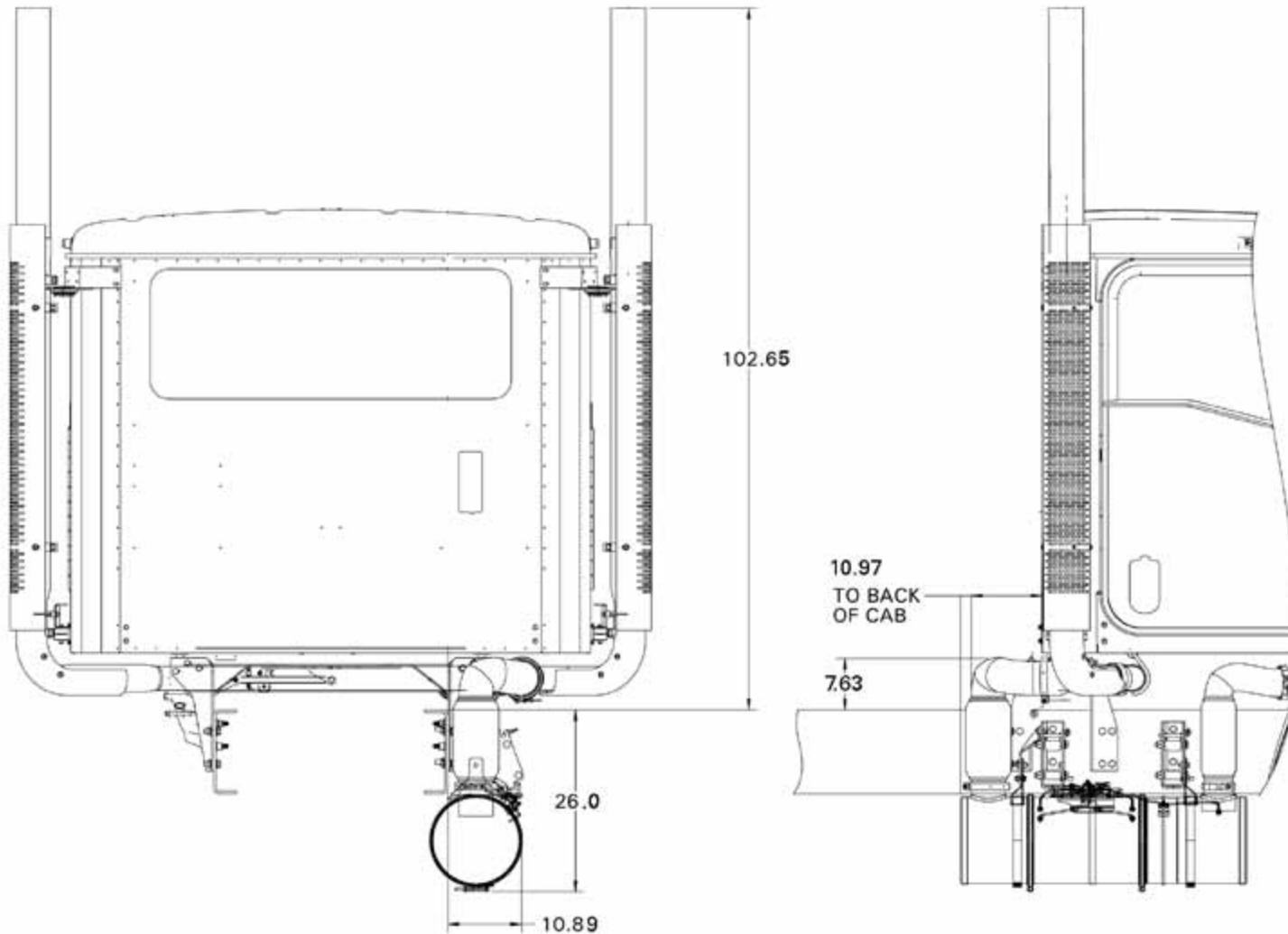

[↶ return to table of contents](#)

FIFTH WHEEL

FIFTH WHEEL HEIGHT CALCULATIONS

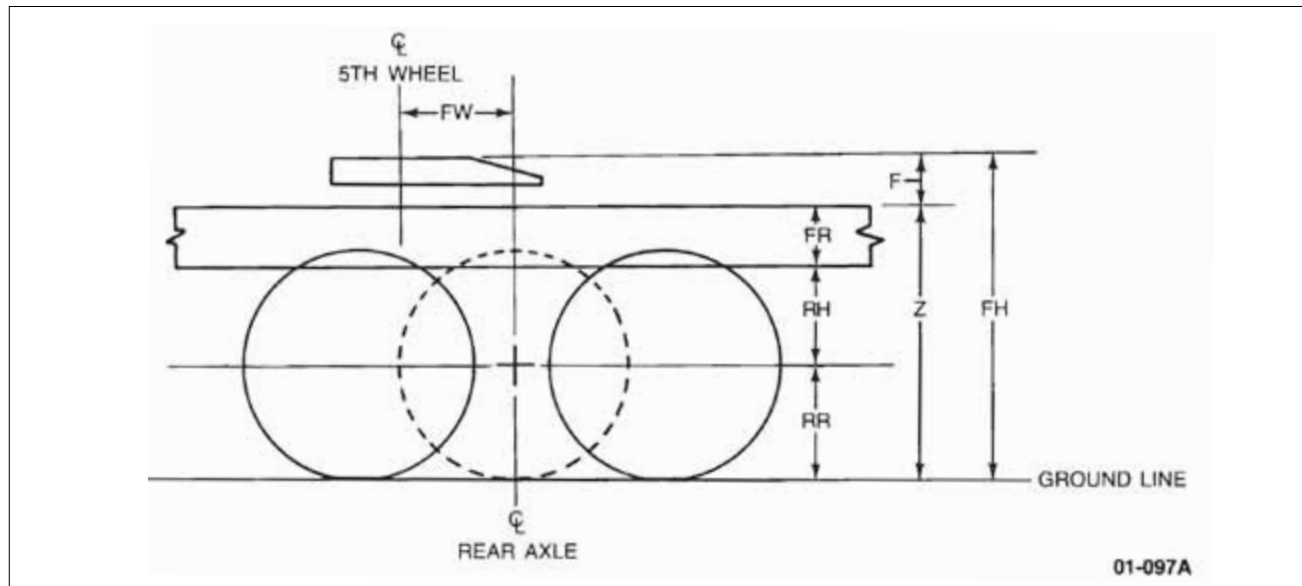

Calculate the fifth wheel height (measured from the ground) using the following formula:

$$FH = Z + F + SP$$

(for unloaded chassis)

| INPUT YOUR DATA INTO THE ENTRY FIELDS BELOW AND PRESS ENTER TO DETERMINE FRAME HEIGHT AND FIFTH WHEEL HEIGHT | | | |
|--|---|--|--|
| FR | = | Frame Rail - Overall Height | |
| RH | = | Ride Height of Rear Suspension | |
| RR | = | No-Load Radius (Half of Overall Diameter) *see next page for details | |
| Z | = | Frame Height (@ centerline of rear axle with an unloaded chassis) | |
| F | = | Distance from top of the frame rails to the top of the fifth wheel | |
| SP | = | Fifth Wheel Spacer Plate (if applicable) **see next page for details | |
| FH | = | Fifth Wheel Height (from ground to top of 5th wheel) - RR + RH + FR + F + SP | |

[↶ return to table of contents](#)

FIFTH WHEEL

FIFTH WHEEL HEIGHT CALCULATIONS

** Add 3/8" on all Fontaine sliding fifth wheels with all HAS air suspensions as well as with 60" and 72" Primaax air suspensions with single frame rails or 1/4" + 1/4" reinforced frame rails.

** Add 5/16" on all Fontaine stationary fifth wheels.

** When using 14698 Hendrickson RT-523 suspensions with single frame rail, Fontaine stationary fifth wheel and fifth wheel locations of 6" or 10" ahead of rear axle centerline, add an additional 1/4".

No spacer plate values need to be added to the fifth wheel height calculation for Holland sliding and stationary fifth wheels.

* For tire Rolling Radius calculate the radius of the "no-load" tire dimensions. This can be found at the tire manufacturers website under "Overall Diameter". Half of the diameter is the radius. Do not use "Static Loaded Radius".

Example 1:

| | | | | |
|-----------|---|--|--------------------------|--------|
| FR | = | Frame Rail - Overall Height | 01CDH | 12.25 |
| RH | = | Ride Height of Rear Suspension | 14UKZ Hendrickson HAS | 9.5 |
| RR | = | No-Load Radius (Half of Overall Diameter) | Michelin XDE M/S 11R22.5 | 20.8 |
| Z | = | Frame Height (@ centerline of rear axle with an unloaded chassis) | | 42.55 |
| F | = | Distance from top of the frame rails to the top of the fifth wheel | 10GCH Fontaine | 7.75 |
| SP | = | Fifth Wheel Spacer Plate (if applicable) | 3/8" Plate | .375 |
| FH | = | Fifth Wheel Height (from ground to top of 5th wheel) - RR + RH + FR + F + SP | | 50.675 |

Example 2:

| | | | | |
|-----------|---|--|------------------------------|-------|
| FR | = | Frame Rail - Overall Height | 01CDH | 12.25 |
| RH | = | Ride Height of Rear Suspension | 14UNX Primaax | 9 |
| RR | = | No-Load Radius (Half of Overall Diameter) | Michelin XDE M/S 275/80R22.5 | 20.25 |
| Z | = | Frame Height (@ centerline of rear axle with an unloaded chassis) | | 41.5 |
| F | = | Distance from top of the frame rails to the top of the fifth wheel | 10GCG Fontaine | 6.75 |
| SP | = | Fifth Wheel Spacer Plate (if applicable) | None | .0 |
| FH | = | Fifth Wheel Height (from ground to top of 5th wheel) - RR + RH + FR + F + SP | | 48.25 |

↪ return to table of contents

FIFTH WHEEL

FIFTH WHEEL MOUNTING INFORMATION

Outlined below are recommended guidelines for installation of fifth wheels on vehicles. The more common combinations of frame, suspension, fifth wheel and fifth wheel offset dimensions are covered in this section. For mounting applications not covered in this section, refer to the fifth wheel manufacturer for installation instructions.

NOTE: It must be recognized that the ultimate responsibility for the durability and security of the fifth wheel mounting lies with the installer/user. Therefore, the installer/user is cautioned to consult the fifth wheel manufacturer's installation recommendations and whatever legal requirements and regulations are applicable.

It is also the responsibility of the installer/user to make sure that the vehicle frame is adequate for the fifth wheel offset location from the centerline of the single rear axle (4 x 2 vehicles) or tandem rear axle (6 x 4 vehicles).

Precautions

As with any after-market modification, care must be taken when installing a fifth wheel. The following precautions must be taken when installing a fifth wheel.

CAUTION: Do not weld or drill the top or bottom flanges of the vehicle frame. Welding or drilling the flanges will severely weaken the frame.

Do not drill frame sidemember(s) other than as specified in "FRAMES - Drilling or Notching".

Fifth wheel attachments must not be welded directly to the sidemember.

Maintenance

The fifth wheel should be properly maintained to ensure proper operation. The following is a general guideline for maintaining the fifth wheel.

- 1) Always keep the track of sliding fifth wheels as clean as possible. Periodically lubricate all moving parts of fixed and sliding fifth wheels.
- 2) Inspect fifth wheel for proper operation.
- 3) Inspect fifth wheel for damaged or missing parts. Replace as required.
- 4) Be sure all bolts retaining fifth wheel assembly to vehicle frame are properly tightened.

FIFTH WHEEL

FIFTH WHEEL MOUNTING INFORMATION

Replacement

Remove

- 1) Remove all bolts retaining fifth wheel to mounting angle.
- 2) Remove fifth wheel assembly from vehicle frame.

Install

- 1) Position fifth wheel assembly on mounting angles. Be sure to properly align bolt holes in angle bracket to fifth wheel.
- 2) Install all retaining bolts and tighten to the specified torque.

Mounting

Mounting Angles

The use of mounting angles to mount the fifth wheel to the vehicle frame is recommended. Mounting angles provide for more direct transfer of the load to the frame sidemembers for better stress distribution. Some fifth wheels incorporate integral mounting angles as part of the fifth wheel assembly.

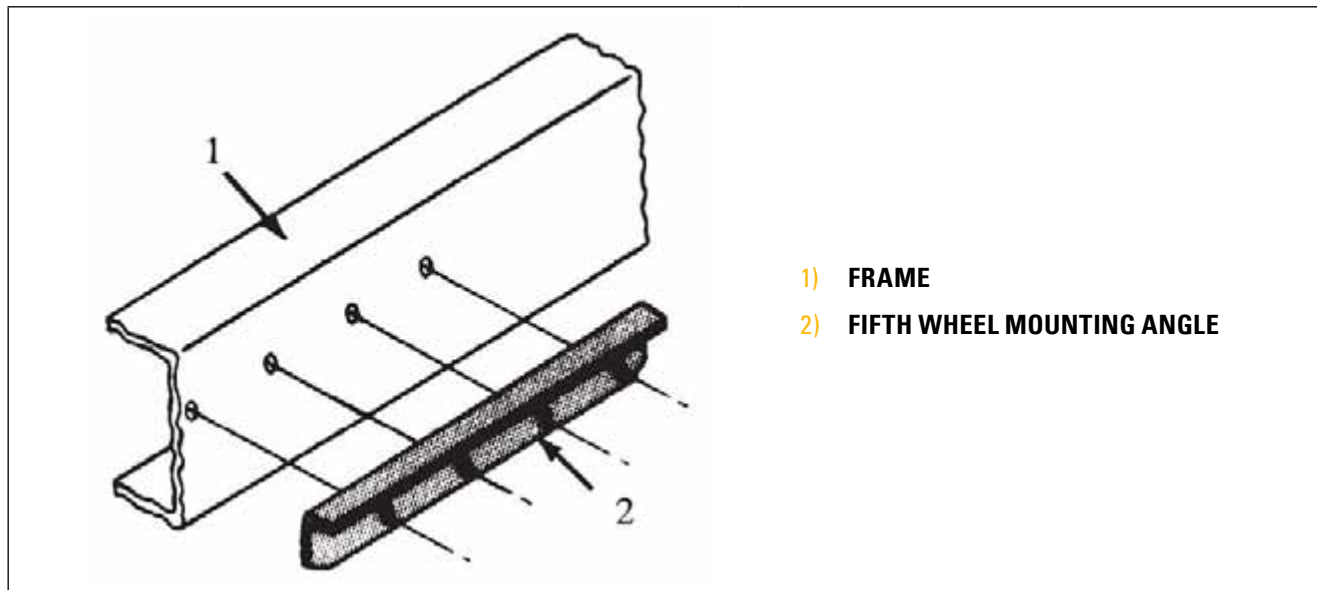

Figure 1.1 Fifth Wheel Mounting Angle

FIFTH WHEEL

FIFTH WHEEL MOUNTING INFORMATION

Mounting angles must be made of steel conforming to SAE J410, grade 965X, 0.312 inch (8 mm) thick; or ASTM A572, grade 50, 0.38 inch (9.6 mm) thick; or conform to fifth wheel manufacturer's specifications that cover your particular circumstances. It is permissible to cut mounting angles to provide clearance for spring mounting brackets, etc. Cutouts in the vertical flanges of the mounting angles should be minimized in number and size. Cutouts must be rounded at the inside corners. Inner radii of cutouts should be 0.5 inch (13 mm) minimum; 0.75 inch (19.0 mm) radii are preferred. To make cutouts in mounting angles, drill holes at radii of cutouts. Then, saw or torch cut to remove remaining material. Cut edges should be ground smooth.

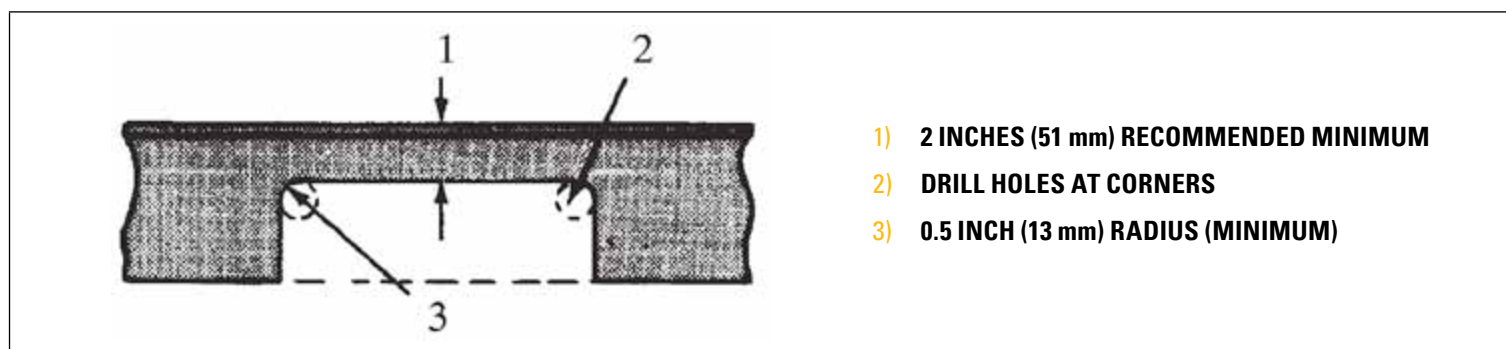

Figure 1.2 Mounting Angle Cutout

Some vehicles have spring mounting brackets designed to permit installation of fifth wheel mounting angle between the spring bracket and vehicle frame. Remove factory installed spacers to install mounting angles. Re-tighten bolts as specified in the Torque Chart.

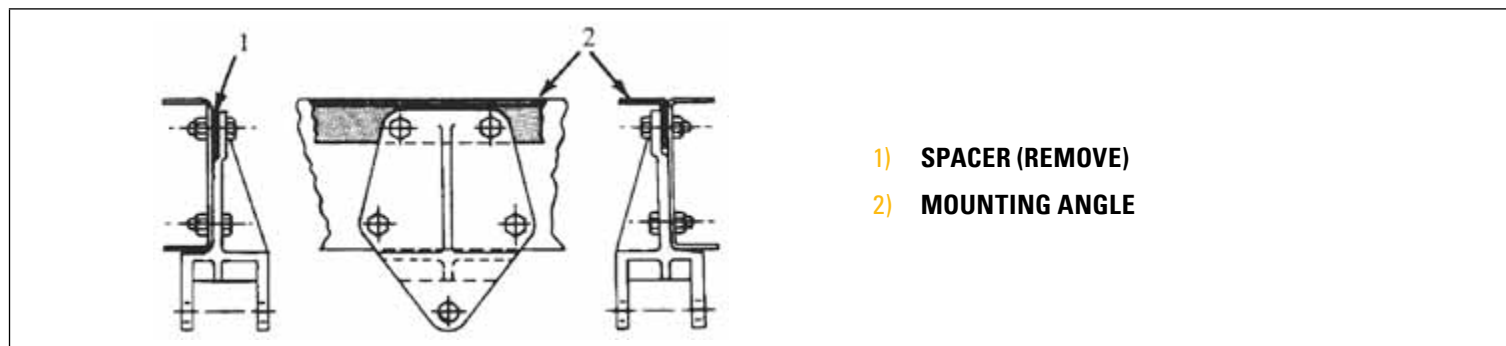

Figure 1.3 Mounting Angle Position

Mounting angles should be secured to frame sidemembers using quantity and spacing of bolts as determined by following the guidelines provided in this section.

[↶ return to table of contents](#)

FIFTH WHEEL

FIFTH WHEEL MOUNTING INFORMATION

Mounting Bolts

The use of phosphate and oil coated SAE Grade 8 flanged fasteners is recommended. Where flanged fasteners are not available, the use of hardened steel flat washers under bolt head and nut is recommended. Where locations of mounting bolts are limited by cutouts, the new bolt pattern should conform as closely as possible to recommendations in terms of number of fasteners, edge distances and spacings. For horizontal bolt applications (mounting angle-to-frame sidemember), use 5/8-inch (16 mm) diameter bolts. Tighten nuts as specified in the "Bolt Torque Chart (Phosphate and Oil Coated)" (Table 1.1).

For vertical bolt applications (fifth wheel-to-mounting angle, fifth wheel-to-support plate, fifth wheel-to-cross tie, cross tie-to-mounting angle), use 3/4-inch (19 mm) diameter bolts. These bolts must be flanged head or hex head with hardened flat washers. Tighten nuts as specified in "Bolt Torque Chart (Phosphate and Oil Coated)" (Table 1.1).

NOTE: Some sliding and fixed fifth wheels are designed to use 5/8-inch (16 mm) diameter vertical bolts. These are acceptable where specified by design.

Care must be taken to prevent fretting (chafing) damage to frame top flange by sharp edges on fifth wheel mounting parts. Figure 1.5 illustrates methods of preventing fretting (chafing) damage at leading and trailing edges. These methods include:

- 1) Chamfering the edges of fifth wheel mounting parts contacting frame top flange.
- 2) Use of a "flex-lip" to gradually diminish contact forces.

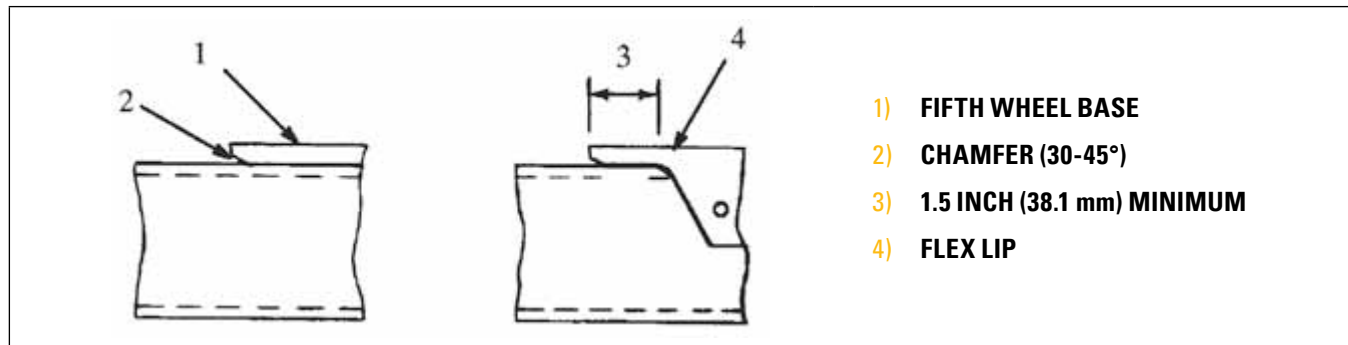

Figure 1.4 Methods of Preventing Fretting Damage

Fifth wheel and mounting parts should be positioned on the vehicle frame to provide maximum contact between the parts which transfer the vertical load onto the upper flange of the frame. Clamp to assure contact before tightening bolts.

FIFTH WHEEL

FIFTH WHEEL MOUNTING INFORMATION

Fixed (Non-Sliding) Fifth Wheels

Typical installations of fixed (non-sliding) fifth wheels are illustrated in Figure 1.6, Figure 1.7, Figure 1.8, Figure 1.9, Figure 1.10, and Figure 1.11. Mounting angles should be secured to frame sidemembers with a minimum of five bolts per side with bolt spacing as shown in Figure 1.6. Recommended fixed fifth wheel mounting dimension limits are shown in Figure 1.6. These limits are as follows:

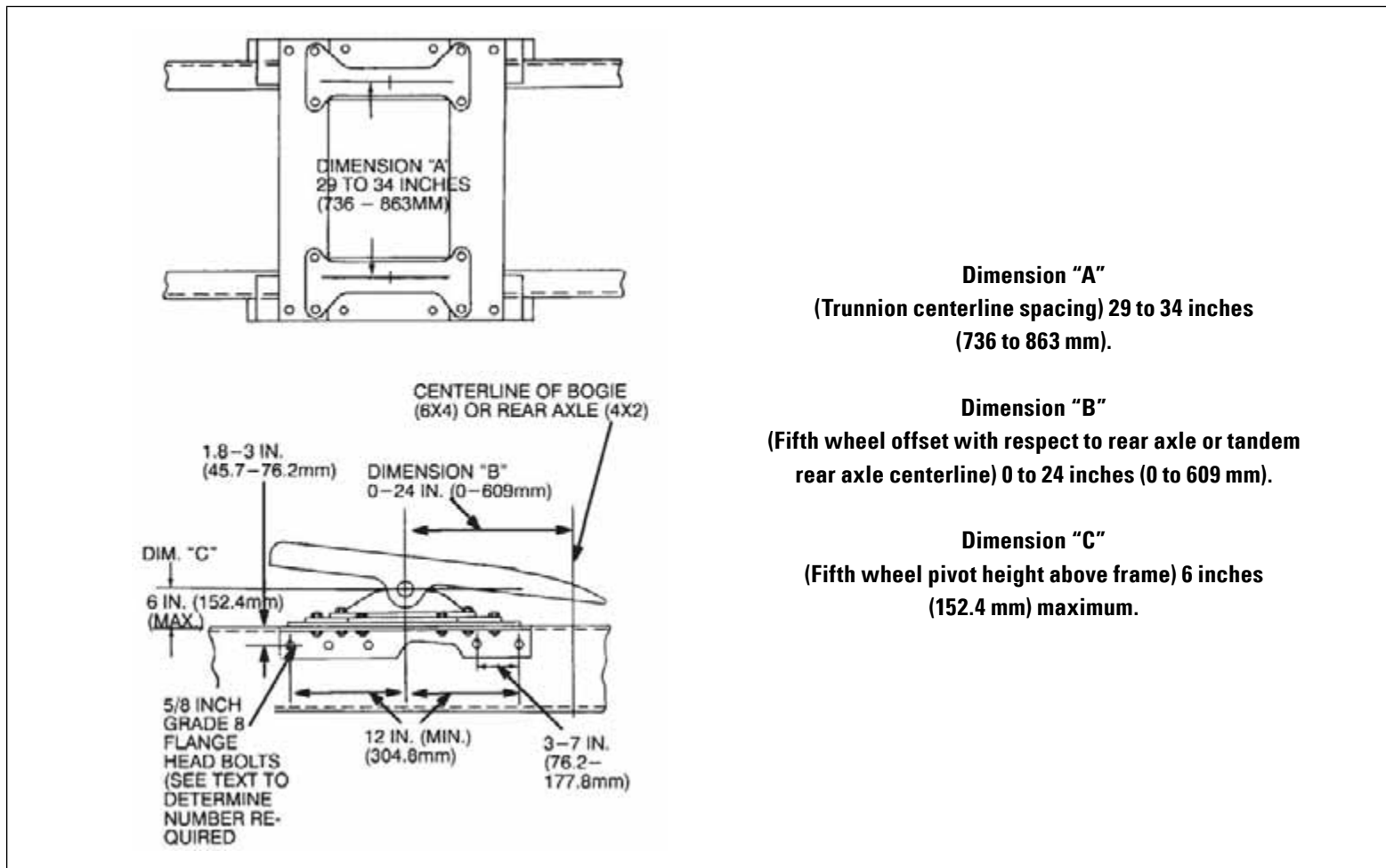

Dimension "A"

(Trunnion centerline spacing) 29 to 34 inches
(736 to 863 mm).

Dimension "B"

(Fifth wheel offset with respect to rear axle or tandem
rear axle centerline) 0 to 24 inches (0 to 609 mm).

Dimension "C"

(Fifth wheel pivot height above frame) 6 inches
(152.4 mm) maximum.

Figure 1.6 Fixed Fifth Wheel Mounting Dimension Limits (Typical)

FIFTH WHEEL

FIFTH WHEEL MOUNTING INFORMATION

Be sure to refer to the segments in this section for mounting angle and cutout information, bolt sizes and torque specifications and corrosion protection on aluminum frames.

CAUTION: Failure to follow the recommended procedures in this section may result in damage to the vehicle frame and possible injury to the operator.

For vehicle frame assemblies without bogie gussets or "C" channel frame reinforcements, install a set of flat cross ties as shown in Figure 1.7 and Figure 1.8.

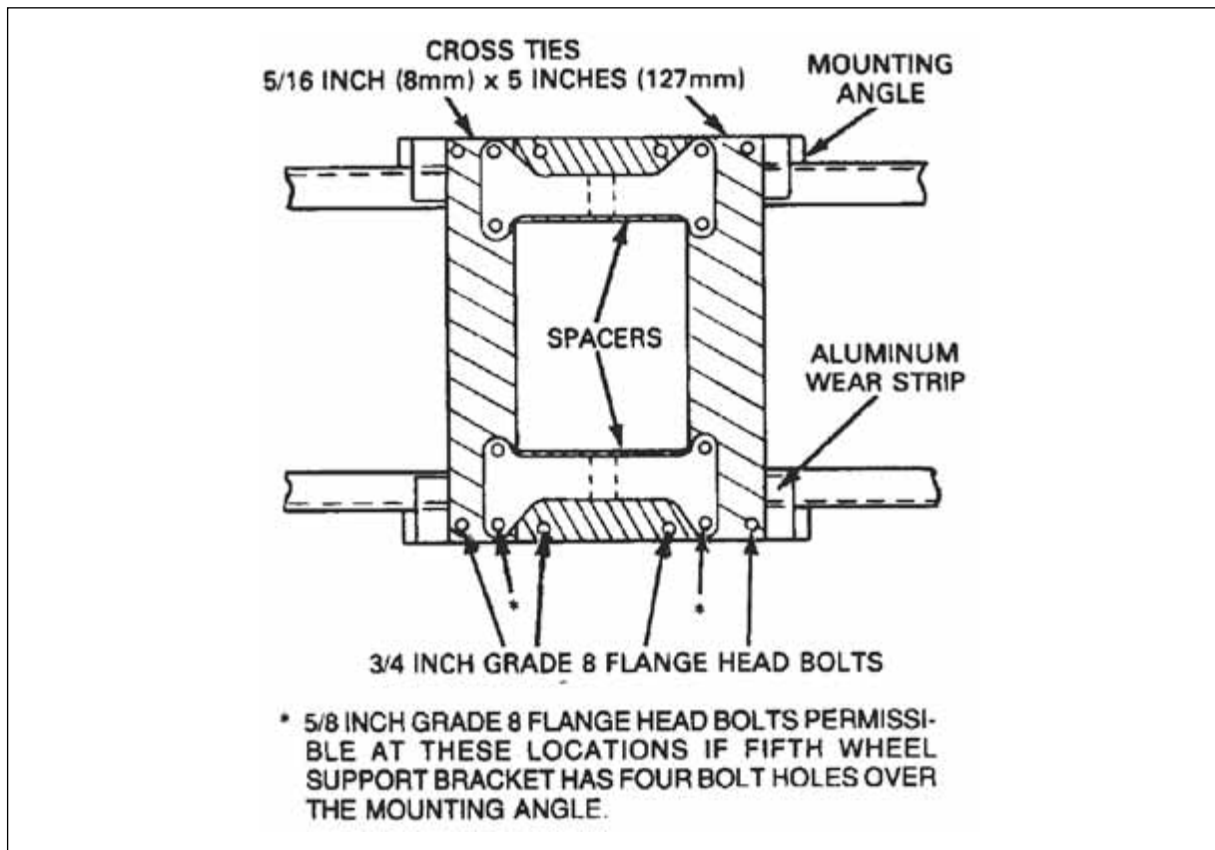

Figure 1.7 Cross Tie Installation (Typical)

FIFTH WHEEL

FIFTH WHEEL MOUNTING INFORMATION

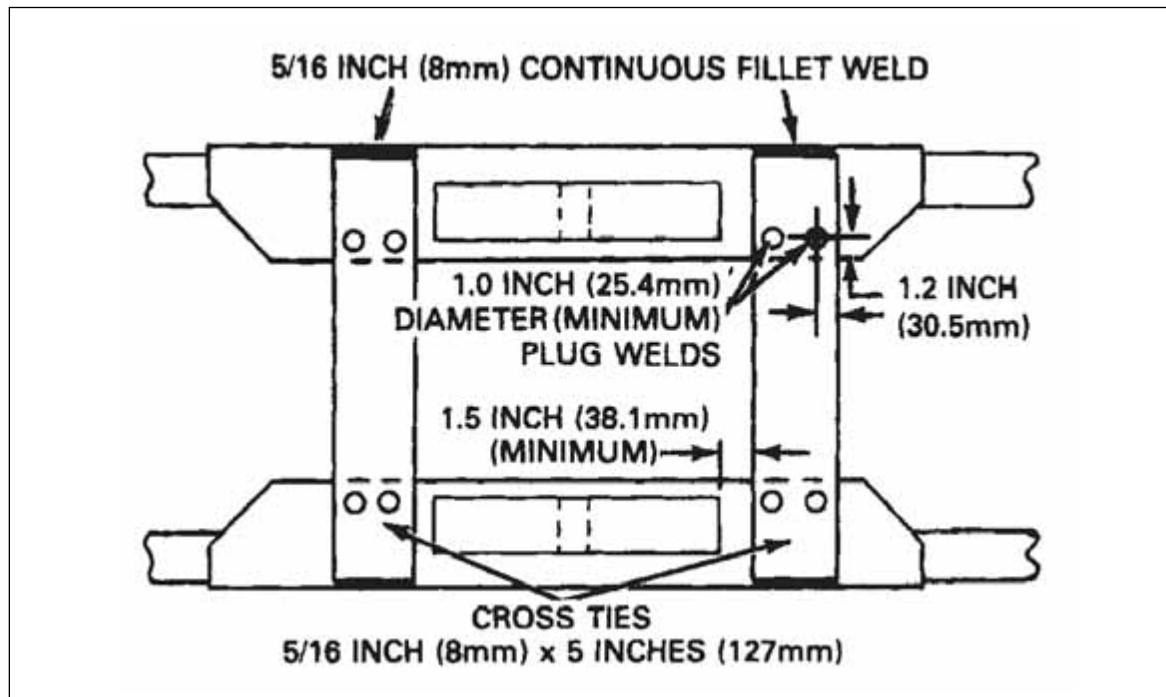

Figure 1.8 Cross Tie Welding (Typical)

For bolted base type fifth wheels, bolt the cross ties and spacers as shown in Figure 1.7. For fifth wheels with integral mounting angle, weld the cross ties as shown in Figure 1.8.

Cross ties should be a minimum of 0.31 inch (8.0 mm) thick x 5 inches (127 mm) wide. Recommended material is 0.31 inch (8.0 mm) thick HSLA 80,000 PSI yield material (SAE 980X).

For bolted base type fifth wheels, a single flat plate or a corrugated plate can be used instead of cross ties. The flat plate should have the bolt pattern shown in Figure 1.9 (top view). The corrugated plate should be installed as shown in Figure 1.9.

For vehicle frame assemblies which have bogie gussets (such as a typical Hendrickson suspension) many fifth wheel installations may be made without cross ties as shown in Figure 1.10 and Figure 1.11. Cross ties may be required in some cases, as indicated.

FIFTH WHEEL

FIFTH WHEEL MOUNTING INFORMATION

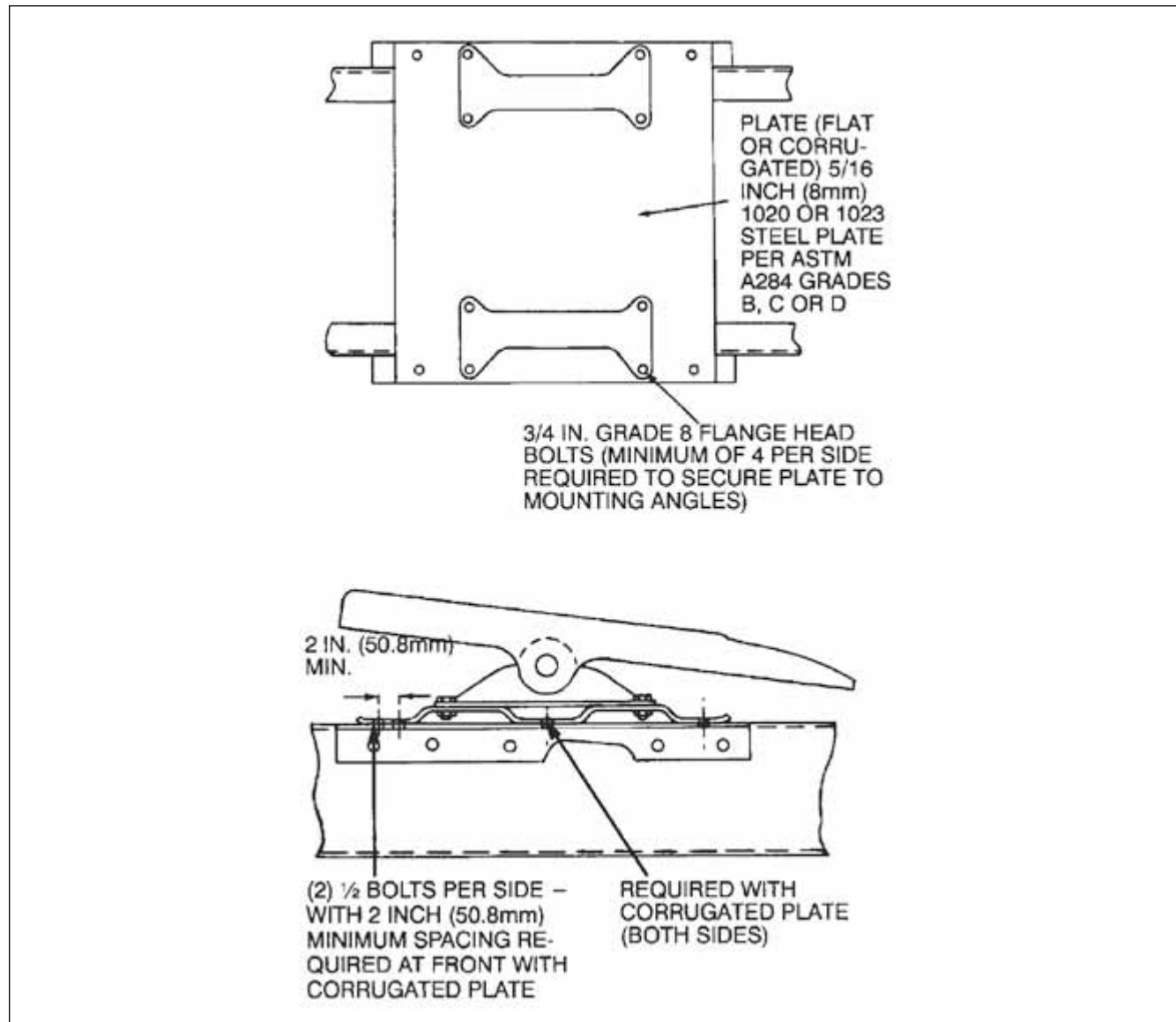

Figure 1.9 Plate Installation (Typical)

FIFTH WHEEL

FIFTH WHEEL MOUNTING INFORMATION

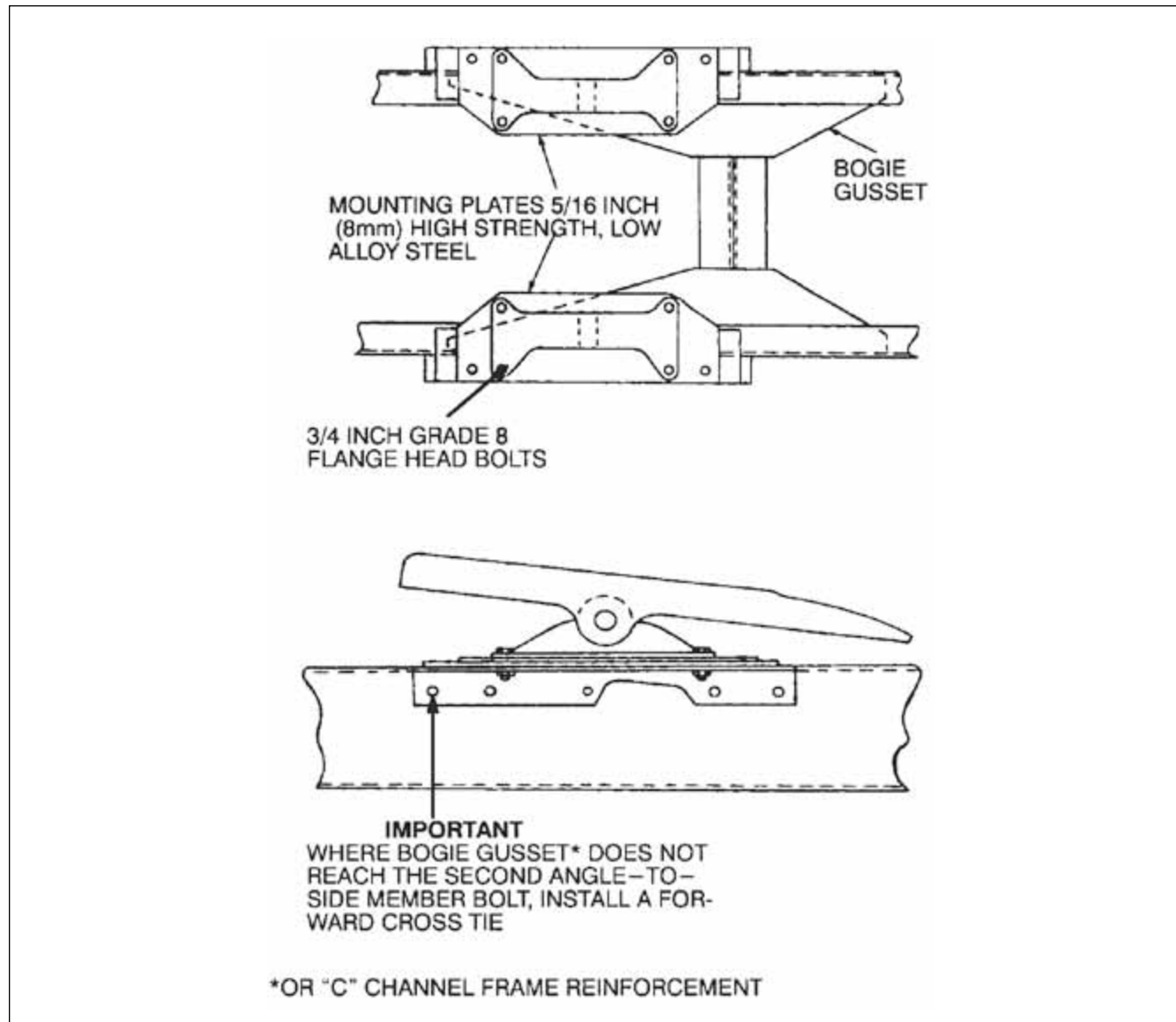

Figure 1.10 Fifth Wheel Installation Without Cross Ties (Typical)

FIFTH WHEEL

FIFTH WHEEL MOUNTING INFORMATION

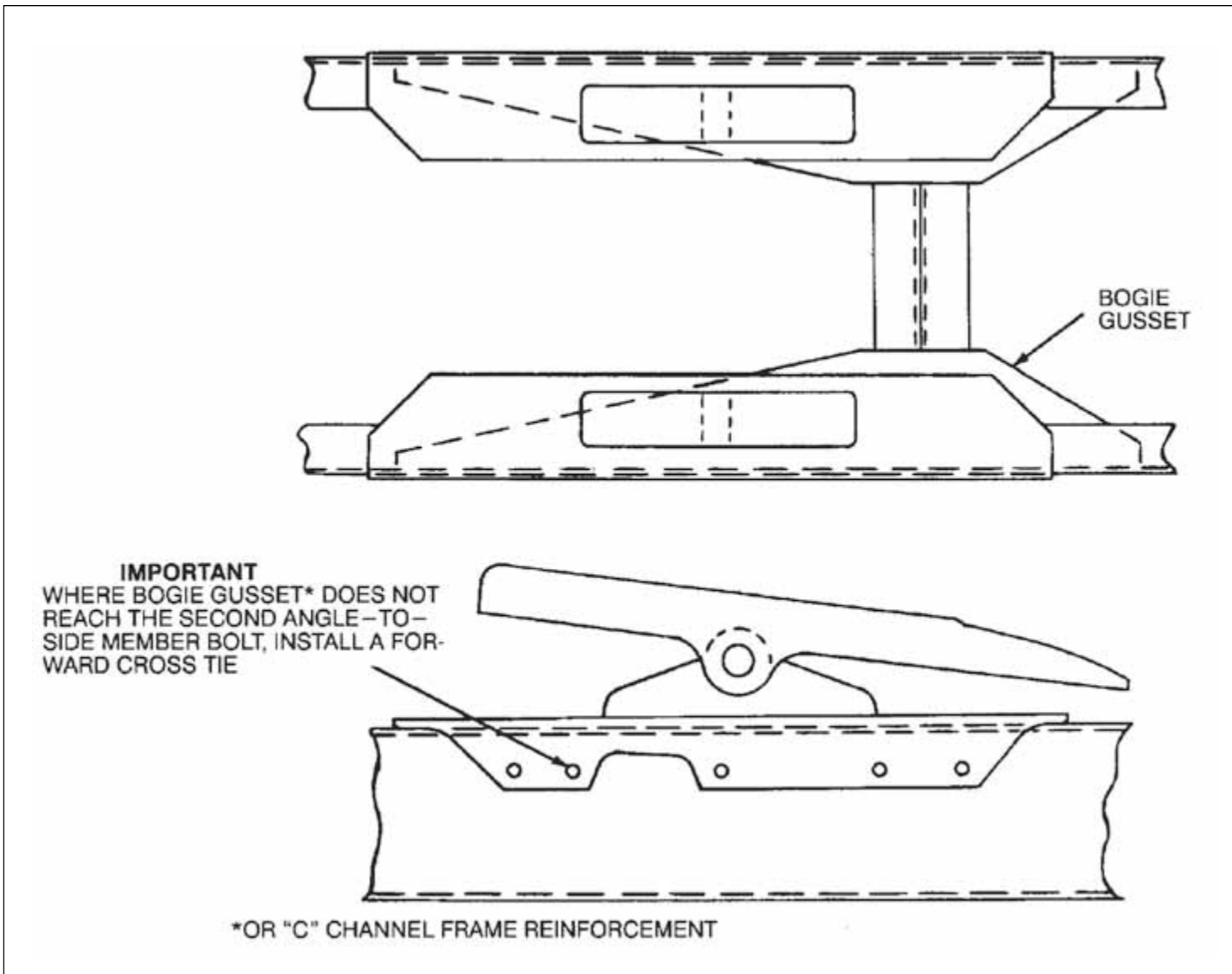

Figure 1.11 Fifth Wheel Installation Without Cross Ties (Typical)

FIFTH WHEEL

FIFTH WHEEL MOUNTING INFORMATION

Sliding Fifth Wheels

These guidelines apply to sliding fifth wheel assemblies where the rails or tracks are tied together on a mounting plate or with cross ties. A typical installation of a sliding fifth wheel is illustrated in Figure 1.12.

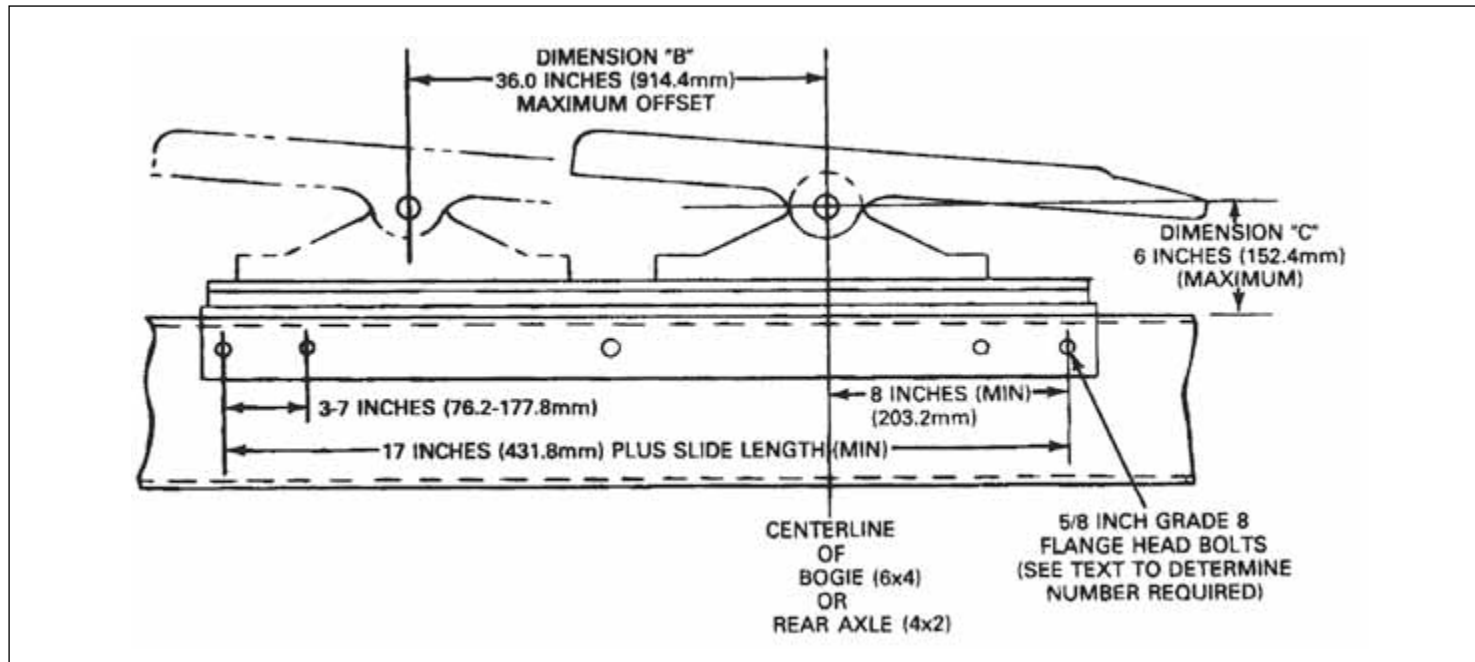

Figure 1.12 Sliding Fifth Wheel Installation (Typical)

Mounting angles should be secured to frame sidemembers with bolts, the minimum number of which are to be determined by dividing the distance between the front and rear bolt holes, as shown in Figure 1.12, by 7.0 inches (177.8 mm) and adding 1. Recommended sliding fifth wheel mounting dimension limits are as follows:

- » **Dimension "B" (Fifth wheel offset with respect to bogie centerline) 0 to 36 inches (0 to 914 mm) maximum.**
- » **Dimension "C" (Fifth wheel pivot height above frame) 6.0 inches (152.4 mm) maximum.**

Sliding fifth wheels, because of their length and construction techniques, are prone to warping and misalignment. This along with vehicle frame variations makes it necessary to check and correct for proper fit where needed.

FIFTH WHEEL

FIFTH WHEEL MOUNTING INFORMATION

Torque

| BOLT SIZE (TYPE 8) | SPECIFIED TORQUE | | | |
|--------------------|------------------|---------|----------|---------|
| | FLANGE HEAD | | HEX HEAD | |
| | FT-LB. | N-M | FT-LB. | N-M |
| 5/8 | 200-240 | 271-325 | 145-175 | 197-237 |
| 3/4 | 300-370 | 406-502 | 250-300 | 339-406 |

Bolt Torque Chart (Phosphate and Oil Coated)

ENGINE

ENGINE LOCATION

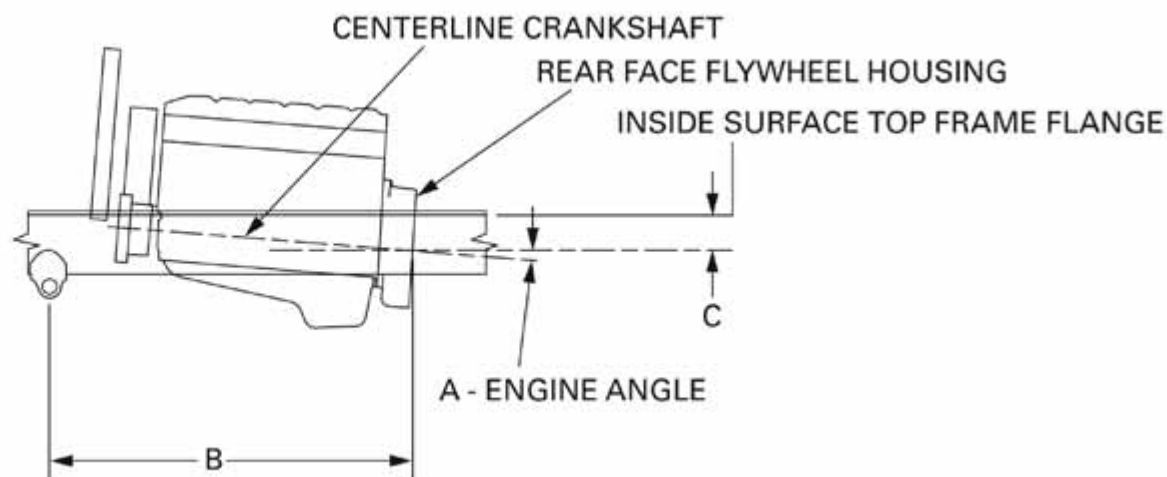
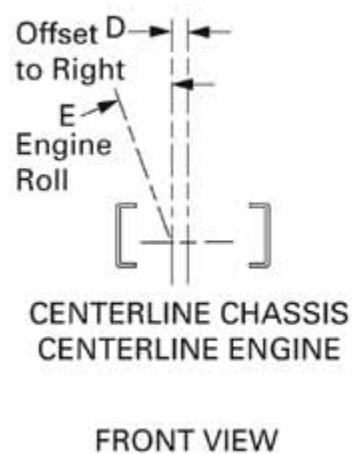

| ENGINE | MODEL | A | | B | | C | | D | | E | |
|------------|---------------------|----------|----------|--------------------|--------------------|--------------------|--------------------|-------------------|-------------------|----------|----------|
| | | 6x4, 8x6 | 4x4, 6x6 | 6x4, 8x6 | 4x4, 6x6 | 6x4, 8x6 | 4x4, 6x6 | 6x4, 8x6 | 4x4, 6x6 | 6x4, 8x6 | 4x4, 6x6 |
| CT 11 & 13 | CAT SBA 116" BBC | 3.5° | - | 50.7" (1289 mm) | - | 8.6" (218.7 mm) | - | 0.5" (12.7 mm) | - | 0° | - |
| | CAT SBA 122" BBC | 3.5° | 1.5° | 50.7" (1289 mm) | 56.9" (1445 mm) | 8.6" (218.7 mm) | 4.8" (121.8 mm) | 0.5" (12.7 mm) | 0.5" (12.7 mm) | 1° | 1.2° |
| CT15 | CAT SBA 122" BBC | 3.5° | - | (2751.7 mm) | - | (1108 mm) | - | 0.5" (12.7 mm) | - | 0° | - |

ENGINE

CT11/13 ENGINE PORT LOCATION

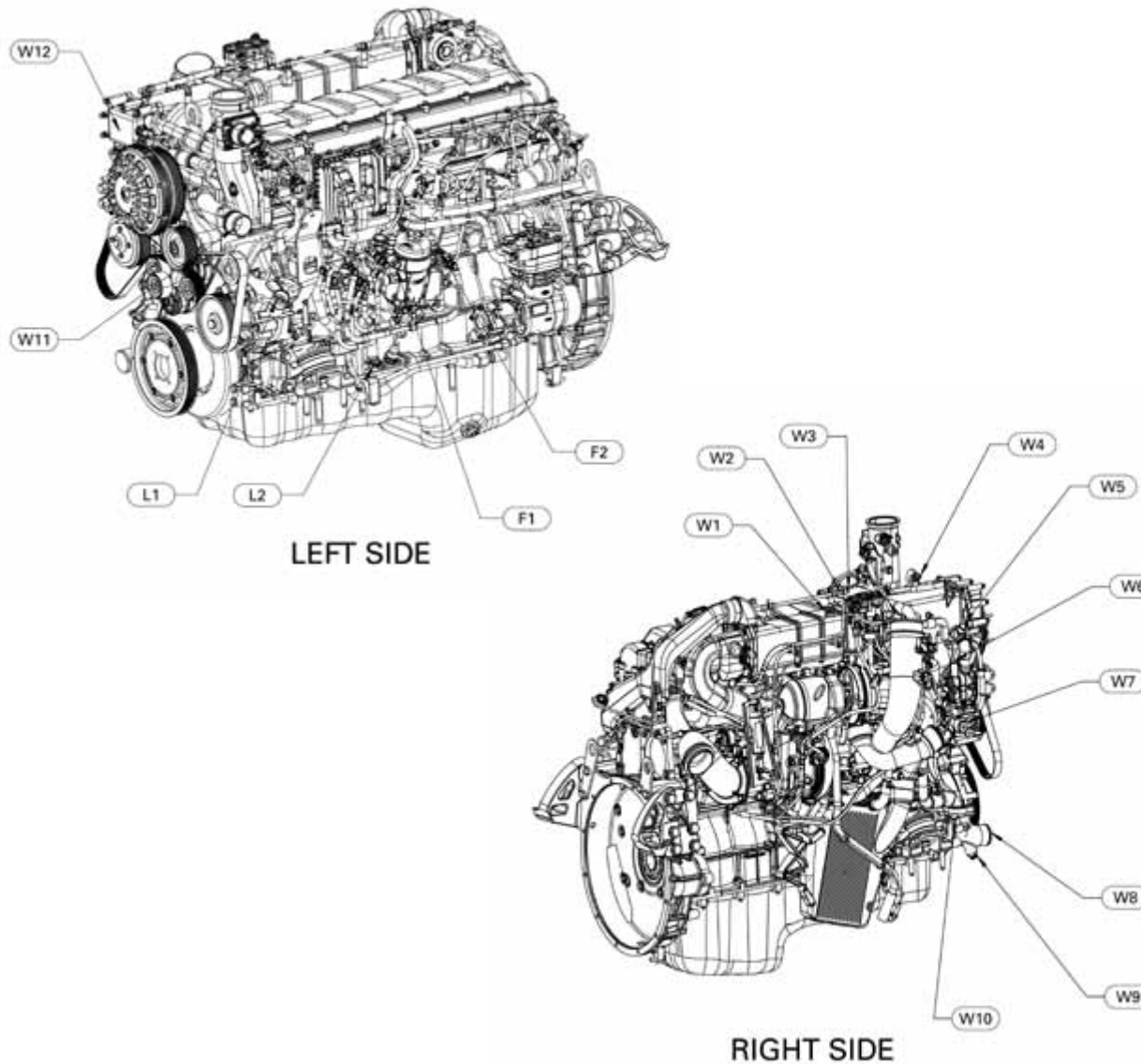

| TYPE | USAGE |
|--------------|---------------------------|
| WATER | |
| W1 | Heater Supply |
| W2 | Heater Return |
| W3 | Engine Vent |
| W4 | Engine Vent |
| W5 | Low Temp. Radiator Return |
| W6 | Low Temp. Radiator Supply |
| W7 | Coolant Supply |
| W8 | Coolant Inlet |
| W9 | Block Heater |
| W10 | Surge Line |
| W11 | Coolant Outlet |
| W12 | Coolant Supply |
| OIL | |
| L1 | Oil Fill |
| L2 | Dipstick |
| FUEL | |
| F1 | Fuel Inlet |
| F2 | Fuel Return |

ENGINE

CT15 ENGINE PORT LOCATION

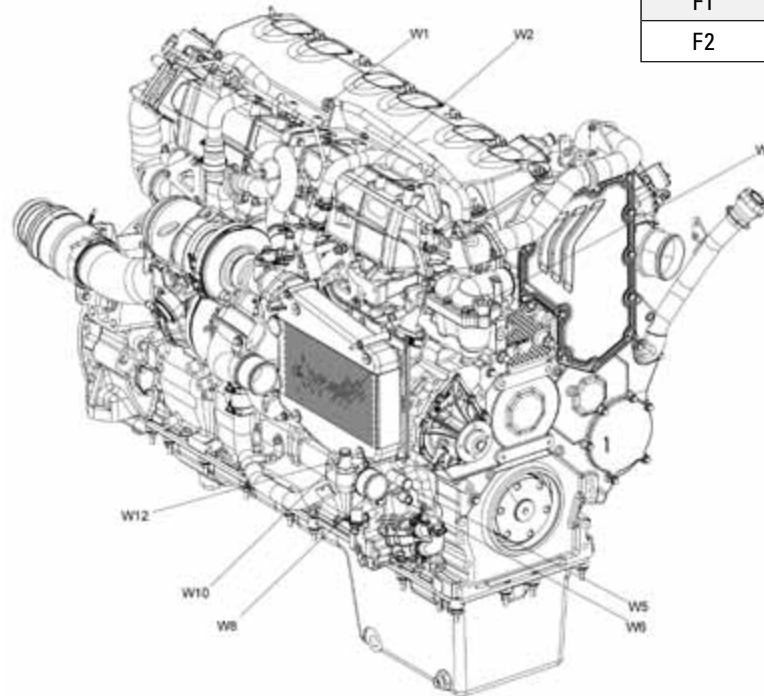
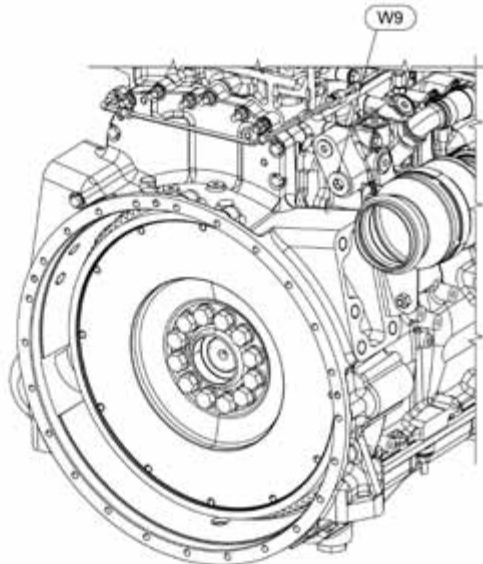
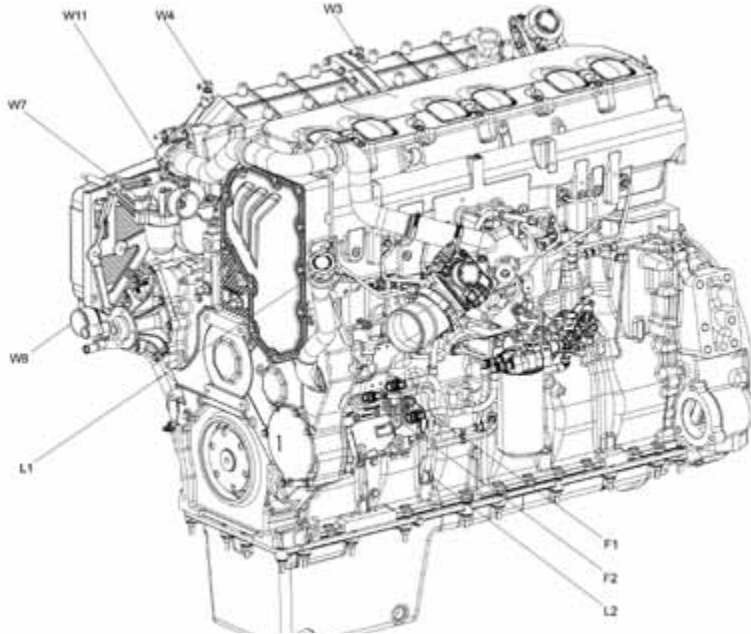

| TYPE | | USAGE |
|--------------|---------------------------|-------|
| WATER | | |
| W1 | Heater Supply | |
| W2 | Heater Return | |
| W3 | Engine Vent | |
| W4 | Engine Vent | |
| W5 | Low Temp. Radiator Return | |
| W6 | Low Temp. Radiator Supply | |
| W7 | Coolant Supply | |
| W8 | Coolant Inlet | |
| W9 | Block Heater | |
| W10 | Surge Line | |
| W11 | Coolant Outlet | |
| W12 | Coolant Supply | |
| OIL | | |
| L1 | Oil Fill | |
| L2 | Dipstick | |
| FUEL | | |
| F1 | Fuel Inlet | |
| F2 | Fuel Return | |

[↶ return to table of contents](#)

ENGINE

TORQUE/POWER CURVES

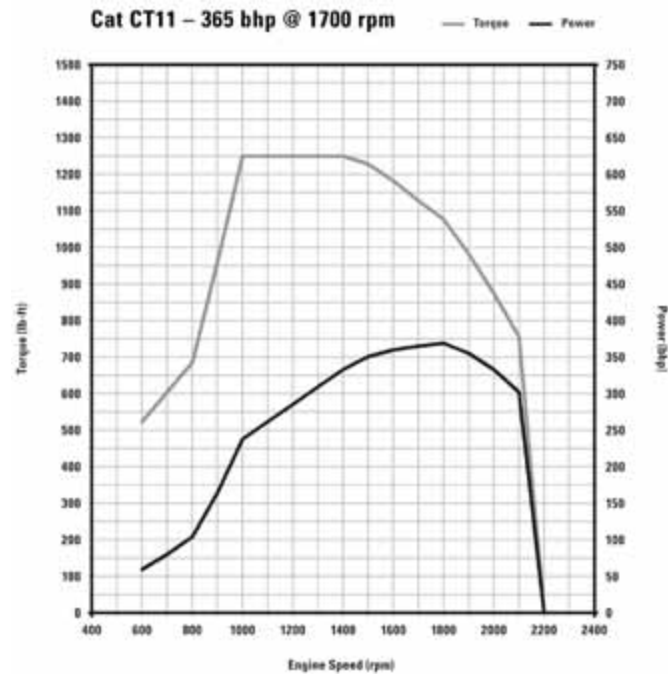
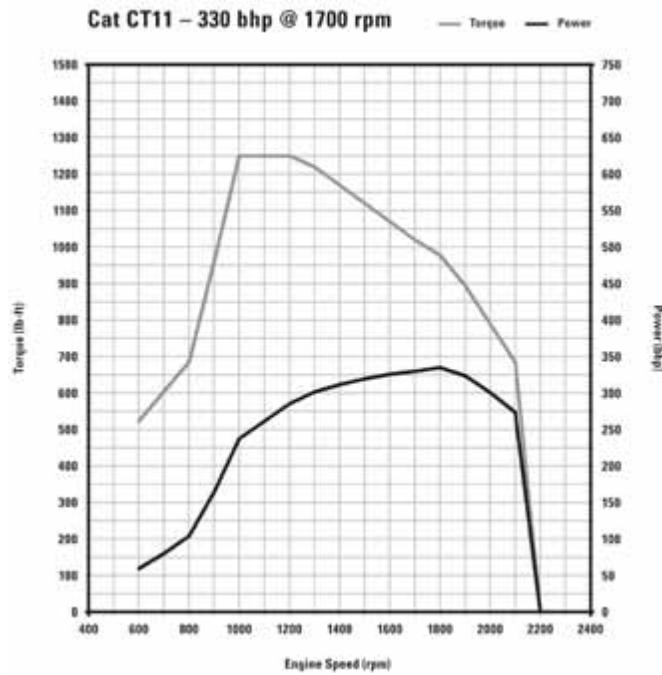

ENGINE

TORQUE/POWER CURVES

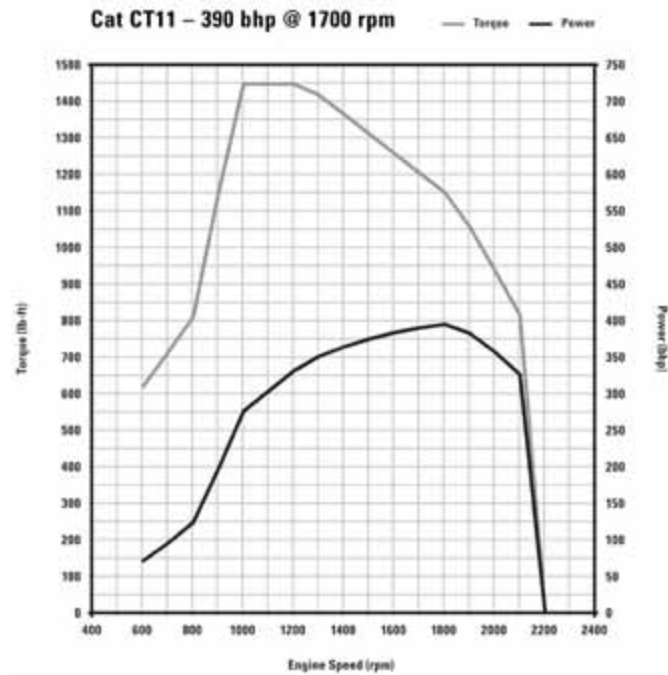
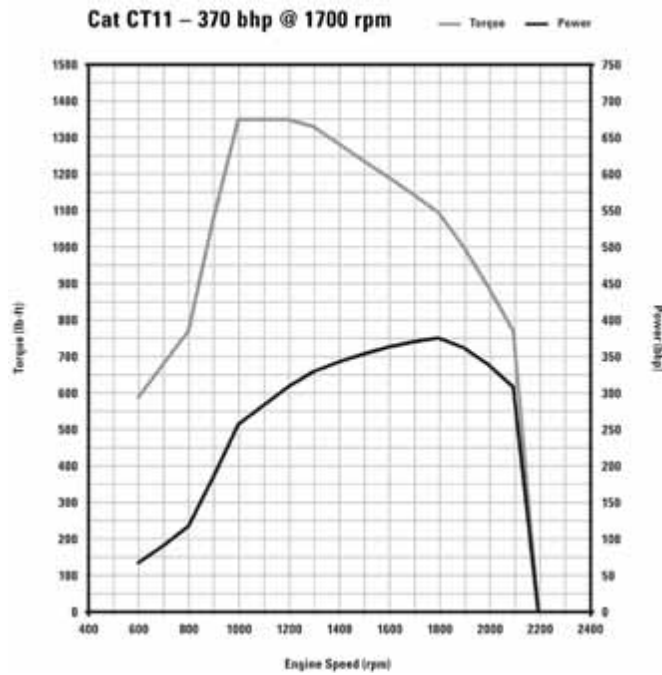

ENGINE

TORQUE/POWER CURVES

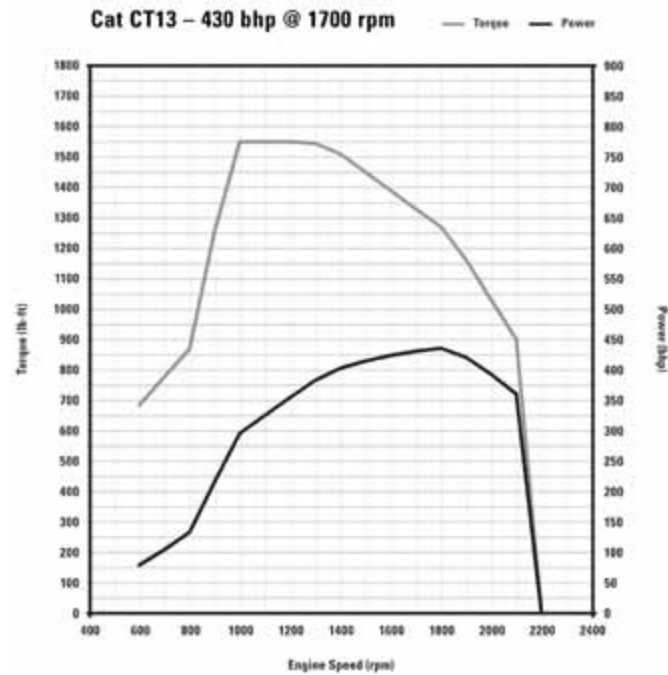
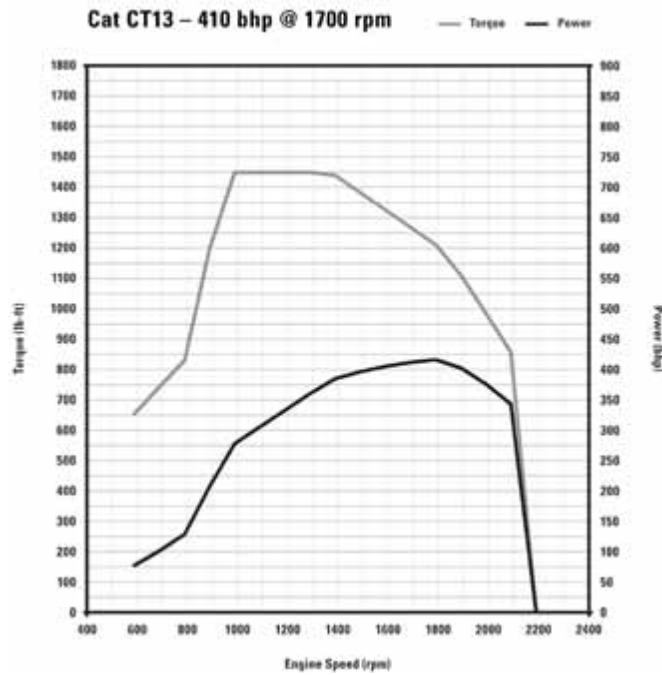

ENGINE

TORQUE/POWER CURVES

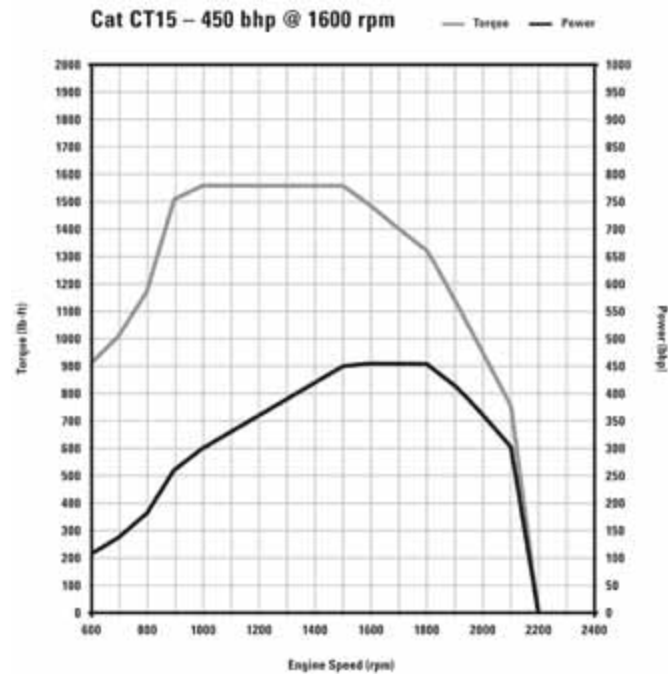
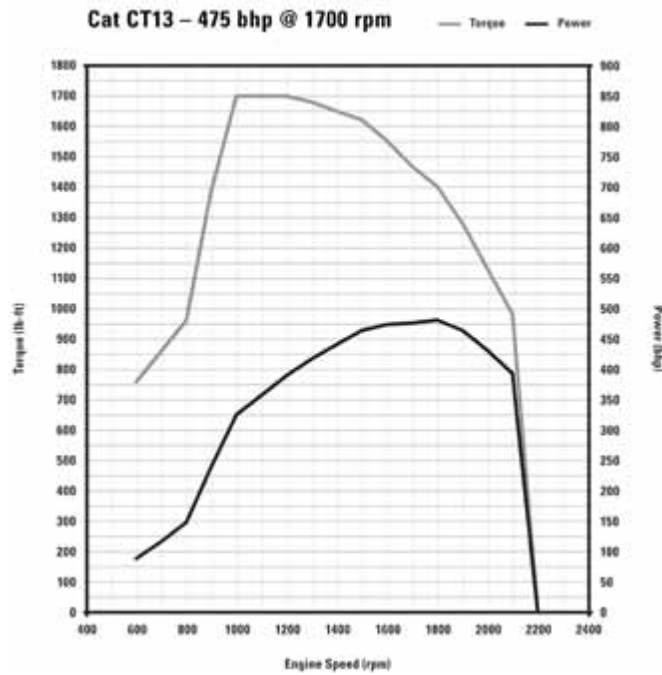

ENGINE

TORQUE/POWER CURVES

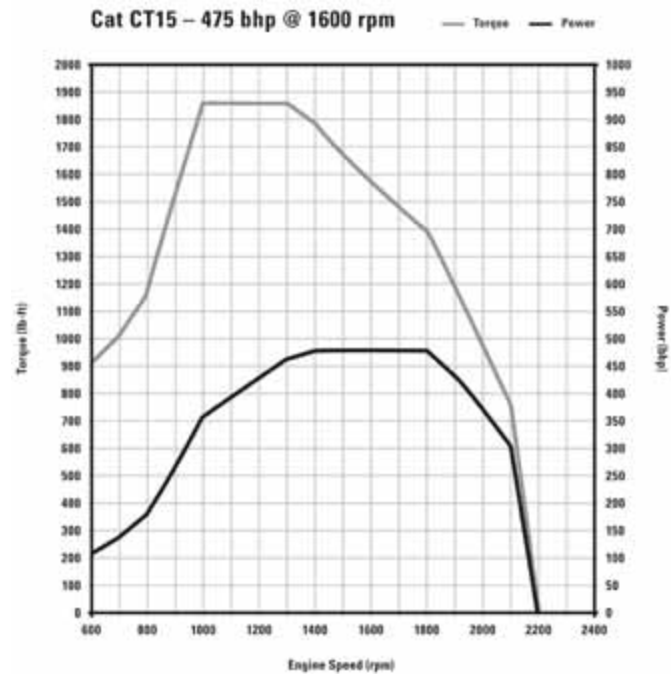
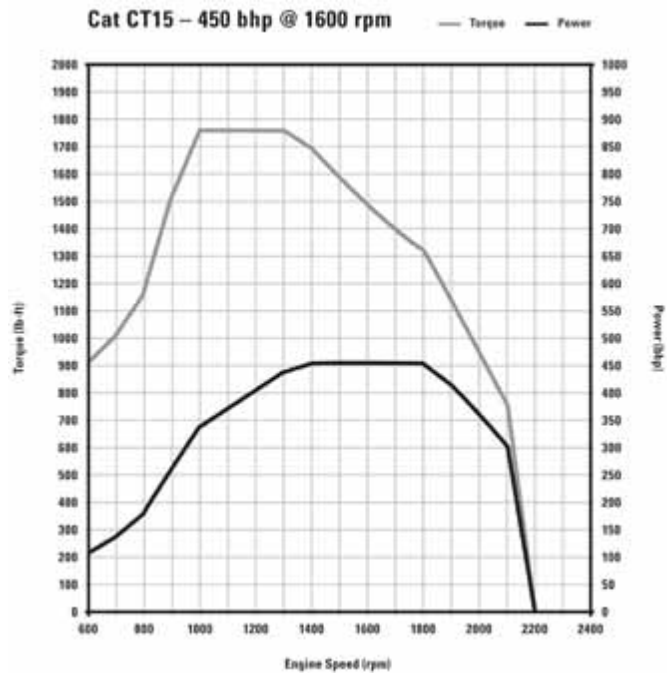

ENGINE

TORQUE/POWER CURVES

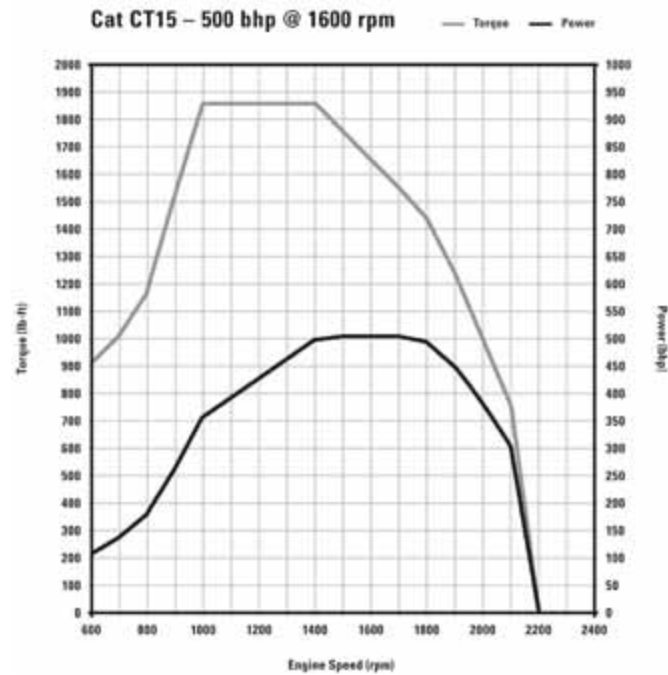
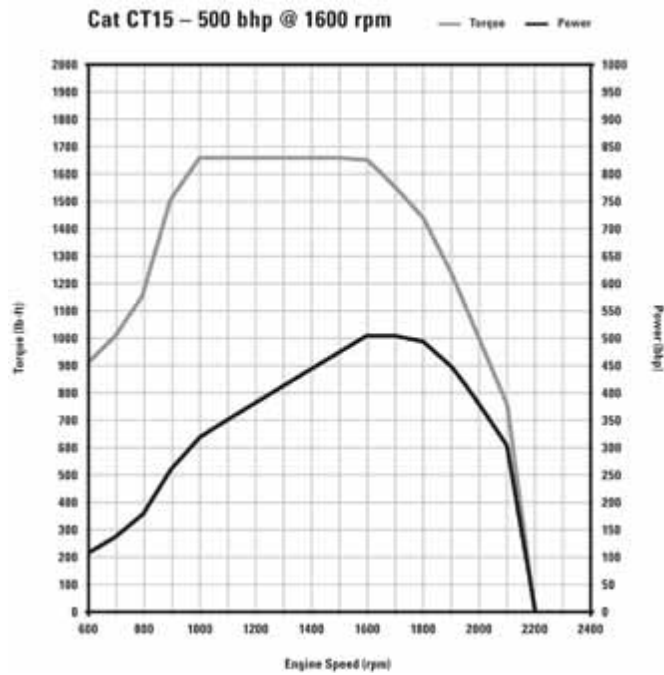

ENGINE

TORQUE/POWER CURVES

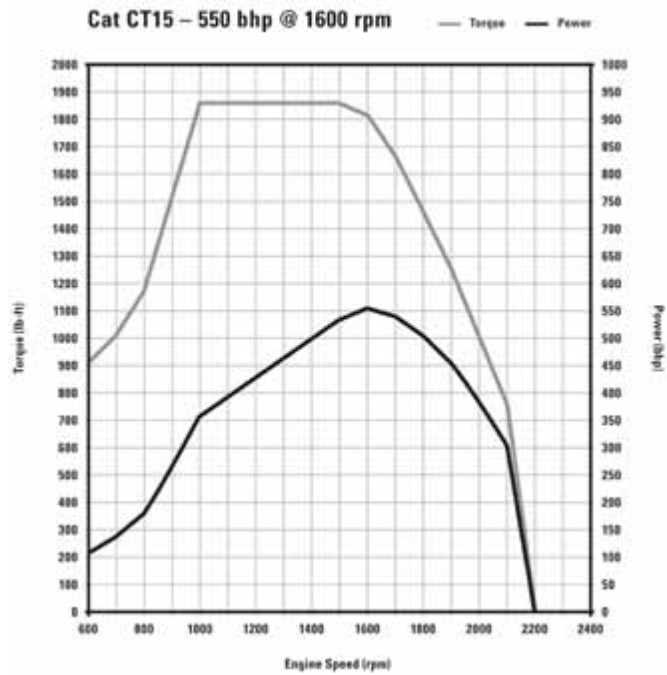

ENGINE

REMOTE RPM CONTROL HARNESS - 12WBX

This is the general description on the CT series engine wiring harness, Feature Code 12WBX, released in late 2012. The engine compartment wiring harness has Two 10 way connectors. Mating connectors are installed. Sealing plus are installed in all unused connector cavities. Circuit Connections are available for - but not limited to: Cruise Set/ Resume, Transfer Case Status, PTO Variable PRM Control Enable, PTO Preset Enable, Remote Throttle. The recommended chassis interface wiring size is 16 Ga.

12WBX Wiring

| 12WBX CONNECTOR #1 | | | | |
|--------------------|-----------------------|---------------------|----------------------|--------------------------------|
| Connector Pin | Signal | Engine Connector ID | Engine Connector Pin | Comment |
| A | + Batt | N/C | N/A | Shares Engine Ignition Circuit |
| B | PTO Preset Enable | 2 | 48 | |
| C | Variable PTO Enable | 2 | 35 | |
| D | Preset 1 (Set) | 2 | 52 | |
| E | Preset 2 (Resume) | 2 | 23 | |
| F | Speedometer | 2 | 30 | |
| G | Tach | 2 | 09 | |
| H | MIL | 1 | 57 | Level 2 warning level |
| J | Engine Running Output | 1 | 56 | |
| Open | N/A | N/A | N/A | |

ENGINE

REMOTE RPM CONTROL HARNESS - 12WBX CONT.

| 12WBX CONNECTOR #2 FEMALE SOCKETS | | | | |
|-----------------------------------|---------------------|---------------------|----------------------|------------------------|
| Connector Pin | Signal | Engine Connector ID | Engine Connector Pin | Comment |
| A | Remote Pedal Enable | 1 | 13 | Throttle Signal |
| B | 5V Reference | 2 | 37 | Throttle Supply |
| C | Sig GND | 2 | 24 | Throttle Signal Ground |
| D | Warning Lamp | 2 | 17 | |
| E | Stop Lamp | 2 | 28 | |
| F | Wait To Start Lamp | 2 | 25 | |
| G | Split Shaft / TCase | 2 | 10 | TCase Status |
| H | Future | 2 | 13 | |
| J | Remote Pedal Sw | 2 | 46 | Remote Throttle Enable |
| Open | N/A | N/A | N/A | |

Mating Connector Part Numbers

| CONNECTOR #1 | PIN/SOCKET |
|--------------|------------|
| 4153444 | 3962781 |

| CONNECTOR #2 | PIN/SOCKET |
|--------------|------------|
| 3962861 | 3962770 |

ENGINE

TORQUE/POWER CURVES - SCR

Cat CT13 – 410 bhp @ 1700 rpm

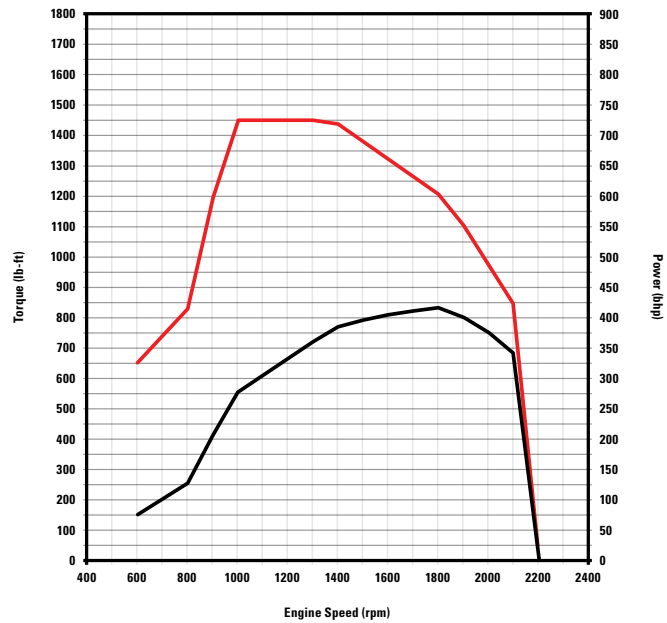

Cat CT13 – 430 bhp @ 1700 rpm

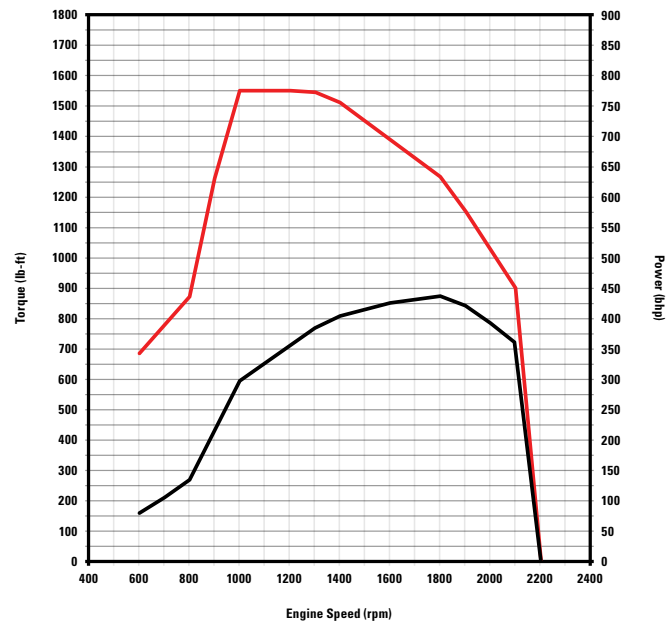

ENGINE

TORQUE/POWER CURVES -SCR

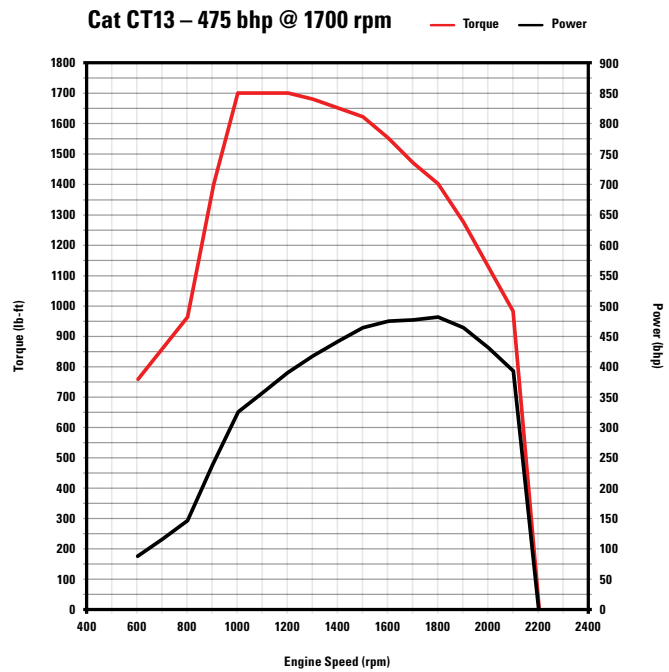

TRANSMISSION

PTO LOCATION

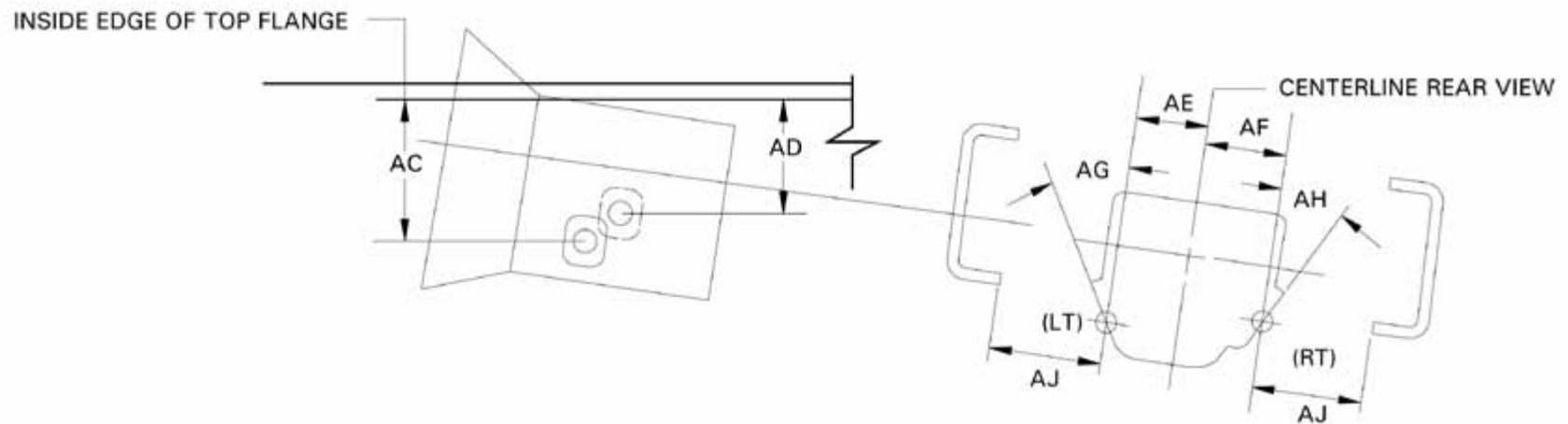

TRANSMISSION

PTO CONTROLS

The CX transmission provides a variety of features to match the PTO operation to the application. The electrical output and feature set is the same for side or rear mount PTO systems. The transmission does not differentiate between side or rear mount PTO systems.

Truck manufactured as of June 2012 will have programming in the CX transmission to support body builder installation of PTO electrical control system wiring.

Basic Wiring Diagram

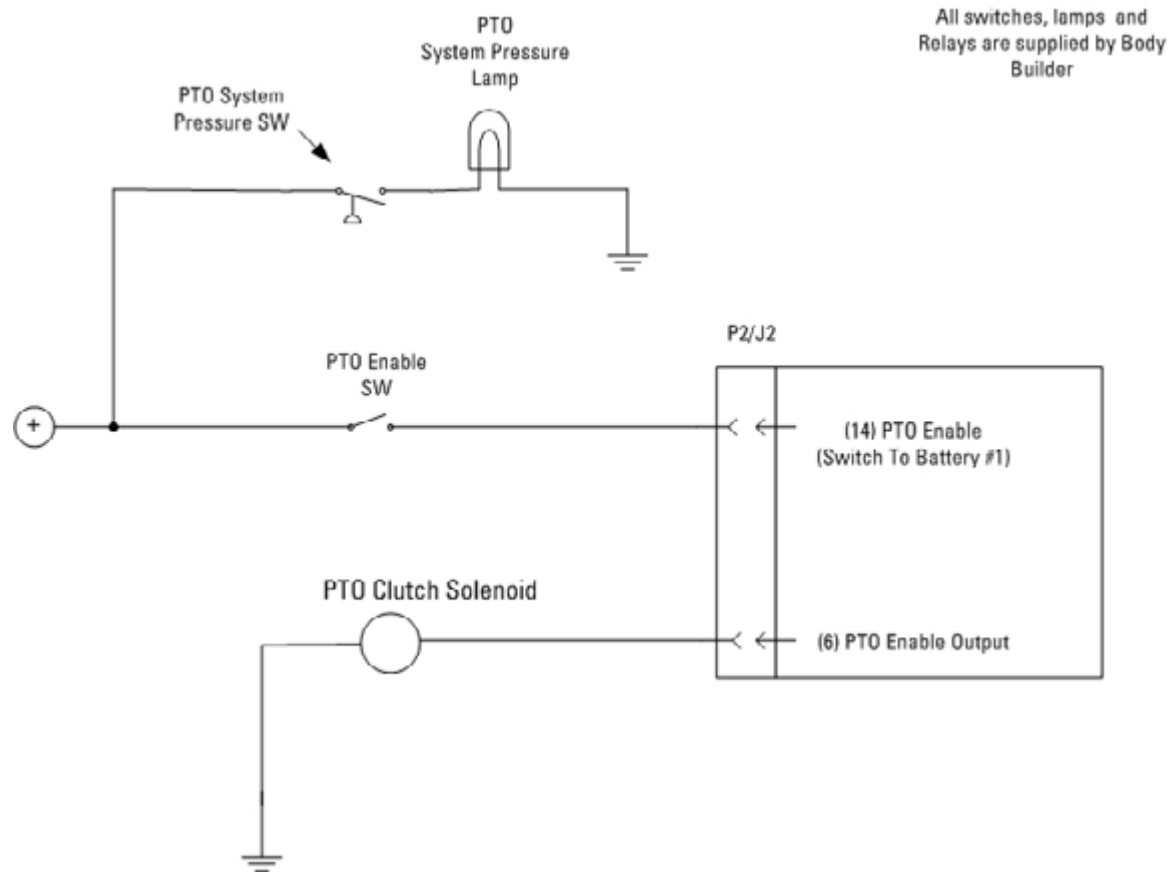

Note: Additional options for the PTO Enable Switch are available and may be required to allow other CX transmission features to function.

CX31 TRANSMISSION

Application and Instruction for Hot Shift PTO Control

The PTO Enabled output is capable of driving 2 amps at battery voltage. The output will be activated when the switch to Battery at J2: 14 is closed AND the engine RPM is below the programmed value. Transmissions in trucks built in June, 2012 will have the following programming:

| | |
|--|---------------------|
| Maximum Engine Speed for Engagement | 1000 RPM |
| Maximum Engine Speed for Operation | 2000 RPM |
| Maximum Transmission Output Speed for Engagement | 3000 RPM |
| Maximum Transmission Output Speed for Engagement | 3000 RPM |
| PTO Switch Input Configuration | Switch to Battery 1 |

This programming will allow the Hot Shift PTO clutch to engage when the engine is below 1000 RPM. The PTO output will turn OFF at 2000 RPM. The PTO clutch output will ignore Driveshaft speed. This programming will allow for PTO installation and testing.

| | |
|---|---------------------|
| PTO Enabled Status | ENABLED |
| PTO Mode Maximum Engine Speed for Engagement | 1000 RPM |
| PTO Mode Maximum Engine Speed for Operation | 2000 RPM |
| PTO Mode Maximum Transmission Output Speed for Engagement | 3000 RPM |
| PTO Mode Maximum Transmission Output Speed for Operation | 3000 RPM |
| PTO Switch Input Configuration | Switch to Battery 1 |

The Cat Transmission provides a variety of features to control Hot Shift PTO Clutch engagement. The PTO Enabled Output @ J2:6 (70 Pin Connector, location #6) is used to control the PTO System's Clutch.

CX31 TRANSMISSION

If desired, the PTO feature set allows for elaborate operation and fine-tuning of the PTO enabled output to meet customer requirements. This fine-tuning will require parameter programming using the Caterpillar electronic service tool software.

The following charts are examples of how the PTO output will operate with the listed programming.

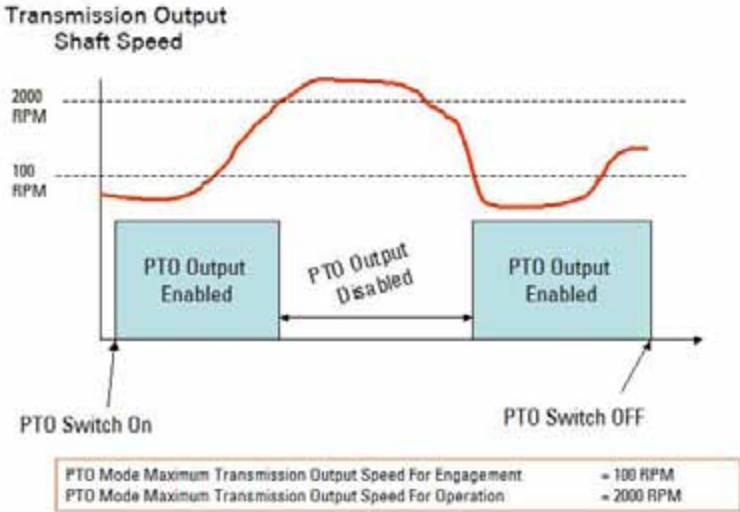
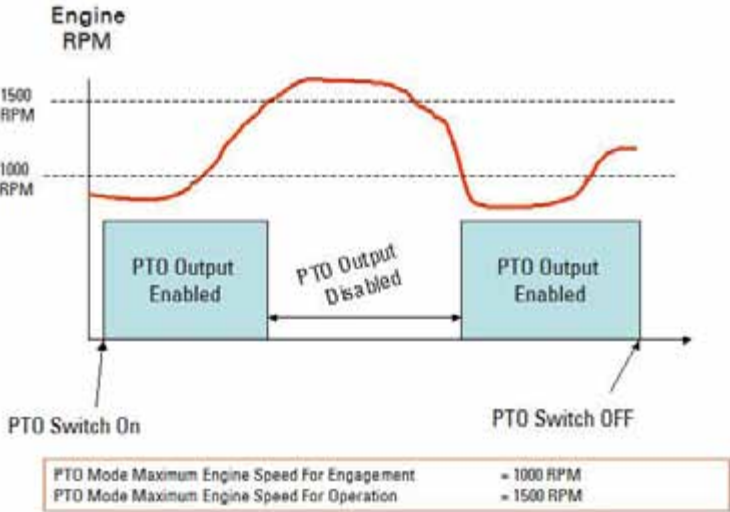

CX31 TRANSMISSION

Examples of PTO Output operation with gear related programming are as follows:

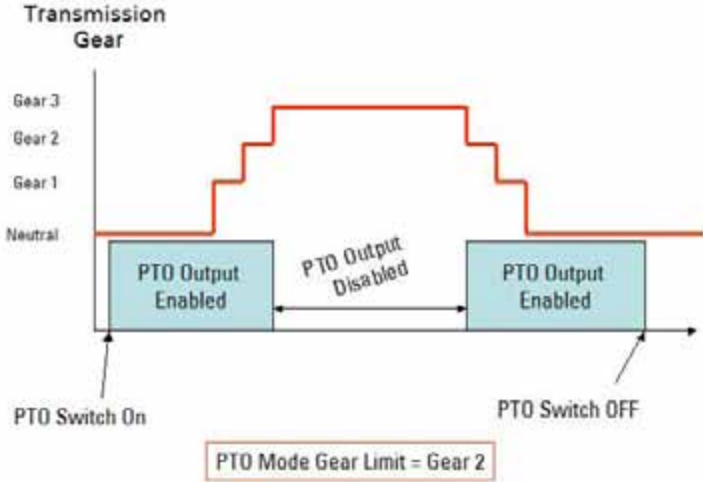
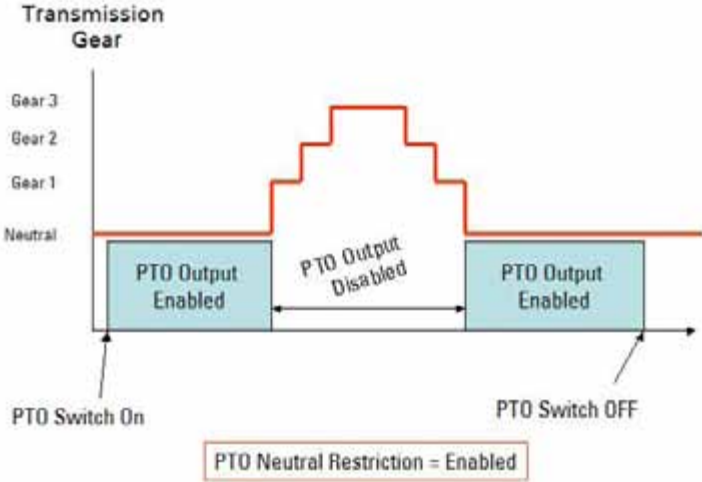

TRANSMISSION

CT11/13 PTO LOCATION — NON ALL WHEEL DRIVE

| TRANSMISSION | | ENGINE | LEFT PTO | RIGHT PTO | AC | AE | AG | (LT) AJ | AD | AF | AH | (RT) AJ | |
|--------------|---------|--|-------------------------------------|-----------|-------------------|-----|-----|---------|--------------------|-----|-----|---------|-----|
| | | | CLEARANCE PROVIDED FOR SAE ENVELOPE | | LEFT PTO LOCATION | | | | RIGHT PTO LOCATION | | | | |
| Auto Manual | 0013GSJ | Eaton 11-Speed UltraShift Plus, FO-14E309ALL-VMS | CT 11/13 | B | A | 302 | 140 | 90° | 222 | 172 | 231 | 47° | 106 |
| | 0013GTA | Eaton 18-Speed UltraShift Plus, FO-16E318B-VXP | CT 11/13 | B | A | 302 | 140 | 90° | 222 | 172 | 231 | 47° | 106 |
| | 0013GTB | Eaton 10-Speed UltraShift Plus, FO-16E308LL-VCS | CT 11/13 | B | A | 302 | 140 | 90° | 222 | 172 | 231 | 47° | 106 |
| | 0013GTG | Eaton 18-Speed UltraShift Plus, FO-18E318B-VXP | CT 11/13 | B | A | 302 | 140 | 90° | 222 | 172 | 231 | 47° | 106 |
| | 0013GTL | Eaton 11-Speed UltraShift Plus, FO-16E309ALL-VMS | CT 11/13 | B | A | 302 | 140 | 90° | 222 | 172 | 231 | 47° | 106 |
| | 0013GTM | Eaton 18-Speed UltraShift Plus, FO-14E318B-VXP | CT 11/13 | B | A | 302 | 140 | 90° | 222 | 172 | 231 | 47° | 106 |
| | 0013GTR | Eaton 10-Speed UltraShift Plus, FO-14E308LL-VCS | CT 11/13 | B | A | 302 | 140 | 90° | 222 | 172 | 231 | 47° | 106 |
| | 0013GUP | Eaton 10-Speed UltraShift Plus, FO-17E308LL-VCS | CT 11/13 | B | A | 302 | 140 | 90° | 222 | 172 | 231 | 47° | 106 |
| | 0013GUT | Eaton 11-Speed UltraShift Plus, FO-17E309ALL-VMS | CT 11/13 | B | A | 302 | 140 | 90° | 222 | 172 | 231 | 47° | 106 |
| Manual | 0013GGV | Fuller 10-Speed Manual, FRO-12210C | CT 11/13 | B | A | 299 | 140 | 90° | 222 | 188 | 210 | 59° | 127 |
| | 0013GHC | Fuller 10-Speed Manual, FRO-13210C | CT 11/13 | B | A | 299 | 140 | 90° | 222 | 188 | 210 | 59° | 127 |
| | 0013GHJ | Fuller 10-Speed Manual, FR-14210B | CT 11/13 | B | A | 299 | 140 | 90° | 222 | 188 | 210 | 59° | 127 |
| | 0013GHL | Fuller 10-Speed Manual, FRO-14210C | CT 11/13 | B | A | 299 | 140 | 90° | 222 | 188 | 210 | 59° | 127 |
| | 0013GHP | Fuller 10-Speed Manual, FRO-15210C | CT 11/13 | B | A | 299 | 140 | 90° | 222 | 188 | 210 | 59° | 127 |
| | 0013GHS | Fuller 10-Speed Manual, FRO-16210C | CT 11/13 | B | A | 299 | 140 | 90° | 222 | 188 | 210 | 59° | 127 |
| | 0013GHW | Fuller 10-Speed Manual, RTO(F)-14908LL | CT 11/13 | B | A | 302 | 140 | 90° | 222 | 172 | 231 | 47° | 106 |
| | 0013GHX | Fuller 10-Speed Manual, RTO(F)-16908LL | CT 11/13 | B | A | 302 | 140 | 90° | 222 | 172 | 231 | 47° | 106 |
| | 0013GHY | Fuller 15-Speed Manual, RTO(F)-16915 | CT 11/13 | B | A | 302 | 140 | 90° | 222 | 172 | 231 | 47° | 106 |
| | 0013GJS | Fuller 13-Speed Manual, RTLO-18913A | CT 11/13 | B | A | 302 | 140 | 90° | 222 | 172 | 231 | 47° | 106 |
| | 0013GKJ | Fuller 13-Speed Manual, RTLO-16913A | CT 11/13 | B | A | 302 | 140 | 90° | 222 | 172 | 231 | 47° | 106 |
| | 0013GKK | Fuller 18-Speed Manual, RTLO-14918B | CT 11/13 | B | A | 302 | 140 | 90° | 222 | 172 | 231 | 47° | 106 |
| | 0013GKL | Fuller 18-Speed Manual, RTLO-16918B | CT 11/13 | B | A | 302 | 140 | 90° | 222 | 172 | 231 | 47° | 106 |
| | 0013GKM | Fuller 18-Speed Manual, RTLO-18918B | CT 11/13 | B | A | 302 | 140 | 90° | 222 | 172 | 231 | 47° | 106 |
| | 0013GKZ | Fuller 10-Speed Manual, FRO-18210C | CT 11/13 | B | A | 302 | 140 | 90° | 222 | 172 | 231 | 47° | 106 |
| | 0013GMZ | Fuller 11-Speed Manual, RTO(F)-14909ALL | CT 11/13 | B | A | 302 | 140 | 90° | 222 | 172 | 231 | 47° | 106 |
| | 0013GNA | Fuller 11-Speed Manual, RTO(F)-16909ALL | CT 11/13 | B | A | 302 | 140 | 90° | 222 | 172 | 231 | 47° | 106 |
| | 0013GNM | Fuller 18-Speed Manual, RTLOF-20918B | CT 11/13 | B | A | 302 | 140 | 90° | 222 | 172 | 231 | 47° | 106 |
| | 0013GPX | Fuller 15-Speed Manual, RT(F)-14915 | CT 11/13 | B | A | 302 | 140 | 90° | 222 | 172 | 231 | 47° | 106 |
| | 0013GRD | Fuller 13-Speed Manual, RTLO(F)12913A | CT 11/13 | B | A | 302 | 140 | 90° | 222 | 172 | 231 | 47° | 106 |
| | 0013GRE | Fuller 13-Speed Manual, RTLO(F)14913A | CT 11/13 | B | A | 302 | 140 | 90° | 222 | 172 | 231 | 47° | 106 |
| Auto | 0013CZY | Cat® 6 SPEED Automatic, CX31 Retarder On/Off Hwy | CT 11/13 | C | C | 188 | 164 | 21° | 198 | -24 | 87 | 122° | 249 |
| | 0013CZZ | Cat® 6 SPEED Automatic, CX31 On/Off Hwy | CT 11/13 | C | C | 188 | 164 | 21° | 198 | -24 | 87 | 122° | 249 |

NOTE: A = SAE Type 1 (6-Bolt)
 B = SAE Type 2 (8-Bolt)
 C = Not Qualified (10-Bolt)

FOR NON ALL WHEEL DRIVE MODELS:
 SBA 116-122" - 6x4, 8x6

↶ return to table of contents

TRANSMISSION

CT11/13 PTO LOCATION — ALL WHEEL DRIVE

| TRANSMISSION | | ENGINE | LEFT PTO | RIGHT PTO | AC | AE | AG | (LT) AJ | AD | AF | AH | (RT) AJ | |
|--------------|---------|---|-------------------------------------|-----------|-------------------|-----|-----|---------|--------------------|-----|-----|---------|-----|
| | | | CLEARANCE PROVIDED FOR SAE ENVELOPE | | LEFT PTO LOCATION | | | | RIGHT PTO LOCATION | | | | |
| Auto Manual | 0013GSJ | Eaton 11-Speed UltraShift Plus, FO-14E309ALL-VMS | CT 11/13 | B | A | 302 | 140 | 90° | 222 | 172 | 231 | 47° | 106 |
| | 0013GTA | Eaton 18-Speed UltraShift Plus, FO-16E318B-VXP | CT 11/13 | B | A | 302 | 140 | 90° | 222 | 172 | 231 | 47° | 106 |
| | 0013GTB | Eaton 10-Speed UltraShift Plus, FO-16E308LL-VCS | CT 11/13 | B | A | 302 | 140 | 90° | 222 | 172 | 231 | 47° | 106 |
| | 0013GTG | Eaton 18-Speed UltraShift Plus, FO-18E318B-VXP | CT 11/13 | B | A | 302 | 140 | 90° | 222 | 172 | 231 | 47° | 106 |
| | 0013GTL | Eaton 11-Speed UltraShift Plus, FO-16E309ALL-VMS | CT 11/13 | B | A | 302 | 140 | 90° | 222 | 172 | 231 | 47° | 106 |
| | 0013GTM | Eaton 18-Speed UltraShift Plus, FO-14E318B-VXP | CT 11/13 | B | A | 302 | 140 | 90° | 222 | 172 | 231 | 47° | 106 |
| | 0013GTR | Eaton 10-Speed UltraShift Plus, FO-14E308LL-VCS | CT 11/13 | B | A | 302 | 140 | 90° | 222 | 172 | 231 | 47° | 106 |
| | 0013GUP | Eaton 10-Speed UltraShift Plus, FO-17E308LL-VCS | CT 11/13 | B | A | 302 | 140 | 90° | 222 | 172 | 231 | 47° | 106 |
| | 0013GUT | Eaton 11-Speed UltraShift Plus, FO-17E309ALL-VMS | CT 11/13 | B | A | 302 | 140 | 90° | 222 | 172 | 231 | 47° | 106 |
| Manual | 0013GGV | Fuller 10-Speed Manual, FRO-12210C | CT 11/13 | B | A | 299 | 140 | 90° | 222 | 188 | 210 | 59° | 127 |
| | 0013GHC | Fuller 10-Speed Manual, FRO-13210C | CT 11/13 | B | A | 299 | 140 | 90° | 222 | 188 | 210 | 59° | 127 |
| | 0013GHJ | Fuller 10-Speed Manual, FR-14210B | CT 11/13 | B | A | 299 | 140 | 90° | 222 | 188 | 210 | 59° | 127 |
| | 0013GHL | Fuller 10-Speed Manual, FRO-14210C | CT 11/13 | B | A | 299 | 140 | 90° | 222 | 188 | 210 | 59° | 127 |
| | 0013GHP | Fuller 10-Speed Manual, FRO-15210C | CT 11/13 | B | A | 299 | 140 | 90° | 222 | 188 | 210 | 59° | 127 |
| | 0013GHS | Fuller 10-Speed Manual, FRO-16210C | CT 11/13 | B | A | 299 | 140 | 90° | 222 | 188 | 210 | 59° | 127 |
| | 0013GHW | Fuller 10-Speed Manual, RTO(F)-14908LL | CT 11/13 | B | A | 302 | 140 | 90° | 222 | 172 | 231 | 47° | 106 |
| | 0013GHX | Fuller 10-Speed Manual, RTO(F)-16908LL | CT 11/13 | B | A | 302 | 140 | 90° | 222 | 172 | 231 | 47° | 106 |
| | 0013GHY | Fuller 15-Speed Manual, RTO(F)-16915 | CT 11/13 | B | A | 302 | 140 | 90° | 222 | 172 | 231 | 47° | 106 |
| | 0013GJS | Fuller 13-Speed Manual, RTLO-18913A | CT 11/13 | B | A | 302 | 140 | 90° | 222 | 172 | 231 | 47° | 106 |
| | 0013GKJ | Fuller 13-Speed Manual, RTLO-16913A | CT 11/13 | B | A | 302 | 140 | 90° | 222 | 172 | 231 | 47° | 106 |
| | 0013GKK | Fuller 18-Speed Manual, RTLO-14918B | CT 11/13 | B | A | 302 | 140 | 90° | 222 | 172 | 231 | 47° | 106 |
| | 0013GKL | Fuller 18-Speed Manual, RTLO-16918B | CT 11/13 | B | A | 302 | 140 | 90° | 222 | 172 | 231 | 47° | 106 |
| | 0013GKM | Fuller 18-Speed Manual, RTLO-18918B | CT 11/13 | B | A | 302 | 140 | 90° | 222 | 172 | 231 | 47° | 106 |
| | 0013GKZ | Fuller 10-Speed Manual, FRO-18210C | CT 11/13 | B | A | 302 | 140 | 90° | 222 | 172 | 231 | 47° | 106 |
| | 0013GMZ | Fuller 11-Speed Manual, RTO(F)-14909ALL | CT 11/13 | B | A | 302 | 140 | 90° | 222 | 172 | 231 | 47° | 106 |
| | 0013GNA | Fuller 11-Speed Manual, RTO(F)-16909ALL | CT 11/13 | B | A | 302 | 140 | 90° | 222 | 172 | 231 | 47° | 106 |
| | 0013GNM | Fuller 18-Speed Manual, RTLOF-20918B | CT 11/13 | B | A | 302 | 140 | 90° | 222 | 172 | 231 | 47° | 106 |
| | 0013GPX | Fuller 15-Speed Manual, RT(F)-14915 | CT 11/13 | B | A | 302 | 140 | 90° | 222 | 172 | 231 | 47° | 106 |
| | 0013GRD | Fuller 13-Speed Manual, RTLO(F)12913A | CT 11/13 | B | A | 302 | 140 | 90° | 222 | 172 | 231 | 47° | 106 |
| | 0013GRE | Fuller 13-Speed Manual, RTLO(F)14913A | CT 11/13 | B | A | 302 | 140 | 90° | 222 | 172 | 231 | 47° | 106 |
| Auto | 0013CZY | Caterpillar 6 SPEED Automatic, CX31 Retarder On/Off Hwy | CT 11/13 | C | C | 188 | 164 | 21° | 198 | -24 | 87 | 122° | 249 |
| | 0013CZZ | Caterpillar 6 SPEED Automatic, CX31 On/Off Hwy | CT 11/13 | C | C | 188 | 164 | 21° | 198 | -24 | 87 | 122° | 249 |

NOTE: A = SAE Type 1 (6-Bolt)
 B = SAE Type 2 (8-Bolt)
 C = Not Qualified (10-Bolt)

FOR ALL WHEEL DRIVE MODELS:
 SBA 4x4 - 6x6

↪ return to table of contents

TRANSMISSION

CT15 PTO LOCATION

| TRANSMISSION | | ENGINE | LEFT PTO | RIGHT PTO | AC | AE | AG | (LT) AJ | AD | AF | AH | (RT) AJ | |
|--------------|---------|---|-------------------------------------|-----------|-------------------|-----|-----|---------|--------------------|------|-----|---------|-----|
| | | | CLEARANCE PROVIDED FOR SAE ENVELOPE | | LEFT PTO LOCATION | | | | RIGHT PTO LOCATION | | | | |
| Auto Manual | 0013GTA | Eaton 18-Speed UltraShift Plus, FO-16E318B-VXP | CT15 | B | A | 374 | 140 | 90° | 222 | 244 | 231 | 47° | 106 |
| | 0013GTB | Eaton 10-Speed UltraShift Plus, FO-16E308LL-VCS | CT15 | B | A | 374 | 140 | 90° | 222 | 244 | 231 | 47° | 106 |
| | 0013GTG | Eaton 18-Speed UltraShift Plus, FO-18E318B-VXP | CT15 | B | A | 374 | 140 | 90° | 222 | 244 | 231 | 47° | 106 |
| | 0013GTL | Eaton 11-Speed UltraShift Plus, FO-16E309ALL-VMS | CT15 | B | A | 374 | 140 | 90° | 222 | 244 | 231 | 47° | 106 |
| | 0013GUP | Eaton 10-Speed UltraShift Plus, FO-17E308LL-VCS | CT15 | B | A | 374 | 140 | 90° | 222 | 244 | 231 | 47° | 106 |
| | 0013GUT | Eaton 11-Speed UltraShift Plus, FO-17E309ALL-VMS | CT15 | B | A | 374 | 140 | 90° | 222 | 244 | 231 | 47° | 106 |
| Manual | 0013GHP | Fuller 10-Speed Manual, FRO-15210C | CT15 | B | A | 370 | 140 | 90° | 222 | 258 | 210 | 59° | 127 |
| | 0013GHS | Fuller 10-Speed Manual, FRO-16210C | CT15 | B | A | 370 | 140 | 90° | 222 | 258 | 210 | 59° | 127 |
| | 0013GKZ | Fuller 10-Speed Manual, FRO-18210C | CT15 | B | A | 370 | 140 | 90° | 222 | 258 | 231 | 47° | 106 |
| | 0013GHX | Fuller 10-Speed Manual, RTO(F)-16908LL | CT15 | B | A | 371 | 140 | 90° | 222 | 241 | 231 | 47° | 106 |
| | 0013GHY | Fuller 15-Speed Manual, RTO(F)-16915 | CT15 | B | A | 371 | 140 | 90° | 222 | 241 | 231 | 47° | 106 |
| | 0013GJS | Fuller 13-Speed Manual, RTLO-18913A | CT15 | B | A | 371 | 140 | 90° | 222 | 241 | 231 | 47° | 106 |
| | 0013GKJ | Fuller 13-Speed Manual, RTLO-16913A | CT15 | B | A | 371 | 140 | 90° | 222 | 241 | 231 | 47° | 106 |
| | 0013GKL | Fuller 18-Speed Manual, RTLO-16918B | CT15 | B | A | 371 | 140 | 90° | 222 | 241 | 231 | 47° | 106 |
| | 0013GKM | Fuller 18-Speed Manual, RTLO-18918B | CT15 | B | A | 371 | 140 | 90° | 222 | 241 | 231 | 47° | 106 |
| | 0013GNA | Fuller 11-Speed Manual, RTO(F)-16909ALL | CT15 | B | A | 371 | 140 | 90° | 222 | 241 | 231 | 47° | 106 |
| | 0013GNM | Fuller 18-Speed Manual, RTLOF-20918B | CT15 | B | A | 371 | 140 | 90° | 222 | 241- | 231 | 47° | 106 |
| Auto | 0013AMM | Allison 5-Speed Automatic, 4500_RDS On/Off Hwy | CT15 | C | C | 271 | 161 | 26° | 201 | 27 | 55 | 110° | 282 |
| | 0013AMN | Allison 6-Speed Automatic, 4500_RDS On/Off Hwy | CT15 | C | C | 271 | 161 | 26° | 201 | 27 | 55 | 110° | 282 |
| | 0013AMP | Allison 5-Speed Automatic, 4500_RDS Refuse | CT15 | C | C | 271 | 161 | 26° | 201 | 27 | 55 | 110° | 282 |
| | 0013AMR | Allison 6-Speed Automatic, 4500_RDS Refuse | CT15 | C | C | 271 | 161 | 26° | 201 | 27 | 55 | 110° | 282 |
| | 0013AMS | Allison 5-Speed Automatic, 4000_RDS On/Off Hwy | CT15 | C | C | 271 | 161 | 26° | 201 | 27 | 55 | 110° | 282 |
| | 0013AMT | Allison 6-Speed Automatic, 4000_RDS On/Off Hwy | CT15 | C | C | 271 | 161 | 26° | 201 | 27 | 55 | 110° | 282 |
| | 0013AMU | Allison 5-Speed Automatic, 4000_RDS Refuse | CT15 | C | C | 271 | 161 | 26° | 201 | 27 | 55 | 110° | 282 |
| | 0013AMV | Allison 6-Speed Automatic, 4000_RDS Refuse | CT15 | C | C | 271 | 161 | 26° | 201 | 27 | 55 | 110° | 282 |
| | 0013CZY | Caterpillar 6 SPEED Automatic, CX31 Retarder On/Off Hwy | CT15 | C | C | 257 | 164 | 21° | 198 | 46 | 87 | 122° | 249 |
| | 0013CZZ | 6 SPEED Automatic, CX31 On/Off Hwy | CT15 | C | C | 257 | 164 | 21° | 198 | 46 | 87 | 122° | 249 |

NOTE: A = SAE Type 1 (6-Bolt)
 B = SAE Type 2 (8-Bolt)
 C = Not Qualified (10-Bolt)

FOR ALL WHEEL DRIVE MODELS:
 SBA 4x4 - 6x6

↶ return to table of contents

TRANSMISSION

TRANSFER CASE MOUNTING LOCATION — 0013TLC TC-180

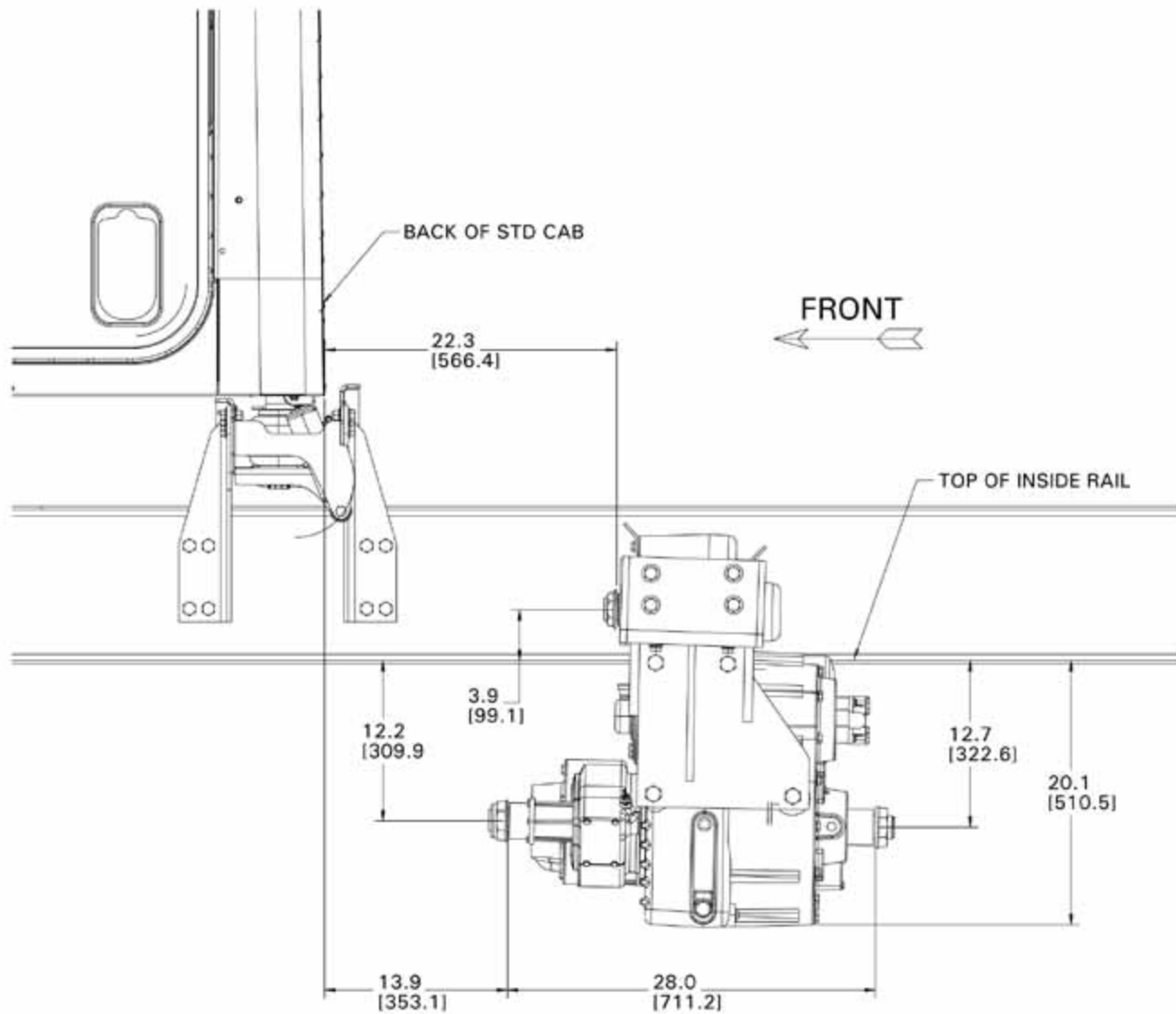

TRANSMISSION

TRANSFER CASE MOUNTING LOCATION — 0013TJP TC-270

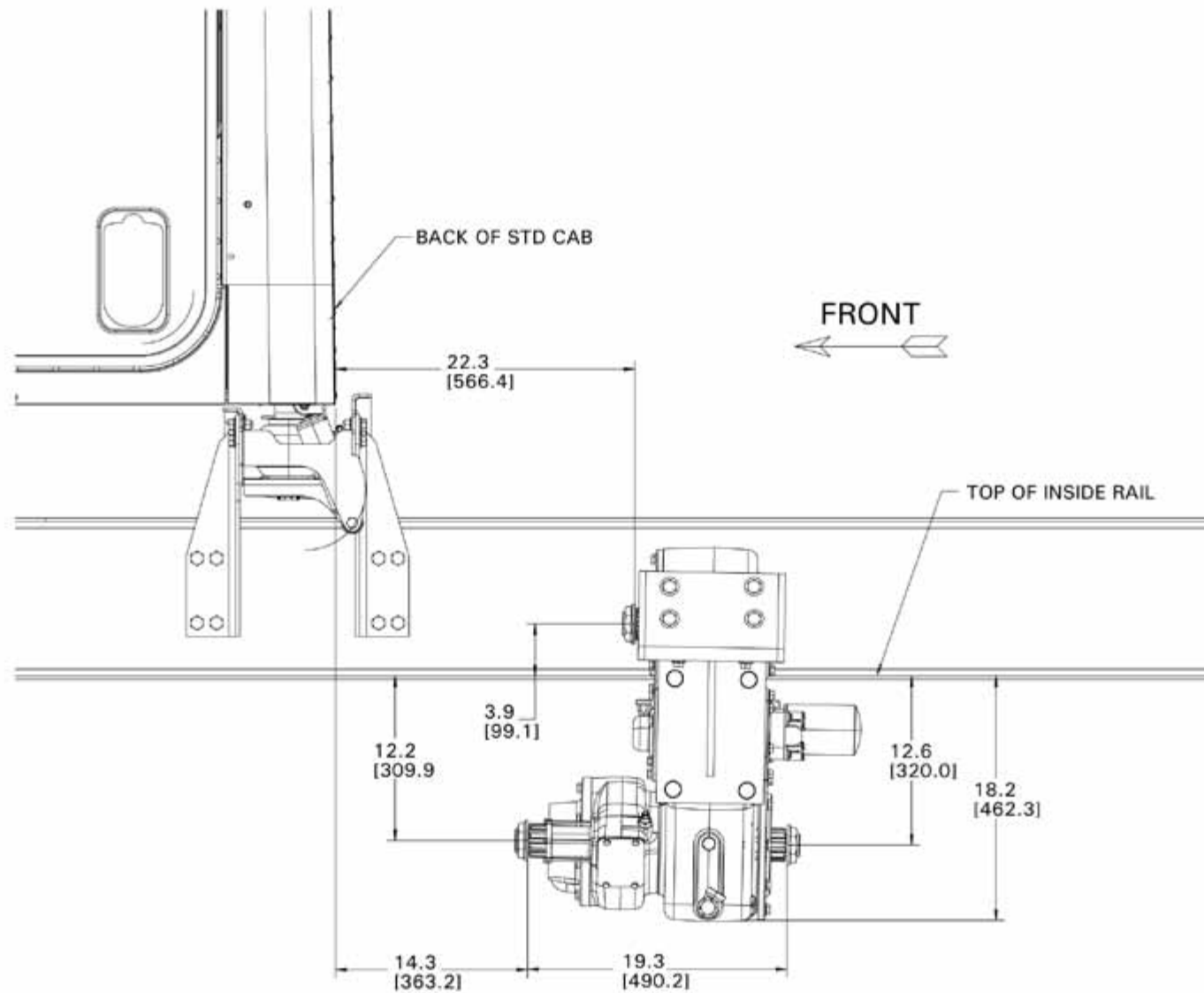

CX31 TRANSMISSION

PTO POWER CAPABILITY — INTERACTIVE CALCULATOR

Input your engine rpm into the entry field below and press enter to determine Total Possible Truck PTO Power.

| ENGINE SPEED ← INPUT ENGINE RPM HERE AND PRESS ENTER | | | | |
|---|-------------------------|-----------------------|----------------------|--------------------|
| PTO LOCATION | ALLOWABLE TORQUE (LBFT) | PERCENT OF ENGINE RPM | PTO ROTATIONAL SPEED | PTO HP CAPABILITY* |
| TOTAL PTO POWER ALLOWED AT ANY ONE TIME | | | | |
| REAR TRANSMISSION | 800 | 1.25 | | |
| SIDE TRANSMISSION | 400 | 1 | | |
| | 1200 | — | — | |
| SIDE PTO POWER ALLOWED IF RTPTO IS NOT RUNNING | | | | |
| SIDE TRANSMISSION | 700 | 1 | | |
| REAR ENGINE PTO POWER ALLOWED (IN ADDITION TO TRANS PTOS) | | | | |
| REAR ENGINE | 480 | 1.233 | | |
| TOTAL POSSIBLE TRUCK PTO POWER (TRANSMISSION AND ENGINE) | | | | |
| | 1680 | — | — | |

*To achieve this number, the engine gross HP rating, minus all parasitic losses (fan, A/C, air compressor, driveline) must equal or exceed this figure.

[↶ return to table of contents](#)

CX31 TRANSMISSION

POWER TRAIN OIL SYSTEM

The power train oil schematic shown in Illustrations 14 and 15 provides the nominal pressures and flows within the CX31 power train. The CX31 has different oil schematics based on the oil routing for different gears. Gears first and second converter, second and third direct, and fourth through sixth, share the same schematics based on hydraulic logic.

The OEM selection of the oil cooler and its lines routing needs to be sized so that flows, back pressures, and cooling are adequate for the application. In general, the hoses need to be as short and straight as the installations will allow. The cooler section of this guide provides line routing specifics.

The transmission fluid is critical to the proper operation of the transmission because it serves many functions such as the following: proper cooling, clutch engagement, bearing protection, torque converter operation and general overall interior oxidation protection. In order to maintain the cleanliness of the fluid, the filter must be changed as recommended.

Fluid Recommendations

The CX Series of on-highway transmissions are designed to operate with ATF fluids that meet Caterpillar AT-1 or Dexron IIIH specifications. Extended oil change intervals, require synthetic oils meeting Caterpillar AT-1 specifications. Cat® ATF synthetic oil is available through Cat Dealers. Refer to the Operation and Maintenance Manual for oil change intervals based on applications.

Note: Do not use Cat TDO-4 oil in the CX Series of on-highway transmissions.

Note: During a system failure of internal components, the power train generates abrasive debris that circulates throughout the system. The debris can cause the valves, the power train, pumps, and actuators to suffer repeat failures. Thoroughly clean debris from the system after a component failure and replace the transmission oil cooler core in order to prevent repeat failures. Refer to Operation and Maintenance Manual, SEBU6250, “Caterpillar Machine Fluids Recommendations” for information on improving the durability of machine components and for additional fluid information.

Temperature Operating Limits

The maximum allowable transmission oil temperatures for normal (i.e. continuous) and intermittent (i.e. testing) conditions are the following:

- » **Continuous sump ... 93 °C (200 °F)**
- » **Continuous converter out ... 121 °C (250 °F)**
- » **Intermittent sump ... 121 °C (250 °F)**
- » **Intermittent converter out ... 149 °C (300 °F)**

CX31 TRANSMISSION

POWER TRAIN OIL SYSTEM

Oil Temperature Gauges

If the OEM chooses to use a color-coded **converter outlet temperature** gauge, the following recommendations apply:

- » **Green - Safe zone is below 121 °C (250 °F)**
- » **Yellow - Caution zone is 121 °C (250 °F) - 149 °C (300 °F)**

The following requirement applies:

- » **Red - Warning zone above 149 °C (300 °F)**

If the OEM chooses to use a color-coded **sump temperature** gauge, the following recommendations apply:

- » **Green - Safe zone is below 93 °C (200 °F)**
- » **Yellow - Caution zone 93 °C (200 °F) - 121 °C (250 °F)**

The following requirement applies:

- » **Red - Warning zone above 121 °C (250 °F)**

NOTICE: Operators may use the Yellow zone on an intermittent basis for a short period of time. Operation above the Red line for short periods of time can result in damage to the oil and the transmission.

Transmission Oil Volumes

| TRANSMISSION TYPE | ESTIMATED INITIAL FILL | SERVICE REFILL |
|--------------------|------------------------|-------------------|
| CX31 Shallow Sump | 38 L (10.0 US gal) | 20 L (5.3 US gal) |
| CX31 Standard Sump | 43 L (11.3 US gal) | 25 L (6.5 US gal) |
| CX31 with Retarder | 54 L (14.2 US gal) | 27 L (7 US gal) |

Table 11

Note: The estimated initial fill volumes will vary by installation, depending on the volume of the oil cooler and the associated lines group.

CX31 TRANSMISSION

POWER TRAIN OIL SYSTEM

Optional Remote Transmission Oil Filter

| REMOTE OIL FILTER HOSES | | | |
|-------------------------|-------------|---------------------------|-------------------------|
| NAME | PART NUMBER | CATERPILLAR SPECIFICATION | DESCRIPTION |
| Hose | 122-6873 | 1E0716 | 25.4 mm (1.0 inch) I.D. |
| Coupling | 124-2123 | -16 ORFS | Female swivel |
| Adapter | 6V-8635 | -16 STOR/ -16 ORFS | Male-X / Male |

Table 12

Remote mounting of the transmission oil filter in a location selected by the OEM is an option. The filter may also be located to facilitate easier maintenance. For remote filter applications, the OEM is responsible for designing a bracket to secure the filter base vertically above the filter element on the vehicle. See **283-4102** Dimension Drawing.

Additional remote oil filter requirements:

- » The hydraulic line used shall have a minimum working pressure rating of 5500 kPa (800 psi) and a temperature rating of -40 °C to 121 °C (-40 °F to 250 °F) or higher.
- » All remote mount fittings should use high temperature fluorocarbon rubber (FKM) O-rings also known by the trade name Viton. These O-rings have a Shore A Durometer hardness of 75-90.
- » The maximum allowable pressure drop per line due to the line length and the fittings is 34 kPa (5 psi). This pressure drop is measured at high idle and during normal operating temperature 80 to 90°C (176 to 194 °F) at the filter outlet pressure test port and the PTO lube and clutch pressure test port that is located on the rear of the transmission. Both lines should be the same length.
- » The remote mount filter shall be located away from the exhaust.
- » The hydraulic line connecting to the remote mount filter shall be properly supported. Minimize bend in the lines.
- » Consider service access to the filter during the design of the bracket and the location of the remote mount filter. Clearance is required to replace filters and to access S-O-S (Service Mark) and pressure test ports.
- » The recommended position of the remote filter base must orient the filter vertically under the filter base.

CX31 TRANSMISSION

POWER TRAIN OIL SYSTEM

Fill Tube

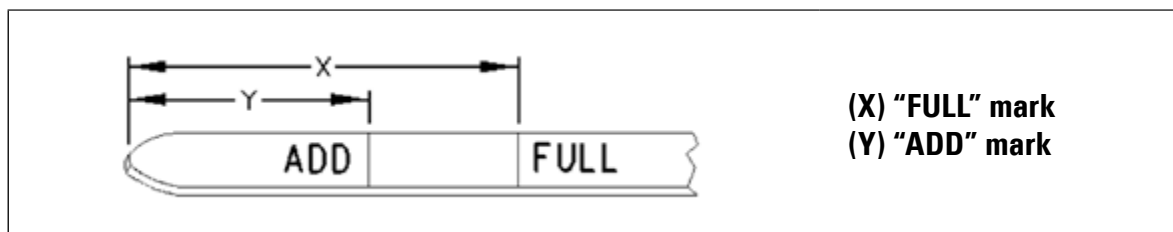

Diagram 17

Refer to the Installation Dimensions Drawing for details on the recommended fill tube geometry and O-ring seal.

Additional Oil fill tube requirements:

- » The fill tube does not require venting.
- » The fill tube must be clean and dry prior to installation to prevent moisture and dirt contamination.
- » Minimize bends required to route the fill tube to an accessible location.
- » The fill tube must be secured to the transmission and the other end should be secured appropriately by the OEM.
- » The fill tube cap must be sealed with elastomeric type seal to prevent moisture and dirt contamination.

Transmission Oil Level (Check)

The transmission oil level is checked under the following conditions:

- » The transmission is at operating temperature.
- » The engine is at low idle.
- » The transmission is in Neutral.
- » The vehicle is on level ground.

Breather

The Cat® CX31 Transmission comes with an installed breather. The purpose of the breather is to balance pressure inside the transmission that can be created during operation. Special care must be exercised not to plug this filter with any type of material (paint, protectant, etc.), and to avoid damage during installation.

CX31 TRANSMISSION

TRANSMISSION GEAR SELECTOR (OPERATOR USAGE OF SHIFT PAD)

The CX 31 Transmission Shift pad is used for entering the desired direction for operation. The shift pad will display N N when in Neutral. When shifted into drive, the shift pad will normally display 6 1. When in reverse, the shift pad will display R R.

Trucks built as of June 2012 may have additional programming that can affect the shift from Neutral. The Park Brake may prevent shifting from Neutral. When enabled, attempting to shift into Drive or Reverse will result in the transmission remaining in Neutral and the left digit of the shift pad will flash.

To shift from Neutral, apply the service brake and release the Park Brake. Select Neutral, and then select the desired range (Drive or Reverse).

CX31 TRANSMISSION

POWER TAKE-OFF (PTO) OPTIONS AND INSTALLATION REQUIREMENTS

All CX31 are capable of driving two side PTOs. The CX31 can be factory ordered with an optional rear PTO. The optional rear PTO can also be installed in the field by removing the rear PTO cover and placing the additional drive shaft and its associated seals and bearings in the transmission. Removing the rear cover plate will allow some transmission oil to drain. Refer to the Disassembly and Assembly manual KENR5090 of parts and specifics. See Illustration 30 for PTO locations.

Bolt on PTO units are available from aftermarket suppliers and can be specified to adapt to a variety of output options. Specifying and designing and installing the PTO devices are the responsibility of the OEM, body builders and the end user.



WARNING: To avoid personal injury due to entanglement with rotating shaft, keep PTO master cover and all power drive system covers in place. Install PTO shaft guard when the system is not in use.

Note: Serious injury can be prevented with proper driveshaft guards. It is the OEM or the auxiliary PTO installer's responsibility to provide guards on exposed rotating parts.

Direction Of Rotation

Engine Rotation SAE J824 - Standard

- » **Counterclockwise as viewed from the flywheel end of the engine**

Transmission Output Rotation

- » **Forward Same as Input (Converter)**
- » **Reverse Opposite of Input**

PTO Rotation

- » **Transmission side PTO drive gear rotates at engine rpm and same direction as transmission input.**
- » **Rear PTO shaft rotates at 1.25 X Engine rpm and in the opposite direction of transmission input.**

CX31 TRANSMISSION

POWER TAKE-OFF (PTO) OPTIONS AND INSTALLATION REQUIREMENTS

Side PTO Torque Limits

| PTO CONFIGURATION | MAX CONTINUOUS TORQUE |
|-------------------------------|-----------------------|
| Single side PTO | 950 N·m (700 lb ft) |
| Multiple PTO total torque (1) | 1627 N·m (1200 lb ft) |

Table 27

(1) Each PTO shall not exceed the single PTO maximum torque.

Transmission PTO Controls

Programmable features, permitting PTO operation under certain parameters, are useful to control PTO operation. These include:

- » PTO operation in Neutral only.
- » PTO engagement below a specific engine speed.
- » Overspeed protection.

PTO Installation Instructions

Follow all installation instructions supplied by the PTO manufacturer.

Side PTO Interface

Refer to the Installation Dimensions Drawing for details on the side mount PTO pad locations and interface.

Side PTO Mounting Bolts

- » M10 x 1.5 externally threaded fastener
- » Minimum fastener Grade 10.9 in accordance with SAE J1199 (1040 MPa min)
- » Minimum quantity of 8 bolts are required to secure the PTO to the transmission. Alignment dowels are optional hardware that may be provided by the PTO supplier.

Side PTO Mounting Bolt Torque

Torque ... 55 ± 5 N·m (41 ± 3.7 lb ft)

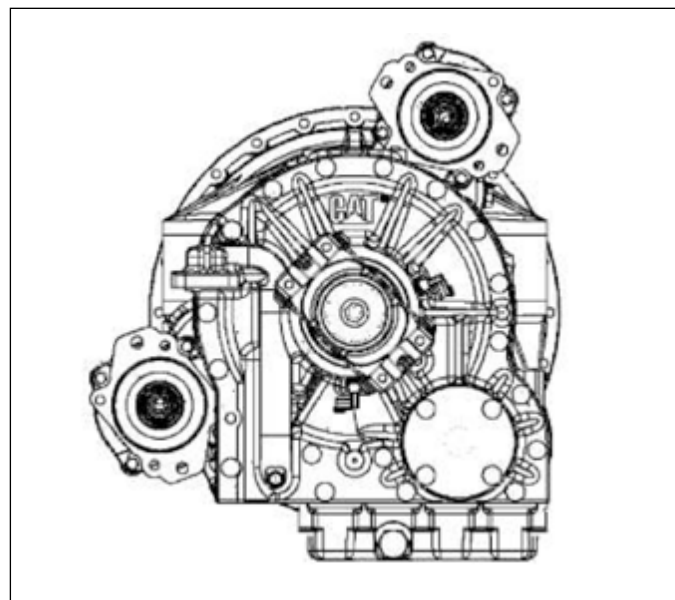

Diagram 30

CX31 TRANSMISSION

POWER TAKE-OFF (PTO) OPTIONS AND INSTALLATION REQUIREMENTS

Side PTO Maximum Bending Moment

From the centerline of the PTO mounting pad: 80 N·m (60 lb ft) maximum (Includes PTO, direct mount pump, and unsupported hydraulic lines).

Side PTO Sealing Requirements

- » The side mounted PTO shall be sealed to the transmission with a rubber coated metal interface gasket (RCM).
- » Do not use sealing compounds. They are usually incompatible with automatic transmission fluid.
- » The RCM gasket supplied by the PTO manufacturer will have the appropriate thickness and tolerance to maintain the required gear center distance. Shimming this PTO is not required.
- » The PTO gasket used to seal the PTO cover is intended to be discarded when installing a side PTO.
- » Paper gaskets shall not be used to seal the PTO to the transmission.

Side PTO Lube and Clutch pressure Ports

- » Two ports are provided, one on the side and one on the rear of the transmission, to provide installation options as required. Refer to 283-4102 Dimension Drawing.
- » Either port may be used regardless of the PTO mounting pad being utilized. For instance, the rear port may be utilized for an 8 o'clock side mount PTO application.

Side PTO Electrical Connections

- » Refer to Special Instruction, REHS2884, "Application and Installation Guide (Electrical)" for specific OEM electric interface definitions and requirement.
- » Refer to the supplier of the PTO attachment for installation instructions of the PTO electrical connections.

CX31 TRANSMISSION

REAR PTO INSTALLATION REQUIREMENTS

Rear PTO Torque limits

Maximum output torque permitted at the rear PTO output coupling.

| PTO CONFIGURATION | MAX CONTINUOUS TORQUE |
|-------------------------------|-----------------------|
| Single side PTO | 1080 N·m (800 lb ft) |
| Multiple PTO total torque (1) | 1627 N·m (1200 lb ft) |

Table 28

(1) Each PTO shall not exceed the single PTO maximum torque.

Rear PTO Interface

Removal of the rear PTO cover after the transmission has been properly filled with oil may cause the loss of some fluid. The amount of oil lost will depend upon the installation angle of the transmission and the surface plane of the vehicle when the cover is removed. (Some PTO component suppliers recommend draining the transmission oil prior to installation of PTO components). Check the transmission oil level after installation of PTO components to insure that any oil lost has been replaced and that the added component did not increase the oil requirements of the transmission. The installation dimensional drawings provide additional specifications for the rear PTO mounting pad.

Note: Rear PTO will accept a 4 bolt SAE J744 “B” pump drive and pilot. A supplier adapter is required to mate with the 17 tooth Cat spline.

Rear PTO Bolt Requirements

- » **M12 x 1.75 externally threaded fastener.**
- » **Minimum fastener Grade 10.9 in accordance with SAE J1199 (1040 Mpa min).**
- » **Minimum quantity of 8 bolts required to secure the PTO to the transmission.**

Rear PTO Mounting Bolt Torque

Torque ... 100 ± 5 N·m (74 ± 3.7 lb ft)

Rear PTO Maximum Bending Moment

From the rear PTO mounting face: maximum bending moment includes PTO, direct mount pump, and unsupported hydraulic lines. Support brackets designed to reduce the bending moment on the rear PTO must insure that the 80 N·m (60 lb ft) limit cannot be exceeded. See Illustration 34 for bracket support locations.

CX31 TRANSMISSION

REAR PTO INSTALLATION REQUIREMENTS

Rear PTO Sealing Requirements

- » The rear PTO is designed for a standard 241, O-ring seal, Cat part number 6V-1197.
- » The O-ring is intended to provide a static radial sealing over the pilot diameter of the unit mating to the rear PTO pad.
- » O-ring Seal material: FKM (Viton).

Rear PTO Lube Port

Same as the side PTO.

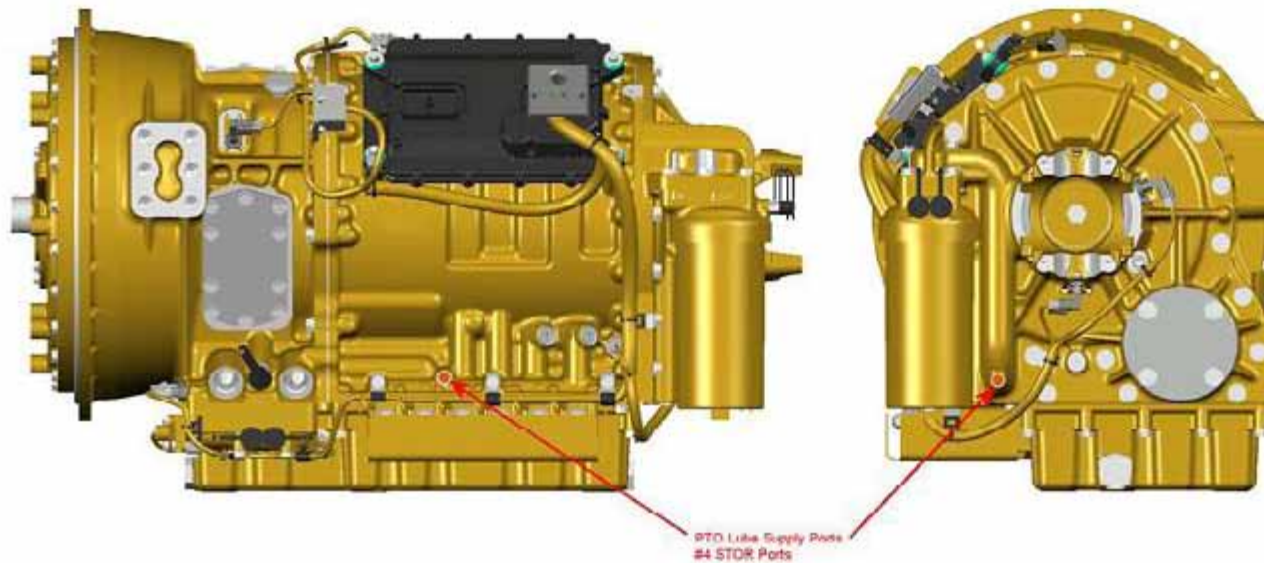

CX31 TRANSMISSION

APPLICATION AND INSTRUCTION FOR DRIVELINE PTO

Introduction

The CX transmission supports Driveline PTO operations without the need for extra hardware or software. Standard software and switch inputs support a “split-shaft Transfer Case” driveline. The transfer case will disconnect from the rear axle (Road Mode) and transmit engine power through the transmission into the pump (Pump Mode). Additional standard features include enhancements to improve shifting between “Road Mode” and “Pump Mode”. For control of the transmission from the pump control station, a secondary shift selector is available. Typical Driveline PTO applications include sewer service systems, hydraulic excavating systems and fire fighting.

CX31 TRANSMISSION

APPLICATION AND INSTRUCTION FOR DRIVELINE PTO

Overview of Basic Operation

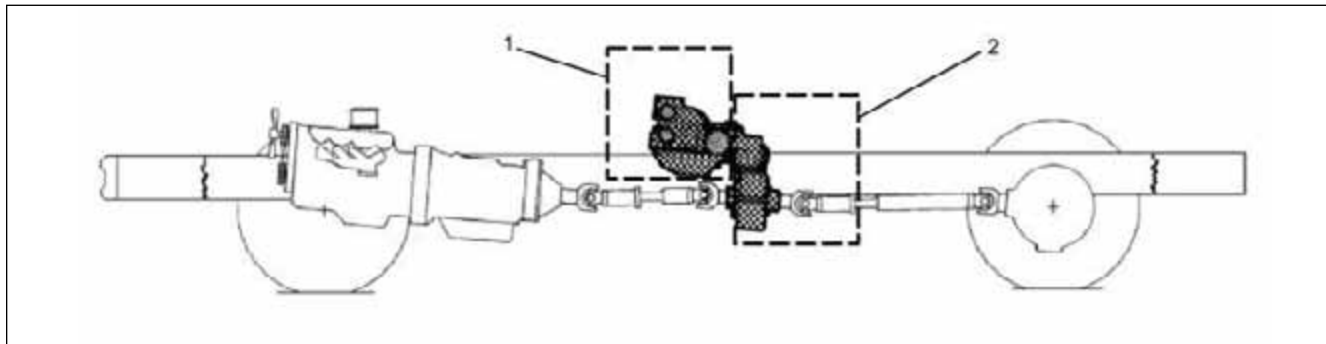

Diagram 1 — Typical transmission driveline configuration for Driveline Pumping

(1) Pump (2) Split Shaft Transfer Case

- 1) Drive the vehicle to the site.
- 2) Set the parking brake and select Neutral.
- 3) Engage the mode for the pump. The mode for the pump disengages the rear axle and the mode for the pump engages the pump.
- 4) Select Drive. The Series CX transmission selects the programmed gear for pumping.
- 5) Accelerate the engine to pumping speed.
- 6) Operate pump system.
- 7) The operation for pumping is complete.
- 8) Return engine to LOW IDLE
- 9) Select NEUTRAL.
- 10) Engage the mode for roading. The mode for roading disengages the pump and the mode for roading engages the rear axle.
- 11) Release the parking brake and drive from the site.

CX31 TRANSMISSION

APPLICATION AND INSTRUCTION FOR DRIVELINE PTO

Chassis Interface for the Transmission Driveline Power Take Off Operation Required Chassis Interface

- » Request switch for the pump mode input
- » Positive pump mode engagement switch input
- » The Gear driver output enables the Ok to pump lamp indicator and is used as one of the interlocks for the OK to pump lamp.

Required Chassis Interface Description

Pump Mode Request Switch Input

The pump mode request switch input tells the Series CX transmission that the vehicle operator has requested the change from propelling the vehicle to pumping mode.

Positive Pump Mode Engagement Switch Input

The positive pump mode engagement switch input tells the Series CX transmission that there has been a successful transition from propel mode into pump mode.

Gear Driver Output

The Gear Driver Output is used to indicate that the transmission has attained the programmed gear for operation of the driveline power take off (DPTO). This output is used as a lamp driver and one of the interlocks in the circuit for OK to Pump.

Optional DPTO Chassis Interface Connections

Parking Brake Switch

A switch actuated by the parking brake should be considered for safe stationary operation of the pump.

Secondary Shift Selector

A secondary shift selector could be included in the vehicle pump station design. A secondary shifter will allow for out of the cab operation, of the transmission during Pumping operations.

CX31 TRANSMISSION

APPLICATION AND INSTRUCTION FOR DRIVELINE PTO

Typical Wiring Diagram for the PTO

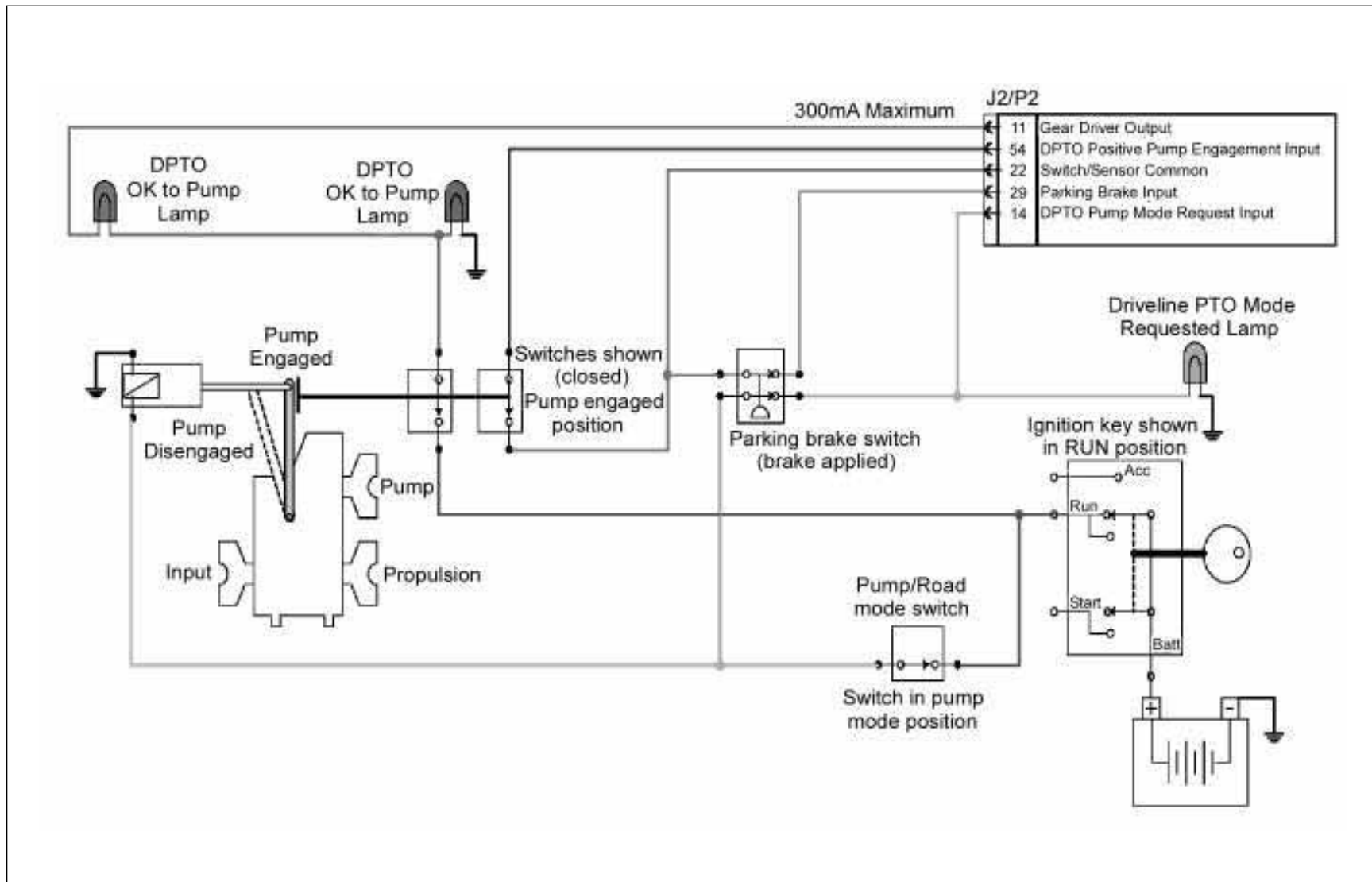

Diagram 2

CX31 TRANSMISSION

APPLICATION AND INSTRUCTION FOR DRIVELINE PTO

Optional Secondary Shift Selector for Pump Station Control of the Transmission

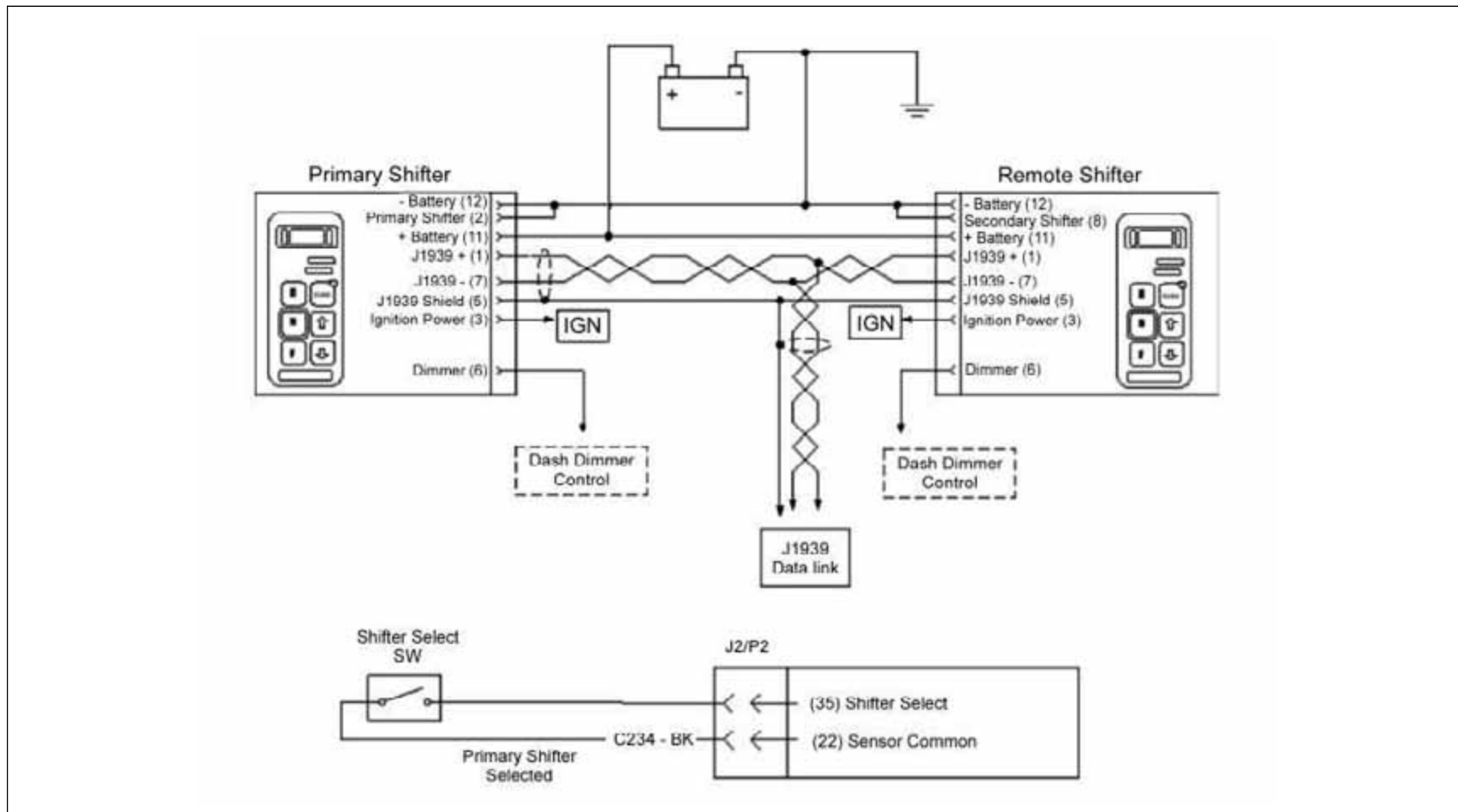

Diagram 3

The option of including a secondary transmission shift selector, allows for transmission shift control from the Pump Control Station. Programming of the Shifter number 2 Configuration parameter to "J1939" and the installation of a switch input at "J2: 35" is required for the remote operation of the shifter. This switch would be interlocked with other circuits in order to prevent the switch input of a "J2: 35" from being activated during operations that do not use the pump mode.

CX31 TRANSMISSION

APPLICATION AND INSTRUCTION FOR DRIVELINE PTO

Programming Parameters to Support Driveline PTO

The following table lists the driveline PTO programmable parameters which are needed to support the operation of the driveline PTO.

| PARAMETER | POSSIBLE SETTING | EXPLANATION |
|--|---|---|
| Driveline PTO Latching Enabled Status | Disabled | OptionalUse this parameter to enable latching of DLPTO function through electrical malfunctions and inadvertent shift pad interaction. |
| Driveline PTO Minimum Engine Speed for Latching | 0 RPM | OptionalThe Driveline PTO Minimum Speed for Latching is used in those cases where it is desired to keep the torque converter and Pump Mode gear engaged during electrical malfunctions or inadvertent shift pad interaction |
| Driveline PTO Minimum Engine Speed for Torque Converter Lockup | 1000 RPM | Recommended settingAllows for compliant engagement of the pump system with the torque converter. unlocked. The torque converter will 'Lock-Up' at the programmed value providing a mechanical connection between the engine and pump. |
| Driveline PTO Inertia Brake Enabled Status | Enabled | OptionalAids in transition from 'pump mode' to 'road mode' by stopping the driveshaft from rotating. |
| Driveline PTO Mode Enabled Gear Configuration | Gear 4 | Required parameter1:1 gear ratio through the transmission |
| Shifter #2 Configuration | J1939 | Secondary shifter is OptionalAllows for a remote shift pad to control the transmission from the pump control station.Requires addition of 'switch to ground' circuit at J2: 35 |
| Auto Neutral Function Enabled Status | Disabled (Set to Enabled as of June 2012) | Recommended settingPrevents disruption of engaging pump mode |
| Parking Brake Input Installation Status | Installed and Neutralized Logic is Enabled (Set to Installed as Default) | Recommended settingAllows for auto shift into Neutral when the Park Brake is applied, then shift into Pump Mode without releasing the Park Brake |

Table 1

Programming Notes

As of June 2012, the PTO switch input (supporting the side and rear mount PTO systems) programming and wiring strategy must be changed in order to program the Driveline PTO parameter ""Driveline PTO Mode Enabled Gear Configuration"" to the desired gear for pumping operation.

First, change the ""PTO Switch Input Configuration"" parameter from ""Switch to Battery 1"" to one of the other switch input options. If the side mount PTO feature is used on this chassis, the wiring must be changed to match the changed programming.

CX31 TRANSMISSION

APPLICATION AND INSTRUCTION FOR DRIVELINE PTO

Choosing the Correct Gear for Pumping Operations

The “Driveline PTO Mode Enabled Gear Configuration” customer parameter is used to select the gear for driveline PTO operation. The correct gear for the desired pump speed will be based on the gear ratio of the transmission. The typical pump operation requires a ratio of 1 to 1 (engine speed to shaft speed of the transmission output). For the CX31 transmissions, Gear 4 provides the 1 to 1 ratio.

| GEAR RATIOS | | |
|-------------|---------|-------|
| | GEAR | RATIO |
| CX31 | Reverse | 3.97 |
| | 1F | 4.4 |
| | 2F | 2.33 |
| | 3F | 1.53 |
| | 4F | 1 |
| | 5F | 0.72 |
| | 6F | 0.61 |

Table 2

CX31 TRANSMISSION

APPLICATION AND INSTRUCTION FOR DRIVELINE PTO

Torque Converter Lockup Programming

The “Driveline PTO Minimum Engine Speed for Torque Converter Lockup” customer parameter is used to establish the engine speed that the torque converter’s lockup clutch will engage. Engagement of the lock up clutch will increase the efficiency of the overall vehicle system. Cooling requirements of the transmission are also reduced. The transmission, once the initial DPTO range is attained, will engage the torque converter lockup clutch approximately one second after the programmed speed is exceeded. When engaged, the torque converter lockup clutch will not disengage until the engine speed is 200 rpm less than the programmed speed, or if the engine falls below low idle speed. A typical value for this parameter is 1000 rpm. If required, the torque converter lockup clutch may remain disengaged in order to provide a compliant element in the DPTO system. To prevent the torque converter from engaging, the “Driveline PTO Minimum Engine Speed for Torque Converter Lockup” customer parameter will be programmed to a value beyond the normal driveline PTO operating range.

DPTO Latch Programming

Some applications require the DPTO mode to be disengaged solely based on the engine speed value. This provides a robust system, which once the DPTO is engaged, will continue to function during inadvertent shift selector requests or faults in the DPTO switch inputs. The “Driveline PTO Latching Enabled Status” customer parameter is provided in order to enable or disable the Latch. The “Driveline PTO Minimum Engine Speed for Latching” customer parameter is used to set the engine speed that will cause the transmission to latch the gear for pumping.

NOTICE: Once latched, the transmission will remain in gear until the engine speed is reduced to 200 rpm below the “Driveline PTO Minimum Engine Speed for Latching” programmed speed. The transmission will ignore selecting Neutral from the shift selector, changing the status of the Driveline PTO switch input, the Driveline Engaged switch input, and releasing the parking brake.

Programming of the Inertia Brake

With the transmission in Neutral, the output shaft can continue to rotate after the pumping action is completed and Neutral is selected. With the “Driveline PTO Inertia Brake Enabled Status” programmable parameter programmed to Enabled, the transmission’s internal clutches will act as an inertia brake to stop the output shaft’s rotation. This will aid in shifting back into Road mode.

Gear Driver Output Programming

The “Gear Indicator Enabled Status” must be programmed to same gear as the “Driveline PTO Mode Enabled Gear Configuration” programming. This output will be enabled when the operator has selected “D” on the gearshift selector and the transmission has shifted into the programmed gear for driveline PTO operation. This output will be included in the interlock system for the “OK to Pump” indication circuit.

CX31 TRANSMISSION

APPLICATION AND INSTRUCTION FOR DRIVELINE PTO

Pump Shift Assist

Cat® Series CX transmissions have a feature called Pump Shift Assist that is designed to help in the transition between Road Mode and Pump Mode. In the event that the positive pump engagement circuit (J2: 54) does not close within one second after the DPTO pump mode request circuit (J2:14) is closed, the Cat Series CX transmissions will temporarily apply a small amount of torque to the transmission output shaft. This torque will cause the transmission output shaft to rotate. The rotation will help to engage the internal driveline PTO components. This will assist the driveline PTO device in completing the shift from road to pump mode. If the positive pump engagement circuit does not close within 30 seconds, this torque will be removed and the Pump Shift Assist feature will be deactivated until the DPTO pump request circuit is opened and then closed again.

Typical operation

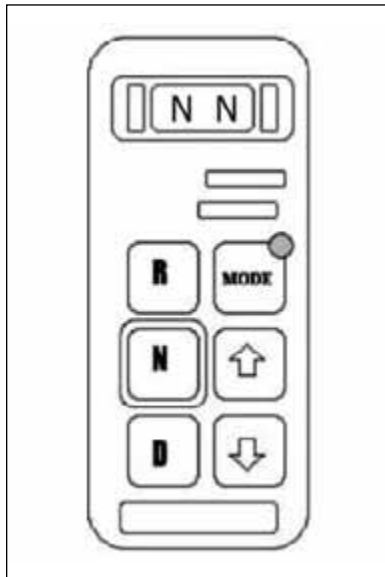

Diagram 4 — Gearshift Selector Display

CX31 TRANSMISSION

APPLICATION AND INSTRUCTION FOR DRIVELINE PTO

- 1) The Operator Selects Neutral and engages the Parking Brake.

| STEP | GEAR SELECTED | SHIFT SELECTOR DISPLAY | VEHICLE SWITCHES | | | PUMP MODE REQUEST LAMP | POSITIVE PUMP ENGAGE LAMP | OK TO PUMP LAMP | INERTIA BRAKE |
|------|---------------|------------------------|--------------------------------|----------------------------|--------------------------|------------------------|---------------------------|-----------------|---------------|
| | | | Pump Mode Request switch J2:14 | Positive Pump Engage J2:54 | Gear Driver Output J2:11 | | | | |
| 1 | N | NN | Off | Off | Off | Off | Off | | Off |

Table 3

- 2) The Operator should Select the Pump Mode. The operator is to move the selector from Road Mode to Pump Mode.

| STEP | GEAR SELECTED | SHIFT SELECTOR DISPLAY | VEHICLE SWITCHES | | | PUMP MODE REQUEST LAMP | POSITIVE PUMP ENGAGE LAMP | OK TO PUMP LAMP | INERTIA BRAKE |
|------|---------------|------------------------|--------------------------------|----------------------------|--------------------------|------------------------|---------------------------|-----------------|---------------|
| | | | Pump Mode Request switch J2:14 | Positive Pump Engage J2:54 | Gear Driver Output J2:11 | | | | |
| 3 | N | NN | On | On | Off | On | On | Off | Off |

Table 4

- 3) At the mechanical completion of the split shaft PTO system shift into pump mode from road mode the positive pump engagement switch should be enabled.

| STEP | GEAR SELECTED | SHIFT SELECTOR DISPLAY | VEHICLE SWITCHES | | | PUMP MODE REQUEST LAMP | POSITIVE PUMP ENGAGE LAMP | OK TO PUMP LAMP | INERTIA BRAKE |
|------|---------------|------------------------|--------------------------------|----------------------------|--------------------------|------------------------|---------------------------|-----------------|---------------|
| | | | Pump Mode Request switch J2:14 | Positive Pump Engage J2:54 | Gear Driver Output J2:11 | | | | |
| 2 | N | NN | On | Off | Off | On | Off | Off | Off |

Table 5

CX31 TRANSMISSION

APPLICATION AND INSTRUCTION FOR DRIVELINE PTO

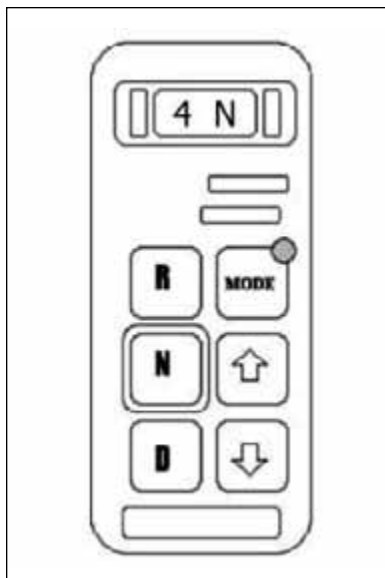

Diagram 5

Select forward gear for pumping operation. Once the mechanical shift into pump mode has been accomplished, the operator can now request the programmed forward gear for pumping.

| STEP | GEAR SELECTED | SHIFT SELECTOR DISPLAY | VEHICLE SWITCHES | | | PUMP MODE REQUEST LAMP | POSITIVE PUMP ENGAGE LAMP | OK TO PUMP LAMP | INERTIA BRAKE |
|------|---------------|------------------------|--------------------------------|----------------------------|--------------------------|------------------------|---------------------------|-----------------|---------------|
| | | | Pump Mode Request switch J2:14 | Positive Pump Engage J2:54 | Gear Driver Output J2:11 | | | | |
| 4 | D | 4N | On | On | Off | On | On | Off | Off |

Table 6

CX31 TRANSMISSION

APPLICATION AND INSTRUCTION FOR DRIVELINE PTO

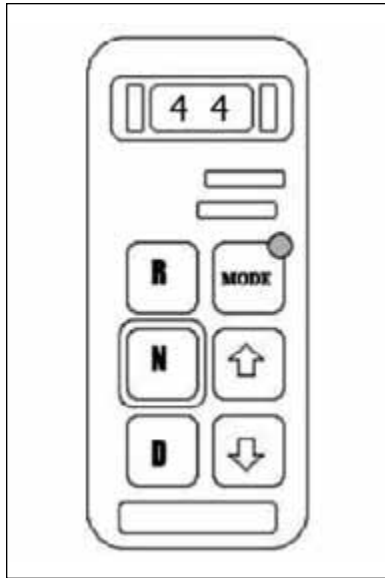

Diagram 6

- 4) After the transmission has completed the shift into the gear for pump mode, the programmed gear driver output circuit will be enabled.

| STEP | GEAR SELECTED | SHIFT SELECTOR DISPLAY | VEHICLE SWITCHES | | | PUMP MODE REQUEST LAMP | POSITIVE PUMP ENGAGE LAMP | OK TO PUMP LAMP | INERTIA BRAKE |
|------|---------------|------------------------|--------------------------------|----------------------------|--------------------------|------------------------|---------------------------|-----------------|---------------|
| | | | Pump Mode Request switch J2:14 | Positive Pump Engage J2:54 | Gear Driver Output J2:11 | | | | |
| 5 | D | 44 | On | On | On | On | On | On | Off |

Table 7

CX31 TRANSMISSION

APPLICATION AND INSTRUCTION FOR DRIVELINE PTO

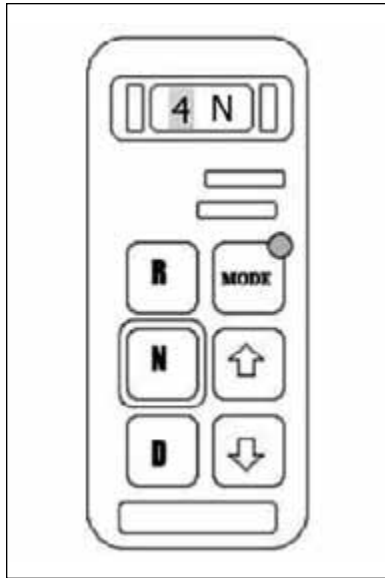

Diagram 7

- 5) When the left digit is flashing, the operator is required to once again select Neutral on the gearshift selector and then ensure that the vehicle is prepared to enter pump mode before shifting back into drive.

Note: The left digit on the shift selector will flash if conditions are not met for DPTO operation or if a switch input inadvertently is opened during pumping operation. If the pump request switch input is closed but other switch input conditions are not met for the pumping operation, the transmission will remain in Neutral and the left digit will flash. If the transmission is in the pump mode operation and a switch input is inadvertently opened, the transmission will shift into Neutral and the left digit will flash.

CX31 TRANSMISSION

APPLICATION AND INSTRUCTION FOR DRIVELINE PTO

| STEP | GEAR SELECTED | SHIFT SELECTOR DISPLAY | VEHICLE SWITCHES | | | PUMP MODE REQUEST LAMP | POSITIVE PUMP ENGAGE LAMP | OK TO PUMP LAMP | INERTIA BRAKE |
|------|---------------|------------------------|--------------------------------|----------------------------|--------------------------|------------------------|---------------------------|-----------------|---------------|
| | | | Pump Mode Request switch J2:14 | Positive Pump Engage J2:54 | Gear Driver Output J2:11 | | | | |
| 6 | D | 4N | On | Off | Off | On | Off | Off | Off |

Table 8

- 6) Ending Pump Operation – To end the Pump Mode the operator is to select Neutral on the gearshift selector, then turn the pump request switch to Off and then select Road Mode. If Programmed, the inertia brake will engage in order to stop the tail shaft of the transmission from rotating to allow for easy shift into Road Mode.

| STEP | GEAR SELECTED | SHIFT SELECTOR DISPLAY | VEHICLE SWITCHES | | | PUMP MODE REQUEST LAMP | POSITIVE PUMP ENGAGE LAMP | OK TO PUMP LAMP | INERTIA BRAKE |
|------|---------------|------------------------|--------------------------------|----------------------------|--------------------------|------------------------|---------------------------|-----------------|---------------|
| | | | Pump Mode Request switch J2:14 | Positive Pump Engage J2:54 | Gear Driver Output J2:11 | | | | |
| 7 | N | NN | Off | Off | Off | Off | Off | Off | Off |

Table 9

CX31 TRANSMISSION

Wiring and Connections Connectors

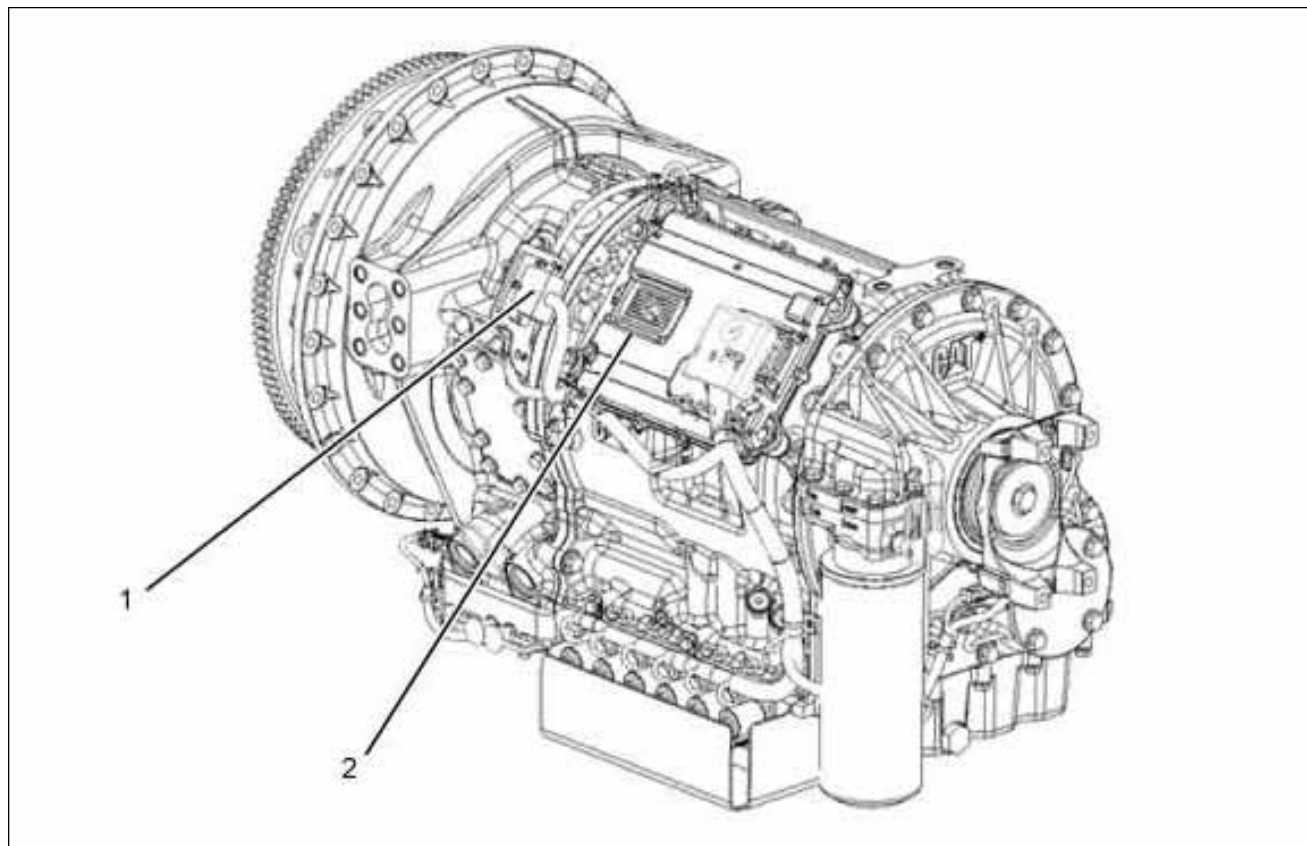

Diagram 8 — Series CX31 Transmission

- » (1) 24 Pin Connector J3
- » (2) 70 Pin Connector J2

Two machine interface connectors are required for the vehicle. The 24-pin connector has the ignition switch and battery connections. The 70-pin ECU J2 terminal connector has the remaining switch inputs and J1939 data link connections. Please refer to Special Instruction, REHS2884, “Application and Installation Guide (Electrical) for the CX31 On-Highway Transmission from your local Cat® Dealer”.

[↶ return to table of contents](#)

CX31 TRANSMISSION

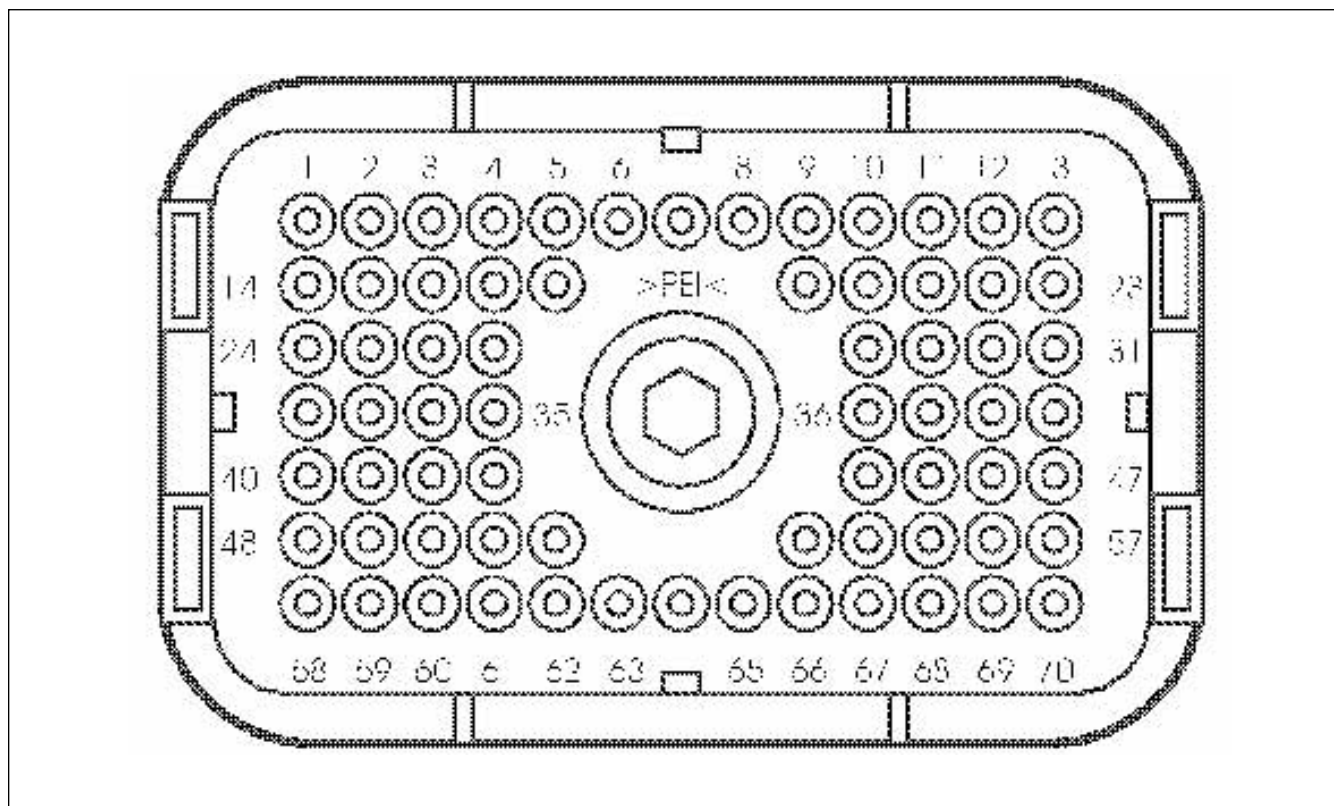

Diagram 9 — 70 Pin ECU J2 Terminal Connector

The connector for the chassis is the 70 pin ECU J2 terminal connector. **Note:** Caterpillar does not recommend the use of nonconductive grease with this connector.

Torque of the Allen Head Bolt for the Terminal Connector

The torque for the Screw of the 70 Terminal ECU J2 Connector is 6 ± 1 N·m (53 ± 8.9 lb in). The screw requires a 4 mm (5/32 inch) hex wrench.

Size of the Wire Gauge

The maximum wire size is #14 AWG SAE J1128 type GXL. Recommended wire size is #16 or #18 AWG SAE J1128 type SXL, #16 or #18 AWG SAE J1128 type GXL or a wire of equivalent gauge and diameter.

CX31 TRANSMISSION

Wire Insulation and Size Range

The diameter of the wire insulation must be within the following ranges in order to ensure proper sealing.

| WIRE TYPE | WIRE GAUGE | DIAMETER OF THE INSULATION |
|-----------|------------|---|
| GXL | 14 | 2.90 mm to 3.18 mm (0.114 inch to 0.125 inch) |
| | 16 | 2.44 mm to 2.85 mm (0.096 inch to 0.112 inch) |
| | 18 | 2.26 mm to 2.49 mm (0.089 inch to 0.098 inch) |
| SXL | 16 | 2.95 mm to 3.33 mm (0.116 inch to 0.131 inch) |
| | 18 | 2.62 mm to 3.00 mm (0.103 inch to 0.118 inch) |

Table 10

Part Numbers for Connectors, Sockets and Plugs

| REQUIRED PARTS FOR THE TERMINAL CONNECTOR | | | |
|--|---|--------------------------|-------------------------|
| DESCRIPTION | USAGE | VENDOR PART NUMBER | CATERPILLAR PART NUMBER |
| 70 Terminal connector | ECU Harness of the Vehicle | Amp 776241-6 | 147-1446 |
| AMP Gold Socket Contact Stamped formed | #16 & #18 AWG SXL and #14, #16 and #18 AWG GXL wire | Amp 638090-1 | 126-1766 |
| Deutsch Gold Socket Contact machined for field service | #14 AWG SXL and #14 AWG GXL wire | Deutsch 0462-209-1631 | 126-1768 |
| Deutsch Gold Socket Contact machined for field service | #16 & #18 AWG SXL and #16 and #18 AWG GXL wire | Deutsch 0462-201-1631 | 9X-3402 |
| Sealing Plug #14 - 18 AWG | Sealing Unused Cavities of the Connector | PEI Genesis 225-0093-000 | 9G-3695 |
| Sealing Plug #14 - 18 AWG | Sealing Unused Cavities of the Connector | Deutsch 11-4017 | 8T-8737 |

Table 11

Guidelines for the Installation of the Connector Socket

It is critical that the harness supplier use the correct crimp tools and tool calibration set up procedures when installing AMP and Deutsch connector terminals. The following tables indicate the tooling for crimping, the criteria for go or no go, and the dimensions for crimping of each contact for the wire combination.

Note: AMP 776093-1 Stamped and Formed Socket with #16 and #18 AWG SXL wire or with #14, #16 or #18 AWG GXL wire is a Caterpillar part number 126-1766 Connector Socket.

CX31 TRANSMISSION

| WIRE TYPE | WIRE GAUGE | HEIGHT OF THE CRIMP | WIDTH OF THE CRIMP |
|-----------|------------|---|-----------------------|
| GXL | 14 | 1.63 ± 0.05 mm (0.064 ± 0.002 inch) | 2.5400 mm (0.10 inch) |
| | 16 | 1.4986 ± 0.0508 mm (0.059 ± 0.002 inch) | 2.5400 mm (0.10 inch) |
| | 18 | 1.3716 ± 0.0508 mm (0.054 ± 0.002 inch) | 2.5400 mm (0.10 inch) |
| SXL | 16 | 1.3716 ± 0.0508 mm (0.054 ± 0.002 inch) | 2.5400 mm (0.10 inch) |
| | 14 | 1.4986 ± 0.0508 mm (0.059 ± 0.002 inch) | 2.5400 mm (0.10 inch) |

Table 12

Note: The height of the crimp for the insulation barrel of the AMP 776093-1 stamped and formed sockets must be set according to the diameter of the insulation. The width of the crimp for all wire insulation is 3.68 mm (0.145 inch) maximum.

| DEUTSCH 0462-209-1631 SOLID SOCKET WITH #14 AWG WIRE (CAT PART NUMBER 126-1768 CONNECTOR SOCKET) | | | | |
|---|-----------|---------|------------------------|------------------------|
| OPTIONS FOR CRIMP TOOLS | DIE | LOCATOR | GO IN INCHES | NO GO IN INCHES |
| Deutsch Hand Tool HDT-48-00 | N/A | N/A | 1.3208 mm (0.052 inch) | 1.4478 mm (0.057 inch) |
| PICO Model 400 | 414DA-16N | 4301-16 | 1.0922 mm (0.043 inch) | 1.2700 mm (0.050 inch) |

Table 13

| DEUTSCH 0462-201-1631 SOLID SOCKET WITH #16 AND #18 AWG WIRE (CAT PART NUMBER 9X-3402 CONNECTOR SOCKET) | | | | |
|--|-----------|---------|------------------------|------------------------|
| OPTIONS FOR CRIMP TOOLS | DIE | LOCATOR | GO IN INCHES | NO GO IN INCHES |
| Deutsch Hand Tool HDT-48-00 | N/A | N/A | 1.1430 mm (0.045 inch) | 1.2700 mm (0.050 inch) |
| PICO Model 400 | 414DA-16N | 4301-16 | 1.0922 mm (0.043 inch) | 1.2700 mm (0.050 inch) |

Table 14

CX31 TRANSMISSION

SEALING PLUGS

Sealing Plugs

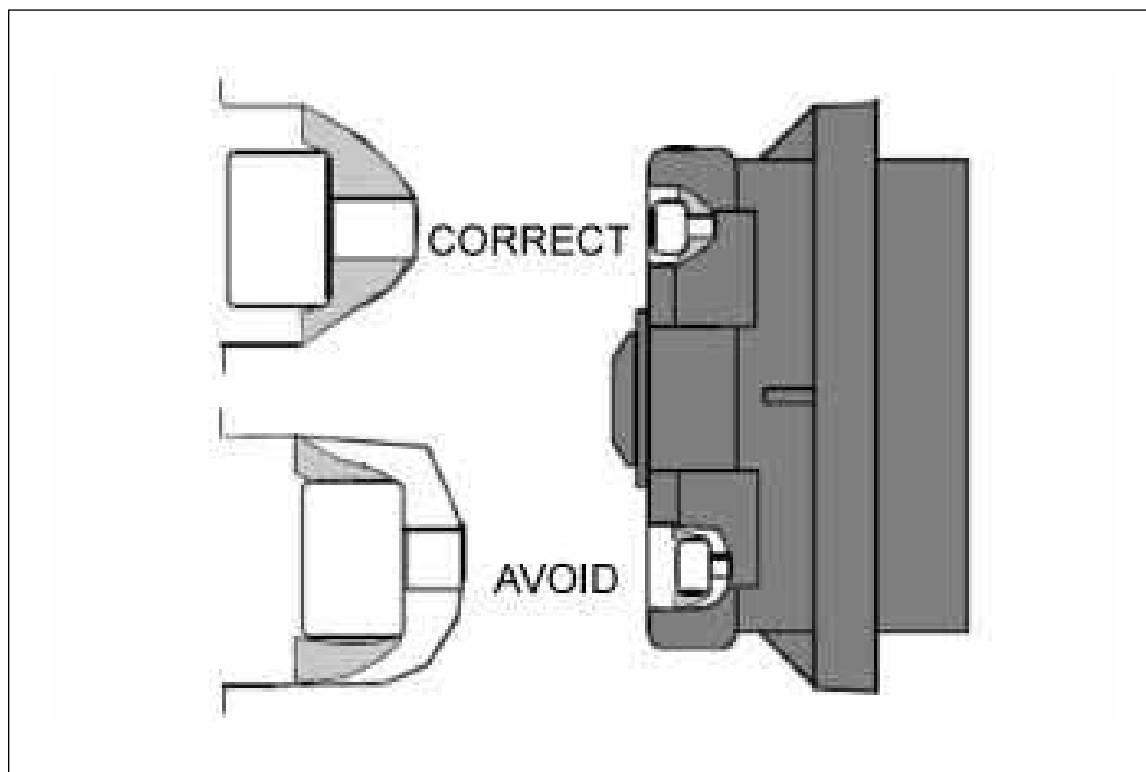

Diagram 10 — Location of the Unused Connector Plug

Caterpillar requires sealing plugs for all unused connector cavities. Two options are available. Either the Deutsch 114017 (Cat part number **8T-8737** Seal Plug) or PEI Genesis 225-0093-000 (Cat part number **9G-3695** Plug) sealing plugs can be used. Correct installation of either of these cavity plugs is critical to maintaining integrity of the sealing surface for the remaining connectors. Illustration 11 indicates the correct insertion of the plug. The plug cap is designed to rest against the seal. The plug cap is not designed to be inserted into the hole in the seal.

CX31 TRANSMISSION CIRCUITS

Requirements for the Current of the Circuit

Switch Circuits

Switch circuits require less than 20 mA. The required minimum size of wire is 18 gauge. This ensures proper sealing at the ECM connector.

Lamp Circuits of the ECM

The Gear Indicator Output (J2: 11), the Speed Enabled Output (J2: 13), The Check Transmission Lam (J2: 9) and the Warning Lamp out (J2: 12) will each drive a maximum of 300 mA. The required minimum size of wire is 18 gauge. This ensures proper sealing at the ECM connector. The ECM provides a ground circuit to a lamp or relay. The other side of the lamp or relay must be connected to the positive side of the battery.

Note: These are incandescent lamp drivers. LEDs may require loading resistors to prevent the LED from glowing when the output is disabled. All inductive loads are required to include reverse voltage suppression.

Support of the Data Link for the Vehicle

The Series CX transmissions support both J1939 and J1587 data links, broadcasting information regarding diagnostics, temperature and actual gear. Additional information is available in publication Special Instruction, REHS2884, "Application and Installation Guide (Electrical) for the CX28, CX31, and CX35 On-Highway Transmissions".

Note: The vehicle must not be equipped with any component that uses Source Address 0x05, or 0x06 except for Caterpillar approved shifter modules.

CX31 TRANSMISSION

ADDITIONAL CX31 FEATURES

Note: Additional feature and programming information is available in Caterpillar Publications
REHS2884
WEGT1000

The CX transmission has a variety of features available for chassis interaction. The feature includes:

- » Power Take Off (PTO) to support hot shift PTO systems
 - » Ranges for Engagement and Operation tied to speeds and gear
- » Vehicle Speed limit enabled/disabled with a switch inputPositive pump mode engagement switch input
- » Directional Shift Inhibit
- » Neutral To Gear Inhibit:
- » Shift Schedule
 - » Change between two programmed schedules
 - » Each shift schedule provides for maximum gear of operation
- » Input to Limit operation to first gear (with or without Reverse)
- » Hold In Gear (make current gear max gear)
- » Neutral to Gear Inhibit
- » Auto Neutral
- » Park Brake single Neutralization
- » Lamp/Relay drivers tied to:
 - » Gear
 - » Speed (engine, Eng with PTO, Driveshaft)

Note: Additional feature and programming information is available in Caterpillar Publication REHS2884

CX31 TRANSMISSION

ADDITIONAL CX31 FEATURES

Vehicle Speed Limit Enabled/Disabled with a Switch Input

Available in July, 2012. Transmission built before July, 2012 will require updated software.

When the Switch Circuit is OPEN, the vehicle's ground speed will be limited to the programmed value.

Switch to Group input @ J2: 24

| PARAMETER | OTIONS |
|-------------------------------------|-----------------------------|
| User Defined Machine Speed Limit #2 | 0 - 127 mph (Default = 127) |

Directional Shift Enable/Disable

Transmission will block programmed range requests when switch circuit is OPEN.

Switch to Group input @ J2: 31

| PARAMETER | OTIONS |
|--|--|
| Direction Inhibit Function Configuration | Disabled, Enabled for Forward, Enabled for Forward and Reverse, Enabled For Reverse |

Neutral to Gear Inhibit

The Neutral to Gear Inhibit feature is used to prevent a shift from neutral as long as the switch input is OPEN.

Switch to Group input @ J2: 31

| PARAMETER | OTIONS |
|--|--|
| Neutral to Gear Inhibit Funtion Configuration | Disabled (Default), Enabled for Forward, Enabled for Forward and Reverse, Enabled For Reverse |

CX31 TRANSMISSION

ADDITIONAL CX31 FEATURES

Shift Schedule

- » Four shift schedules are available
- » Switching between 2 shift schedules is allowed
- » Maximum gear for operation is available for both primary and secondary shift schedules

This feature allows for selecting the programmed desired shift schedule and associated maximum gear. The shift pad's Mode Button is the default input. An optional chassis based switch input is available to enable the alternate shift schedule with its programmed maximum gear. When programmed to "Switch To Ground", a Closed switch circuit at J2: 34 will enable the alternate shift schedule.

| PARAMETER | POSSIBLE SETTING |
|---|---|
| Transmission Default Shift Schedule configuration | Economy 1, Economy 2, Performance 1, Performance 2 |
| Transmission Default Maximum Gear Configuration | Gear 1 - 6 |
| Transmission Alternate Shift Schedule configuration | Economy 1, Economy 2, Performance 1, Performance 2 |
| Transmission Default Maximum Gear Configuration | Gear 1 - 6 |
| Economy Mode Input Configuration | 1939, Not Configured, Switch to Ground |

CX31 TRANSMISSION

ADDITIONAL CX31 FEATURES

Limit Operation to First Gear (with or without Reverse)

The Quick Gear Limit Feature is available to limit transmission operation to gear 1. Additional aspects of this feature allow for blocking shifts into Reverse while the feature is active. The programmed Open switch Circuit at J2: 26 will enable the feature.

| PARAMETER | OTIONS |
|---------------------------------------|--|
| Quick First Gear Limit Configuration | Disabled, Enabled to First Gear and Do Not Lock Out Reverse, Enabled to First Gear and Inhibit Shifts to Reverse |
| Quick Gear limit Switch Configuration | Mode Button, Switch to Ground |

Hold in Gear (make current gear max gear)

The Hold in Gear feature allows for making the current gear the maximum gear. Once enabled, the transmission will downshift normally but will be limited to the selected gear as the new maximum gear for vehicle operation.

The feature switch input options include a switch to ground at J2: 55 and the shift pad Mode Button (J1939 option). The switch to ground input is a momentary switch (door bell) type.

| PARAMETER | OTIONS |
|-----------------------------------|---------------------------------------|
| Hold Function Input Configuration | J1939 (Mode Button), Switch To Ground |

CX31 TRANSMISSION

ADDITIONAL CX31 FEATURES

Auto Neutral

The Auto Neutral feature is tied to the Park Brake as of June 2012. Applying the Park brake will force the transmission into and will then Hold in Neutral until the Park Brake is released, Neutral is reselected and then the desired gear is selected on the shift pad. This feature may be reprogrammed to meet customer or chassis system requirements.

The available switch inputs to control Auto Neutral include the Park Brake, single (J2: 40) and dual switch to ground (J2: 40, J2: 41) inputs. Open switch circuits cause the transmission to shift into and stay in Neutral.

The following table lists some of the Auto Neutral parameters

| PARAMETER | OTIONS |
|---|--|
| Auto Neutral Function Enabled Status | Disabled, Enabled |
| Auto Neutral Switch Input Configuration | Switch to Ground, Dual Switch to Ground, Parking Brake |

Park Brake Single Neutralization

The Park Brake Single neutralization feature is similar to the Auto Neutral feature. There are fewer options and only the park Brake input circuit is used.

To use the Park Brake Single Neutralization feature, reprogram the Auto Neutral feature to a different switch input.

The Park Brake Installation Status parameter is used to enable this feature. When programmed to the Installed and Neutralizer is Enabled option, Transitioning the Parking Brake control from OFF to ON after the vehicle has come to a complete stop (zero vehicle speed), the transmission will shift into Neutral. Once in Neutral, the right digit on the shift selector will indicate Neutral. The Desired Gear, left digit on the shift pad, will flash. This indicates to the operator that Neutral re-selecting Neutral is required to shift into the desired range. The transmission will not automatically shift back into the previous range.

This feature should be considered when using the Drive Line PTO feature as the transmission will shift into gear if the park Brake is enabled.

| PARAMETER | OTIONS |
|---|--|
| Parking Brake Input Installation Status | Installed (default), Installed and Neutralizer Logic is Enabled, Not Installed |

CX31 TRANSMISSION

ADDITIONAL CX31 FEATURES

Output Drivers

Gear Driver Output

The Gear Enabled Output Driver provides an interface tied to a programmed gear or range of gears. The output at J2: 11 is a 300mA driver providing a connection to ground. The output will turn OFF if overloaded with no diagnostic reference.

| PARAMETER | OTIONS |
|---------------------------------------|-------------------|
| Gear Indicator Reverse Enabled Status | Enabled, Disabled |
| Gear Indicator Neutral Enabled Status | Enabled, Disabled |
| Gear Indicator 6F Enabled Status | Enabled, Disabled |
| Gear Indicator 5F Enabled Status | Enabled, Disabled |
| Gear Indicator 4F Enabled Status | Enabled, Disabled |
| Gear Indicator 3F Enabled Status | Enabled, Disabled |
| Gear Indicator 2F Enabled Status | Enabled, Disabled |
| Gear Indicator 1F Enabled Status | Enabled, Disabled |

Speed Enabled Output

The Speed Enabled Output Driver provides an On/Off interface related to the programmed speed. The output at J2: 13 is a 300mA driver providing a connection to ground. The output will turn OFF if overloaded with no diagnostic reference

When programmed to “PTO Engine Speed”, the feature requires that the transmission PTO Enabled Output be enabled before the considering the programmed engine speed values.

| PARAMETER | OTIONS |
|-----------------------------------|---|
| Speed Enabled OutputConfiguration | Disabled, Engine Speed, PTO Engine Speed, Transmission Output Speed (Driveshaft RPM) |
| Speed Enable Output Turn On Speed | 0-5000 RPM |
| Speed Enable Turn Off Speed | 0-5000 RPM |

CX31 TRANSMISSION

ADDITIONAL CX31 FEATURES

CX31 ECM Connection Points

Note: All inputs are referenced to ground (J2: 22) EXCEPT for J2: 14 which is Switch to battery.

| 70-PIN CONNECTOR | FEATURE INTERFACE |
|------------------|--------------------------------|
| J2-6 | PTO Enable Output |
| J2-11 | Gear Driver Output |
| J2-13 | Speed Enable Output |
| J2-15 | Switch to Battery #1 |
| J2-19 | Output Speed Driver |
| J2-22 | Switch Return |
| J2-26 | Quick Gear Limit Input |
| J2-29 | Park Brake |
| J2-30 | Neutral to Gear Inhibit Input |
| J2-31 | Direction Inhibit Switch Input |
| J2-34 | Economy Mode Switch Input |
| J2-35 | Shift Selector Input |
| J2-36 | Service Brake Switch Input |
| J2-40 | Auto Neutral Input #1 |
| J2-41 | Auto Neutral Input #2 |
| J2-46 | PTO On/Off #1 |
| J2-47 | PTO On/Off #2 |
| J2-54 | Driveline PTO Engaged Input |
| J2-55 | Hold Gear |

CX31 TRANSMISSION

Recommendations for Harness Routing

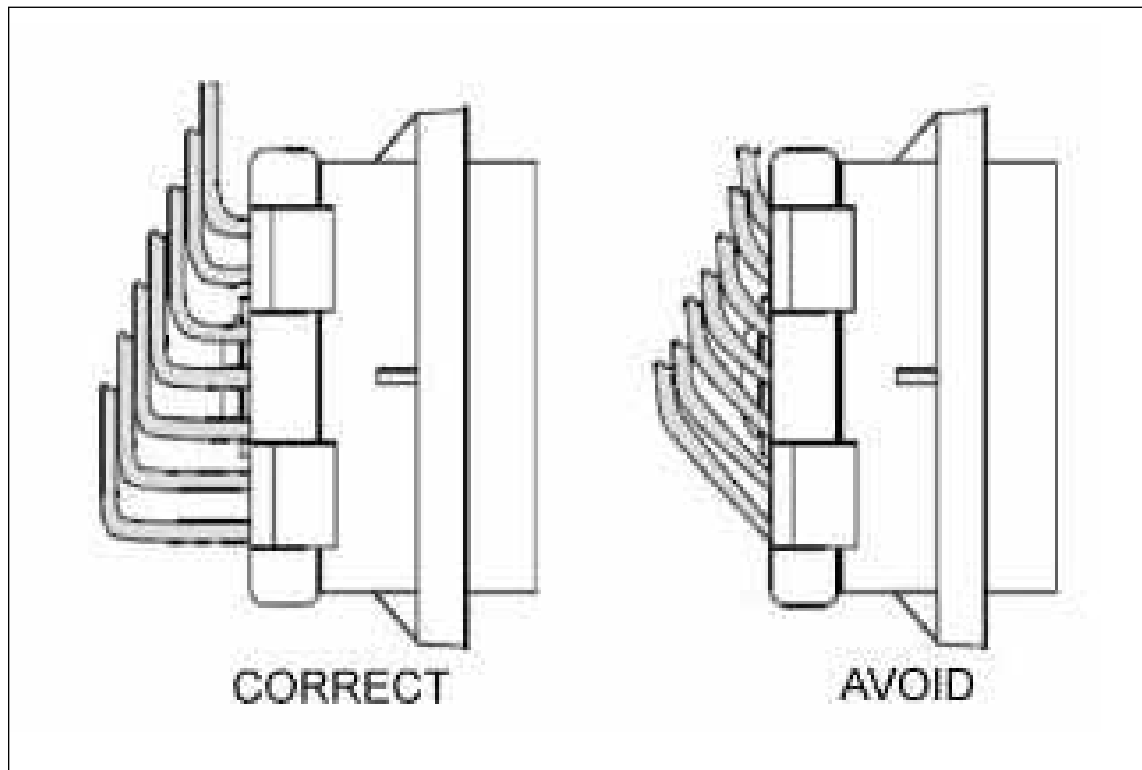

Diagram 11

Ensure that the connector seals are not stressed when you route the harness. The harness can not curve too close to the connector. Refer to Illustration 12. This applies to routing of OEM lines on or near the engine harness and the OEM ECU connector. When the harness curves too close to the connector, the connector seal is stretched away from the wire. The stretched seal provides a gap. Moisture can enter the gap. The wire routing should exit perpendicular to the connector before curving. The bend of harness bundle should have a radius of 2 times the diameter of the harness. In order to provide the correct bend radius for the wiring harness, Caterpillar recommends that the original equipment manufacturer form the harness. This will ensure the connector seal. Also, this can prevent abrasion of the harness.

CX31 TRANSMISSION

NO BODY BUILDER INTERFACE HARNESS

PTO Clutch Control Circuit
Standard Programming

No Body Builder Interface
Harness

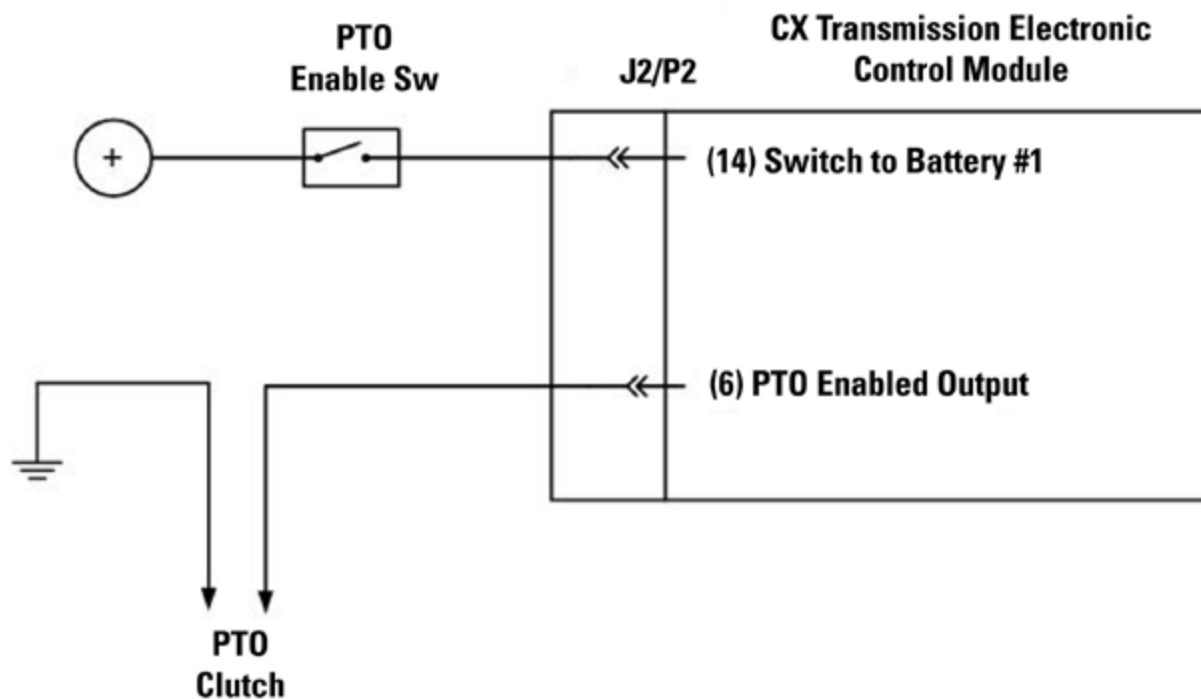

CX31 TRANSMISSION

WITH BODY BUILDER INTERFACE HARNESS

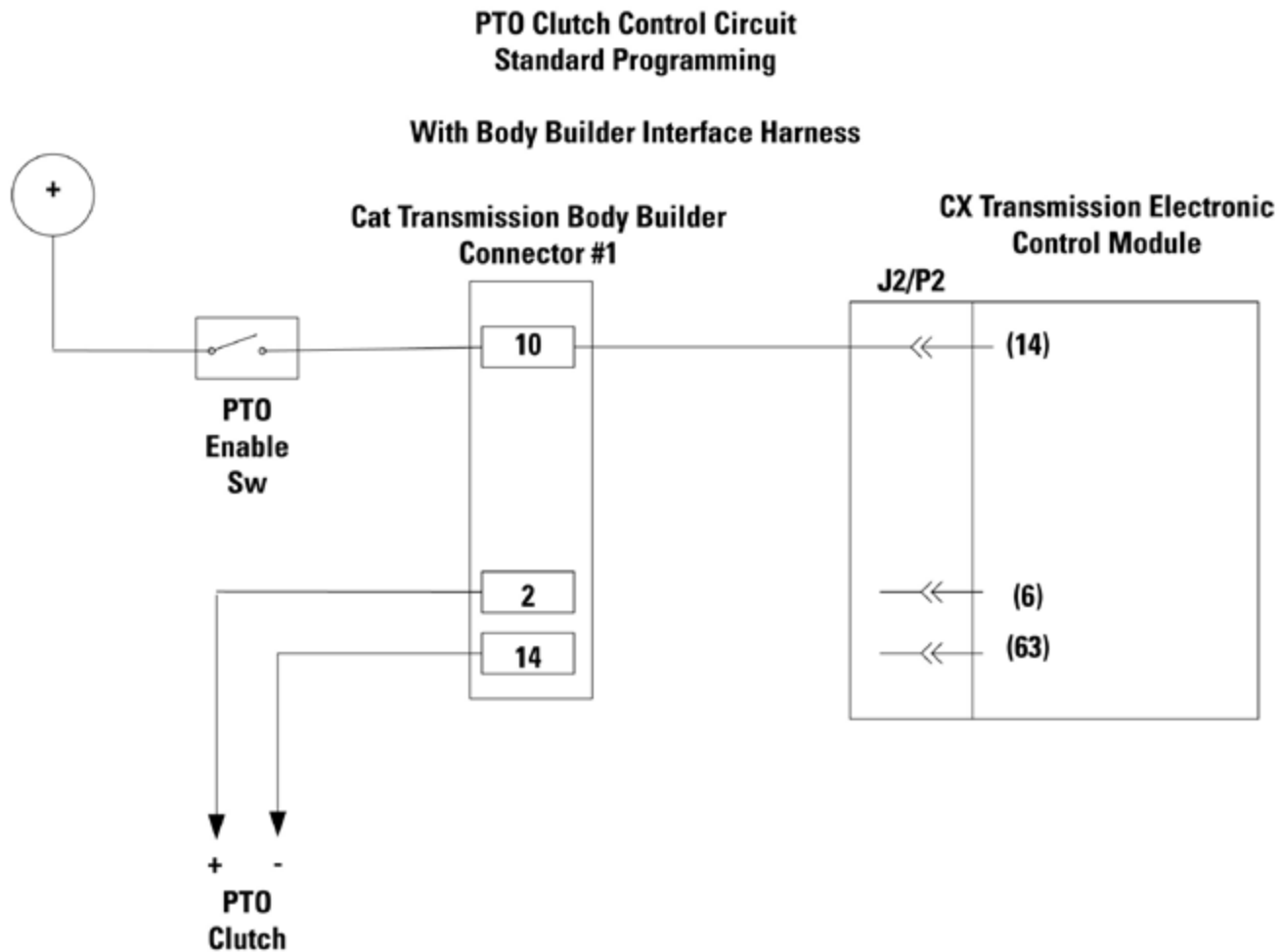

CX31 TRANSMISSION HARNESS

This is the general description on Cat CX31 Automatic transmission wiring harness, Feature Code 13WVM, released in late 2012.

The wiring harness has Two 14 way connectors and one 10 way connector. Mating connectors are installed. Sealing plugs are installed in all unused connector cavities.

The recommended chassis interface wiring size is 16 Ga.

Detailed CX 31 transmission feature descriptions, programming and wiring options are listed in the Caterpillar Special Instruction, media number REHS2884.

The media number for the Electronic Programming Guide is WEGT1000.

| CONNECTOR PART NUMBERS | | | |
|-----------------------------|---|-------------------|------------------|
| HARNESS CONNECTOR | PIN/SOCKET | MATING PIN/SOCKET | MATING CONNECTOR |
| 3962898 (9205) 14 Pin | 3962932 Female | 3962936 Male | 3962934 |
| | 3962931 Female Cavity 8 & 9 (14AWG) | | |
| 3962934 (7206) 14 Pin | 3962935 Male | 3962932 Female | 3962898 |
| 3962961 (7207) 10 Pin | 3962932 Female | 3962936 Male | 4331000 |
| | 3962931 Female Cavity 6 (14AWG) | | |

Mating connector pins/sockets support 14 - 16 Ga wire.

CX31 TRANSMISSION HARNESS

| GENERAL SIGNALS CONNECTOR #1 (HARNESS CONNECTOR 7205) | | | | |
|--|---------------------------------|---------|---------------------------|---|
| DESCRIPTION | BODY BUILDER CONNECTOR POSITION | CIRCUIT | TRANS CONNECTOR POSITION | INPUT/OUTPUT DESCRIPTION |
| Vehicle Speed Limit Enable Sw | 1 | VD92B | J2: 24 | Switch to Common |
| PTO Enable Output | 2 | VD92V | J2: 6 | 2A High Side Drive |
| Optional PTO Enable Switch Input #1 | 3 | VD92W | J2: 46 | Switch to Common |
| Switch Return (Common) | 4 | VE92HA | J2: 22 | Switch Return |
| Future | 5 | VD92BB | J2: 25 | Future |
| Future | 6 | VD92Z | J2: 2 | Future |
| Future | 7 | VD92AA | J2: 4 | Future |
| Future | 8 | VD92CC | J3: 2 (24 pin connector) | Future |
| Future | 9 | VD92DD | J3: 20 (24 pin connector) | Future |
| Default PTO enable switch input (Switch to Battery #1) | 10 | VD92S | J2: 14 | Switch to Batter (10 mA) |
| Check Transmission Lamp Output Driver | 11 | VD9TL | J2: 9 | 300 MA Output Low Side (sinking) Driver |
| Transmission Warning Lamp Output Driver | 12 | VD9WL | J2: 12 | 300 MA Output Low Side (sinking) Driver |
| Open | 13 | N/A | N/A | Open |
| PTO Solenoid Return | 14 | VD92RC | J2: 63 | Ground |

CX31 TRANSMISSION HARNESS

| GENERAL SIGNALS CONNECTOR #2 (HARNESS CONNECTOR 7206) | | | | |
|--|---------------------------------|---------|--------------------------|---|
| DESCRIPTION | BODY BUILDER CONNECTOR POSITION | CIRCUIT | TRANS CONNECTOR POSITION | INPUT/OUTPUT DESCRIPTION |
| Gear Driver Lamp Output Driver | 1 | VD92Q | J2: 11 | 300 MA Output Low Side (sinking) Driver |
| Driveline PTO Engaged Sw | 2 | VD92T | J2: 54 | Switch to Common |
| Shift Selector Sw | 3 | VD92R | J2: 35 | Switch to Common |
| Hold Gear Sw | 4 | VD92J | J2: 55 | Switch to Common |
| PTO Enable Switch Input #2 | 5 | VD92X | J2: 47 | Switch to Common |
| Quick Gear Sw | 6 | VD92E | J2: 26 | Switch to Common |
| Neutral To Gear Inhibit Sw | 7 | VD92F | J2: 30 | Switch to Common |
| Direction Inhibit Sw | 8 | VD92G | J3: 31 | Switch to Common |
| Economy Mode Sw (Shift Schedule Select) | 9 | VD92L | J3: 34 | Switch to Common |
| Retarder Shift Point Enable Input Sw | 10 | VD92K | J2: 23 | Switch to Common |
| Auto Neutral Sw #1 | 11 | VD92C | J2: 40 | Switch to Common |
| Auto Neutral Sw #2 | 12 | VD92D | J2: 41 | Switch to Common |
| Speed Enabled Lamp Output Driver | 13 | VD92O | J2: 13 | 300 MA Output Low Side (sinking) Driver |
| Open | 14 | N/A | Open | Open |

CX31 TRANSMISSION HARNESS

| GENERAL SIGNALS CONNECTOR #3 (HARNESS CONNECTOR 7207) | | | | |
|--|---------------------------------|---------|--------------------------|---|
| DESCRIPTION | BODY BUILDER CONNECTOR POSITION | CIRCUIT | TRANS CONNECTOR POSITION | INPUT/OUTPUT DESCRIPTION |
| Minimum Forward Start Gear Sw | 1 | VD92M | J2: 28 | Switch to Common |
| Alternate Start Gear Enabled Lamp Output Drvr | 2 | VD92N | J2: 10 | 300 MA Output Low Side (sinking) Driver |
| Open | 3 | N/A | N/A | Open |
| Future | 4 | VD92P | J2: 32 | Future |
| Open | 5 | N/A | N/A | Open |
| Switch to Battery #3 | 6 | VD92U | J3: 5 | Switch to Battery (10 mA) |
| Open | 7 | N/A | N/A | Open |
| Future | 8 | VD92H | J2: 21 | Future |
| Future | 9 | VD92I | J2: 27 | Future |
| Service Brake (Optional - Body Builder supplied circuitry) | 10 | VD92A | J2: 36 | Switch to Common |

FUEL TANKS

FUEL TANK LOCATION — 60 GALLON (EGR ONLY)

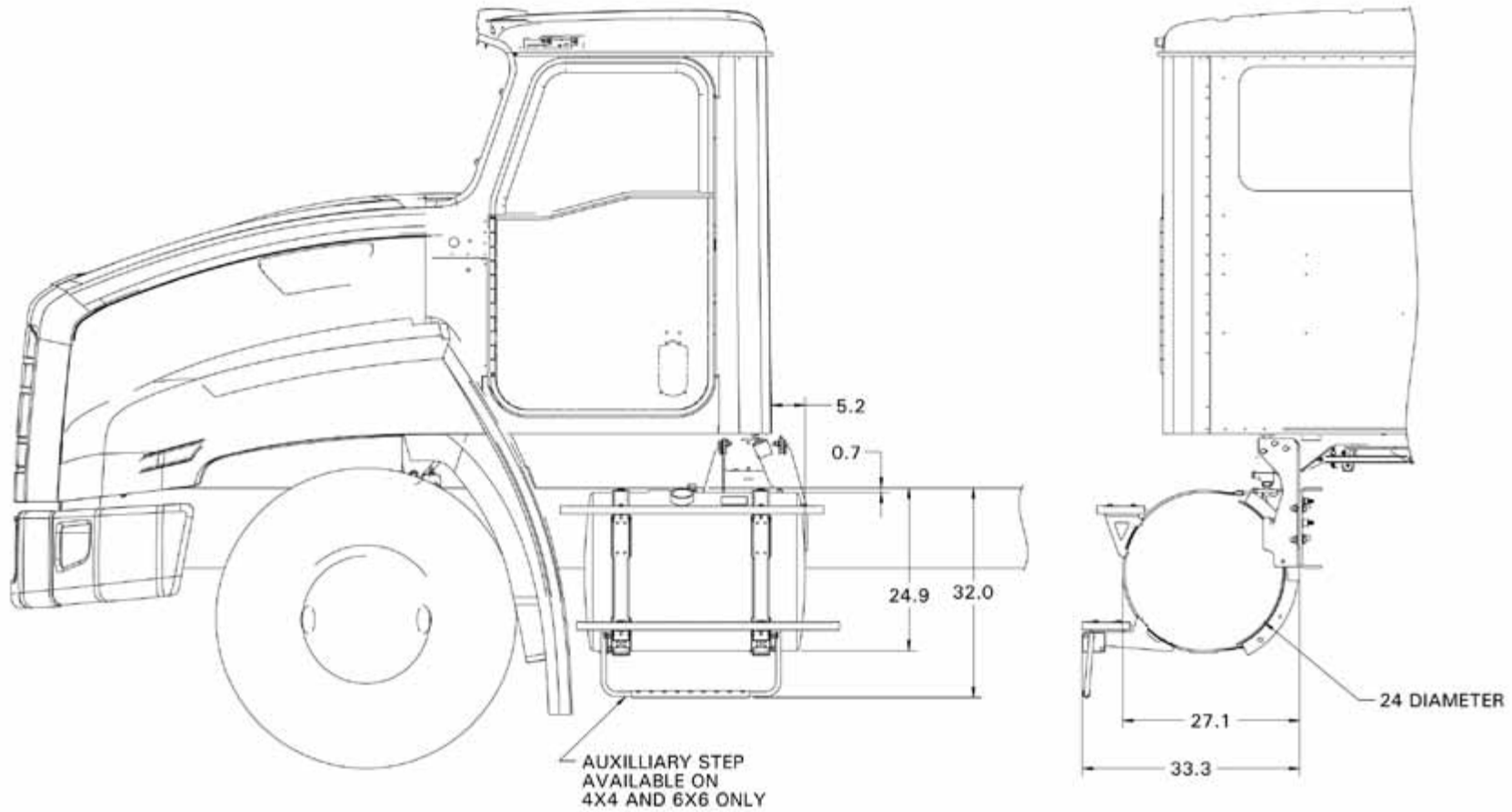

FUEL TANKS

FUEL TANK LOCATION — 80 GALLON (EGR ONLY)

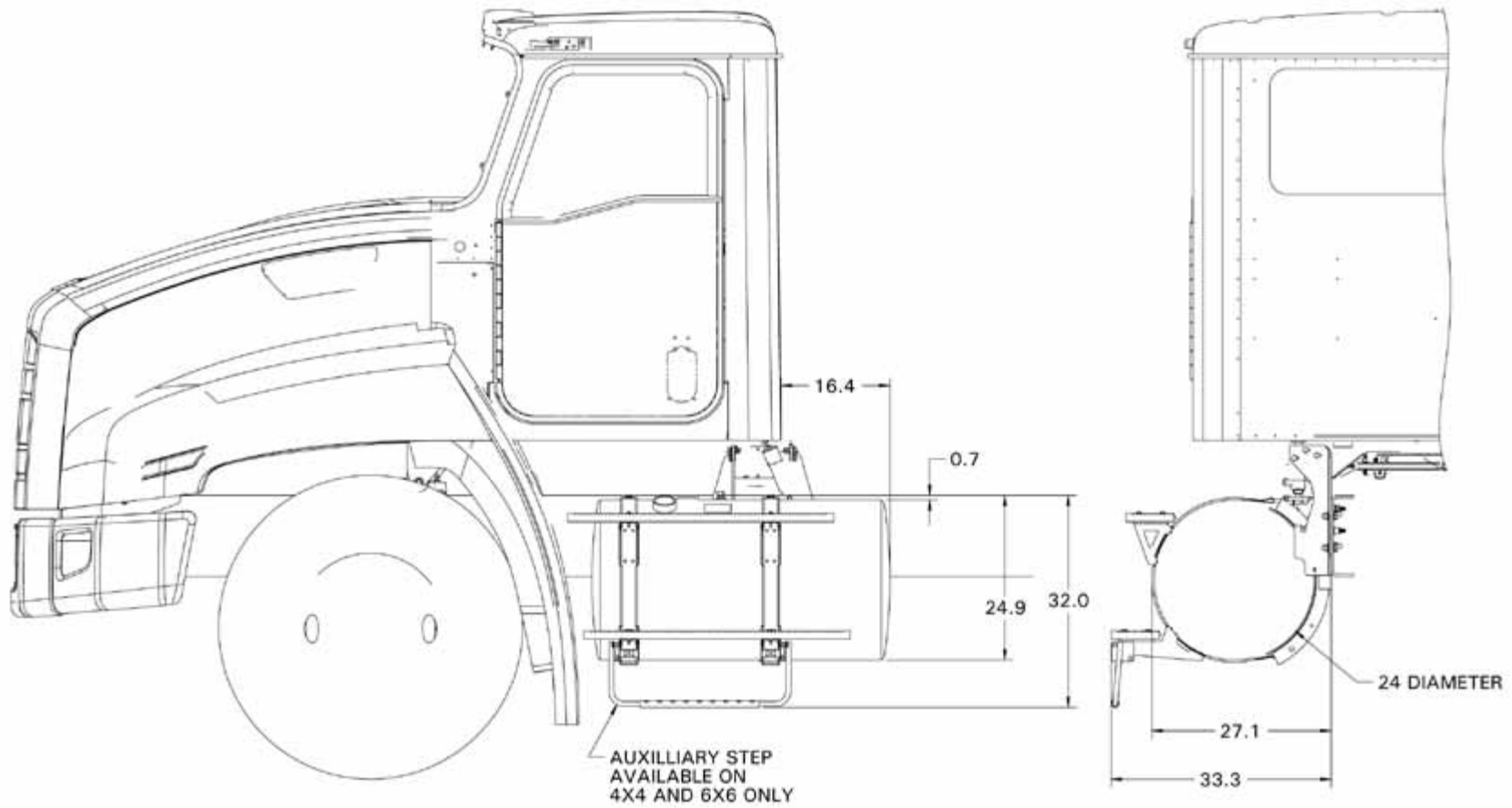

FUEL TANKS

FUEL TANK LOCATION — 100 GALLON (EGR ONLY)

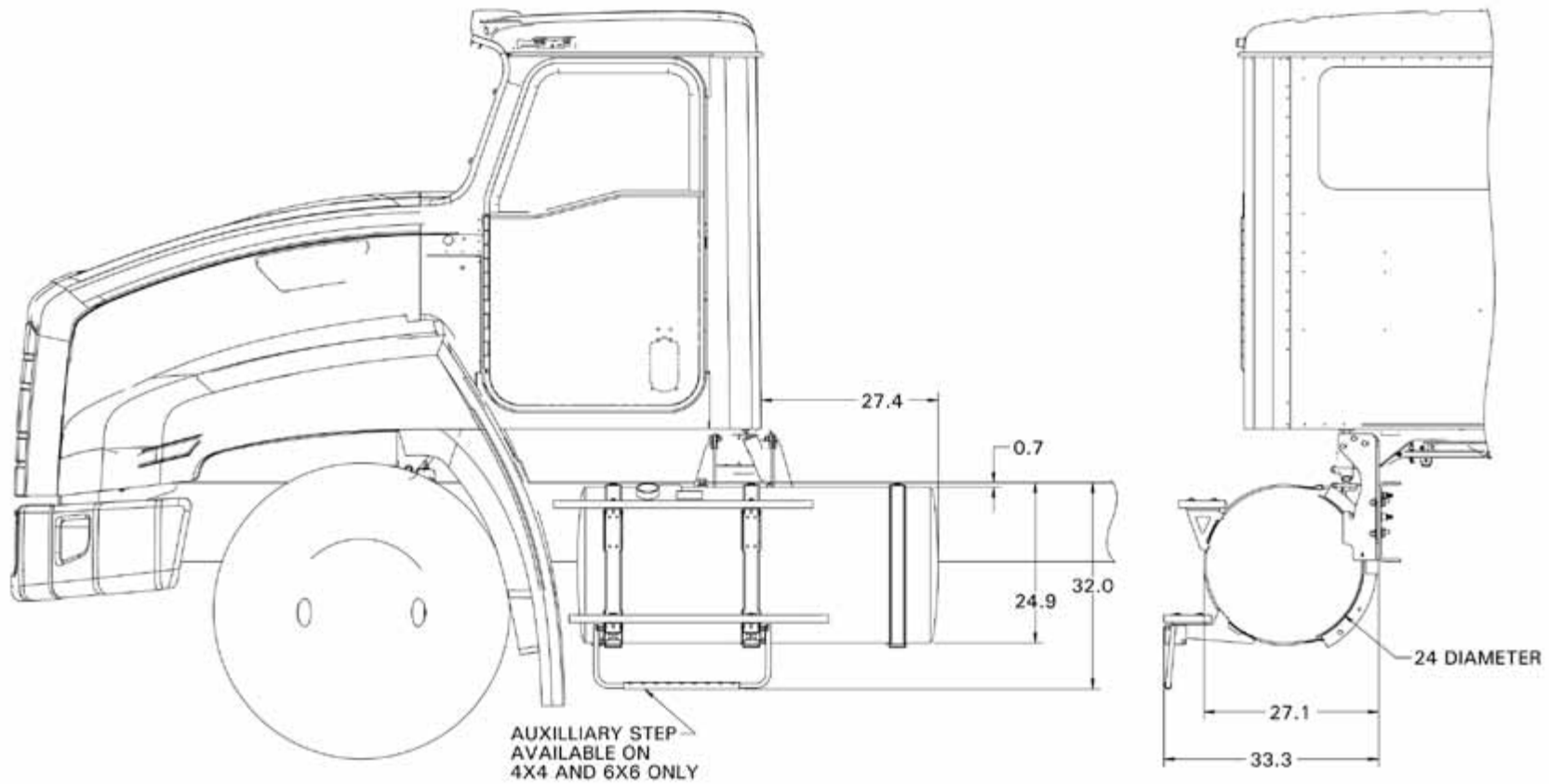

FUEL TANKS

FUEL TANK LOCATION — 120 GALLON (EGR ONLY)

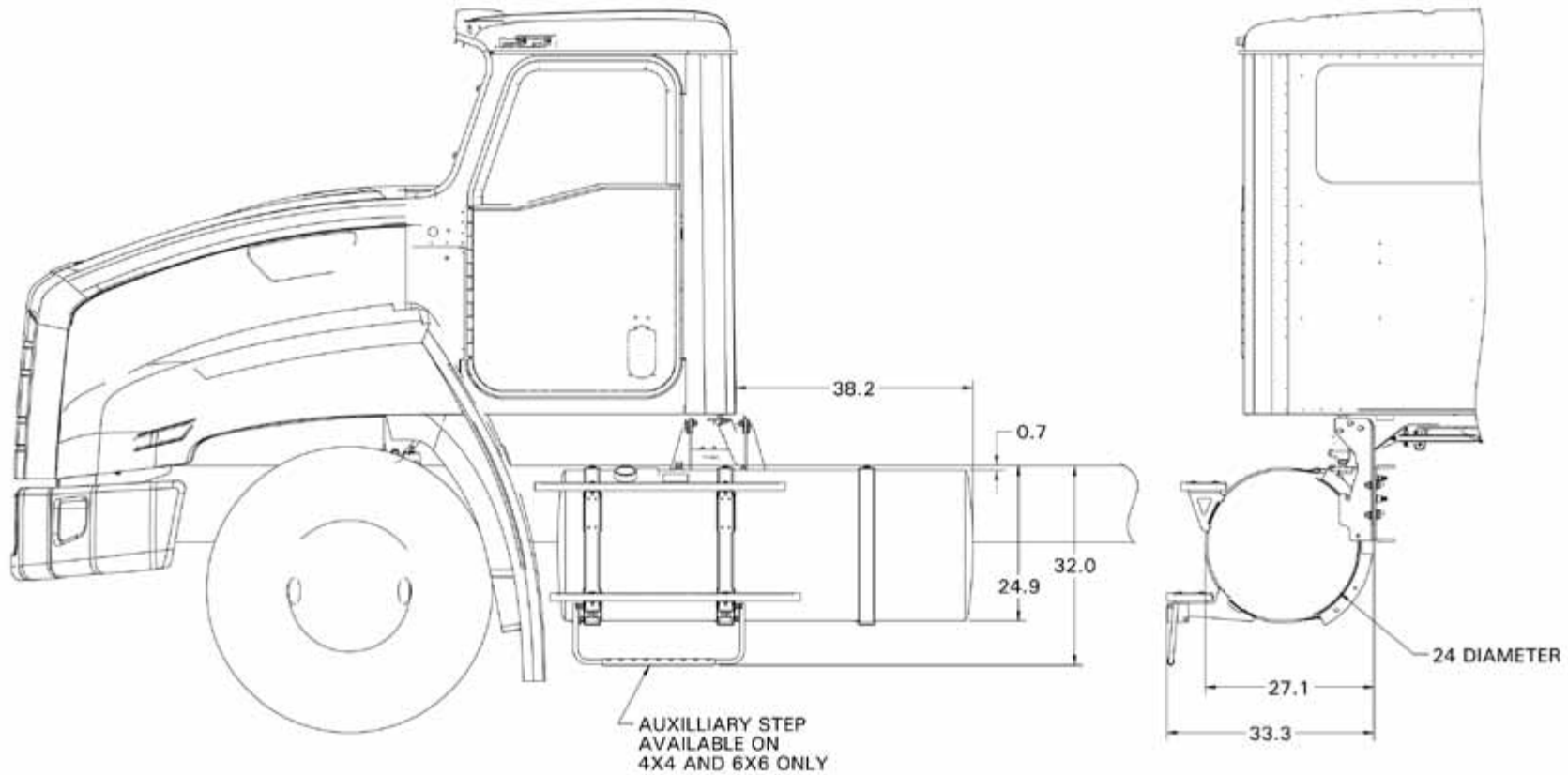

FUEL TANKS

24" DIAMETER FUEL TANK BACK OF CAB LOCATIONS 80, 100, 120 GALLON LONG HOOD (SCR ONLY)

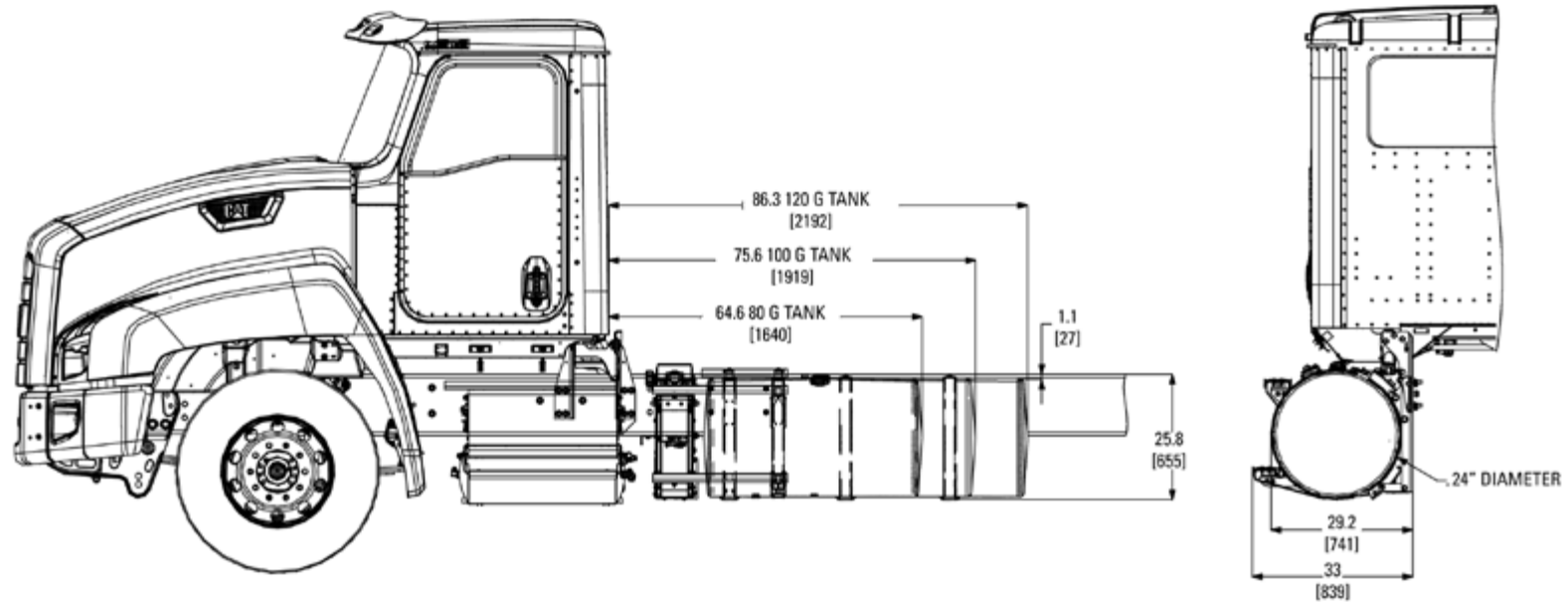

FUEL TANKS

24" DIAMETER FUEL TANK LOCATIONS 80, 100, 120 GALLON SHORT HOOD (SCR ONLY)

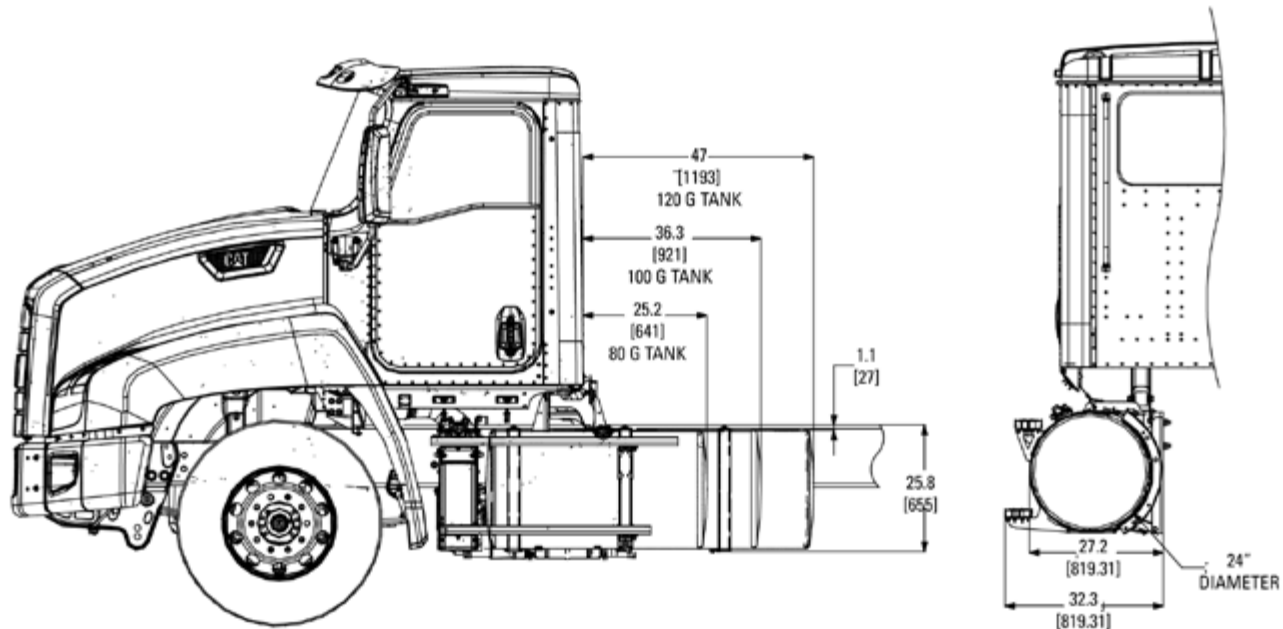

FUEL TANKS

26" DIAMETER FUEL TANK LOCATIONS 70, 80, 100, 120 GALLON LONG HOOD — SCR

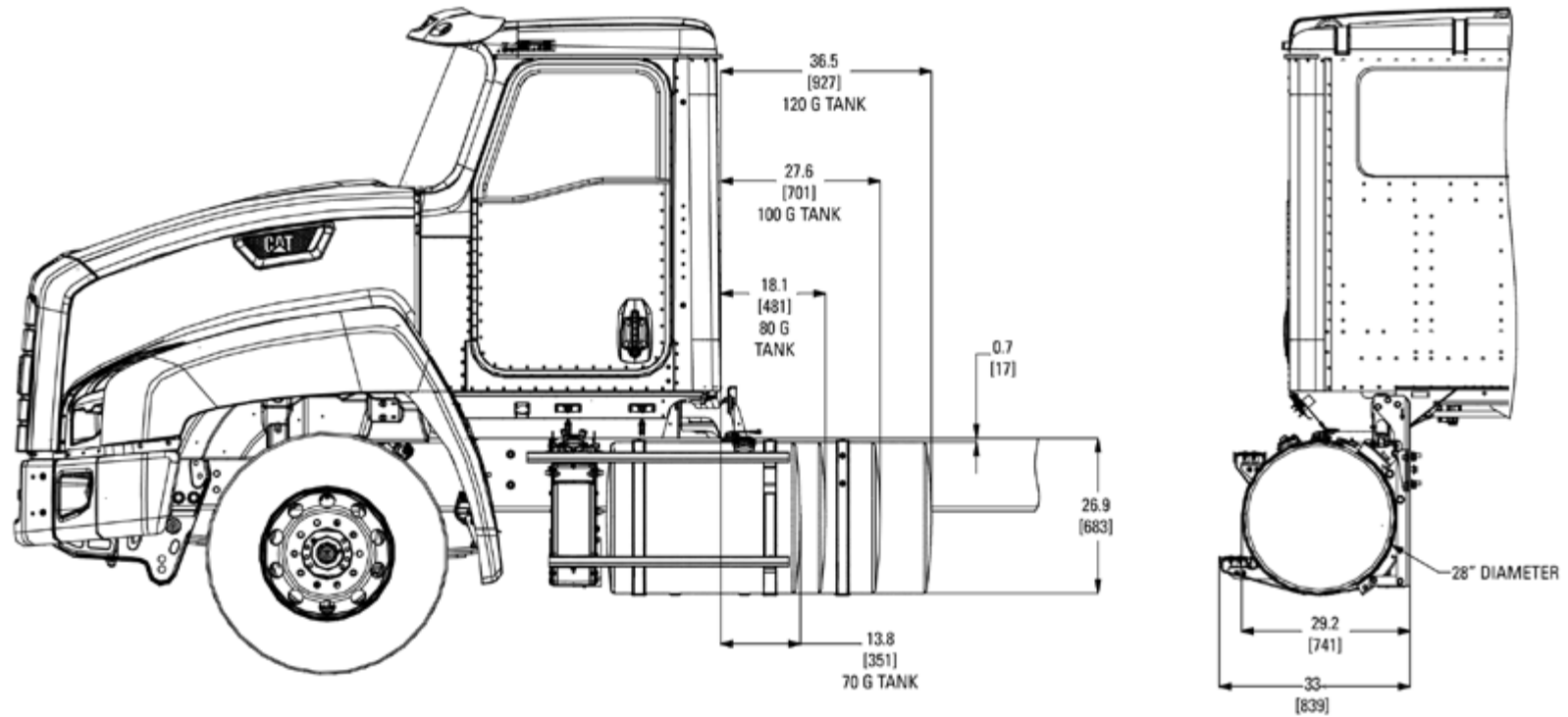

CAB

AIR CONDITIONING SYSTEM MODIFICATIONS

The HVAC system provided with Cat® Series should not be modified. NO additional components should be added to the factory installed HVAC system as it is delivered from the manufacturer. If additional air conditioning capacity is needed, a completely independent system should be added to handle the additional load requirements of the Body Builder. There are additional costs for a second system; it would however, provide for optimal performance from both HVAC systems.

The factory installed system cannot be modified in any manner. Modification of the HVAC system will void the Caterpillar Warranty on that system. There are several reasons why HVAC system modifications are not permitted.

- » The factory installed HVAC system is optimized for the evaporator, condenser and compressor combination on the vehicle. To introduce an additional evaporator (or other components) into the system will create an imbalance and unsatisfactory performance.
- » The factory compressor clutch is cycled by the RCD software residing in the A/C control head. Modification of this control system to add an auxiliary system could result in damage to other vehicle components.
- » Since the HVAC system has been optimized for the factory components, there is no extra condenser capacity available for an auxiliary evaporator.

CAB

CAB DIMENSIONS

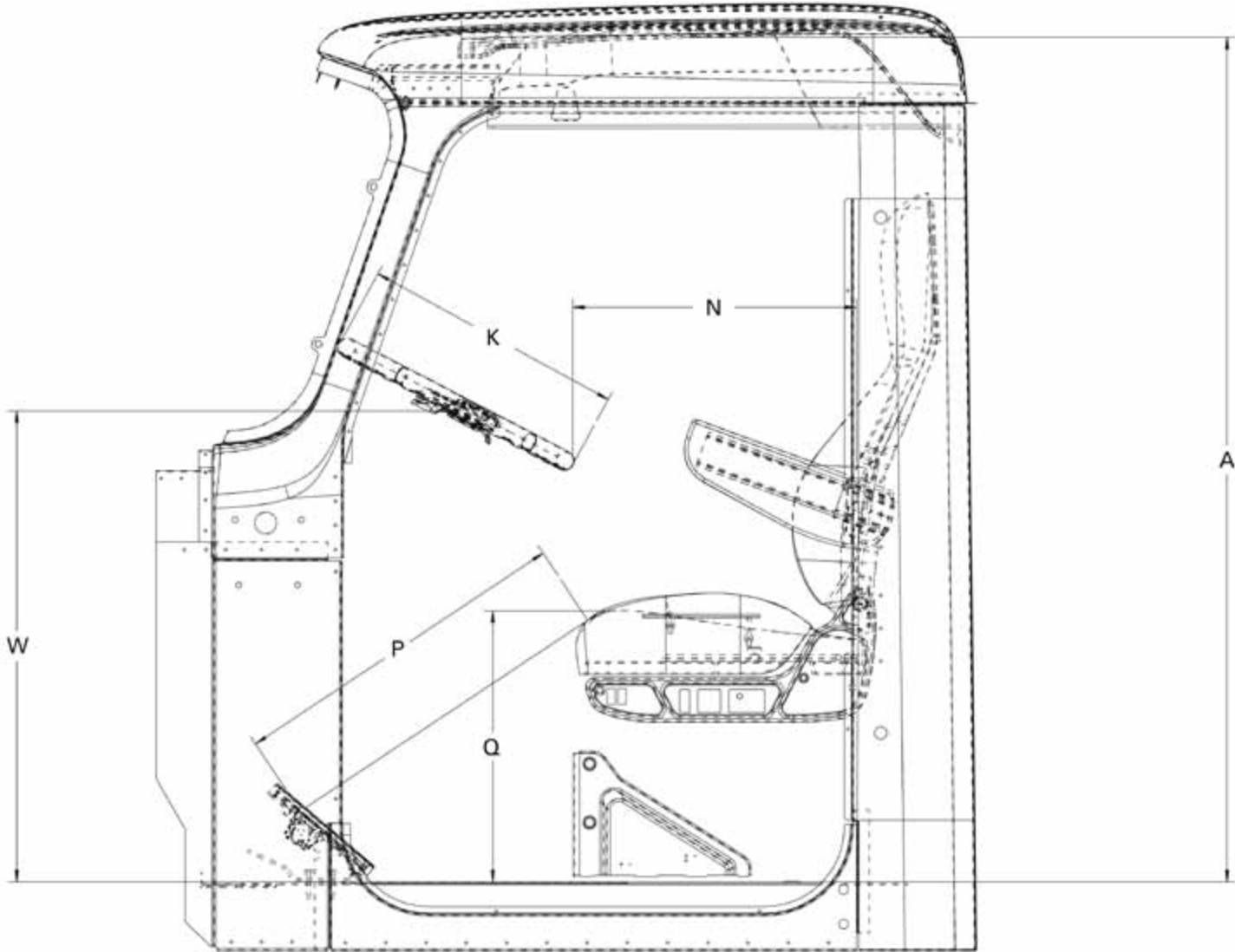

CAB

CAB DIMENSIONS

| KEY | DESCRIPTION | DIMENSION (INCHES) |
|-----|----------------------------------|-----------------------------------|
| A | Cab Height | 64.77 |
| B | Windshield Angle | 22° at Center, 19° at A-Pillar |
| C | Inside - Cowl to Back of Cab | 52.00 |
| E | Interior Width | 70.00 |
| F | Door Thickness | 3.00 |
| G | Outside Cab Width | 76.00 |
| K | Steering Wheel Diameter | 18.00 |
| L | Floor to Top of Door Opening | 52.50 |
| M | Floor to Headliner | 57.75 |
| N | Steering Wheel Rim to Seat Back | 19.38 |
| P | Pedal to Seat | 23.58 |
| Q | Floor to Seat | 18.55 |
| R | Floor to Bottom of Cab | 4.60 |
| S | Cowl to Door Opening | 8.50 |
| T | Door Opening Width | 35.00 |
| U | Door Opening to Back of Cab | 8.50 |
| V | Bottom of Cab to Bottom of Frame | 20.90 |
| W | Floor to Steering Wheel Center | 32.20 |

CAB

DOOR SWING CLEARANCE

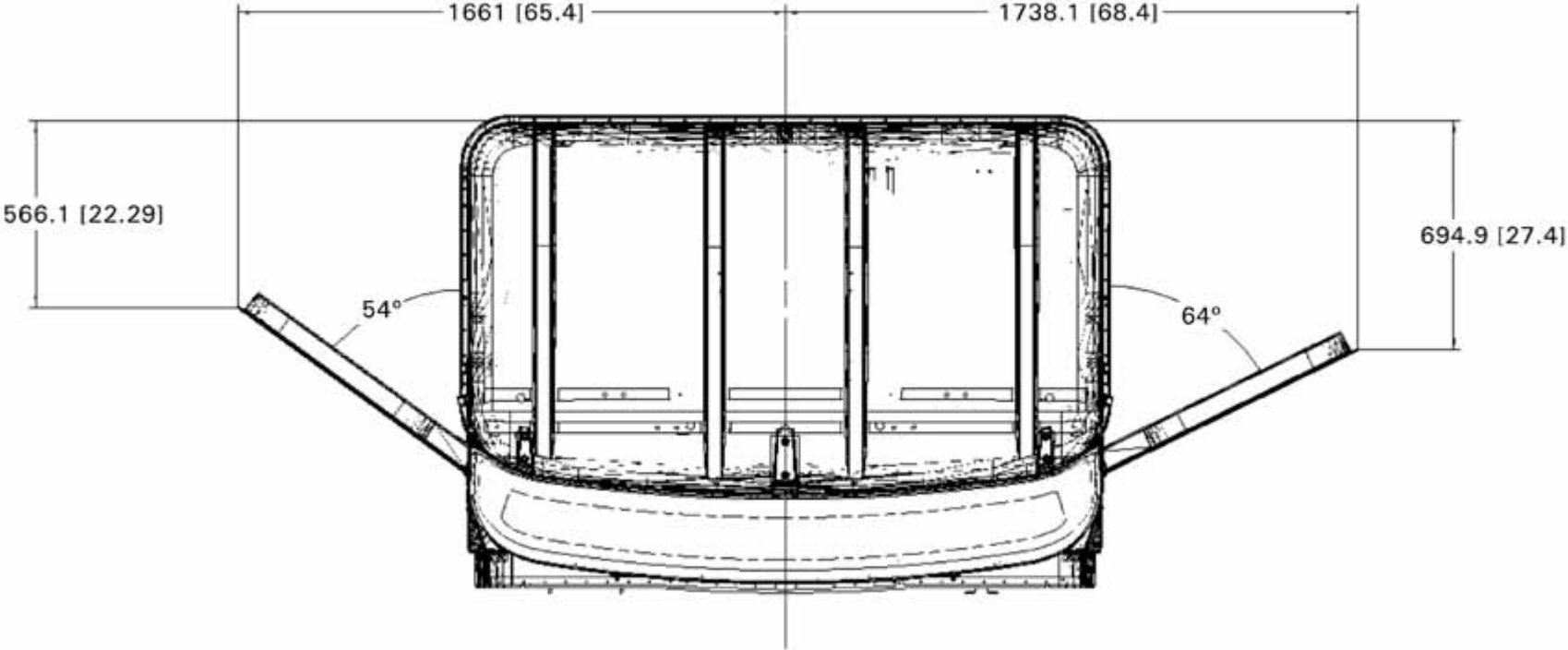

CAB

REAR CAB SUSPENSION

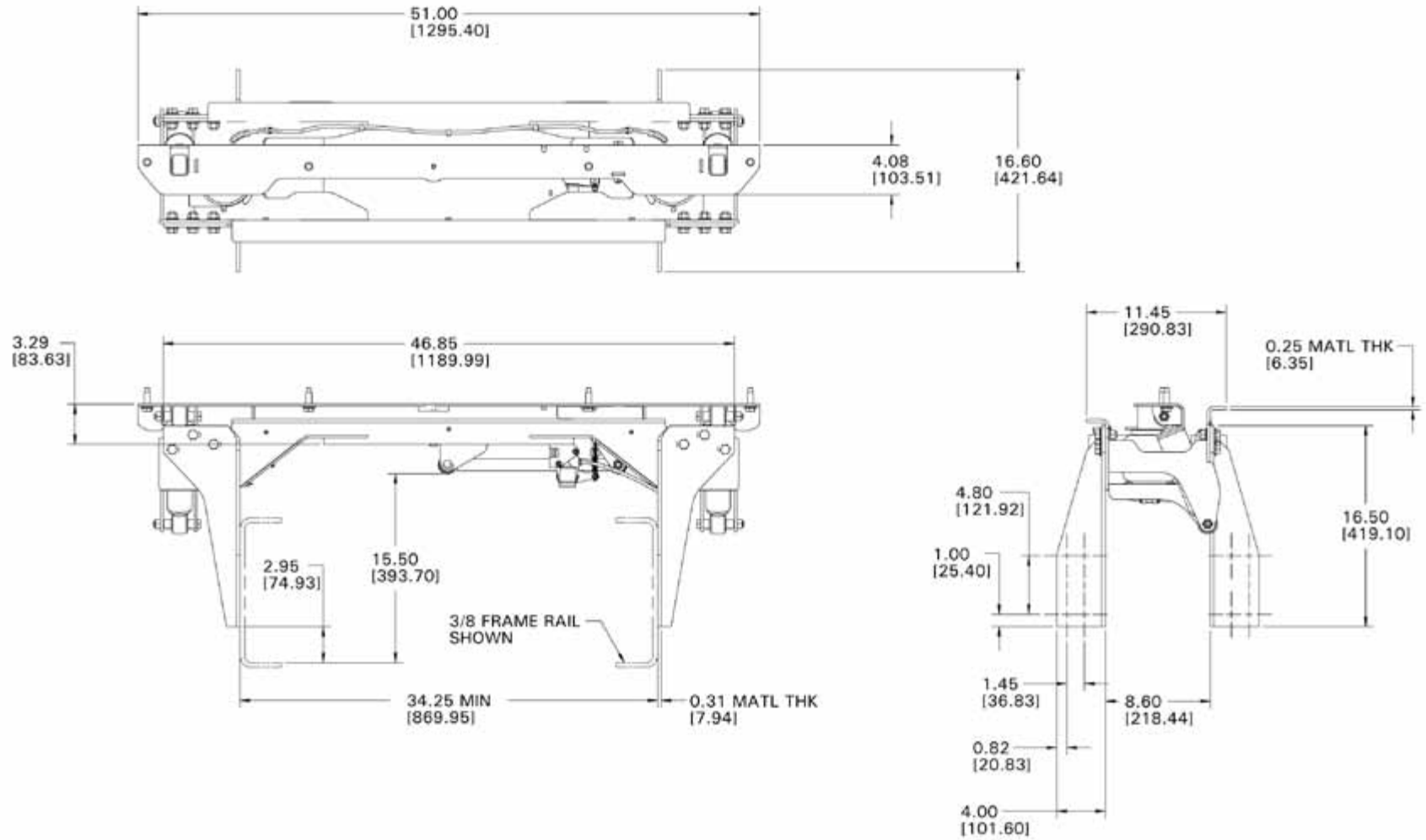

CAB

PTO AIR SWITCH

Trucks equipped with a PTO switch under Instrument Cluster.

The PTO switch mounted on the bottom of the dash and under the Instrument Cluster is an AIR switch that can switch chassis system air. The air line is routed from inside the cab through the firewall. The air line is included in the bundle of air lines that are routed from the cab and is routed under the cab. This air line is NOT capped or plugged.

Using this Switch to interact with the CX transmission PTO feature requires an air actuated pressure switch to provide the required contact closure.

CAB

USER SWITCHES

Trucks equipped with the Optional Center Dash mounted switches, labeled User 1-6, are electrical circuitswitches. A separate 20 amp fuse is provided for each switch. These switches are in a package of two, four or six. The wires from these switches (2 or 6) are terminated in a 6-pin connector. This connector is part of the wiring harness and it located behind the center dash. Remove the passenger side fuse panel cover to access this connector. Note: These circuits are not designed for inductive loads.

Wiring Diagram of the Optional Switches

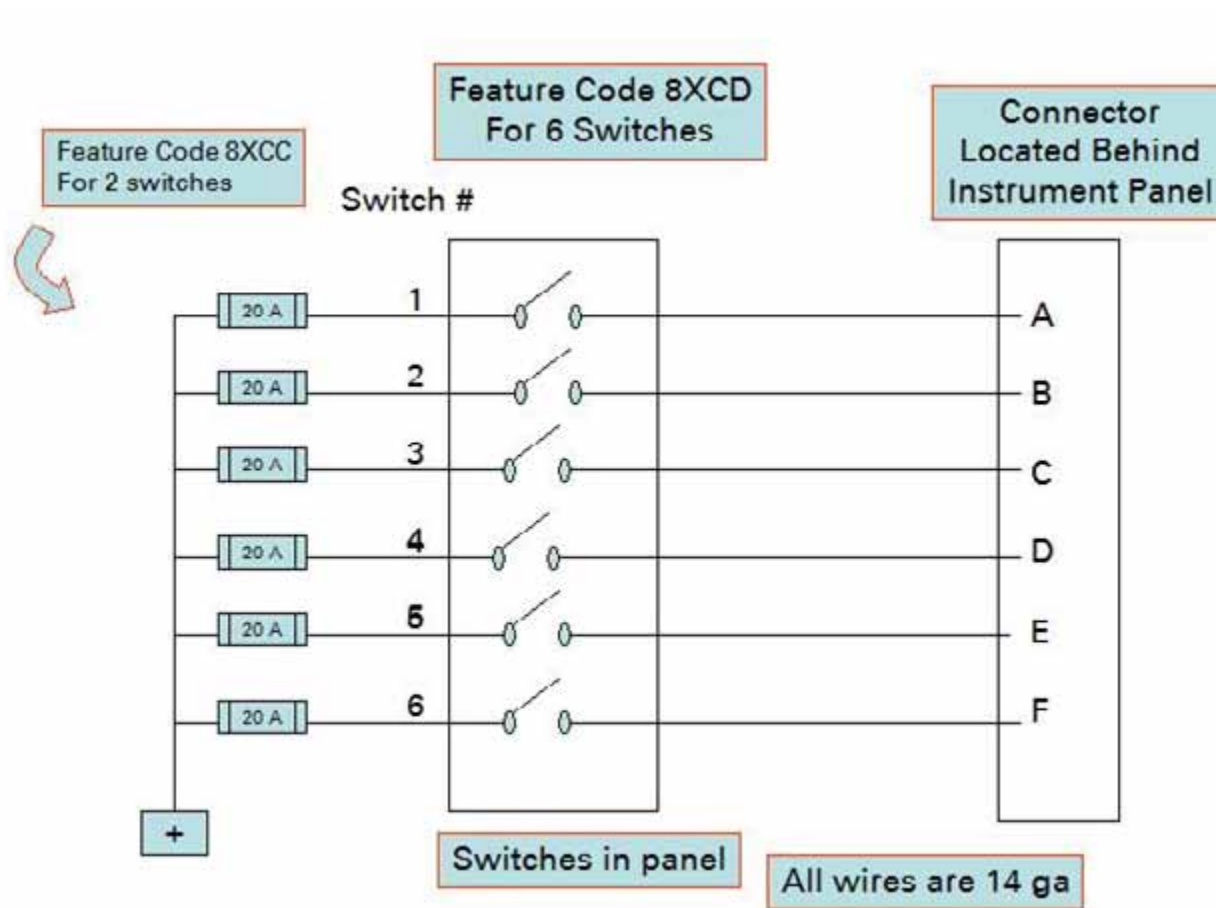

CAB

OPTIONAL AUXILIARY SWITCH LOCATION

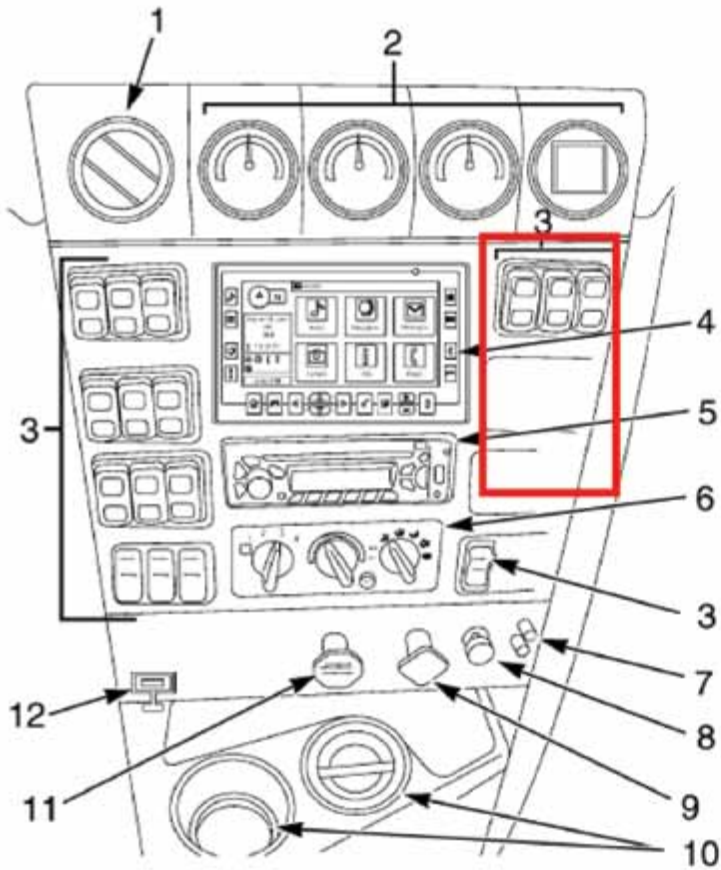

1. Vent
2. Auxiliary Gauge Pack (Optional)
3. Switches
4. Storage Compartment or Driver Information Display (Optional)
5. Radio/Stereo
6. Climate Control
7. Two Post Power Socket
8. Cigarette Lighter
9. Parking Brake
10. Cup Holder/Ashtray
11. Trailer Air Supply Valve

Optional Auxiliary Switches will be located in this area

GOVERNMENT REQUIREMENTS

YOUR OBLIGATIONS UNDER THE LAW

The important information in this section will acquaint you with U.S. and Canadian safety and emission standards that apply to Cat® Vocational vehicles sold in the two countries, of those laws that established these standards, and the identity of the parties responsible for certification of compliance for both **Complete Vehicles** and **Incomplete Vehicles**. To the best of Caterpillar® Inc. knowledge, it is correct as of the date of this printing. Caterpillar Inc., however cannot accept responsibility for it's completeness and currency. User must ascertain this on his own.

The National Traffic and Motor Vehicle Safety Act of 1966, in the U.S., gave rise to the Federal Motor Vehicle Safety Standards (FMVSS). In addition, The Environmental Protection Agency, through the Environmental Policy Act of 1969, set forth environmental protection standards. In Canada, the Motor Vehicle Safety Act of 1970 established the Canadian Motor Vehicle Safety Standards (CMVSS) Act.

These standards place the responsibility for compliance of a **Complete Vehicle** on the vehicle and engine manufacturers. Any Cat Vocational vehicle purchased from Caterpillar Inc., as a **Complete Vehicle** as defined by section 567.3 of Title 49 of the Code of Federal Regulations (CFR) is certified by Navistar to comply with all applicable safety standards provided modifications or additions to the vehicle do not result in non-compliance with applicable U.S. and Canadian standards to which Navistar has certified compliance. Also, it is the responsibility of every Cat Dealer to assure that the service work or modifications that can affect compliance, performed on a new vehicle prior to delivery to the customer, meets the requirements specified by all mandated standards.

It is the responsibility of the Final-Stage Manufacturer who typically installs a body, a fifth wheel, or any other equipment, or makes any modifications to an **Incomplete Vehicle** supplied by Caterpillar Inc. to certify compliance with the applicable standards for the vehicle when completed. Further, it is the responsibility of the Final-Stage Manufacturer to determine, and fully comply with, any additional requirements of the several States and Provinces. In addition, the Final-Stage Manufacturer must certify compliance with any other standards set forth in U.S. and Canadian regulations, statutes and ordinances.

Penalties For Violations

Violation of the provisions contained within the U.S. Federal Motor Vehicle Safety Standards is subject to fines of up to \$6,000 per vehicle or up to a maximum of \$17,350. The following violations are subject to these penalties:

- 1) Any manufacturer who knowingly or unknowingly produces for sale a motor vehicle subject to the law, but which does not meet all the applicable provisions of the law.
- 2) Any party who sells or offers for sale a motor vehicle built after the effective date of a standard, which in the knowledge of the selling party does not comply with the standard.
- 3) Any party (manufacturer, dealer, body builder or other) who completes a vehicle for sale in compliance with the law but fails to certify the completed vehicle in the prescribed manner.
- 4) Any party who knowingly certifies a vehicle as complying, which does not in fact meet the requirements of the law.

GOVERNMENT REQUIREMENTS

YOUR OBLIGATIONS UNDER THE LAW

Situations where the government was intentionally misled in regards to safety related defects are criminal violations and are punishable by a maximum of 15 years in prison.

The U.S. Department of Transportation has declared its intent to institute procedures periodically to inspect vehicles subject to the law, and to implement enforcement procedures that will permit detection of violations.

The requirements of the law are stringent and the penalties for violation are severe. It is therefore mandatory that all personnel involved in any of the following aspects of motor vehicles become familiar with the provisions of the law as they relate to their responsibilities.

- » **Installation of equipment sub-assemblies and/or bodies (Intermediate and Final Stage Manufacturer)**
- » **Sales**
- » **Preparation for delivery**
- » **Modification or conversion (Alterer)**
- » **Maintenance and repair**

Violation of the Canada Motor Vehicle Safety Standards law carries similar penalties.

NOTE: The Canadian, Mexican, and U.S. vehicle standards, which regulate the manufacture of vehicles for sale in their respective countries, may at any time exceed all or a portion of the mandated requirements of one or both of the other two countries. This situation exists due to established standards or regulatory revisions in one country, which have not yet been incorporated by the other(v).

Each of these countries require that any vehicle crossing its border(s) in commerce must comply with all applicable standards of their country and comply with the standards that were in effect as of the date of manufacture of that vehicle.

GOVERNMENT REQUIREMENTS

FEDERAL MOTOR VEHICLE STANDARDS (FMVSS) AND CANADIAN MOTOR VEHICLE SAFETY STANDARDS (CMVSS)

The following standards of Title 49 of the CFR apply to all liquid fueled vehicles having a GVWR greater than 10,000 pounds. Presently, all Cat[®] trucks and buses are powered with diesel engines and have been designed to have a GVWR of greater than 10,000 pounds. For any Caterpillar Vocational Truck purchased from Caterpillar Inc. and defined by section 567.3 of Title 49 of the CFR as an Incomplete Vehicle, consult the Incomplete Vehicle Document (IVD) provided with each Incomplete Vehicle to determine those particular safety standards with which the vehicle complies. Any standards, with which Navistar cannot certify compliance because of the level of completion of that vehicle, become the responsibility of the Intermediate Manufacturer or Final-Stage Manufacturer or both.

GOVERNMENT REQUIREMENTS

FEDERAL MOTOR VEHICLE STANDARDS (FMVSS) AND CANADIAN MOTOR VEHICLE SAFETY STANDARDS (CMVSS)

| SAFETY STANDARD IDENTIFICATION (APPLICABLE TO ALL COMPLETED VEHICLES GREATER THAN 10,000 LBS.) |
|--|
| FMVSS 101, CMVSS 101 - Controls, Telltales, and Indicators |
| FMVSS 102, CMVSS 102 - Transmission Shift Position Sequence, Starter Interlock and Transmission Braking Effect |
| FMVSS 103, CMVSS 103 - Windshield Defrosting and Defogging Systems |
| FMVSS 104, CMVSS 104 - Windshield Wiping and Washing Systems |
| FMVSS 105, CMVSS 105 - Hydraulic and Electric Brake Systems |
| FMVSS 106, CMVSS 106 - Brake Hoses |
| FMVSS 108, CMVSS 108 - Lamps, Reflective Devices and Associated Equipment |
| FMVSS 111, CMVSS 111 - Rearview Mirrors |
| FMVSS 113, CMVSS 113 - Hood Latch System |
| U.S. 49 CFR part 565, CMVSS 115 - Vehicle Identification Number Requirements |
| FMVSS 116, CMVSS 116 - Motor Vehicle Brake Fluids |
| FMVSS 119, CMVSS 119 - New Pneumatic Tires for Vehicles other than passenger cars |
| FMVSS 120, CMVSS 120 - Tire selection and Rims for vehicles with a GVWR of more than 4,536 Kilograms (10,000 pounds) |
| FMVSS 121, CMVSS 121 - Air Brake Systems |
| FMVSS 124, CMVSS 124 - Acceleration Control Systems |
| FMVSS 125, CMVSS 125 - Warning Devices |
| FMVSS 205, CMVSS 205 - Glazing Materials |
| FMVSS 206, CMVSS 206 - Door Locks and Door Retention Components |
| FMVSS 207, CMVSS 207 - Seating Systems |
| FMVSS 208, CMVSS 208 - Occupant Crash Protection |
| FMVSS 209, CMVSS 209 - Seat Belt Assemblies |
| FMVSS 210, CMVSS 210 - Seat Belt Assembly Anchorages |
| FMVSS 213, CMVSS 213 - Child Restraint Systems |
| FMVSS 225, CMVSS 225 - Child Restraint Anchorage System |
| FMVSS 302, CMVSS 302 - Flammability of Interior Materials |
| FMVSS 403 - Platform Lift Systems for Motor Vehicles |
| FMVSS 404 - Platform Lift Installations in Motor Vehicles |

Table ii.1

GOVERNMENT REQUIREMENTS

ADDITIONAL LIGHTING INFORMATION

Lighting Devices and Reflectors Required by FMVSS 108 and CMVSS 108

| REQUIRED VEHICLE LIGHTING EQUIPMENT FOR TRUCKS AND BUSES WITH AN OVERALL WIDTH OF 80 INCHES OR MORE | | | | | |
|---|------------|-------|-----------------|---|---|
| REQUIRED LIGHTING EQUIPMENT | QUANTITY | COLOR | LOCATION | POSITION | HEIGHT ABOVE ROAD SURFACE (IN INCHES MEASURED FROM THE CENTER OF THE LAMP ON VEHICLE AT CURB HEIGHT) |
| Headlamps | 2 at least | White | Front | On the front at the same height, an equal number at each side of the vertical centerline as far apart as practicable. | Not less than 22 or more than 54. |
| Turn Signal (Front) | 2 | Amber | At or nearfront | One on each side of the vertical centerline at the same height and as far apart as practicable. | Not less than 15 or more than 83. |
| Identification Lamp (Front) | 3 | Amber | Front | As close as practicable to the vertical centerline of the vehicle or the vertical centerline of the cab where different from the centerline of the vehicle. | All three on the same level as close as practicable to the top of the vehicle with lamp centers spaced not less than 6" or more than 12" apart. |
| Tail Lamp | 2 | Red | Rear | One lamp each side of the vertical centerline at the same height and as far apart as practicable | Both on the same level between 15 and 72. |

Table ii.2

GOVERNMENT REQUIREMENTS

ADDITIONAL LIGHTING INFORMATION

| REQUIRED VEHICLE LIGHTING EQUIPMENT FOR TRUCKS AND BUSES WITH AN OVERALL WIDTH OF 80 INCHES OR MORE (CONTINUED) | | | | | |
|---|----------|-------|-------------------------------|--|--|
| REQUIRED LIGHTING EQUIPMENT | QUANTITY | COLOR | LOCATION | POSITION | HEIGHT ABOVE ROAD SURFACE (IN INCHES MEASURED FROM THE CENTER OF THE LAMP ON VEHICLE AT CURB HEIGHT) |
| Stop Lamp | 2 | Red | Rear | One lamp each side of the vertical centerline at the same height and as far apart as practicable | Both at the same level between 15 and 72. |
| Front Clearance Lamps | 2 | Amber | One on each side of the front | One on each side of the vertical centerline to indicate width. | Both at the same level as high as practicable. |
| Rear Clearance Lamps | 2 | Red | One on each side of the rear | One on each side of the vertical centerline to indicate overall width. | Both at the same level as high as practicable. |
| Side Marker Lamp, Intermediate | 2 | Amber | One on each side | At or near midpoint between front and rear side markers lamps, if vehicle over 30' in length. | Not less than 15. |
| Reflex Reflector Intermediate (Side) | 2 | Amber | One on each side | At or near midpoint between front and rear side reflectors if over 30' in length. | Between 15 and 60. |
| Reflex Reflector (Rear) | 2 | Red | Rear | One on each side of the vertical centerline, as far apart as practicable | Both on the same level, between 15 and 60. |
| Reflex Reflector (Rear Side) | 2 | Red | One on each side (rear) | As far to the rear as practicable. | Between 15 and 60. |
| Reflex Reflector (Front Side) | 2 | Amber | One on each side (front) | As far to the front as practicable. | Between 15 and 60. |

Table ii.2

GOVERNMENT REQUIREMENTS

ADDITIONAL LIGHTING INFORMATION

| REQUIRED VEHICLE LIGHTING EQUIPMENT FOR TRUCKS AND BUSES WITH AN OVERALL WIDTH OF 80 INCHES OR MORE (CONTINUED) | | | | | |
|---|----------|--------------|-----------------------|---|---|
| REQUIRED LIGHTING EQUIPMENT | QUANTITY | COLOR | LOCATION | POSITION | HEIGHT ABOVE ROAD SURFACE (IN INCHES MEASURED FROM THE CENTER OF THE LAMP ON VEHICLE AT CURB HEIGHT) |
| License Plate Lamp Rear | 1 | White | At rear license plate | To illuminate the license plate from the top or sides | No requirements. |
| Side Marker Lamp (Front) | 2 | Amber | One on each side | As far to the front as practicable. | Not less than 15. |
| Side Marker Lamp (Rear) | 2 | Red | One on each side | As far to the rear as practicable. | Not less than 15. |
| Turn Signal (Rear) | 2 | Amber or Red | Rear | One lamp each side of the vertical centerline as far apart as practicable | Both on the same level between 15 and 83. |
| Identification Lamp (Rear) | 3 | Red | Rear | One as close as practicable to vertical centerline, one on each side. | All three on the same level as close as practicable to the top of the vehicle with lamp centers spaced not less than 6" or more than 12" apart. |
| Vehicular Hazard Warning Flashing Lamps | 2 | Amber | Front | One lamp each side of the vertical centerline as far apart as practicable | Both on the same level between 15 and 83. |
| | 2 | Amber or Red | Rear | | |
| Backup Lamp | 1 | White | Rear | Rear | No requirements. |

Table ii.2

GOVERNMENT REQUIREMENTS

ADDITIONAL REQUIREMENTS

Additional Requirements: EPA

EPA Part 205 Subpart B, CMVSS 1106 – Noise Emission For Medium And Heavy Trucks

Incomplete Vehicles identified as a **Chassis Cab** by Navistar or Caterpillar Inc., and all **Complete Vehicles** will comply with the requirements specified by EPA PART 205 SUBPART B and CMVSS 1106 provided that no changes are made to the factory installed noise generating and/or suppression equipment installed by International.

EPA Part 86, CMVSS 1100 – Emission Control

Engines provided with Cat Vocational trucks will comply with all applicable exhaust emission standards. Modifications to the vehicle and/or engine, which will cause noncompliance, are prohibited by the regulations. For further information see the vehicle owner's manual and the engine manual.

Replacement Or Service Parts

The Motor Vehicle Safety Standards primarily specify the requirements and/or performance standards that a Complete Vehicle must comply with. However, certain specific components of the vehicle, when sold by a dealer or distributor as replacement or service parts, are required to comply with the requirements and/or performance standards specified by the standards. Certification of compliance must also be provided for these components and those items that are subject to these procedures are as follows:

- » **Windshield and window glass – FMVSS/CMVSS 205**
- » **Seat belts – FMVSS/CMVSS 209**
- » **Hydraulic brake hose – FMVSS/CMVSS 106**
- » **Hydraulic brake fluids – FMVSS/CMVSS 116**
- » **Lamps and reflective devices – FMVSS/CMVSS 108**
- » **Warning devices – FMVSS 125 (Reflective Triangle)**
- » **Tires and Wheels – FMVSS/CMVSS 119/120**
- » **Platform Lift System – FMVSS 403**

The standards require that all of the above items manufactured for sale, whether for use in the manufacture of a vehicle or for sale as parts, must comply with applicable provisions of the safety standards. Such items when sold by dealers or distributors must be labeled to certify compliance. Such labeling may be placed on the part itself or on the container in which the part is shipped. The items listed above that are manufactured by or for Caterpillar Inc. as service parts will comply with all applicable standards as required.

GOVERNMENT REQUIREMENTS

ADDITIONAL REQUIREMENTS

Certification of Incomplete Vehicles Sold by Caterpillar® Inc.

In accordance with the laws of the United States and Canada all vehicles manufactured for sale and sold for use in these countries must comply with the applicable federal safety standards and certification of compliance must be provided with the vehicle.

Section 567.3 of Title 49 of the CFR defines an Incomplete Vehicle as an assemblage consisting, at a minimum, of chassis (including the frame) structure, power train, steering system, suspension system, and braking system, in the state that those systems are to be part of the completed vehicle, but requires further manufacturing operations, to become a completed vehicle. For an Incomplete Vehicle sold by Caterpillar Inc. to be classified as a Complete Vehicle, subsequent manufactures must mount a body or other load carrying equipment on the chassis prior to delivery to the end user so that it can perform its intended function.

Incomplete Vehicle Manufacturer

Definition

Section 567.3 of Title 49 of the CFR defines an Incomplete Vehicle Manufacturer as a person who manufactures an incomplete vehicle by assembling components none of which, taken separately, constitute an incomplete vehicle.

Compliance Responsibility

As sold by Caterpillar Inc., an Incomplete Vehicle is built with all appropriate safety items that comply with the applicable regulatory requirements to the extent that the vehicle's state of completion will permit. To obtain a Complete Vehicle status under section 567.3 of Title 49 of the CFR, an Intermediate or Final-Stage Manufacturer must mount a body or other similar load carrying equipment on the chassis prior to delivery to the end user.

An **Incomplete Vehicle** sold by Caterpillar will be identified with one of the following designations depending on the vehicle's state of completion:

- » **Chassis Cab**
- » **Flat Back Cowl (FBC) Chassis Bus or School Bus**
- » **Partial Cab Bus or School Bus**
- » **Partial Cab Truck**
- » **Stripped Chassis**

GOVERNMENT REQUIREMENTS

ADDITIONAL REQUIREMENTS

In accordance with section 568.4 of Title 49 of the CFR, Navistar furnishes an **Incomplete Vehicle** Document (IVD) with each **Incomplete Vehicle**. This document provides the following information:

- » **Name and mailing address of the Incomplete Vehicle manufacturer**
- » **Date of manufacture**
- » **Vehicle Identification Number**
- » **GAWR (Gross Axle Weight Rating) for each axle of the intended Complete Vehicle**
- » **GVWR (Gross Vehicle Weight Rating) of the intended Complete Vehicle**
- » **Vehicle Type into which the Incomplete Vehicle may appropriately be manufactured**
- » **Suitable tire and rim choice with inflation pressure**
- » **List of all Federal U.S. or Canadian safety standards applicable to the type of vehicle. (Those standards to which the vehicle complies as produced by Navistar, Inc. will be identified.)**

For all Incomplete Vehicles except those without a cab, the IVD is placed in the left hand door dispatch compartment. For Incomplete Vehicles without a cab, the IVD is placed in a clear plastic envelope and strap locked to the radiator stay rod. In accordance with section 567.5 of Title 49 of the CFR, an Incomplete Vehicle Information Label will be affixed to the hinge pillar, door latch post, or door edge that meets the door latch post, next to the driver's seating position (reference Figure-ii.5).

| | | | | | | | | |
|--|-------------------|--------|--------|--------|---------|--------|--------|------------|
| (INCOMPLETE VEHICLE MANUFACTURED BY (VEHICULE INCOMPLET FABRIQUE PAR) NAVISTAR, INC. | | | | | | | | |
| G/P | | | | | | | | |
| V/N | XX,XXX KG | | | | | | | |
| W/B (| XX,XXX LB) | | | | | | | |
| R/V | | | | | | | | |
| | FRONT | AXLE | 2 | 3 | 4 | 5 | 6 | 7 |
| G/P | | | | | | | | |
| A/N | XX,XXX KG | XX,XXX | XX,XXX | XX,XXX | XX,XXX | XX,XXX | XX,XXX | XX,XXX KG |
| W/B (| XX,XXX LB) | XX,XXX | XX,XXX | XX,XXX | XX,XXX | XX,XXX | XX,XXX | XX,XXX LB) |
| R/E | | | | | | | | |
| VIN | 12345678901234567 | | | DATE | MM-YYYY | | | |

Figure ii.5 Incomplete Vehicle Information Labels

GOVERNMENT REQUIREMENTS

ADDITIONAL REQUIREMENTS

Canada

All Incomplete Vehicles manufactured and sold in Canada must also have a Canada National Safety Mark and National Emissions Mark affixed to the vehicle (reference Figure-ii.6).



Figure ii.6 Canada National Safety Mark and National Emissions Mark

Intermediate Manufacturer

Definition

Section 567.3 of Title 49 of the CFR defines an INTERMEDIATE MANUFACTURER as a person, other than the Incomplete Vehicle Manufacturer or Final Stage Manufacturer, who performs manufacturing operations on a vehicle manufactured in two or more stages.

Compliance Responsibility

In accordance with section 568.4 of Title 49 of the CFR, Navistar furnishes an Incomplete Vehicle Document (IVD) with each incomplete vehicle. Navistar will also affix an information label to the hinge pillar, door latch post, or door edge that meets the door latch post, next to the drivers seating position as specified in part 567.5 of Title 49 of the CFR.

In accordance with section 568.5 of Title 49 of the CFR each intermediate manufacturer is required to provide an addendum to the IVD for any modification

[↶ return to table of contents](#)

GOVERNMENT REQUIREMENTS

ADDITIONAL REQUIREMENTS

made by them to the incomplete vehicle that affects the validity of the compliance statements that appear in the IVD. The addendum must provide the name and mailing address of the intermediate manufacturer and specify the changes that must be made to the IVD to reflect the modifications that they made to the vehicle.

Final Stage Manufacturer

Definition

As defined by section 567.3 of Title 49 of the CFR, a FINAL – STAGE MANUFACTURER is a person who performs such manufacturing operations on an incomplete vehicle that it becomes a complete vehicle.

Compliance Responsibility

Section 568.6 of Title 49 of the CFR requires that the final – stage manufacturer shall complete the vehicle in such manner that it meets all applicable safety standards in effect on the date of manufacture of the incomplete vehicle, the date of final completion, or a date between these dates. It should be noted that a vehicle intended for use as a tractor, is not considered a complete vehicle until the fifth wheel has been installed.

When completed, the tractor must comply with all applicable Federal Motor Vehicle Safety Standards. Section 567.5 of Title 49 of the CFR stipulates that the Final Stage Manufacturer is responsible for installing an appropriate certification label that must be securely and permanently affixed to the completed vehicle.

For those situations when an entity other than a Navistar facility certifies a completed vehicle, that entity becomes the Final – Stage Manufacturer and has the option to create its own label or purchase a label from International service parts. Labels purchased from service parts do not have the name of the Final - Stage Manufacturer and information about the vehicle. This information has been left blank. Final – Stage Manufacturers that utilize the appropriate label and protective cover (435654C2) and provide the required information comply with the requirements specified by part 567 of Title 49 of the CFR. The label (see Figure-ii.7) is referred to as a “Final Stage Manufacturer Certification Label” and is identified with International part number 436076C4 for a vehicle sold in the U.S. or 1698980C2 for a vehicle sold in Canada.

GOVERNMENT REQUIREMENTS

ADDITIONAL REQUIREMENTS

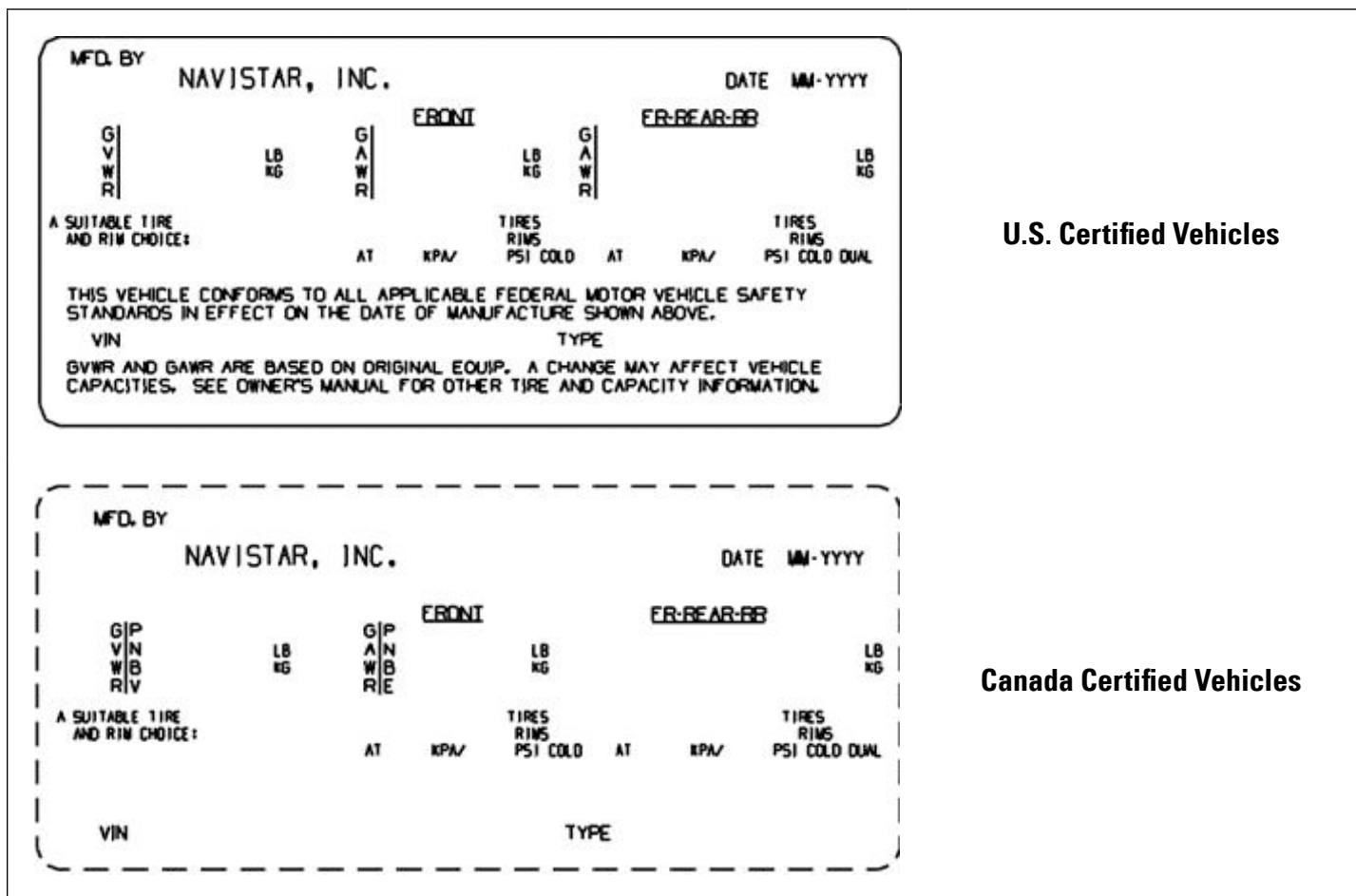

U.S. Certified Vehicles

Canada Certified Vehicles

Figure ii.7 Final Stage Manufacturer Certification Label

GOVERNMENT REQUIREMENTS

ADDITIONAL REQUIREMENTS

Canada

Certified Final – Stage Manufacturers of Canadian vehicles must affix the Canada National Safety Mark and National Emissions Mark with their identification number installed on it next to the final certification label shown above. Such authorization and identification number must be obtained from the Minister of Transport at Transport Canada. [Reference: Figure-ii.6 – “Canada National Safety Mark and National Emissions Mark”.]

Alterations To Completed Vehicles

Definition

Section 567.3 of Title 49 of the CFR defines an Altered Vehicle as a completed vehicle previously certified in accordance with section 567.4 or 567.5 that has been altered other than by the addition, substitution, or removal of readily attachable components or by minor finishing operations, before the first purchase of the vehicle other than for resale, in such a manner as may affect the conformity of the vehicle with one or more FMVSS or the validity of the vehicle’s stated weight ratings or vehicle type classification.

Compliance Responsibility

In accordance with section 567.7 of Title 49 of the CFR, if a person alters a certified vehicle before the first purchase of the vehicle other than for resale, the responsibility for compliance of the modified vehicle rests with the Alterer. The vehicle manufacturer’s Certification Label and any Information Labels shall remain affixed to the vehicle and the alterer shall affix an additional certification label that will supplement the certification label originally furnished with the vehicle by Navistar or the Final – Stage Manufacturer. This certification label must state the following:

“This vehicle was altered by (name of Alterer) in (month and year in which alterations were completed) and as altered it conforms to all applicable Federal Motor Vehicle Safety Bumper and Theft Prevention Standards affected by the alteration and in effect on the date of (no earlier than the date of manufacture of the certified vehicle as specified on the certification label and no later than the date alterations were completed).”

This label (Reference Figure-ii.8) is available from International service parts under Part No. 449893C5 for U.S. Certified Vehicles and Part No.1676840C3 for Canada Certified Vehicles. Protective cover 435654C2 should be installed over this label.

GOVERNMENT REQUIREMENTS

ADDITIONAL REQUIREMENTS

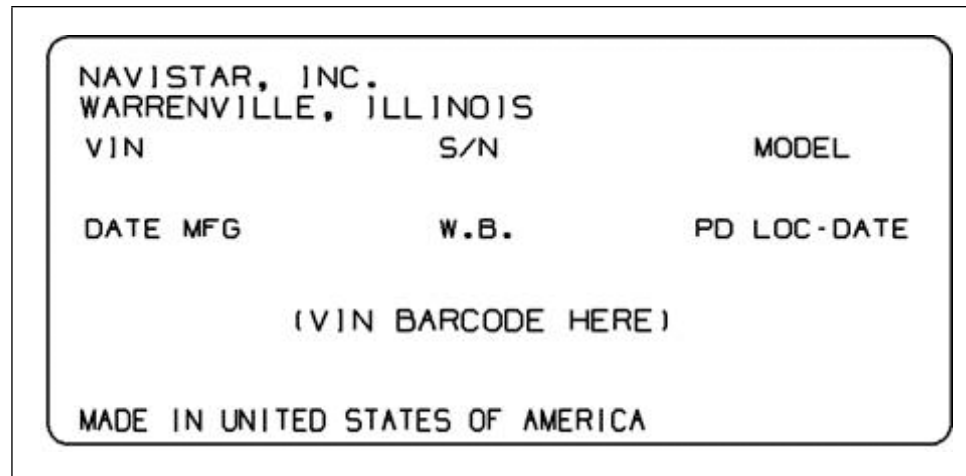

Figure ii.8 Vehicle Alterer Certification Label

Alterers of Canadian certified vehicles must apply the Canada National Safety Mark and National Emissions Mark, with their identification number, adjacent to the Vehicle Alterer Certification label. Such authorization and identification number must be obtained from the Minister of Transport at Transport Canada. [Reference Figure-ii.6 – “Canada National Safety Mark and National Emissions Mark”.

GOVERNMENT REQUIREMENTS

ADDITIONAL REQUIREMENTS

Exterior Noise Certification Label

Incomplete vehicles identified as chassis cabs by Navistar have the vehicle exterior noise label (Reference Figure-ii.9) permanently attached in a readily visible position in the operators compartment. For incomplete vehicles other than a chassis cab, the final stage manufacturer must assume responsibility and comply with EPA PART 205 SUBPART B, CMVSS 1106 – NOISE EMISSION FOR MEDIUM AND HEAVY TRUCKS.

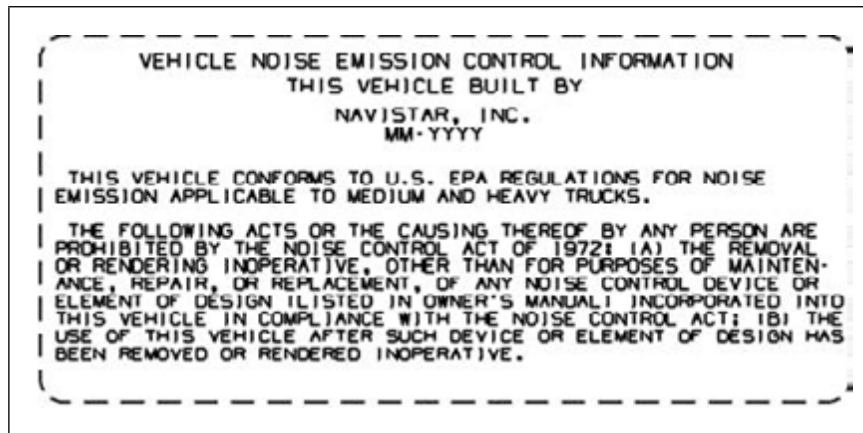

Figure ii.9 Vehicle Exterior Noise Label

Additional Certification Label Information and Instructions

- 1) All labels must be fully filled out.
- 2) All labels must be affixed to the vehicle in accordance with Sections 567 of Title 49 of the CFR or Canadian Motor Vehicle Safety Regulations, Sections 6 and 7.
- 3) No label shall be installed over another label.
- 4) It is unlawful to affix an incorrect certification label to a vehicle.

CAT

