

M 20 C

Long-Stroke Diesel Engines
for Maximum Efficiency
and High Reliability

6 • 8 • 9

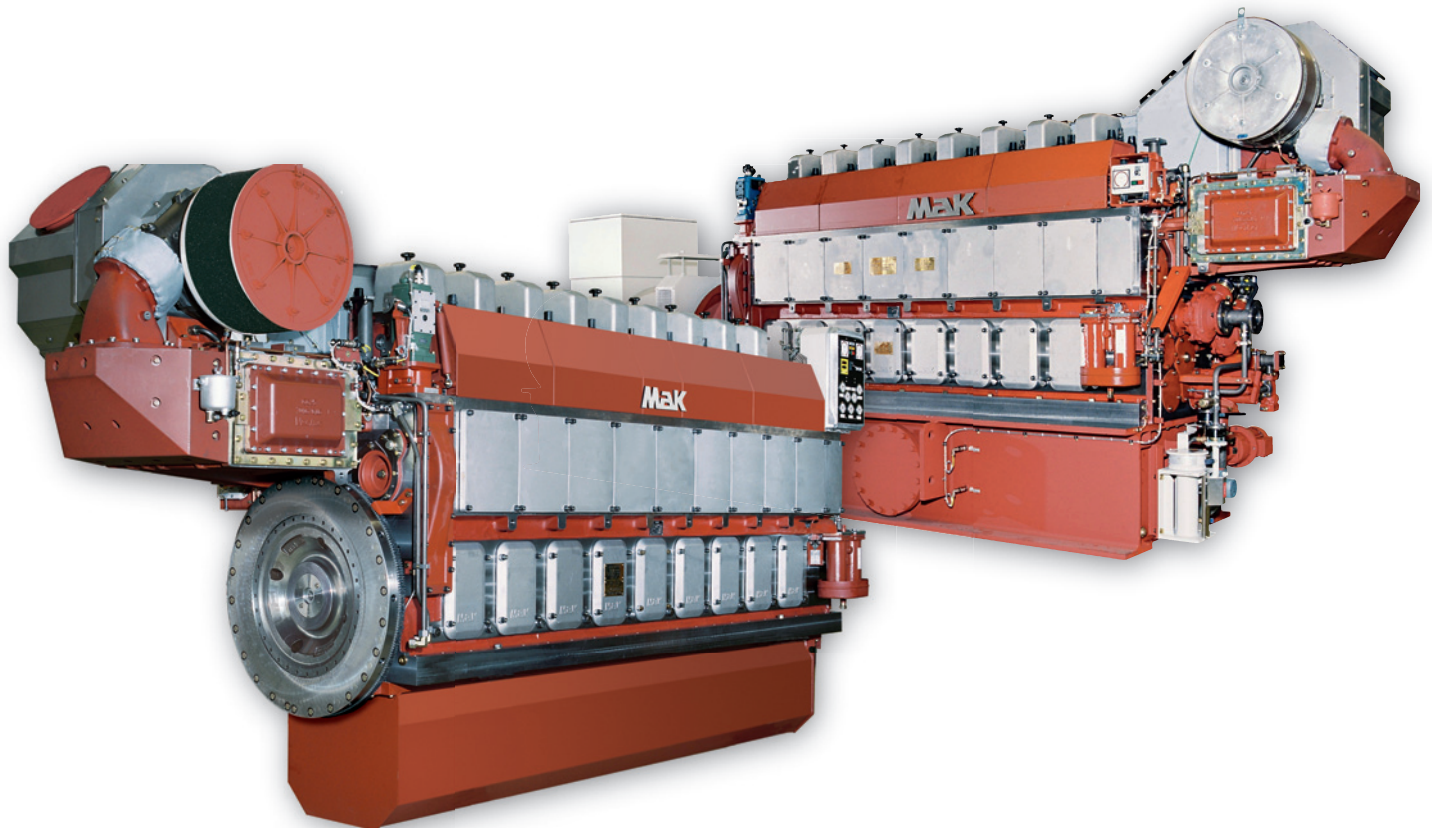

M 20 C – The Compact Long-Stroke Diesel Engine with Heavy Fuel Capability

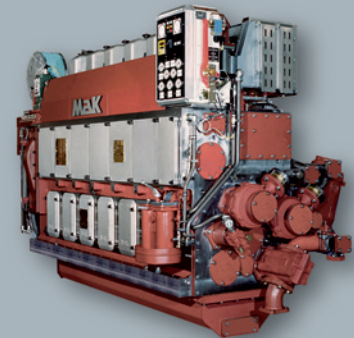

Launched in the 1990s, the M 20 series set a new milestone in MaK modern long-stroke engine technology.

Developed and designed in response to the special requirements of marine applications, the most striking features of this engine are its high reliability and economy. These features help to explain the continued high market demand for the M 20 C as an engine for both marine propulsion and marine generating sets.

The long-stroke design principle is the backbone of an excellent combustion process with low fuel and lube oil consumption, as

well low NO_x emission. The M 20 C engine is SOLAS compliant. Its intelligent simplicity means the high functional integration of fewer components. Fewer components mean greater reliability and easier maintenance.

Overall, this leads to outstandingly low operating costs and rapid returns on investment. Reliability and ease of maintenance are convincing arguments in favour of the engines of this series.



6, 8, 9

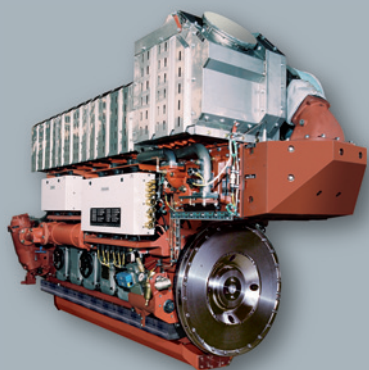
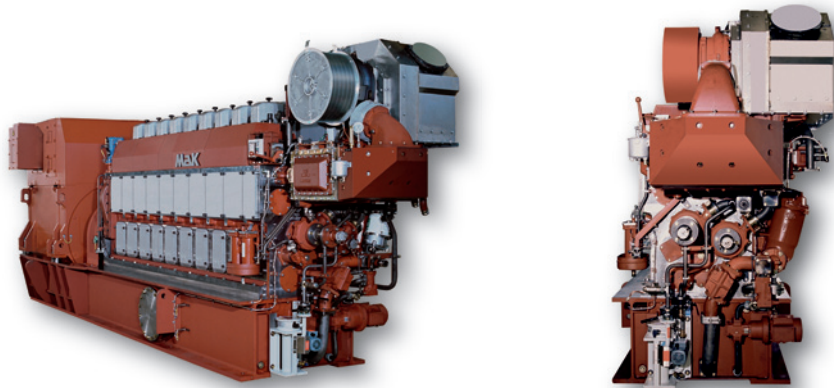

M 20 C – Marine Propulsion
M 20 C – On-Board Power
MaK Propulsion Package

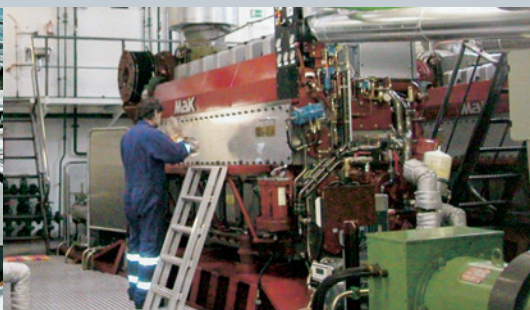

M 20 C – Design Improvement

Customer Benefits

- **Turbocharging System**
with improved efficiency
- **Exhaust Pipe Design**
for greater simplicity
- **Exhaust System Cladding**
small, compact and easy to maintain
- **Dual Circuit Fresh Water Cooling System**
for easier installation with higher efficiency
thanks to higher cooling water temperature
up to 90 °C

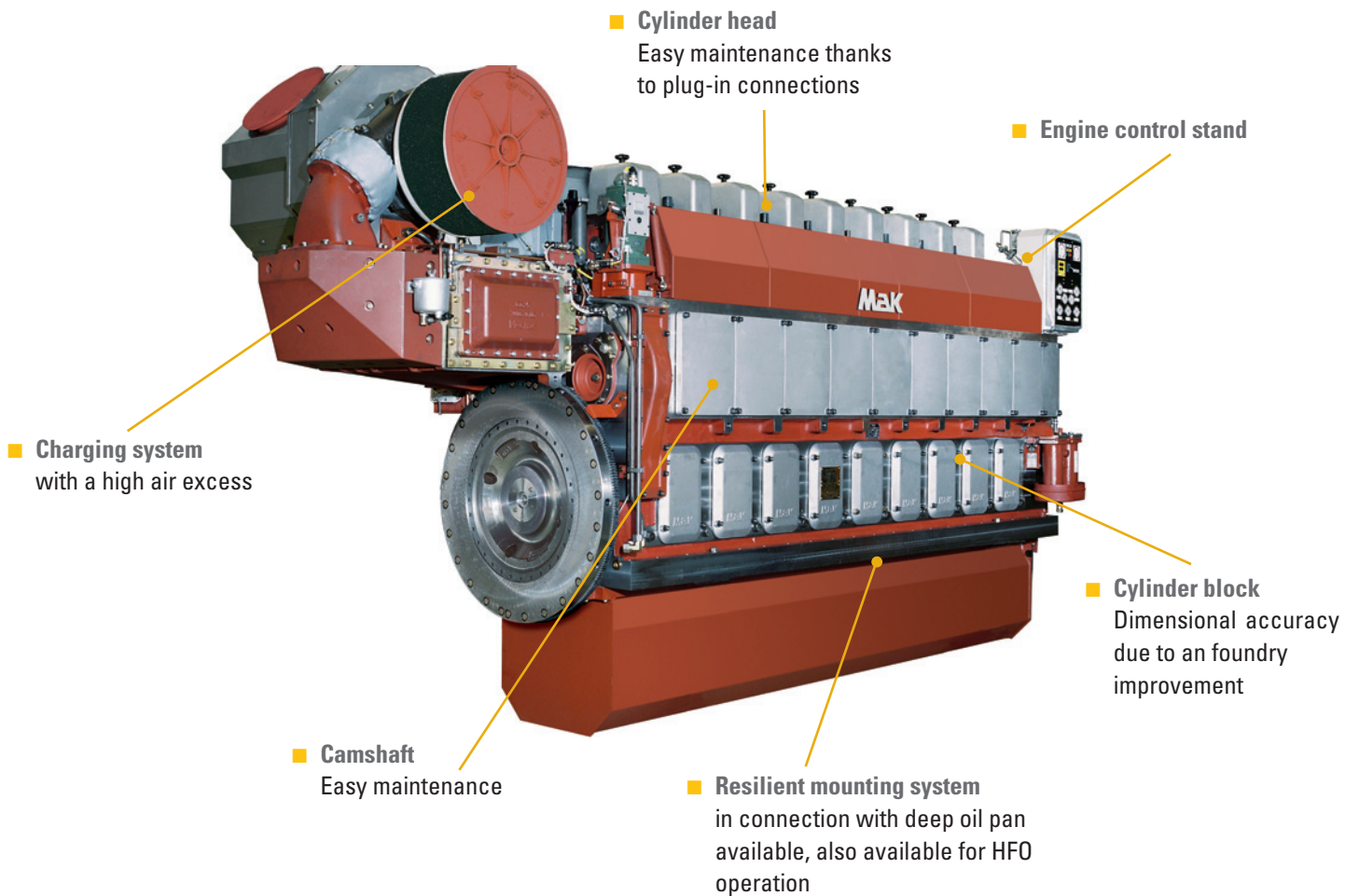

M 20 C – Design Features

Engine with high safety level

The M 20 C is an engine with a high safety level. This applies not only to those special internal design features which guarantee long component life and high availability but also to safety in the area around the engine. As a result, SOLAS regulations are strictly and consistently observed. Explosion protection cover for the cylinder/crankcase housing and cladding of the complete fuel and exhaust gas system in stainless steel are part of an overall SOLAS safety concept.

HFO/MDO – Long TBO and lifetime

Long maintenance intervals and the life of components are the basis for low operating costs.

	TBO x 1000 h	Lifetime x 1000 h
Piston crown	60	60
Piston skirt	-	60
Piston ring	-	30
Cylinder liner	-	60 / 90*
Cylinder head	15	90
Inlet valve	15	30
Exhaust valve	15	30
Nozzle element	-	5/ 7.5*
Pump element	-	15
Main bearing	-	30
Big-end bearing	-	30

*MDO Operation

The above mentioned data are not binding. They only serve as standard values. These standard values can be attained if the MaK operating and maintenance specifications are strictly observed and only MaK spare parts are used. Please consider as well the negative effect of bad fuel qualities.

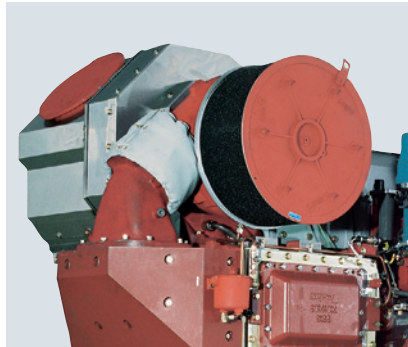

Charging system with a high air excess

- Rapid engine response
- Low temperature levels on components surrounding the combustion chamber
- Long turbocharger bearing life
- Turbocharger casing without water cooling. Safe and reliable. No corrosion.

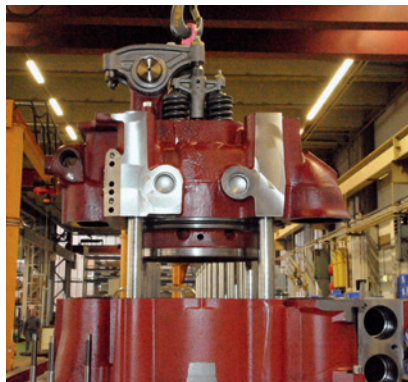

Cylinder head

- Inherent stability due to nodular cast iron, double-bottom construction
- Intensive cooling of the combustion chamber and exhaust valve seats
- Increased reliability due to integrated media ducts
- Easy maintenance thanks to plug-in connections and four hydraulically tightened studs



Engine control stand

- Reliable engine operation due to direct mounting of the control stand on the engine
- All control functions arranged directly on the engine

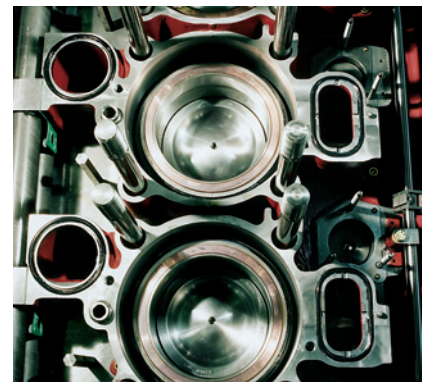

Cooling water ring

- Intensive cooling of the cylinder liner where cooling is needed
- Engine block free from coolant
- Coolant only circulates around the upper part of the cylinder liner and the cooling water ring

M 20 C – Design Features



Cylinder liner with anti-wear ring

- Long component life with a piston removal interval of 30,000 h under heavy fuel operation
- Extended lubricating oil change intervals
- Low overall operating costs

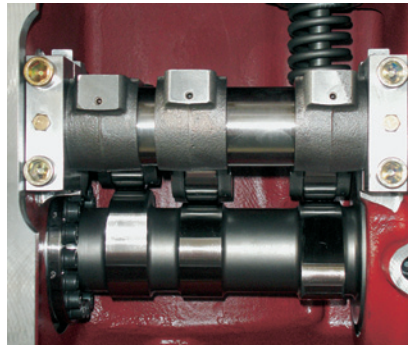

Camshaft

- Easy maintenance thanks to simple design
- Integrated non-adjustable cams for injection and valve timing
- Low wear thanks to cam follower lever arm arrangement

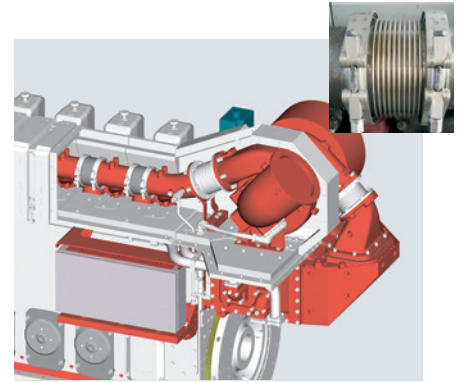

Exhaust pipe

- Single pipe exhaust line with modular construction
- Flow optimized pipe design for quick load acceptance
- Simplified maintenance due to clamped connection of individual modules

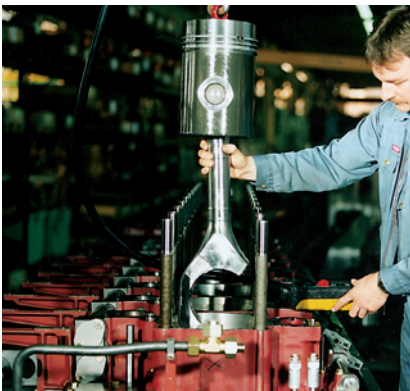

Piston

- Robust crown manufactured from forged steel with only two ring grooves
- First ring groove features with hardened surfaces
- Long aluminium skirt for favourable guidance
- Long piston ring service life
- Low cylinder liner wear

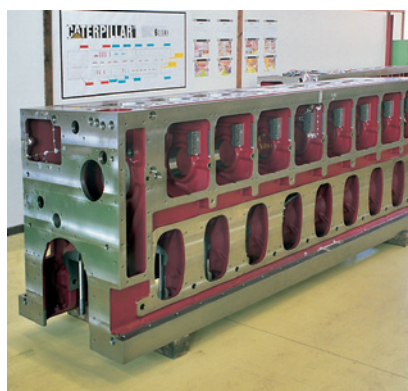

Engine block

- No cooling water in the engine block
- Firm base for main and camshaft bearings due to inherent rigidity
- Easy access for inspection and maintenance
- Safe mounting of engine on foundation
- Maintenance-friendly

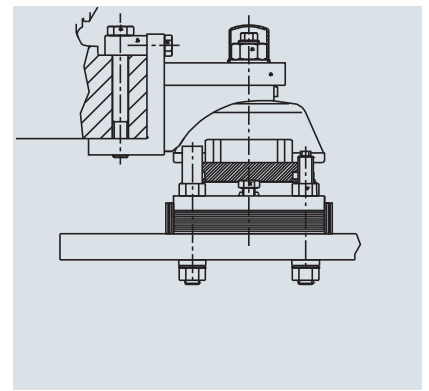

Resilient mounting system

Major components:

- Conical rubber elements isolate dynamic engine forces and structure-borne noise. Horizontal, lateral and vertical stoppers are combined to limit engine movement
- Dynamically balanced, highly flexible coupling
- Flexible connections for all media
- Specially designed exhaust gas bellows

M 20 C – Complete Diesel Generating Sets on a Common Base Frame

The main features of the diesel generating set are ease of installation, reliable operation, ease of maintenance and easy component accessibility. Its base is the rigid frame which forms a foundation for both the engine and the generating set and includes an integral, large-capacity oil sump and universal fuel supply equipment covering both HFO and MDO operation.

Generation of electricity

In addition to its use as a marine propulsion unit, the M 20 C has a wide range of application providing power for the continuous generation of electricity applications where a high level of reliability is always important. The power range of the M 20 C engine series as a generator unit is from 1,224 to 2,160 kVA.

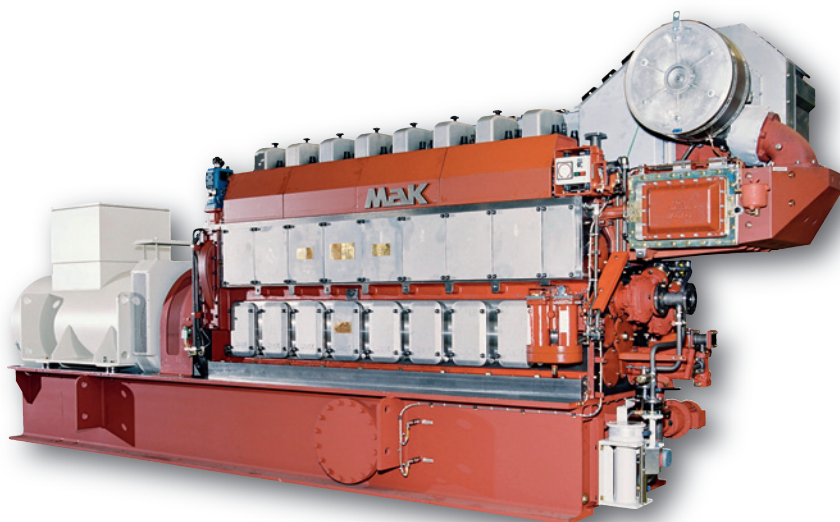

M 20 C – Technical Data

Complete engine

The engine is marketed with a standardized range of installed pumps and filters. Interfaces for fuel, lubricating oil and cooling water systems are located at the opposite end to the crankshaft coupling for ease of connection.

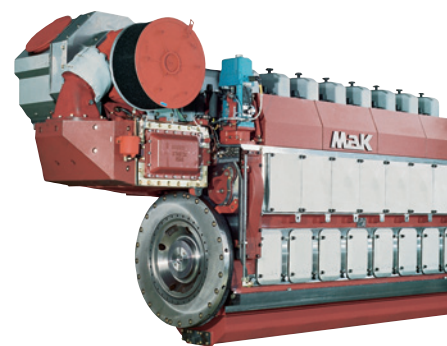

PROPULSION

Type	Output range	Speed	Mean eff. pressure	Mean piston Speed	Bore	Stroke	Spec. fuel consumption	
	kW	rpm	bar	m/s	mm	mm	100% g/kWh	85% g/kWh
6 M 20 C	1,020	900	24.1	9.0	200	300	189	188
	1,080	900	25.5	9.0	200	300	190	189
	1,140	1,000	24.2	10.0	200	300	190	189
	1,200	1,000	25.5	10.0	200	300	191	189
8 M 20 C	1,360	900	24.1	9.0	200	300	189	188
	1,440	900	25.5	9.0	200	300	190	189
	1,520	1,000	24.2	10.0	200	300	190	189
	1,600	1,000	25.5	10.0	200	300	191	189
9 M 20 C	1,530	900	24.1	9.0	200	300	189	188
	1,620	900	25.5	9.0	200	300	190	189
	1,710	1,000	24.2	10.0	200	300	190	189
	1,800	1,000	25.5	10.0	200 </tr			

Specific lubricating oil consumption 0.6 g/kWh, ± 0.3 g/kWh
LCV= 42700 kJ/kg, without engine-driven pumps, tolerance 5%

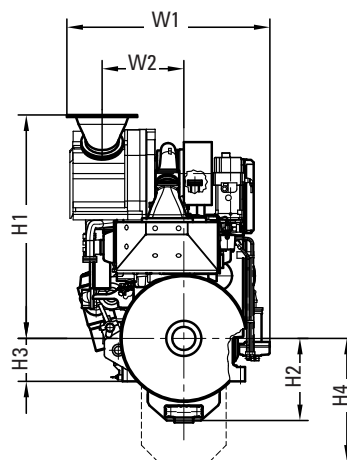
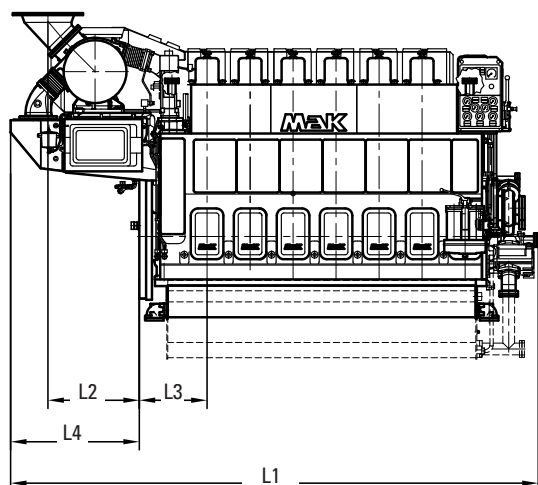

8

Propulsion engine (Dimensions in mm)

Engine	L1	L2	L3	L4	H1	H2	H3	H4	W1	W2	Weight (t)	
											wet sump	dry sump
6 M 20 C	4049	702	520	988	1714	630	330	941	1558	627	11.5	10.9
8 M 20 C	4846	802	520	1125	1856	630	330	941	1693	710	14.5	13.8
9 M 20 C	5176	802	520	1125	1856	630	330	941	1693	710	16.0	15.0

Wet sump (standard) Dry sump (special request)

Reliable energy supply

The complete diesel generating set is notable for its ease of installation, reliable operation, ease of maintenance and good component accessibility. The basis is formed by the rigid base frame as foundation of the engine and alternator with integrated oil sump, large oil volume and universal equipment for both HFO and MDO operation.

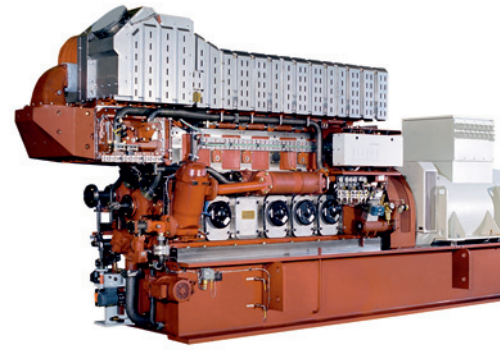

GENERATING SETS

Type	Engine rating		Output range	Frequency	Speed	Mean eff. pressure	Mean piston speed	Spec. fuel consumption	
	kW	kWe						kVA	Hz
6 M 20 C	1,020	979	1,224	60	900	24.1	9.0	189	188
	1,080	1,036	1,296	60	900	25.5	9.0	190	189
	1,140	1,094	1,368	50	1,000	24.2	10.0	190	189
	1,200	1,151	1,440	50	1,000	25.5	10.0	189	191
8 M 20 C	1,360	1,306	1,632	60	900	24.1	9.0	189	188
	1,440	1,381	1,728	60	900	25.5	9.0	190	189
	1,520	1,459	1,824	50	1,000	24.2	10.0	190	189
	1,600	1,534	1,920	50	1,000	25.5	10.0	191	189
9 M 20 C	1,530	1,468	1,836	60	900	24.1	9.0	189	188
	1,620	1,553	1,944	60	900	25.5	9.0	190	189
	1,710	1,641	2,052	50	1,000	24.2	10.0	190	189
	1,800	1,726	2,160	50	1,000	25.5	10.0	191	189

Bore: 200 mm
Stroke: 300 mm

Specific lubricating oil consumption 0.6 g/kWh, ± 0.3 g/kWh
LCV= 42700 kJ/kg, without engine-driven pumps, tolerance 5%
Generator efficiency: 0.96. $\cos\phi$: 0.8

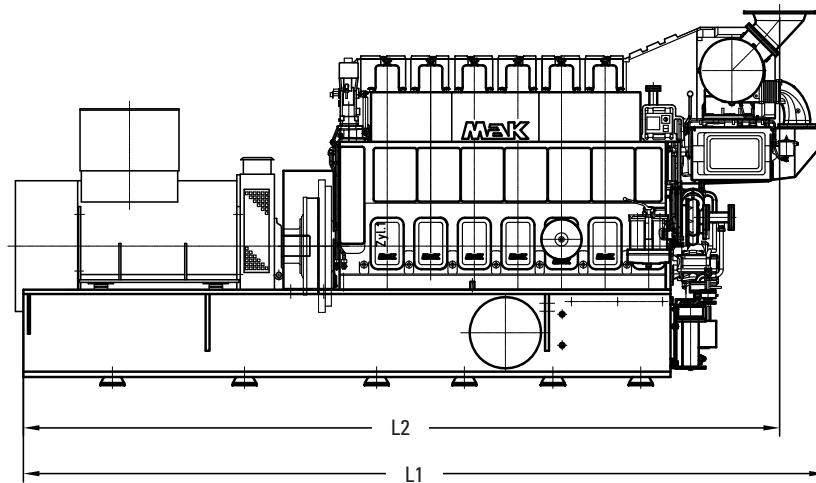
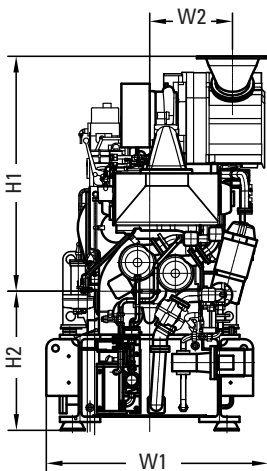

Generating set (Dimensions in mm)							
Engine	L1*	L2	H1	H2	W1	W2	Weight (t)
6 M 20 C	6073	5727	1779	1054	1680	627	18.8
8 M 20 C	6798	6475	1956	1054	1816	710	23.1
9 M 20 C	7125	6802	1956	1054	1816	710	26.0

*Dependent on generator make/type.

M 20 C – MaK Propulsion Package

Complete propulsion systems

The supply of complete propulsion systems is a market requirement which is becoming more and more important. We have wide experience gathered in the design and installation of many successful propulsion plants and from our close cooperation with competent partners.

We offer

- System responsibility and supply from a single source
- Accurately matched interfaces
- Coordinated delivery data control

A complete propulsion system usually consists of:

- MaK main propulsion engine with flexible coupling
- Reduction gearbox with or without installed clutch and gearbox PTO* with shaft generator
- Propeller and shaft installation
- Matched remote control and monitoring equipment

*Power Take Off

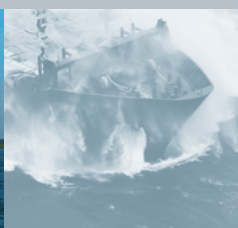
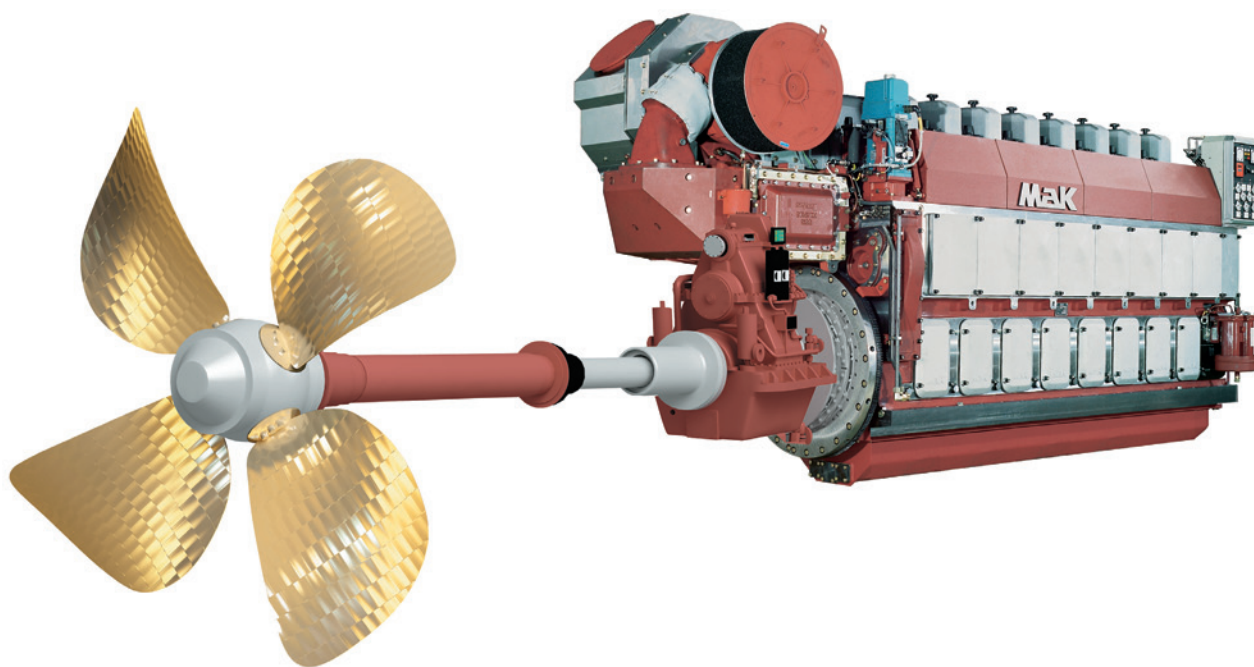

M 20 C – Clean Solution

The long-stroke concept for ecological operation

Environmental protection is also becoming increasingly important for seagoing shipping. Caterpillar Motoren recognized this trend in good time and, with the design and development of the modern long-stroke engine concept, created the conditions for engine operation at reduced emission levels. The NO_x emissions of the M 20 C engine lies well below the International Maritime Organisation's limiting curve.

The long-stroke concept for engine operation at reduced emission levels

The following features characterise the concept which ensures, in addition to smooth running, maximum operational reliability and also permits operation on heavy fuel oil up to 700 cSt/50°C.

- Long piston stroke
- Large stroke/bore ratio
- Intensive injection
- Shaped injection curve
- Optimised control times
- High ignition pressure

For MDO operation the engine is also available with less NO_x emission: Det Norske Veritas DNV "Clean Design" and Federal Ministry of Environment "Blue Angel".

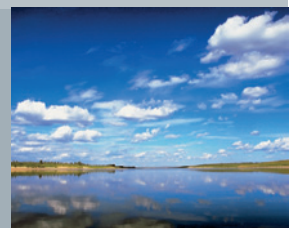
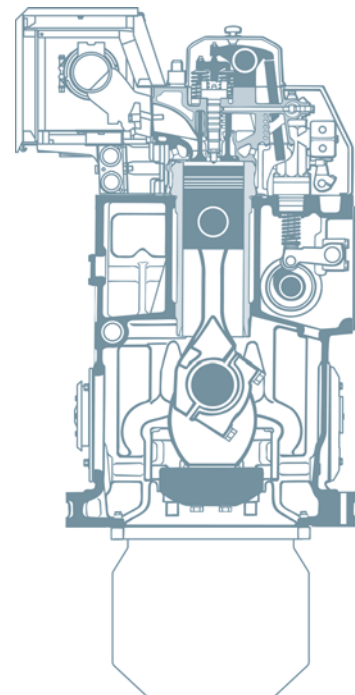
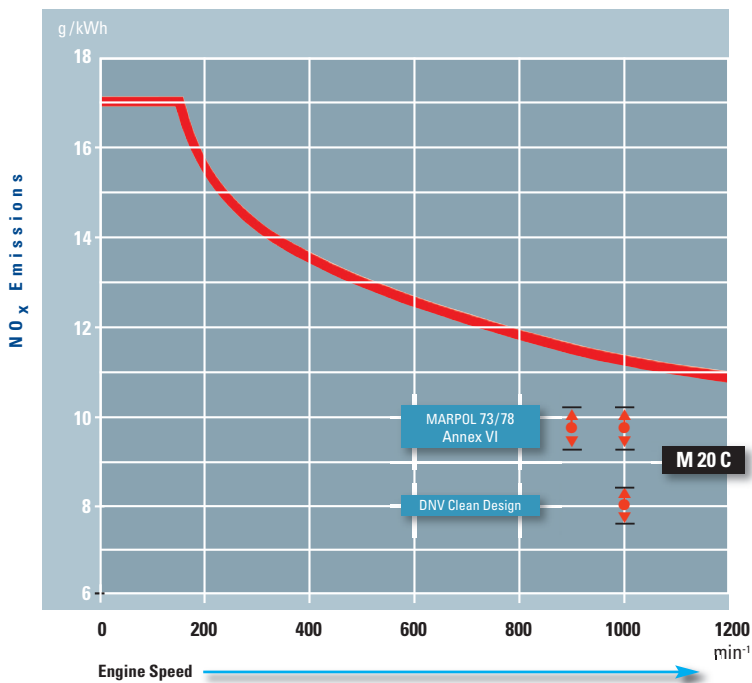

Cat Financial – World-Class Financing Solutions

You specify Cat or MaK power solutions, because you believe in the power of Caterpillar engines to keep you and your vessel safely on course. Cat Financial has the same commitment to your success – whether you need construction, term or repower financing.

We know how to support customers in one country, construction in a second country and registration in a third. We understand the marine industry – we’ve been lending to marine customers for nearly 30 years. And, as it has been since 1986, our service commitment is powered by Caterpillar and Cat and MaK dealers everywhere.

Global Coverage

Whether you’re a German operator building at a Chinese shipyard or a U.S. citizen building a yacht in Italy, Cat Financial can help. Our customers do business around the world, and we support them wherever they go.

Our service commitment extends to all marine sectors. From production and custom yachts to workboats and ocean-going vessels – we have you covered.

Local Presence

Need a local expert? We know local markets and how to navigate the legal and regulatory environments.

Cat Financial has offices in the Americas, Europe and Asia, and financing representatives all over the world. Put our knowledge to work to power the deal.

Get your project moving anywhere in the world with Cat Financial – backed by the power of Caterpillar and our unmatched dealer network.

Visit us online at
MARINE.CAT.COM/finance



Integrated Solutions – Product Support Portfolio



Commissioning



Customer Support Agreements (CSAs)



Training



Engine Upgrades



Brochures



Genuine Spare Parts



Maintenance



Remanufactured Parts



Overhauls/Repairs



Monitoring and Diagnostic Software

Providing integrated solutions for your power system means much more than just supplying your engines. Beyond complete auxiliary and propulsion power systems, we offer a broad portfolio of customer support solutions and financing options. Our global dealer network takes care of you wherever you are – worldwide. Localized dealers offer on-site technical expertise through marine specialists and an extensive inventory of all the spare parts you might need.

To find your nearest dealer, simply go to:
MARINE.CAT.COM

Perfect Solutions for Main Propulsion and On-Board Power Supply

The Program: Quality is our Motto. For more than 90 years we have developed, built, supplied and serviced diesel engines – worldwide. Today Caterpillar Marine with its brands Cat and MaK offer high-speed and medium-speed engines with power ratings from 93 kW to 14,400 kW. Many different engine families are available to meet your specific application needs.

Cat and MaK diesel engines are distinguished by high reliability, extremely low operational costs, simple installation and maintenance and compliance with IMO environmental regulations.

The application of engines in main and auxiliary marine power systems varies greatly and extends from high-speed boats and yachts, through tugs, trawlers and offshore vessels to freighters, ferries and cruise liners.

Sales and Service Organization

Caterpillar has combined the sales and service activities and responsibility of their Cat and MaK brand marine engine business into Caterpillar Marine Power Systems with headquarters in Hamburg/Germany.

In setting-up this worldwide structure, we have concentrated on integrating the Cat and MaK brand groups into a single, united marine team, which utilises the particular expertise of each group.

Commercial marine engine business is split into three geographic regions,

- Europe, Africa, Middle East
- Americas ■ Asia-Pacific,

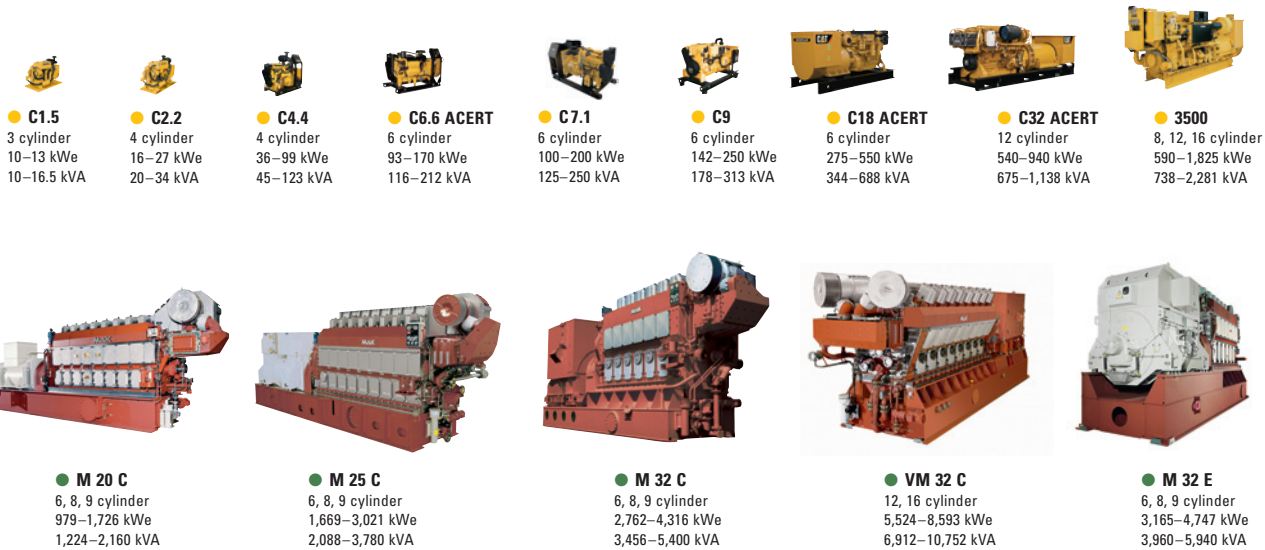

14



Propulsion Engines

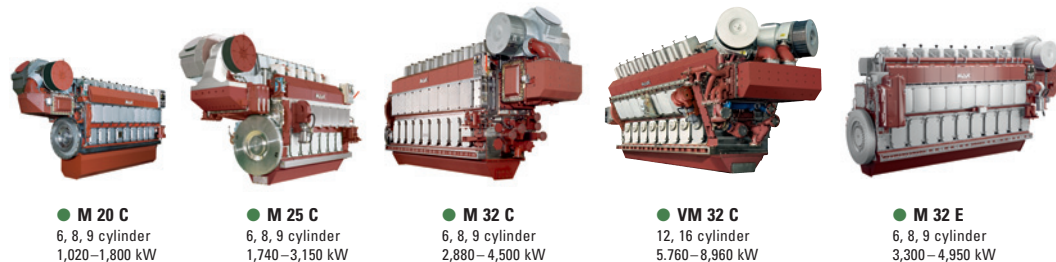

Production Facilities

which manage all sales and product support activities. They have direct responsibility for achieving the ambitious growth targets set for the Cat and MaK brands and for providing our customers and dealers with complete marine solutions.

Caterpillar's global dealer network provides a key competitive edge – customers deal with people they know and trust.

Cat dealers strive to form a strong working relationship with their customers, offering comprehensive and competent advice from project support to repair work.

Some of the most advanced manufacturing concepts are used at Caterpillar locations throughout the world to produce engines in which reliability, economy and performance are second-to-none.

From the production of core components, the assembly of engines to the delivery of complete propulsion packages, quality is always the top priority.

Comprehensive, recognized analysis systems, test procedures and measuring

methods ensure that quality requirements are met throughout all the individual manufacturing phases. All of our production facilities are certified under 1:2000 ISO 9001 EN, the international benchmark that is helping to set new quality standards worldwide.

In addition to product quality, our customers expect comprehensive service which includes the supply of spare parts throughout the life of the engine.

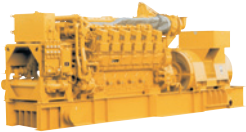

● **C280**
6, 8, 12, 16 cylinder
1,650–5,200 kW
2,063–6,500 kVA

Onboard Power Supply

- High-Speed Engines
- Medium-Speed Engines



● **M 34 DF**
6, 8, 9 cylinder
2,877–4,316 kW
3,600–5,400 kVA

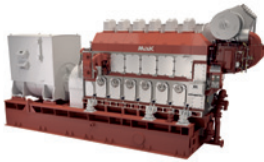

● **M 43 C**
6, 7, 8, 9 cylinder
5,179–9,063 kW
6,480–11,340 kVA



● **VM 43 C**
12, 16 cylinder
10,357–16,111 kW
12,960–20,160 kVA

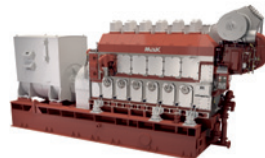

● **M 46 DF**
6, 7, 8, 9 cylinder
5,179–7,768 kW
6,480–9,720 kVA

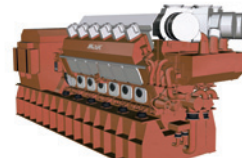

● **VM 46 DF**
12, 16 cylinder
10,357–13,810 kW
12,960–17,280 kVA



● **C32 ACERT**
12 cylinder
492–1,417 kW



● **3500**
8, 12, 16 cylinder
526–2,525 kW



● **C175**
16 cylinder
2,001–2,168 kW



● **C280**
6, 8, 12, 16 cylinder
1,730–5,650 kW

- High-Speed Engines
- Medium-Speed Engines



● **M 34 DF**
6, 8, 9 cylinder
3,000–4,500 kW

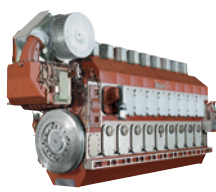

● **M 43 C**
6, 7, 8, 9 cylinder
5,400–9,450 kW

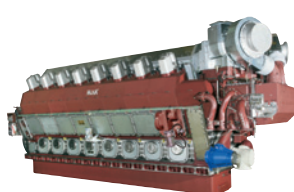

● **VM 43 C**
12, 16 cylinder
10,800–16,800 kW



● **M 46 DF**
6, 7, 8, 9 cylinder
5,400–8,100 kW

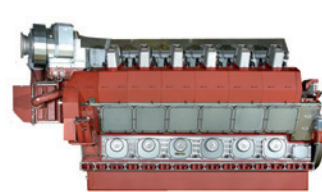

● **VM 46 DF**
12, 16 cylinder
10,800–14,400 kW

Caterpillar Marine Power Systems

Headquarters

Caterpillar Marine Power Systems
A Division of
Caterpillar Motoren GmbH & Co.KG
Neumühlen 9
22763 Hamburg/Germany

Phone: +49 40 2380 3000
Telefax: +49 40 2380 3535

Europe, Africa, Middle East

Caterpillar Marine Power Systems
A Division of
Caterpillar Motoren GmbH & Co.KG
Neumühlen 9
22763 Hamburg/Germany

Phone: +49 40 2380 3000
Telefax: +49 40 2380 3535

Americas

MaK Americas Inc.
3450 Executive Way
Miramar Park of Commerce
Miramar, FL 33025/USA

Phone: +1 954 885 3200
Telefax: +1 954 885 3131

Asia Pacific

Caterpillar Marine Trading (Shanghai) Co., Ltd.
25/F, Caterpillar Marine Center
1319, Yan'an West Road
200050 Shanghai/P. R. China

Phone: +86 21 6226 2200
Telefax: +86 21 6226 4500

Caterpillar Marine Asia Pacific Pte Ltd
No. 5 Tukang
Innovation Grove
Singapore 618304
Republic of Singapore

Phone: +65 68287 600
Telefax: +65 68287 625

For more information please visit our website:
MARINE.CAT.COM

Subject to change without notice.
Leaflet No. 226 · 08.13 · e · L+S · VM3

© 2013 CAT, CATERPILLAR, their respective logos, MaK, "Caterpillar Yellow" and the "Power Edge" trade dress, as well as corporate and product identity used herein, are trademarks of Caterpillar and may not be used without permission.



Caterpillar Marine Power Systems is committed to sustainability. This document is printed on PEFC certificated paper.



Please check out
the MaK M20 C Project Guide
by scanning the QR code

The MaK logo, consisting of the letters 'MaK' in a bold, green, sans-serif font.