

POWER PRODUCTS

TWO CYCLE ADVANTAGE

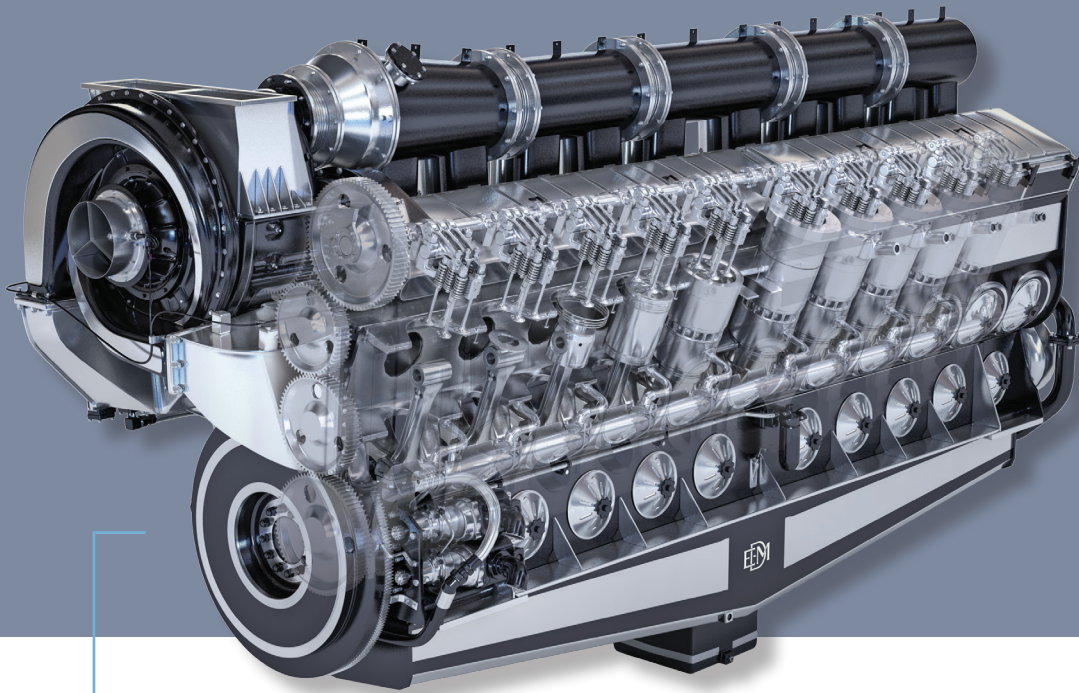

TWO CYCLE ADVANTAGE
ENDURING DESIGN.
LEGENDARY HERITAGE.

The E 23 engine available in 8, 12, 16 and 20 cylinder configurations with continuous power ratings from 2000 to 5000 hp

E 23 Engine Ratings and Configurations

Engine	900 RPM		800 RPM		720/750 RPM	
	BKW	BHP	BKW	BHP	BKW	BHP
8 E 23	1491	2000	1312	1760	1249	1675
	1864	2500				
12 E 23	2237	3000	1976	2650	1861	2495
16 E 23	2983	4000	2629	3525	2479	3325
20 E 23	3729	5000	3281	4400	3098	4155

ENGINES AVAILABLE IN THESE CONFIGURATIONS
 Marine applications
 Stationary power applications
 Drilling applications meeting
 MODU inclination requirements

By adhering to a tenacious balance of innovation and refinement, Electro-Motive Diesel (EMD) has proudly grown our exclusive medium speed two-cycle engine design into one of the longest lasting medium speed engine families in the world. To date, EMD has delivered over 78,000 engines of this core design into industry since 1935 with more to come to meet forthcoming environmental regulations and fuel choices.

Today's model, the EMD E 23, is also supported by the strongest dealer network in the world.
Advantage EMD.

EMD ENGINES ARE CERTIFIED BY



MODERN FUEL ADVANTAGE

DIESEL

The E 23 has met the challenges of increasing stringent global emissions standards through continuous optimization and refinement of its proven design, resulting in the most efficient and durable marine engine in its class. True to this philosophy, the E 23 utilizes mature, proven emissions reduction technologies to meet US EPA Tier 4F and IMO III, so customers have maximum confidence in the engine and minimum risk in daily operations.

DUAL FUEL

Dynamic Gas Blending® provides ability to substitute diesel fuel usage with natural gas at rates as high as 80%, while allowing operation with 100% diesel fuel if needed. The engine seamlessly transitions from diesel to gas with no operator interaction. EMD's patented DGB® conversion kits have been engineered to be fully compatible with some existing EMD engines. DGB® maintains over 90% parts commonality without compromising power output, transient response, and the reliability of the diesel original.

NATURAL GAS

Available in 2017, the EMD E 23 engine will offer diesel substitution with natural gas at rates of 95% or higher through its exclusive High Pressure Direct Injection (HPDI) technology. HPDI is also designed as a conversion kit for some existing EMD engines; this advanced technology will allow owners to realize the lowest operating costs and minimize environmental impact. HPDI retains existing mechanical propulsion drive lines by leaving horsepower, torque, and transient response identical to the diesel original.



Escort/ship assist tug
powered by the E 23 engine.



TRANSIENT RESPONSE ADVANTAGE

MAXIMUM POWER.

MINIMUM TIME.

VARIABLE SPEED PROPULSION

Power Capability and Margin

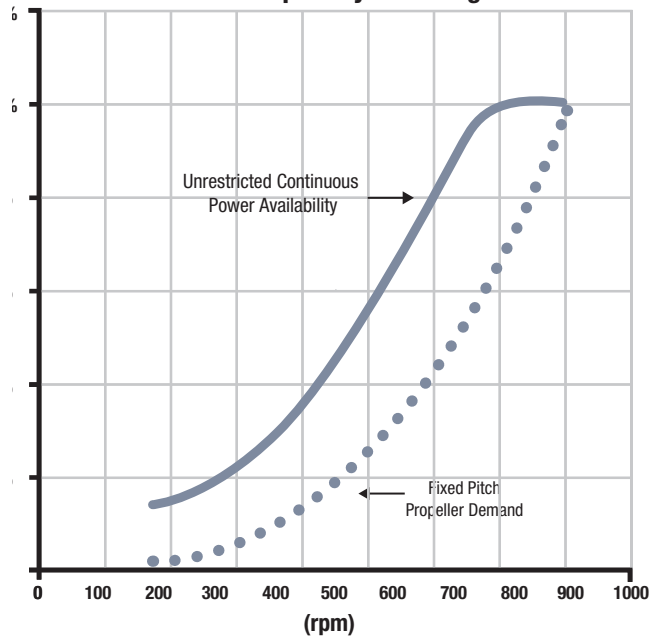

Transient Performance

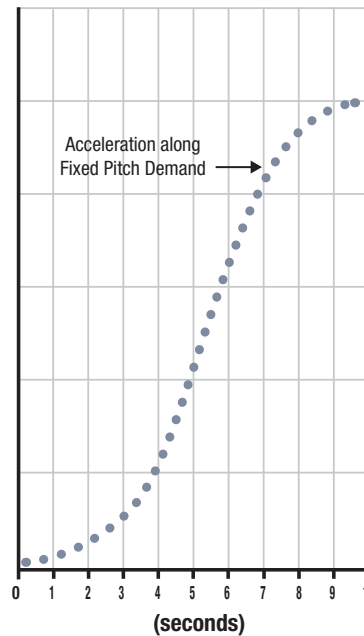

The stakes are high in your operation, and you cannot afford to wait for engine power delivery when fractions of a second count. Cool, high density charge air delivered to the E 23 cylinders across the entire operating range enables rapid power response regardless of the operating point. This allows the E 23 to accelerate from idle (200 RPM) to 100% continuous load and speed (900 RPM) in approximately 10 seconds for most fixed pitch applications. This benchmark performance is also key to the E 23's superior fuel efficiency.

Maximum air-fuel ratio across an industry leading operating speed range minimizes injected fuel at each combustion cycle, minimizing operating cost and environmental impact.

SIMPLE POWER MANAGEMENT WITH FULL POWER IN UNDER ONE SECOND.



The same feature that enables the E 23's superior variable speed transient response also benefits synchronous speed diesel electric applications. 100% block load capability in the form of 4% maximum frequency dip and return to 100% synchronous speed in 500 milliseconds opens a new level of simplicity for design of your power management system.

This near instantaneous availability of full output minimizes the size and footprint of your installed electrical power and eliminates many cases of load shedding normally needed to protect bus frequency from slower responding generator set engines.

CONSTANT SPEED DIESEL ELECTRIC

The E 23 at work

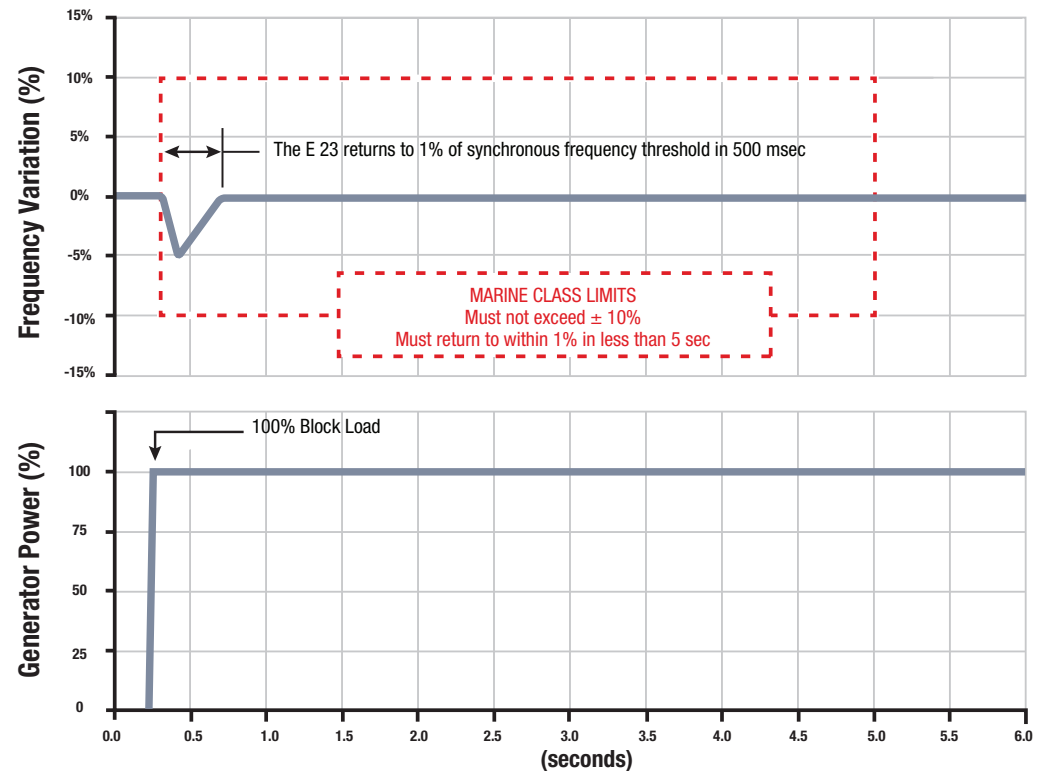

DURABILITY ADVANTAGE

PARTS THAT LAST.

SIMPLE TO MAINTAIN.

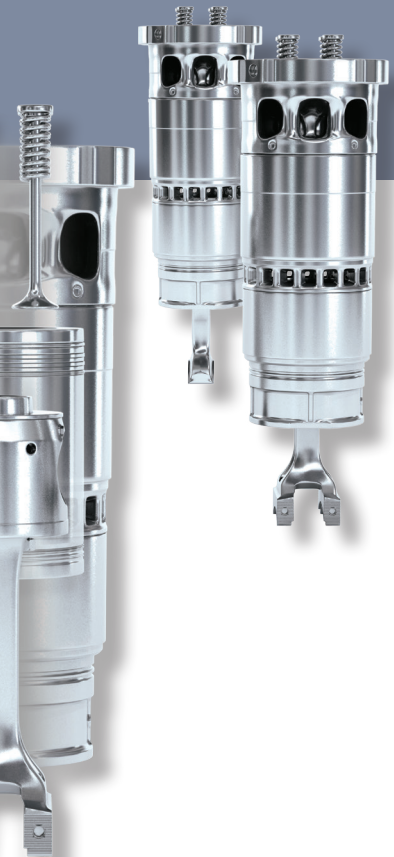

The world class durability of the E 23 is more than a design goal; it is an EMD standard. The uniflow-scavenged two cycle design unique to the E 23 engine allows customers to realize superior engine reliability and the highest possible uptime.

Combustion at every crankshaft revolution results in low firing pressures and smooth power output. This keeps stresses in critical engine components to a minimum resulting in high durability.

Smoother combustion translates into very low vibration energy transfer into the vessel structure, directly improving the comfort of your crew and the reliability of your vessel.

SERVICEABILITY ADVANTAGE – Low operating stress inherent to the E 23 two cycle design results in service components with a distinctive combination of light weight and unmatched durability. Service and overhaul of the complete engine requires only traditional hand tools without the need or expense of hydraulic tensioning equipment.

Complete cylinder power assemblies (cylinder head + cylinder liner + piston + connecting rod) can be replaced in less than four hours. Kilowatt for Kilowatt, no medium speed engine can be overhauled in less time than the E 23.

LIFE CYCLE ADVANTAGE
MINIMUM FUEL CONSUMPTION.
LOW MAINTENANCE.



E 23 powered
triple screw towboat

LOW MAINTENANCE, BY DESIGN – This is standard operation for the E 23. Thanks to the same design for low stress that enables its world class durability, the E 23 further minimizes your planned downtime by eliminating any need for cylinder head replacement or service at mid-life.

Superior component life, maximum time between overhaul, and minimum downtime make the E 23 the lowest cost medium speed engine.



PREDICTIVE MAINTENANCE – Because the E 23 integrates the intake air manifold into the engine crankcase, a complete qualitative and quantitative assessment of all critical internal components can be performed in two hours without removal from the engine.



Predictive Maintenance - Replace parts only when needed. Save time and money.

Piston ring clearances, cylinder liner condition and more can be evaluated quickly with one revolution of the crankshaft.

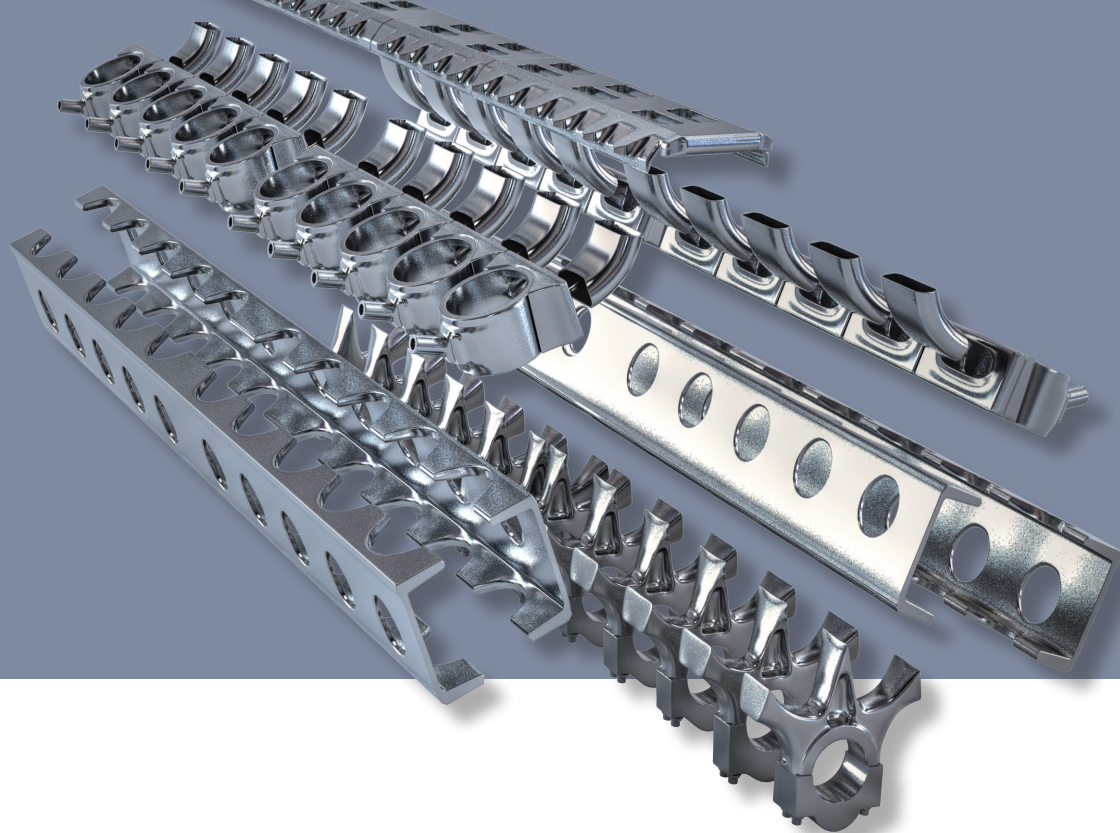

PRODUCT SUPPORT ADVANTAGE COMMITMENT WORLDWIDE.

EMD emission kits are the result of extensive development and testing in the same engineering facilities where our new Marine engines are designed, built, and tested.

EMD Emission Reduction Overhaul Kits

(US EPA 1042 Certified)

	Basic Reduction Kit*	UL® Reduction Kit*	Advanced Reduction Kit
Lube Oil Consumption	25% ↓	50% ↓	50% ↓
PM	25% ↓	50% ↓	50% ↓
NOx			40% ↓

* Additional benefit of up to 3% fuel consumption savings
All changes are estimated from original baseline engine configuration (E3 duty cycle)

With over 78,000 engines in service around the world, EMD is committed to supporting your equipment whether you are the first or fifth owner of the engine. As an OEM, EMD continuously improves parts quality, reliability, and availability to keep your engine running – keeping your company profitable. EMD has superior product support – offering cost saving upgrades to engines produced over the last 50 years.

With factory and dealer inventory to support your engine wherever it operates, only genuine EMD parts provide the quality, durability, and proven performance to maximize your uptime.



DEALER ADVANTAGE

With over 18 dealers and hundreds of service locations your EMD engine has parts and technicians ready to serve your immediate needs. All technicians are factory trained and will keep your EMD engine hard at work.





EMD E 23 ENGINE TECHNICAL SPECIFICATIONS.

Ferry operators
specify the E 23

E 23 MARINE ENGINE SHOWN

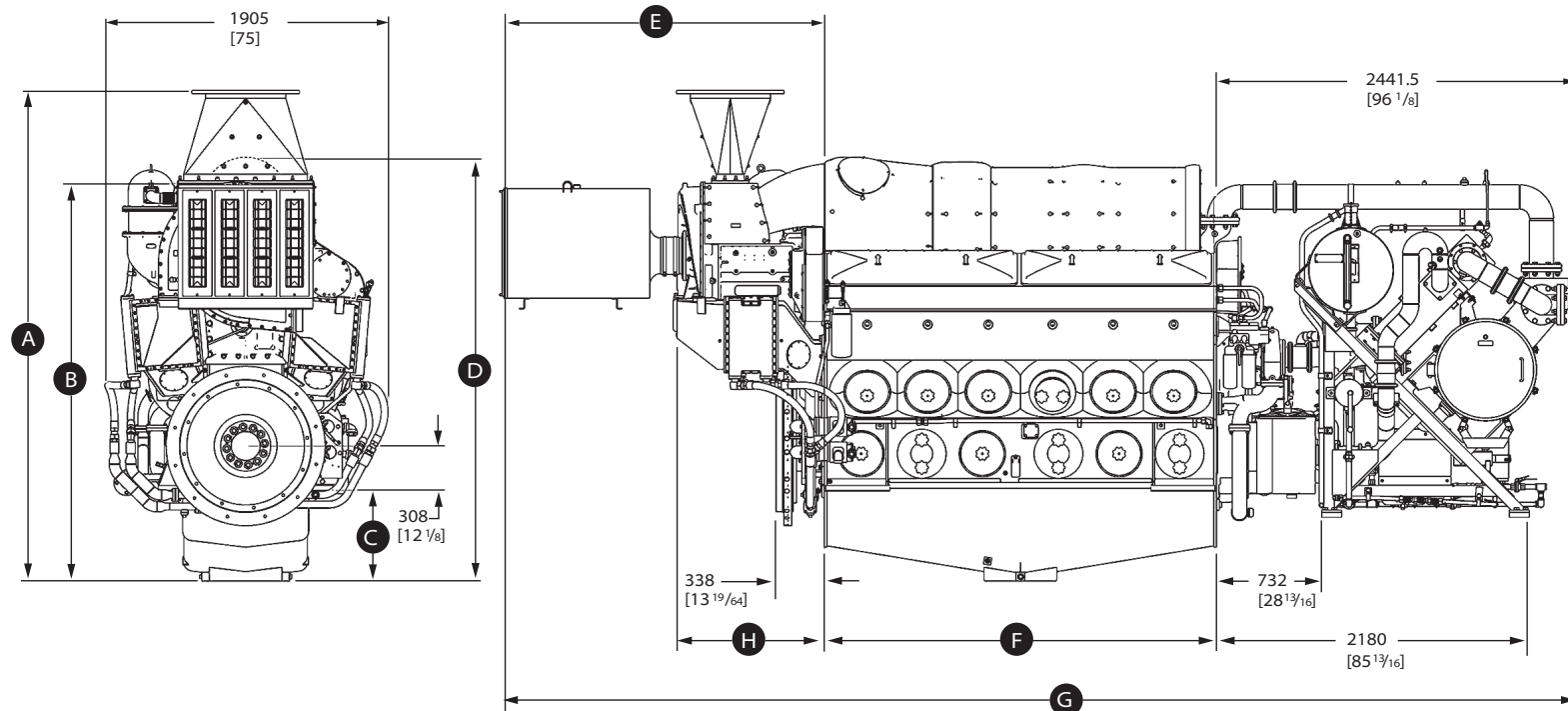



MARINE ENGINE MODEL	A HEIGHT - BOTTOM OIL PAN TO 180° EXHAUST OUTLET		B HEIGHT - BOTTOM OIL PAN TO TURBO EXHAUST OUTLET		C DEPTH - MOUNTING PADS TO OIL PAN BOTTOM		D HEIGHT - OIL PAN BOTTOM TO TOP EXHAUST BLANKET		E LENGTH - FINISH FACE OF ENGINE TO AIR FILTER INLET	
	METRIC	US STD	METRIC	US STD	METRIC	US STD	METRIC	US STD	METRIC	US STD
8 E 23	3.246 M	10' 7-13/16"	2.573 M	8' 5-5/16"	0.479 M	18' 7/8"	2.790 M	9' 1-7/8"	2.134 M	7'
12 E 23	3.410 M	11' 2-1/4"	2.764 M	9' 0"	0.632 M	24' 7/8"	2.948 M	9' 8-1/16"	2.240 M	7' 4-3/16"
16 E 23	3.410 M	11' 2-1/4"	2.764 M	9' 0"	0.632 M	24' 7/8"	2.948 M	9' 8-1/16"	2.240 M	7' 4-3/16"
20 E 23	3.642 M	11' 11-3/8"	2.573 M	9' 8-13/16"	0.835 M	32' 7/8"	3.150 M	10' 4"	2.240 M	7' 4-3/16"

MARINE ENGINE MODEL	F LENGTH FINISH FACE OF CRANK CASE		G LENGTH - AIR FILTER TO END OF ACCESSORY RACK		H LENGTH - FINISH FACE OF ENGINE TO TURBO INLET		WEIGHTS (DRY)			
	METRIC	US STD	METRIC	US STD	METRIC	US STD	ENGINE		ACCESSORY RACK	
	METRIC	US STD	METRIC	US STD	METRIC	US STD	METRIC	US STD	METRIC	US STD
8 E 23	1.864 M	6' 1-3/8"	6.202 M	20' 4-5/32"	0.929 M	36.59"	13,018 KG	28,700 LBS	1,723 KG	3,800 LBS
12 E 23	2.734 M	8' 11-5/8"	7.178 M	23' 6-19/32"	1.050 M	41.34"	17,690 KG	39,000 LBS	1,723 KG	3,800 LBS
16 E 23	3.715 M	12' 2-1/4"	8.171 M	26' 9-11/16"	1.050 M	41.34"	20,865 KG	46,000 LBS	1,723 KG	3,800 LBS
20 E 23	4.559 M	14' 11-1/2"	2.573 M	29' 6-15/16"	1.050 M	41.34"	23,949 KG	52,800 LBS	1,769 KG	3,900 LBS



From a dealer network that works closely with EMD performance and application engineers to design, install and service systems world-wide...to a service center organization that provides OEM parts from multiple warehouse locations and expertly trained mechanics around the world... to classroom training at our state of the art training facility... you can depend on EMD to provide what our customers want and the competition can't.

ELECTRO MOTIVE

9301 West 55th St. LaGrange, IL 60525 708.387.6000 progressrail.com/powerproducts
Electro-Motive Diesel is owned by Progress Rail Services, A Caterpillar Company