

PRENTICE

**2344 • 2346 • 2546 • 2548
Forwarders**



Built Better Than It Needs To Be

Prentice forwarders are designed for dependable production no matter the terrain or job situation. Robust construction, proven Cat® diesel engines and reliable, high flow hydraulic systems give you the performance you need to get the job done. Prentice forwarders have proven, over-sized components including heavy-duty axles and torque converter power shift transmissions. The spacious, comfortable operator stations are designed for exceptional visibility.



Power Train

- Field-proven CAT C4.4 and C6.6 ACERT diesel engines
- Torque converter power shift transmission
- 4-speed electronic shift
- Wet disc axle and parking brakes

Control System

- IQAN computer control system on 2546 & 2548 models
- Closed center proportional control valves
- Hydraulic oil cooler with thermal bypass

Operator Station

- Scratch resistant 1.27 mm (1/2 in) tinted polycarbonate windows
- Side windows double as emergency escape routes
- Heater/air conditioner
- Fire extinguisher
- 360° lighting package
- Hydraulic tilt cab
- Isolation mounted cab

FORWARDER BASIC DIMENSIONS

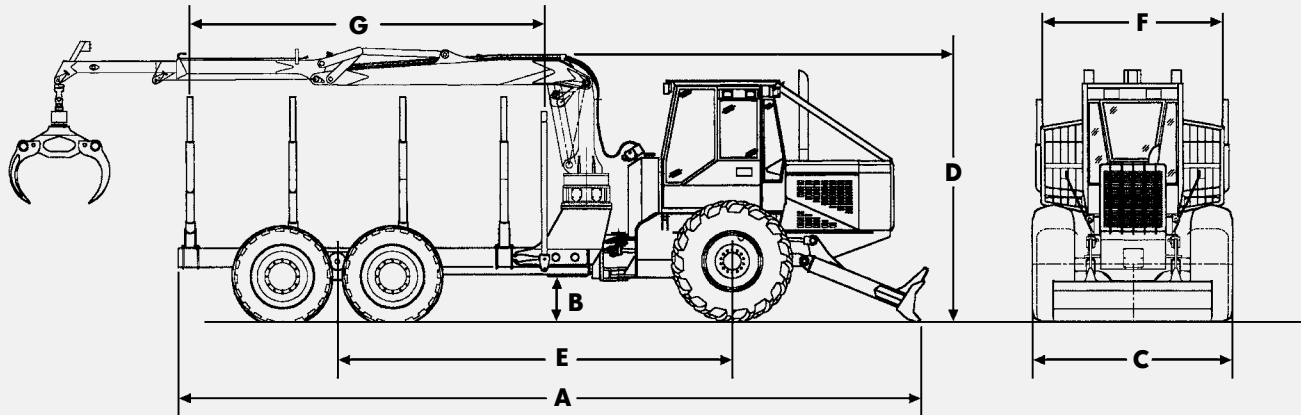

	2344	2346	2546	2548
A Overall Length				
2.92m (9.6') bunk	7849mm (309 in)	n/a	n/a	n/a
3.35m (11.5') bunk	8433mm (332 in)	n/a	n/a	n/a
4.88m (16') bunk	9880mm (389 in)	9754mm (384 in)	10.21m (402 in)	10.21m (402 in)
5.64m (18.5') bunk	n/a	n/a	10.97m (432 in)	10.97m (432 in)
B Ground Clearance	549mm (21.6 in)	579mm (22.8 in)	579mm (22.8 in)	579mm (22.8 in)
C Width with Standard Tires	2642mm (104 in)	2642mm (104 in)	2997mm (118 in)	3048mm (120 in)
D Transport Height	3454mm (136 in)	3581mm (141 in)	3581mm (141 in)	3581mm (141 in)
E Wheel Base				
2.92m (9.6') load deck	3835mm (151 in)	n/a	n/a	n/a
3.35m (11.5') load deck	4394mm (173 in)	n/a	n/a	n/a
4.88m (16') load deck	5385mm (212 in)	5334mm (210 in)	5334mm (210 in)	5334mm (210 in)
5.64m (18.5') load deck	n/a	n/a	5715mm (225 in)	5715mm (225 in)
F Load Stake Width (inside)	2362mm (93 in)	2362mm (93 in)	2591mm (102 in)	2591mm (102 in)
G Length of Standard Wood Bunk	2.92m (9.6')	4.88m (16')	4.88m (16')	4.88m (16')
Optional Length 1	3.35m (11.5')	n/a	5.64m (18.5')	5.64m (18.5')
Optional Length 2	4.88m (16')	n/a	n/a	n/a

Structures

- Large engine side covers
- Heavy-duty engine and radiator house
- Purpose-built blade with wear resistant front cutting edge
- Optional brush sweeps
- Heavy frame articulation joints
- Full 40° articulation
- Heavy duty oscillation bearing and frame lock cylinder
- Adjustable log bunks with floating cam stakes

Loader Features

- Rear mounted loader with durable rack and pinion swing system
- Wrapped hoses
- Full load high reach boom
- 250° rotation
- European style butt-bypass grapple with high strength steel dampener

FORWARDER GENERAL SPECIFICATIONS

	2344, 4-Wheel	2346, 6-Wheel	2546, 6-Wheel	2548, 8-Wheel
Axle Front	Funk 1200	Funk 1200	Funk 1200	NAF Bogie
Axle Rear	Funk 1200	NAF Bogie	NAF Bogie (HD)	NAF Bogie (HD)
Front Axle Bogie lift				Optional
Engine	CAT C4.4 ACERT	CAT C4.4 ACERT	CAT C6.6 ACERT	CAT C6.6 ACERT
Standard Engine kw	93	93	129	129
Standard Engine hp	125	125	173	173
Fuel	178 L (47 gal)	178 L (47 gal)	178 L (47 gal)	178 L (47 gal)
Standard Tire Front	23.1 x 26	23.1 x 26	28 L x 26	700/50 x 26.5
Standard Tire Rear	23.1 x 26	600/55 x 26.5	700/50 x 26.5	700/50 x 26.5
Optional Tire Front	28 L x 26	28 L x 26	30.5 x 32	800/50 x 26.5
Optional Tire Rear	28 L x 26	700/50 x 26.5	800/50 x 26.5	800/50 x 26.5
Transmission	Electric Power Shift	Electric Power Shift	Electric Power Shift	Electric Power Shift
Gears	4/4	4/4	4/4	4/4
Maximum Forward Speed	23.33 km/h (14.5 mph)	23.33 km/h (14.5 mph)	23.33 km/h (14.5 mph)	23.33 km/h (14.5 mph)
Variable displacement load sensing piston pump	PVG 75 cc	PVG 75 cc	PVG 100 cc	PVG 100 cc
Flow @ 2200 rpm	188 l/m (49.7 gpm)	188 l/m (49.7 gpm)	250 l/m (66 gpm)	250 l/m (66 gpm)
Reservoir Capacity	121 L (32 gal)	121 L (32 gal)	121 L (32 gal)	121 L (32 gal)
Loader Reach — With 2-Piece Boom 5639 mm (18 ft, 6 in)	Standard	N/A	N/A	N/A
Loader With Telescopic Boom — 6.93 m (22 ft, 9 in) Reach	Optional	Standard	Standard	Standard
8.53 m (28 Sq ft) Clam Bunk	N/A	N/A	Optional	Optional
Bogie Tracks	N/A	Optional	Optional	Optional
Standard Operating Weight	12,247 kg (27,000 lbs)	14,062 kg (31,000 lbs)	16,330 kg (36,000 lbs)	17,237 kg (38,000 lbs)
Load Capacity	7,258 kg (16,000 lbs)	10,866 kg (24,000 lbs)	13,608 kg (30,000 lbs)	14,525 kg (32,000 lbs)
Optional Load Capacity	8,165 kg (18,000 lbs)			
Load Capacity with Clam Bunk Attachment			11,793 kg (26,000 lbs)	11,793 kg (26,000 lbs)



www.prenticeforestry.com

Caterpillar Forest Products
 535 Mack Todd Road
 Zebulon, NC 27597
 919-269-7421

We reserve the right to change specifications and to improve our products without notice or obligation.

Form No. PRFWD-0307 · Printed in U.S.A.