



Supplier Packaging & Shipping Manual

Electro Motive Diesel
9301 West 55th Street
La Grange, Illinois, U.S.A. 60525

Hodgkins Parts Distribution Center
6600 River Road
Hodgkins, Illinois, U.S.A. 60525

Progress Rail Services
3500 South Cowan Road
Muncie, IN, U.S.A 47302

REVISED January 1, 2013

This document is prepared by Electro Motive Diesel to guide suppliers to properly package material used in our facilities. These requirements are applicable for shipments to Electro-Motive Diesel, Hodgkins Parts Distribution Center, and EMCanada Co.

Supplier conformance to these Packaging Standards is mandatory. It is the responsibility of the supplier to deliver material properly packaged, free of corrosion, free of damage, and with the proper receiving documentation in accordance with these packaging requirements. Failure to comply will result in the issuance of a Quality Notice (QN).

Notice of Liability and Caution:

The information contained within this manual is distributed on an “as is” basis, without warranty. While every precaution has been taken in the preparation of this manual, the authors shall not have any liability to any person or entity with respect to any liability, loss, or damage caused or alleged to be caused directly or indirectly by the instructions contained in this manual. It remains the responsibility of the users of this manual to establish appropriate safety and health practices and to determine the applicability of all government agencies and the regulatory requirements in conjunction with its use.

These standards are subject to periodic review and users are cautioned to obtain the latest version.

This document supersedes all previous editions:

Prepared by:

EMD Packaging
EMD Purchasing
EMD Environmental
EMD Ergonomics
EMD Supplier Quality
EMD Chemicals

INDEX

DOCUMENT INFORMATION	PG. 2
INDEX	PG. 3
ENVIRONMENTAL & ERGONOMIC PACKAGING	PG. 4-8
• PALLET BOXES	
• CORNER SUPPORTS	
• FOAM DUNNAGE	
• BANDING	
• PLASTIC RECYCLE IDENTIFICATION	
• ERGONOMICS	
• HAZARDOUS MATERIALS	
CORROSION PREVENTION & PART CLEANLINESS	PG. 9-11
• VCI PROTECTION	
• APPROVED VCI SUPPLIERS	
• EMD CHEMICAL MANAGER INFORMATION	
WOOD PACKAGING MATERIALS	PG. 12-18
• WOOD PALLETS	
• WOOD CRATES	
• WOOD DUNNAGE	
• APPROVED WOOD PACKAGING MATERIAL SUPPLIERS	
HODGKINS PARTS DISTRIBUTION CENTER PACKAGING	PG. 19-23
• HEAT TREATED WOOD PACKAGING MATERIALS	
• EXPORT HT NAIL-LESS KIT BOX	
• CORRUGATED BOXES	
• APPROVED CORRUGATED SUPPLIER CONTACT INFORMATION	
ATTACHING REQUIRED DOCUMENTS TO SHIPMENTS	PG. 24-28
• SHIPTO ADDRESS LABEL	
• MIXED LOAD LABEL	
• PART IDENTIFICATION LABEL	
• PACKING LIST	
• BAR CODES	
BAR CODE REQUIREMENTS	PG. 24-28
• SHIPTO ADDRESS LABEL	

ENVIRONMENT & ERGONOMIC PACKAGING

PALLET BOXES:

Wire bound crates are not allowed; replace them with a wood pallet box, MH-6020 as shown on page 19. If weight and size permit replace wire bound packaging materials with a bulk corrugated kit box (self contained), constructed with a “breakaway” feature to allow easy removal of the corrugated from the HT wood pallet. The breakaway feature requires stapling the corrugated tray to the HT pallet. This allows the corrugated to separate easily from the HT pallet.



ENVIRONMENT & ERGONOMIC PACKAGING



ENVIRONMENT & ERGONOMIC PACKAGING

CORNER SUPPORTS:

All corrugated cartons are recycled after use. Any contaminant such as wood that is fastened to the corrugated to add structural strength will be removed before recycling. **Therefore, wood is not to be nailed, glued or stapled to the corners, walls or to the carton top or bottom.**

- To add strength to a self contained corrugated bulk kit box (photo pg. 5) use 2 x 4 board lumber as shown. The use of “angle board” with a white clay coating and non-water-soluble adhesive as a corner support **is not allowed. When angle board is glued to corrugated, it cannot be recycled.**

FOAM DUNNAGE:

The following **CANNOT** be used:

Foam glued to corrugated, or any other dissimilar materials bonded together.

Expanded Polystyrene (EPS) - SPI Code #6 foam in sheets or loose such as foam peanuts are not allowed as a filler in the packaging.

- The use of a wax coating applied to the corrugated **is not permitted.**
- VCI coated corrugated cartons **are allowed.**
- Foam-in-place packaging **is not allowed.**

The use of foam dunnage to protect parts from abrasion or part-to-part contact is not allowed. Currently, EMD has no economical solutions for recycling foam, which causes material to be used as landfill. Replace the foam with the suggested alternatives shown below:

Alternative to foam: Replace it with other recyclable materials such as die-cut corrugated build-up inserts or molded Kraft Paper pulp. Other substitutes for the foam are bubble wrap and wadding paper.

STRAPPING:

EMD is working to minimize the use of steel banding in our facilities due to the risk of cuts from handling steel material. Polyester banding should be used to minimize both the risk of injury and the cost of the banding. Suppliers are not to use steel banding when shipping parts to EMD facilities unless approved of by EMD Packaging Engineer. EMD suggests using polyester banding with the following minimum requirements: 5/8” width, 0.035” thickness, 1400 lbs. break strength. Only a plastic banding tensioning tool should be used to tension and secure plastic banding.



ENVIRONMENT & ERGONOMIC PACKAGING

Stretch wrap poly is the acceptable method of securing cartons to a pallet. Use clear film as the absence of color maximizes recycling potential. An LDPE (low-density Polyethylene) is the most commonly used and is the highest in performance allowing maximum hold of a carton to a pallet. Wrap the palletized unit with only the required amount of film. Your stretch film supplier can assist you with the proper use of the equipment and material. **PVC film is not to be used.**

PLASTIC RECYCLE IDENTIFICATION:

To facilitate the recycling of plastic packaging products its identity must be known. Electro Motive Diesel requires the marking of the SPI (Society of Plastic Industry) code on all plastic products. All vacuum-formed and injection-molded plastic packaging material must be identified by the SPI code as per the chart below.

Plastic packaging components such as plugs, caps, and covers are to be marked with SPI code. All manufactured plastic component parts should be identified with the proper SAE Code to facilitate recycling.

Mold the SPI code into the plastic part.

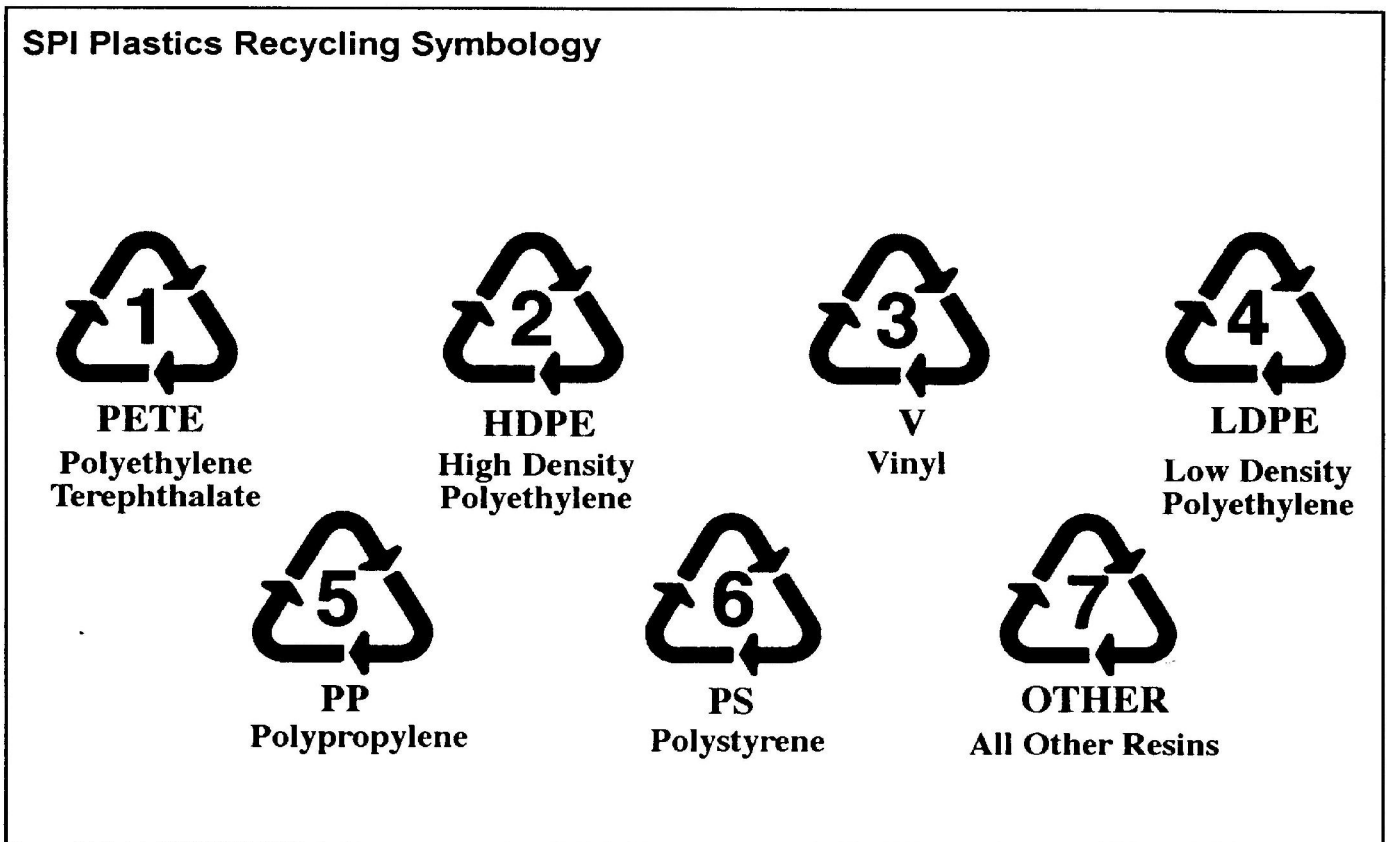

ENVIRONMENT & ERGONOMIC PACKAGING

WASTEFUL, EXCESSIVE, OR NON-RECYCLABLE MATERIAL:

Packaging will serve many needs; parts protection, transportation effectiveness, synchronous manufacturing, ergonomic and environmental concerns to name a few. Excessive, “just-in-case” packaging is undesirable and costly for both the supplier and Electro Motive Diesel. The supplier is expected to identify and eliminate wasteful packaging practices on an ongoing basis. With reduction or elimination as the first priority, the hierarchy of waste elimination is:

REDUCE REUSE RECYCLE

ERGONOMICS:

OVERVIEW:

Poor packaging and handling practices result in work related injuries. These injuries will increase cost and will have a negative effect on productivity, safety and quality. In order to reduce the costs associated with these losses, it is imperative that we improve the manual material handling of our packages. The following standards have been adopted from research guidelines and principles designed to reduce the risk factors associated with work related injuries.

PACKAGING DIMENSIONS:

The guidelines below are based on manual material handling techniques which allow parts in boxes to be carried close to the body and will not require excessive bending or squatting. In addition the box height is important; it must be a reasonable height for a person to reach into the over-pack box to pick material out of it. Therefore, the height on large wood boxes with pallet attached must not exceed 32 inches. If the part requires a taller box then use a style as suggested on pages 4 and 5.

HAND HELD BOXES:

The maximum acceptable gross weight of any hand held box is 39 lbs. The weight of the package should be written on the box, shown in letters sized 1.50“, or the weight of the package can be printed on a standard label of generic size and design.

HAZARDOUS MATERIALS:

Hazardous materials must be packaged in accordance with the appropriate Department of Transportation (DOT) Regulations using Performance Oriented Packaging or other packaging as stated in the regulation. A supplier of a hazardous material must submit a Material Safety Data Sheet to EMD Purchasing before the material will be allowed for use at EMD. The EMD Hazardous Materials Control Committee must review and approve all MSDS submissions. This is required for all hazardous materials shipped to EMD LaGrange, Hodgkins Distribution or EMCANADA facilities. The sending in of hazardous materials samples or bringing in these unauthorized hazardous materials without prior approval is forbidden.

CORROSION PREVENTION & PART CLEANLINESS

It is the supplier's responsibility to protect their manufactured steel parts (ferrous non-ferrous metals) from corrosion discoloration through use of a suitable multi metal VCI paper, VCI poly film or a rust preventative coating.

VCI paper is porous; it allows for easy volatilization and will achieve protection for the piece part rapidly. VCI film is slow in volatilization and works best for long-term protection when used in conjunction with VCI paper or VCI protective coating.

Rust preventative (RP) oils seal the metal surface from oxygen and moisture and protect the surface from dust, dirt and gases. Oil is a temporary rust preventative coating and will not give long-term protection to the part.

VCI Oils contain vapors that protect the exposed metal surfaces it gives longer term protection for the part and it seals the metal from the outside environment

All VCI products and rust preventative coatings afford the best protection for steel parts when the material is free of dust, soap residue dirt and contaminants. It is important to wear gloves when handling clean ferrous and non ferrous parts prior to packaging. The names of approved supplies and the contact information are contained on page 11.

The supplier is responsible to adequately protect the part from all forms of damage. Contact the writer or Hodgkins Packaging Coordinator 708-387-6451 for further information.

VCI USEFUL TIPS:

Those parts susceptible to corrosion cannot be in direct contact with corrugated box, wood box, skid or other packaging products; there **must** be a **VCI poly or VCI paper** barrier between the product and the packaging.

Wear gloves when physically handling the material.

- When directed to do so by EMD, parts may require additional long term preservation packaging. Parts may be subject to large variances in temperature and humidity and as such they may require either a foil vapor barrier bag, a heavy gauge 8ml. plain or VCI poly bag.
- Obtain information about the vapor barrier material and its' use from a VCI supplier or the writer.
- For an extremely large irregular shaped part packaged in VCI poly or foil vapor barrier packaging, vacuum out the excessive air inside the packaging to enable the VCI to work quickly within its' protective packaging.
- Parts must never be placed into the packaging wet from a wash operation or liquid VCI application.
- The part must be clean, free from soap residue and other dirt contaminants.
- Inquire to your VCI supplier or the writer the proper use of VCI coating products.
- **It's the responsibility of the supplier to disclose to the VCI provider the manufacturing process so that the VCI provider can recommend the correct VCI corrosion protection product to use for the application.**

CORROSION PREVENTION & PART CLEANLINESS

WAREHOUSE RELOCATION IN LAGRANGE

EMD relocated all manufacturing warehouses to a separate building away from the manufacturing assembly lines. Parts are placed in carset kit racks then transported between buildings to the assembly lines. This movement, and the change in storage conditions make the parts vulnerable to corrosion.

- As a general rule, all steel parts require corrosion protection.
- Large steel parts delivered on pallets must have a corrosion protective VCI poly or a coating. Bulk, open top boxes (example is on page 18) must be lined with a suitable VCI bag that is sealed once the parts are loaded.
- Large steel parts that are partially machined must have a corrosion protective coating applied. These parts must then be placed into a large, completely enclosed box with a top cap lid (examples on pages 4, 5 and 21). This box must be lined with a suitable VCI bag that is sealed once the parts are loaded.
- Unmachined cast and forged parts should be placed in open top boxes (example is on page 18) that are lined with a suitable VCI bag that is sealed once the parts are loaded. Eventually the parts will be painted and they need protection from corrosion to allow the paint to adhere.
- Please use the contact names provided as a resource for information about the selection of these corrosion prevention products (see page 11)
- Adherence to these practices will prevent corrosion to metal parts and avoid the issuance of a QN.

CORROSION PREVENTION & PART CLEANLINESS

EMD SUPPLIER OF VCI

ARMOR Protective Packaging®

951 Jones St.

Howell, MI 48843 USA

Ph. (800) 365-1117 (517) 546-1117

Fax. (517) 546-6434

Email: info@armorvci.com

Websites: www.armorvci.com & www.metalrescue.com

Contact Information

Regional Sales Manager Jerry Golebiewski- ph. 630-291-7410 jgolebiewski@armorvci.com

Customer Service Julie Eastwood -ph. 517-546-1117 x 223 jeastwood@armorvci.com

Customer Service Nicole Payne – ph. 517-546-1117 x 225 npayne@armorvci.com

Technical Services Wes Measel – ph. 517-546-1117 x227 wmeasel@armorvci.com

International Sales Mgr Fernando Longinotti- ph. 289-244-9100 flonginotti@armorvci.com

ARMOR Protective Packaging® provides the industry's cleanest, easiest, safest and most effective corrosion management systems for metal products. Armor's full line of vapor corrosion inhibitor (VCI) packaging products, desiccants and its rust removal and prevention liquids are designed to protect metals before, during and after transport or storage. Armor's industry reputation as a trusted business partner has been built by serving its customers and preserving their investments for more than a quarter-century.

Product offering

ARMOR WRAP® VCI Papers – A full line of corrosion products and inhibiting papers for rust tarnish and overall corrosion prevention.

ARMOR POLY® VCI Films – Full line of corrosion inhibiting bags, sheeting, tubing, shrink film, elastic bonnets, zipper closures, wickets, automatic bags, wide web export sheeting and other specialty films.

ARMOR SHIELD® VCI Products – Full line of innovative corrosion inhibiting packaging including emitters, corrugated, foam, bubble wrap, banding film, stretch film, chips and more.

ARMOR SHIELD® Desiccants – Full line of desiccant drying agents in convenient forms for effectively reducing the humidity inside of a closed container.

DRY COAT™ RP – Water-based rust preventative spray/dip that dries to the touch.

METAL RESCUE™ – Rust Remover Bath that is safe, clean and easy to use. Removes rust without harming metal or other materials (plastics, paint and rubber) and it is environmentally safe and safe to use.

Solution Recovery Services (SRS) is the EMD In-House, Chemical Manager that provides EMD us with cleaning and cutting fluids, and recommends preservative products that are compatible with EMD's manufacturing processes. SRS also assists EMD in the selection of those products that are environmentally safe (ECO friendly) and keep parts free of corrosion during, and after the manufacturing process.

SRS ON SITE MANAGER

BRETT IRVIN

708 387 3768

734 476 6991

birvin@teamusi.com

WOOD PACKAGING MATERIALS

Managing the disposal or recycling of wood pallets continues to be a challenge for EMD. EMD reuses or recycles as many as possible. Please see Pages 13-17 for pallet sizes and specifications. Where economically feasible, EMD encourages the use of returnable pallets constructed of steel or recycled plastics.

IMPORT SHIPMENTS: material shipped to EMD London or Hodgkins Distribution in wood containers or packaging must be ISPM certified, or the wood packaging material must be fumigated in accordance with ISPM Standards. It is not necessary to use ISPM wood for shipments into LaGrange.

PALLETS

Suppliers are required to ship material to Hodgkins on ISPM, HT Certified pallets as this material is likely to be shipped to export customers. **It is not required to use ISPM certified pallets for inbound shipments to Dock H.**

The standard acceptable pallet sizes for material stored in location racks are 48" length, 40" width" and 48" length 45" width. The only pallet variation allowed is 36" **for width**. A short dimension for the length will only be allowed if pre-approved by the writer. Acceptance of this small pallet length will be dependent upon storage rack location system within EMD.

Many loads arrive at EMD with the banding loose and end deck boards broken, loose or missing. This is caused by smaller boxes being placed on the larger pallet. This can be corrected by placing the banding through the top deck boards in a location closest to packaging. Banding this way prevents the steel from cutting through or breaking the end and top deck boards.

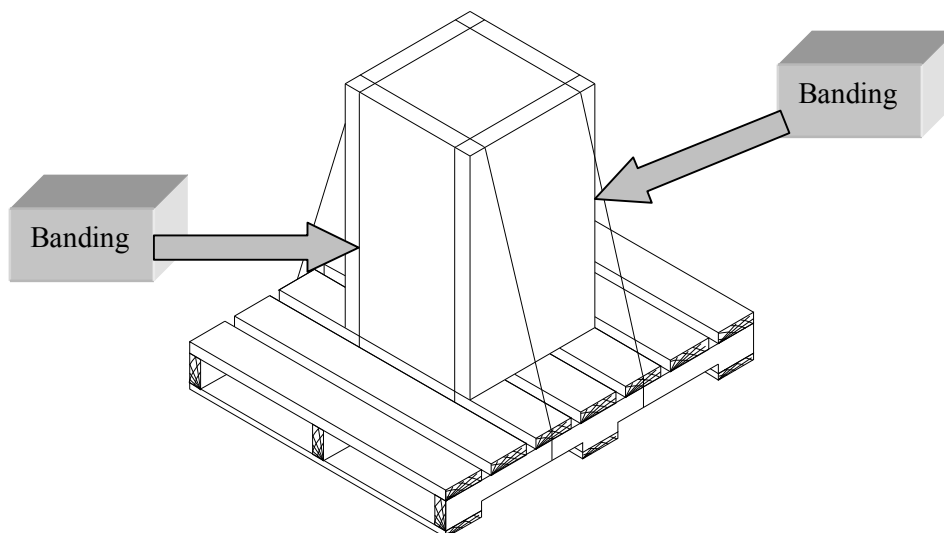

There are numerous options to consider when designing a pallet: the various species of woods available plus the part size and weight. A pallet supplier can assist in determining the correct pallet through the use of a "computer pallet program" that automatically calculates the inputs (part size and weight) and it designs the correct pallet.

WOOD PACKAGING MATERIALS

MH-6001 STANDARD VENDOR PALLET

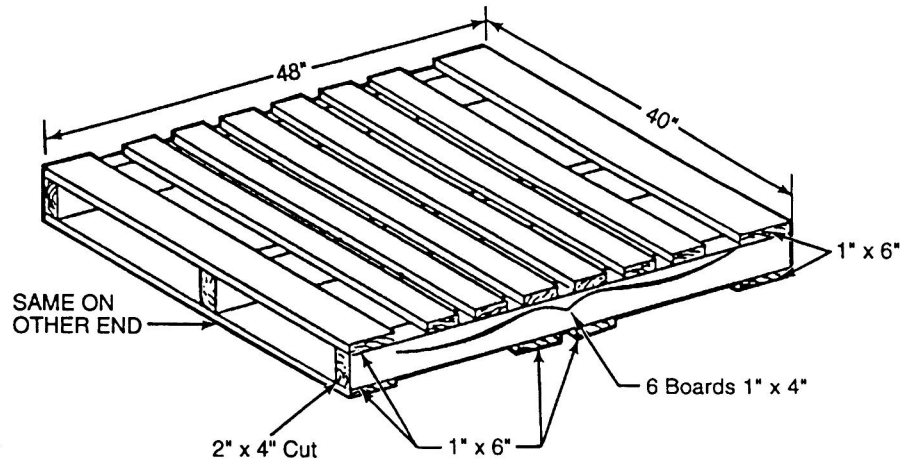

PALLET SPECIFICATIONS:

- 1 All lumber must be a species of hardwood (Ex. Oak, Ash, Hickory and Maple)
- 2 Load limit, 3000 lbs
- 3 Length and width $\pm 1/8$ " is allowed
- 4 Assemble pallet with hardened screw drive nails, (3-1/2" x .120", and screw head diameter. 1/4" \pm 1/64").
- 5 All 6" boards have (3) nails per joint; 4" boards have (2) nails per joint.

NOTE: Material weight must be evenly distributed on the pallet. The deck boards must not be used to support the weight of heavy material, that weight must be transferred onto the runner boards. Because of size and weight of material, a pallet may require an additional runner board in the design. Therefore the R709488 pallet must be used for loads needing the additional center support. If any pallet exceeds 60" in length, 4-way entry must be part of the design. Other choices, the R709488 can be used in place of the MH6001.

WOOD PACKAGING MATERIALS

R709488 PALLET

4 stringer pallet design maximum load 5,000 lbs capacity single stacked, transporting heavy loads casting, heads liners and pistons. Stacked 4 high the safe load capacity per pallet is 3400 lbs.

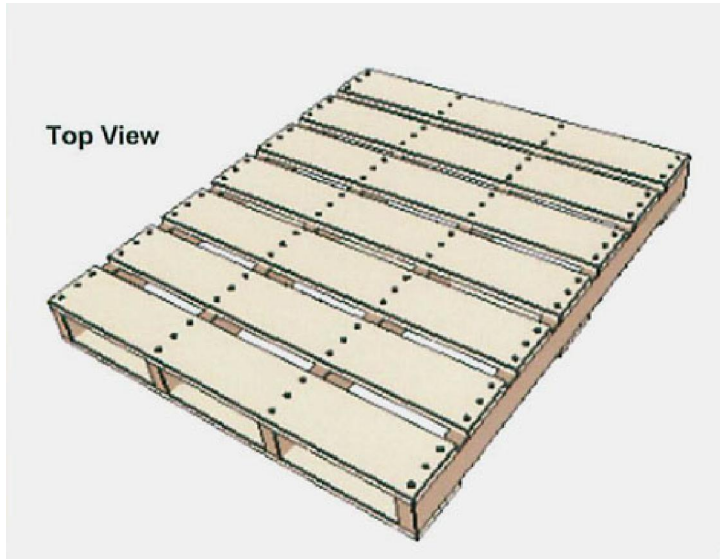

Pallet ID: R709488 - Approved Vendor Pallet - ISPM 15 Compliant Classification: 48.00 x 40.00, Stringer-Class, Double-Face Non-Reversible, 2-Way, Multiple-Use, New Manufacture Pallet Treatments: ISPM-15 Compliance: Heat Treatment (HT)											
<p>Side View 48.00</p>	<p>Top View 40.00 48.00</p>	<p>Bottom View 40.00 48.00</p>									
<p>End View 40.00 4.88</p>											
Components		Materials									
Top Deck: Style: Deckboard Type: New Lumber <table border="1"> <thead> <tr> <th>Number</th> <th>Thickness</th> <th>Width</th> <th>Length</th> </tr> </thead> <tbody> <tr> <td>7</td> <td>0.688</td> <td>5.500</td> <td>40.00</td> </tr> </tbody> </table> Volume: 7.4 bd ft		Number	Thickness	Width	Length	7	0.688	5.500	40.00	Fasteners: Fastener ID: 2 x .099 SS Fastener Type: Helically Threaded Nail Fastener Length: 2.00 Thread Length: 1.25 Thread Diameter: 0.115 Wire Diameter: 0.099 Head Diameter: 0.250 Helixes: 5.4 Flutes: 4 Thread Angle: 69 MIBANT Angle: 36 FWI: 63 FSI: 55 Total Number: 120	
Number	Thickness	Width	Length								
7	0.688	5.500	40.00								
Bottom Deck: Style: Deckboard Type: New Lumber <table border="1"> <thead> <tr> <th>Number</th> <th>Thickness</th> <th>Width</th> <th>Length</th> </tr> </thead> <tbody> <tr> <td>3</td> <td>0.688</td> <td>5.500</td> <td>40.00</td> </tr> </tbody> </table> Volume: 3.2 bd ft		Number	Thickness	Width	Length	3	0.688	5.500	40.00	New Lumber: Lumber ID: KD HT Softwood Species Class: SPF Grade: Utility &BTR Moisture Content (at manufacture and assembly): Kiln Dry - 19% Total New Lumber Volume: 17.5 bd ft	
Number	Thickness	Width	Length								
3	0.688	5.500	40.00								
Stringers: Type: New Lumber <table border="1"> <thead> <tr> <th>Number</th> <th>Width</th> <th>Height</th> <th>Length</th> </tr> </thead> <tbody> <tr> <td>4</td> <td>1.500</td> <td>3.500</td> <td>48.00</td> </tr> </tbody> </table> Volume: 7.0 bd ft		Number	Width	Height	Length	4	1.500	3.500	48.00		
Number	Width	Height	Length								
4	1.500	3.500	48.00								

R709488 pallet design by: OX BOX (pds. license 554) for EMDiesels

WOOD PACKAGING MATERIALS

MH 200 PALLET

MH-200 HEAVY DUTY PALLET

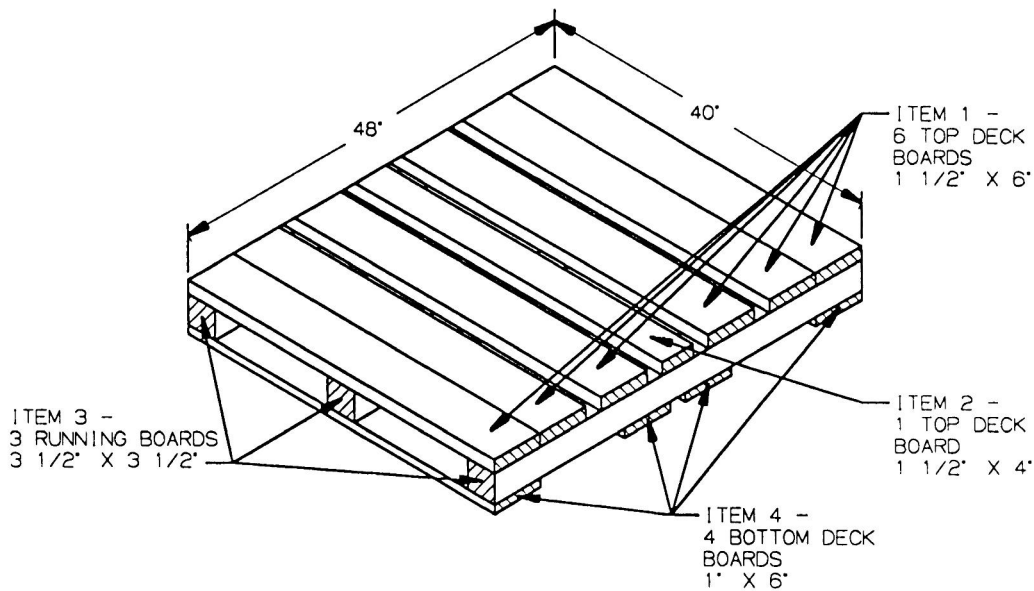

PALLET SPECIFICATIONS:

- 1 All lumber must be a species of hardwood (Ex. Oak, Ash, Hickory and Maple)
- 2 Load limit, 6000 lbs
- 3 Length and width $\pm 1/8$ " is allowed
- 4 Assemble pallet with hardened screw drive nails, (3-1/2" x .120", and screw head dia. 1/4" $\pm 1/64$ ").
- 5 All 6" boards have (3) nails per joint; 4" boards have (2) nails per joint.

NOTE: Material weight must be evenly distributed on the pallet. The deck boards must not be used to support the weight of heavy material, that weight must be transferred onto the runner boards. Because of size and weight of material, it may require an additional runner board in the design of the pallet. If the pallet exceeds 60" in length, 4-way entry must be part of the design.

WOOD PACKAGING MATERIALS

WINGED PALLET

R709350

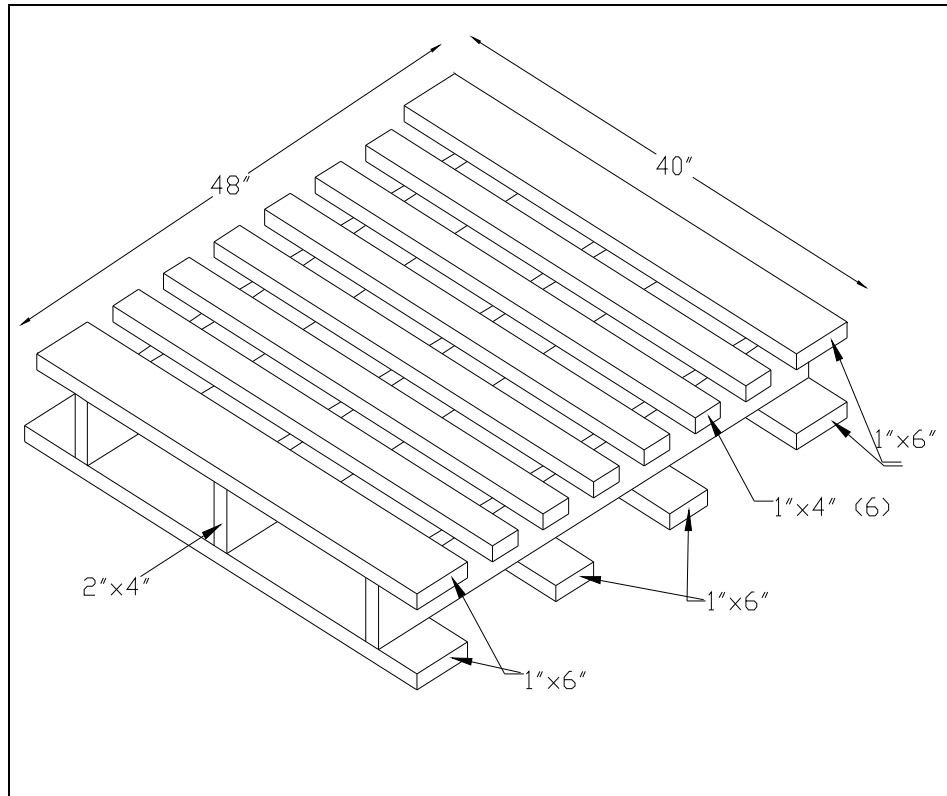

PALLET SPECIFICATIONS:

- 1 Top deck end boards are 1"x6". The other six (6) top deck boards are 1"x4".
- 2 All bottom deck boards are 1"x6".
- 3 Runners are a minimum 1 ½" x 3 ½" (may be cut rough).
- 4 Lumber must be a species of hardwood (Ex. Hickory, Oak, Maple, and Ash).
- 5 Must be assembled using screw nails.
- 6 Load limit is 3000 lbs.

NOTES: Winged pallets are designed to accommodate heavy loads (castings, forgings, etc.).

WOOD PACKAGING MATERIALS

PALLETS AND WOOD BULK SHIPPING PALLET BOX UNIVERSAL PALLET FOR EMCANADA COMPANY R794020

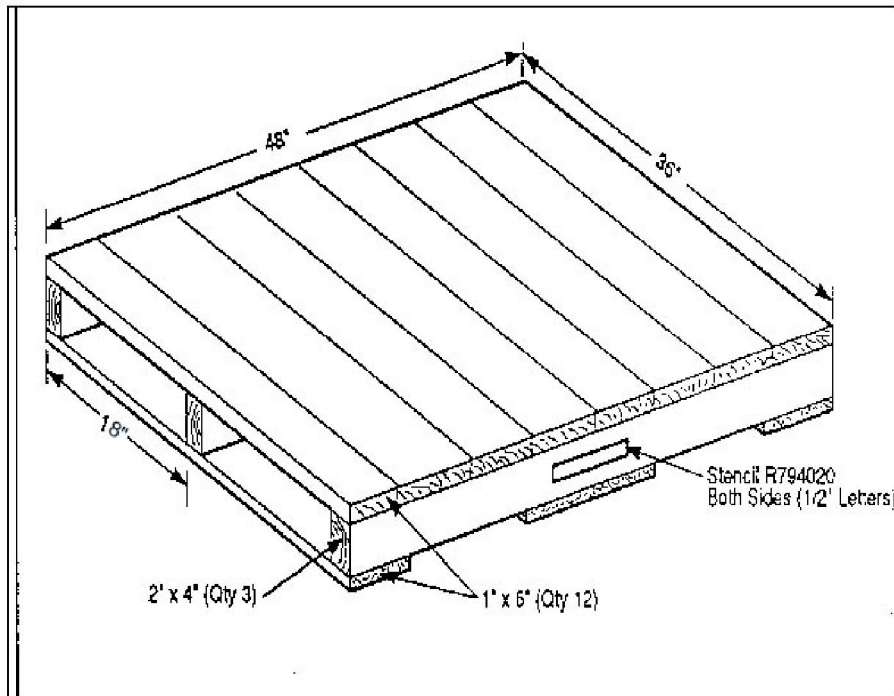

SPECIFICATIONS:

1. Solid top decks (8 pieces) and end boards are 1" x 6", (rough cut, random width preferred).
2. All bottom deck boards (4 pieces) are 1" x 6" (rough cut, random width preferred).
3. Runners are 2" x 4" (nominal).
4. **All lumber must be a species of hardwood (Ex. Oak, Ash, Hickory, and Maple).**
5. Must be assembled using 3" spiral nails.
6. R794020 must be stenciled in 1/2" high characters centered over each outside runner.

When a non-standard pallet must be used due to the size and characteristics of the material the supplier must utilize a pallet with construction similar to R794020. If the pallet exceeds 60" in length, 4-way entry must be part of the design. Material weight must be evenly distributed on the pallet. Contact the EMCanada Co. Material Handling/Packaging Representative at 519-452-5206 if more information is required. The Material Handling/Packaging Representative has Preferred Pallet Suppliers who will extend EMCanada Co. pricing onto their suppliers. Supplier contacts are available upon request. **Contact your EMCanada Co. or EMDiesel Representative at 519-452-5206.**

MARKING REUSABLE SHIPPING CONTAINERS; WOOD, PLASTIC, STEEL AND PALLETS FOR EMCanada Co.

All returnable containers must be clearly marked "**Returnable**". Prior authorization for their use must be obtained from the Material Handling Department at EMCanada Co. Shipment of returns back to suppliers can be arranged through the Shipping Department at 519-452-5206.

WOOD PACKAGING MATERIALS

BULK SHIPPING BOX

When a wooden pallet has been specified or is required for reasons of strength or durability it must be 36" wide x 48" long. See attached drawing R794020. Specialty designed pallets may be available for parts which do not fit on this size of pallet. Contact the EMCanada Co. Material

WOOD BOX PALLET MH-6020 FOR CASTINGS, FORGINGS, BULK HEAVY MATERIAL

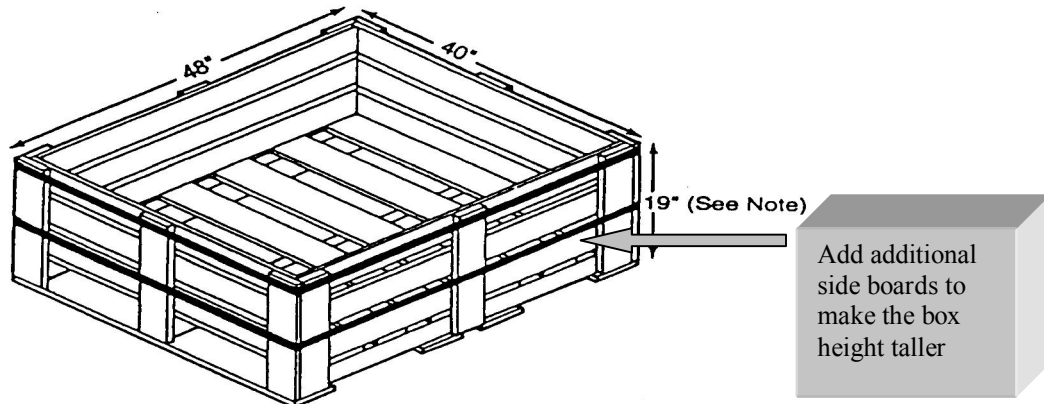

PALLET SPECIFICATIONS:

- 1 Top deck end boards are 1" x 6" (min. 5/8" x 5-1/2"). The six (6) other top deck boards are 1" x 4" (min. 1/2" x 3-1/2").
- 2 All bottom deck boards are 1-1/8" x 6" (min. 1-1/8" x 5-1/2") and must extend a maximum of 3/4" beyond runners at sides and ends.
- 3 Runners are a minimum 1-1/2" x 3-1/2" (may be rough cut).
- 4 All lumber must be a species of hardwood (Ex. Oak, Hickory, Maple, and Ash)
- 5 Must be assembled with screw nails.

BOX SPECIFICATIONS:

- 1 All boards for sides, ends and cleats are 1" x 4" (minimum 5/8" x 3-1/2").
- 2 Three (3) horizontal boards are required on sides and ends. Vertical boards must rest on extended bottom deck boards.
- 3 All lumber must be a species of hardwood (Ex. Oak, Ash, Hickory and Maple)
- 4 Vertical boards must be nailed to runners.
- 5 Tack nail at top of box while banding.
- 6 Strap horizontally at top and middle with two (2) 3/4" x .023 minimum flat steel strapping.

NOTE: Standard height of pallet box from the floor is 19". This size may be increased to height up to 25". When the bulk boxes are constructed according to the design as shown they can stack two (2) high. A higher side 25" will require additional horizontal side boards.

HODGKINS PARTS DISTRIBUTION CENTER PACKAGING

BASIC GUIDELINES

EMD is a global supplier of locomotive parts that ship from our Hodgkins, Distribution Facility. Many factors are taken into consideration when EMD has the distribution facility pick, pack and ship parts to customers; the ship to location, domestic or export, packaging durability, export HT Certification of wood, corrosion protection, to name a few.

For Hodgkins to be efficient, the parts received from suppliers must be packaged, ready for warehouse storage, and available for customer shipment immediately upon demand. Today some supplier packaging materials must be replaced by Hodgkins when they do not meet a customer requirement or the Hodgkins written packaging instruction. Hodgkins has a data base that has a specific packaging instruction for a part. Since EMD is requesting the suppliers to package the material, those Hodgkins packaging instructions will be shown on the Purchase Order given to the supplier. That being said, EMD has made arrangements for suppliers to purchase such packaging materials from OX BOX, on their on-line store. Details of this program are on the website: EMDiesels Packaging Requirements Instruction Guide, http://www.emdiesels.com/emdweb/emd_index.jsp.

No supplier logo (symbols, names or addresses) is to appear on the packaging, i.e., cartons, boxes, over-pack, labels, etc.

EMD is not expecting to be involved in the detail of individual parts packaging other than the directives in this packaging requirement's booklet. If a problem or question arises, call the Hodgkins Packaging Coordinator for assistance 708-387- 6451 or the writer.

SERVICE PARTS SHIPMENTS

Parts packaged, stored in the warehouse at Hodgkins will ship to both export and domestic customers and the final destination is not known until the parts order is taken and processed. Therefore, careful and cost competitive packaging must be selected. That being said, all parts susceptible to corrosion or damage must receive packaging that will sustain protection for two years of storage.

Questions regarding packaging, the quantity per pack, or whether the packaging should be wood, corrugate or a combination of the two that is to be determined by the Hodgkins Packaging Coordinator (708) 387-6451. In addition look to the EMD Purchase Order for additional packaging instructions and EMD customer requirements.

PARTS ASSEMBLY COMPONENT KITS (More than one box make up a kit)

Multiple part numbers all packed in separate boxes when joined together become a kit, (example 3 boxes marked as 1 of 3, 2 of 3 and 3 of 3), mark the boxes accordingly. Suppliers when packaging kits place the parts in a bulk corrugate kit box similar to that as shown on pages 4 and 5. When the kit arrives at Hodgkins it will be stored in the warehouse and shipped to the customer in that bulk box as a complete parts assembly kit.

HODGKINS PARTS DISTRIBUTION CENTER PACKAGING

EXPORT PALLETS OR PLYWOOD AND WOOD BOXES

A plank wood (un-surfaced) rough-sawn board lumber box poses a problem in the factories as the lumber easily breaks, and it is not accepted. Boxes constructed from OSB, Oriented Strand Board are not allowed as a packaging material. During handling and transport the blade of a fork truck can easily puncture the board and when this occurs the box strength is greatly reduced.

HEAT TREAT REQUIREMENT OF WOOD PRODUCTS, ISPM #15 RULES



Effective September 15, 2005, all lumber exported from the United States and imported into the United States are required to have been heat-treated HT Certified **to be compliant to the ISPM-15 Rule**. This includes wood boxes made from board lumber; pallets and interior wood used for blocking and bracing (dunnage on the inside of wood or corrugated boxes). Plywood boxes are excluded from this regulation however, the lumber attached (cleating or blocking and bracing lumber) attached to plywood is subject to this regulation. The stamp shown above must appear on the wood box on two opposing sides. The absence of this marking will cause the customs department within the country to quarantine the freight until proper documentation is provided by the shipper. The documentation the shipper must provide is proof that the wood materials used to construct the box are properly treated in accordance with the ISPM Standards. Noncompliance to this regulation and all requirements could result in confiscation of the shipment by a US or Foreign Government Customs Department.

EMD PACKAGING REQUIREMENT FOR EXPORT CUSTOMERS MUST BE IN COMPLIANCE TO THE ISPM, HT Standard. Shipments into Hodgkins, the wood boxes, pallets, blocking and bracing materials used in a box must be made from HT Treated wood. In addition to these requirements bark is not allowed it must be removed with a rasp tool. Visit the websites below to obtain further information regarding the ISPM #15 rules. An additional resource for information regarding ISPM 15 Rulings is OXBOX, EMD supplier of wood boxes (see page 22 for their contact information).

For details regarding ISPM #15 Rules see:

<http://www.nwpc.ca/ExportTreatment/ExportTreatmentProg.htm> Refer to the following Canadian Food Inspection Agency website for more details: www.inspection.gc.ca/english/plaveg/protect/dir/d-98-08e.shtml

HODGKINS PARTS DISTRIBUTION CENTER PACKAGING

EXPORT HT NAIL-LESS KIT BOX

For export shipments the box should be sized to maximize the cube of a sea container 44" width ODS.



Industrial Packaging, by OXBOX - Compliant with EMD Packaging Requirements

Boxes

- wood (*HT - export compliant*)
 - o bulk plywood boxes
 - o bulk nail-less kit boxes sized to cube sea containers 44" width OD
- corrugated
 - o heavy-duty construction
 - o stock boxes
 - over 900 sizes in stock
 - available on-line
- wood & corrugated, bulk kit boxes **domestic use only**
 - o self-contained design box (see pg .4) custom designed and stock sizes are available
- packaging supplies
 - o tape, labels, stretch film, edge protectors, strapping, poly bags
 - available on-line

HODGKINS PARTS DISTRIBUTION CENTER PACKAGING

Pallets

- wood (*HT - export compliant and EMD approved*)
- plastic structural foam, injection molded, Hi-Density Polyethylene
- corrugate plastic returnable packaging
- computer assisted pallet designs

Packaging Materials and Services

- VCI poly and paper
- Packaging and multiple parts kit preparation services
- return packaging systems and designs

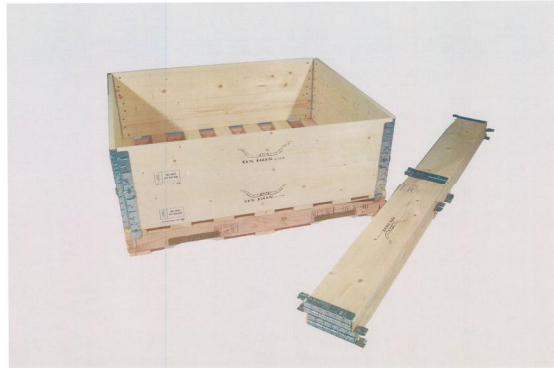

OX BOX Contact information:

Stan Joray

Vice President

Email: sjoray@oxbox.com

OX BOX

1555 Wrightwood Court

Addison, IL 60101

(630) 620-1BOX

(630) 889-1BOX - Fax

www.oxbox.com

The supplier to EMD of corrugate packaging is:

Batavia Container

400 Paramount Pkwy

Batavia IL 60510

Randy Wians

Account Development Manager

P- 630-879-2100

F- 630-879-2276

E- randyw@bcibox.com

Website address – www.Bataviacontainer.com

As information to the EMD suppliers, Batavia Container provides corrugate boxes to EMD. Suppliers receive EMD pricing for boxes they wish to purchase. The factors which might affect the pricing the supplier will receive are the quantity of boxes ordered and shipping costs must be considered.

HODGKINS PARTS DISTRIBUTION CENTER PACKAGING

Batavia Container will supply:

- Standard cartons through custom die cuts, and printing on boxes up to 4 colors.
- A custom and standard design concept is available.
- Engineers are available on site to assist with packaging designs and will create and guide you towards the best possible solution.
- Custom Kit box designs are available.
- Batavia Container will design cost effective packaging, we specialize in analyzing a best possible solution for a package.
- Below are some of Batavia's capabilities to support your needs.

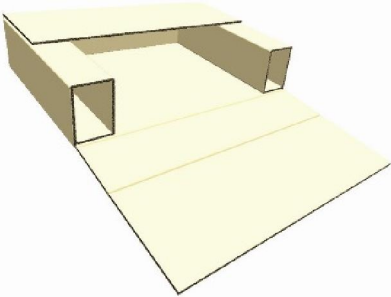

Partitions.....
various sized
compartments

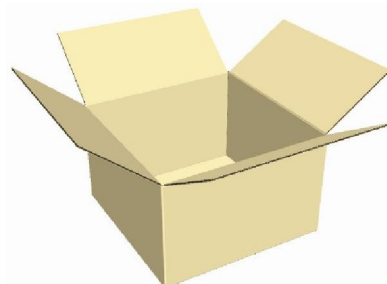
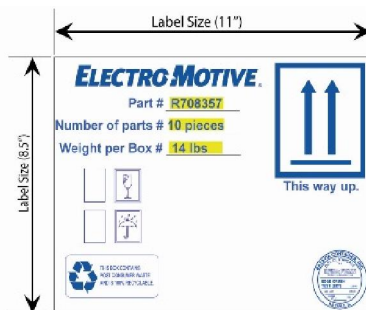
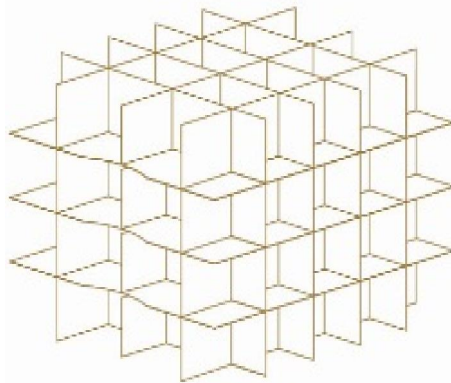

Printing can
be added to
the corrugate
box

ATTACHING REQUIRED DOCUMENTS TO SHIPMENTS

The labels and packing list are essential to Electro-Motive Diesel. receiving and accounts payable departments for verification of receipt and to pay a supplier invoice. To facilitate the receiving of material and invoicing processes EMD requires suppliers to bar code certain inbound receiving documents. We recognize that providing bar codes on packing list and labels can be challenging. The bar codes EMD suppliers are providing on packaging, labels and other documents cannot be read with EMD scanners.

Therefore, EMD is providing information for suppliers to purchase labeling software with formatted templates to generate an EMD packing list, part number label with bar codes and templates to print an Address and Mixed Load Labels. **If you have software that prints a packing list and part number label with bar codes continue to use it. Print the forms scan the bar codes with a reader to verify they can be read. If you have other software and print capabilities to produce the other labels, address and mixed load there is not a need to purchase ADSI software. There are examples of these requirements on pages 26-28). The ADSI bar code software was tested by EMD; a packing list was generated and with an ADSI recommended scanner the bar codes were read.**

For pricing and description of the software, scanner, printer and label stock go to: website www.emdiels.com, Packaging Requirements and to order bar code software contact:

Steve Hickman
Advanced Distribution Solutions Inc.
shickman@adsionline.com
1- 630 - 881 - 2070

SUMMARY: Definitions and explanations of the labeling and bar code requirements:

Packing List must be placed in a packing list envelope for each shipment and affixed on the outside of a carton, container that is marked "1 of ___" the shipment. All item/part number information on the packing slip must be legible and available on one side of a single sheet of the packing list form. A single part number packaged in multiple cartons, display the Packing List on the top carton also, place a label on each carton that states the total number of cartons in the shipment, "1 of ___".

1. We prefer to have the single one (1) part number material listed on one (1) packing slip with a total quantity for that shipment, not multiple packing slips.
2. Attached to each shipment must document titled packing list and assigned a unique identifier a number, and it must be clearly marked on your invoice in the upper right hand corner.
3. **Part Identification Label:** It's required on the outside of each individual packaged carton or box. It identifies the parts and quantities contained inside the individual boxes. At no time is it permitted to stack material on a pallet or in a bulk box in such a manner that part number identification and packing list information is not visible.
4. **Address Label:** Must be visible and can be affixed to the outside of a box, containment device or to stretch film if it is used contain smaller boxes on a pallet.
5. **Mix Load Label:** Placed on a pallet or to the outside of a box with many smaller boxes having different part number stacked within. Shipments of mixed part numbers routed to different plants must be separated according to their EMD Purchase Order Number. This avoids having to re-palletize the material before it can be sent to the receiving warehouse.
6. The BOL must specify the NUMBER and TYPE of containers in the shipment (box, pallet, reel, drum, etc.)

ATTACHING REQUIRED DOCUMENTS TO SHIPMENTS

7. The Bill of Lading will list all the packing lists that are part of the shipment.
8. An invoice is to reference only one packing list. See EMDiesels Website for further information.

Suppliers are required to apply Bar Code Symbol 128 Labels, if you generate a label in code 39 our scanners are set to read that code. Note: Code 128 will print a higher quality bar code which makes it easier to scan and read.

Packing List data requirements:

- The unit of measure **MUST be** the same as the purchase order unit of measure
- Vendor name and address
- *Vendor Code
- *Purchase Order Number
- *Purchase Order Line Item
- *The EMD customer part number, and where applicable the related serial number as specified by the Purchase Order
- Unit of measure
- *Identify the unique packing slip number in the upper right hand corner of the document.
- *BOL Number
- Mode of shipment to EMD, including carrier and type of vehicle, as specified on the EMD purchase order
- EMD Warehouse designation and delivery address as specified on the purchase order
- *The quantity shipped is to be shown. **DO NOT SHOW** the quantity ordered or the quantity on back on this packing slip.
- The description of the material as specified on the EMD Purchase Order.
- EMD Customer Order, modification, and specification information as specified on the EMD Purchase Order.

***DENOTES BAR CODE REQUIRED**

ATTACHING REQUIRED DOCUMENTS TO SHIPMENTS

Your Company Name

Your Company Name
Your company address
City, state, zip

Sold to:

Electro Motive Diesel
9301 W 55th Street
La Grange, IL 60525

Ship to:

Electro Motive Diesel
9301 W 55th Street
Dock H
La Grange, IL 60525

Packing Slip

Vendor Code



301063

1 Of 1

Vendor Packing Slip#



17263

BOL/SID



55955

Customer PO#



4500231231

Date Shipped: 04/06/10		F.O.B: Bridgeview		Shipped Via: Landstar	
Customer PO Line #	Weight	Customer Part #	Part Description	Qty Shipped	UOM
 01	1374	 8266137	Bolt 1-1/4 12 special	 400	ea

IMPORTANT: On the Packing List in the field "Sold To:" place in this position the delivery address as shown on the EMD Purchase order.

ATTACHING REQUIRED DOCUMENTS TO SHIPMENTS

Address Label INSTRUCTIONS

Address Label 4" X 3" minimum size an address label is required on each Handling Unit.

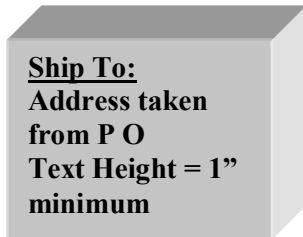

NOTE: IF YOU ARE CURRENTLY USING A 4"x6" LABEL THIS IS ACCEPTABLE SYSTEM

Mixed Load Label INSTRUCTIONS

Mixed Load Label 4" X 3" – This is used when more than one part is on a (HU) Handling Unit.



Part Identification Label Instructions

The supplier is to provide a part number identification label, of a generic design and it must have the following information: Part number, (bar code) Quantity, manufacturing Date Code (do not bar code) if it is not known the shipping or packaging date will be accepted. **Note: if the part is date sensitive then it is mandatory the expiration date be applied to the label!** Parts shipped to manufacturing loose (usually bulk pieces) on a skid or inside a bulk open top crate must have the part number stamped on each part with non-corrosive ink or attach a wire manila tag.

Shipments to APL Hodgkins, steel piece parts placed loose on a pallet or in a bulk box, not packaged, place the part number on each piece part use a wire tag or ink stamp the part number on each piece.

ATTACHING REQUIRED DOCUMENTS TO SHIPMENTS

Part Identification Label 4" X 3"

Date Code	Quantity
Part number	
	
1 of _ _ _	

A carton, which is a complete container in itself, whether palletized or loose it, must have a Part Number Identification Label.

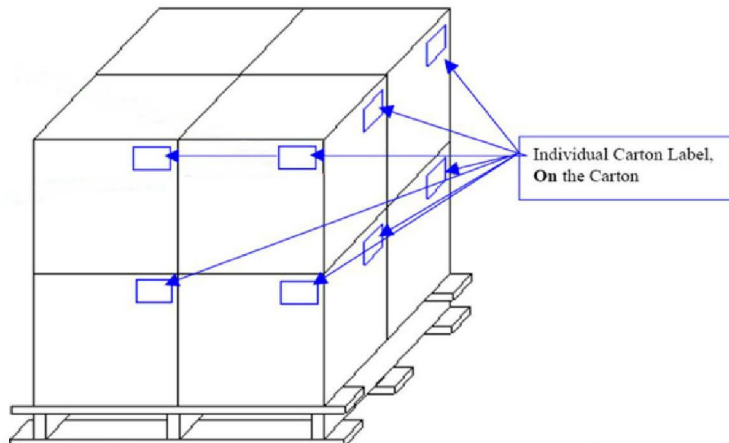

EMD BASIC PACKAGING REQUIREMENTS PACKING LIST INSTRUCTIONS