



**Shown with Altec®
LRV60-E70**



Shown with Altec[®]
LRV60-E70 Lift



**All Terrain
Carrier**

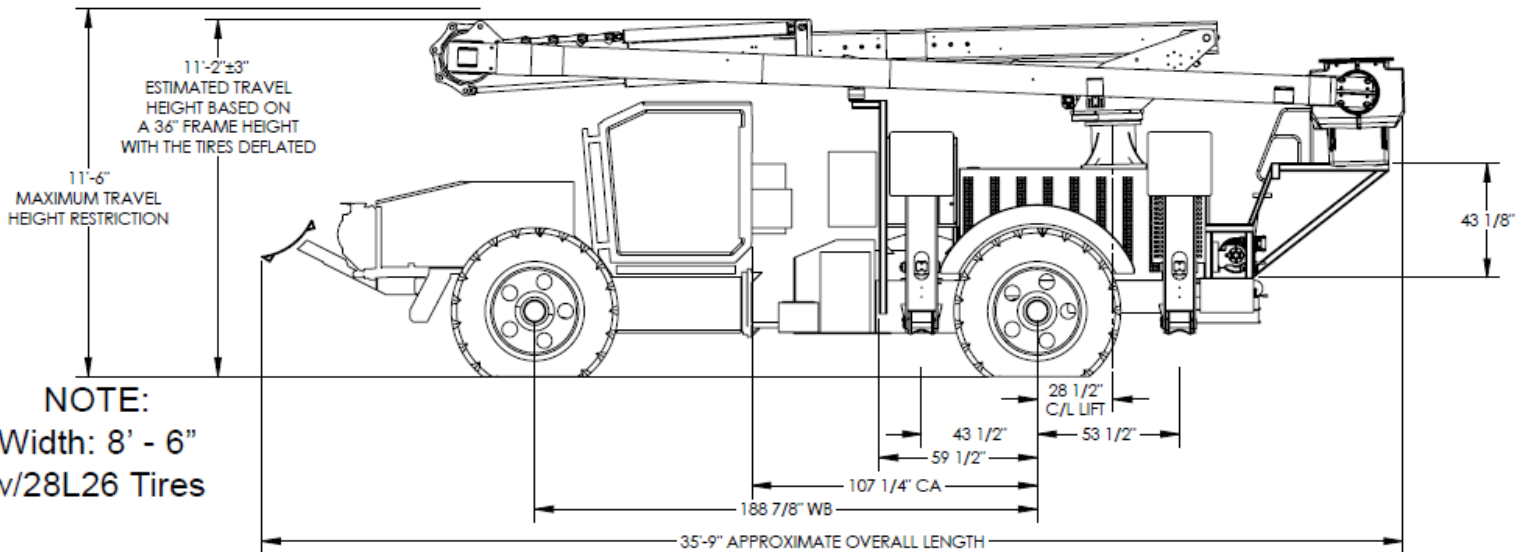

Description: The ATC7 is an all terrain, rubber-tired vehicle capable of supporting various aftermarket attachments. The machine is specifically designed for the vegetation management industry. Provides easy access to remote areas of utility, highway, and railroad right-of-ways.

Frame: Consists of welded construction front and rear main frames with structural tubing, solid members and fabricated side members. Front and rear frames are connected by an articulating joint allowing 15 degrees of up or down oscillation and 45 degrees right or left power steering action. Equipped with four hydraulically controlled outriggers for stability.

Weight: Approximately 39,000 lbs. with standard 28L26 tires and 70 ft. elevator aerial lift installed.

Engine: Equipped with liquid-cooled 4.4 liter Caterpillar[®] diesel engine rated for 127 hp @ 2200 rpm. Open engine compartment for maximum accessibility with light weight composite doors.

Propel System: Hydrostatic 4-wheel drive with propel motor driving through a heavy-duty 2-speed powershift transmission.

Transmission and Axles: 2-speed shift-on-the-go transmission connected by heavy-duty Dana-Spicer 1550 drive shafts to both axles. Heavy-duty axles with wet disc service brakes. Axles are equipped with hydraulic lockable differentials.

Wheels, Tires and Brakes: Tires: 28L-26 logger type tire standard. Wheels are adjustable to change track width. Service brakes are wet disc inboard hydraulically applied and "built-in" the axles. Parking brakes are fail-safe spring-applied/hydraulic-released wet disc drive-line mounted. Parking brakes will automatically apply and stop machine if engine stops.

Hydraulic System: Engine driven pump drive. Hydrostatic propel system consists of closed loop pump driving a hydraulic propel motor mounted on transmission. Charge loop filtration. Hydraulic reservoir mounted outside engine compartment with cleanout port and shutoff valve. Equipped with electric emergency pump.

Electrical System: 12 volt dc negative ground with engine driven alternator and two 12-volt batteries w/950 cold cranking amps each.

Cab: Angled front roof profile equipped with 1 1/4" thick tinted Lexan roof viewing window. Fully enclosed cab with heater and air conditioner. Tilt steering wheel uses flow amplification to produce a variable oil flow to steering cylinders in relation to steering wheel speed. Fully adjustable seat with suspension, seat belts and lumbar support. Front windshield wiper, dome light, Lexan windows, window guards, electric horn, 5 lb. ABC fire extinguisher and full engine instrumentation are standard.

Travel Speed: Low range: 4.4 mph, high range: 16.6 mph w/ 28L26 tires.

Capacities: Fuel: 80 gallons. Hydraulic: 30 gallons.

Ground Clearance: With 28L26 tires: 19".

Optional Equipment: AM/FM radio w/CD player. Two 20 lb. fire extinguishers.

Other Options Available: Compatible with most popular brands of bucket lifts. Capable of supporting various other aftermarket attachments.