

Brushcutter 32-10

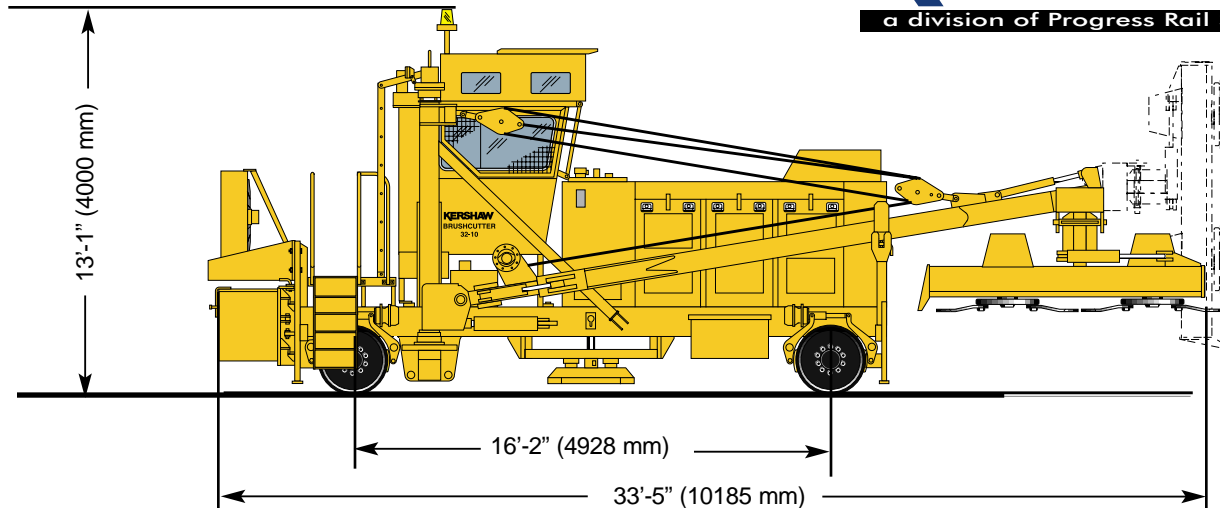

a division of Progress Rail Services



Description: The Kershaw 32 clears brush and overhanging branches from railroad right-of-way. It is capable of cutting up to 30 ft. (9144 mm) from the track center, and leaves behind a biodegradable mulch.

Frame: Welded construction of side frame member and formed plate cross-members.

Weight: 62,000 lb. (28123.2 kg)

Engine: Caterpillar C7 Tier III rated for 300 hp @ 2200 rpm.

Propel System: Closed loop variable displacement axial piston pump driving a fixed displacement axial piston motor. Maximum travel speed is 35 mph with full time four wheel drive.

Transmission and Axle: Hydrostatic transmission drives a 4 speed gear box. Front and rear automotive type axles with automatic positive locking differentials are driven through cardan shafts with slip joints.

Wheel and Brakes: 28 inch cast steel wheels are bolted to axle hubs. 4-wheel clasp brakes are axle mounted. Service brakes are air applied and spring released. Parking brakes are spring applied and air released. Suspension system utilizes coil springs.

Air System: Air compressor, engine oil lubricated, air cooled; 13 cu. ft free air volume @ 2200 rpm; system pressure 100 psi; 613 cu. in. air tank. Air is supplied to service brakes through a pressure reducing valve with pressure gauge. Parking brake is set by means of a electrically activated air dump valve. System is also equipped with dual tone air horns and a safety relief valve.

Hydraulic System: The engine drives a triple pump drive through a clutch. Two triple pumps power the cutter motors and the cutter head control circuits.

Electrical System: 24 volts dc negative ground; 95 amp alternator; color coded and numbered wiring.

Cab: The cab accommodates two operators (one for each cutterhead). Adequate height is provided for standing at entry door and rear section. Each operator has a set of foot pedals for controlling direction. The cab is equipped with heater, air conditioner, and a pressurization unit. Cab side walls are double wall construction (1/4" A514 over 11 ga.) with Lexan® marguard windows.

Capacities: Fuel tank: 110 gallons. Hydraulic tank: 100 gallons.

Cutterhead: Booms can rotate a 10 ft. wide double disk cutterhead outboard up to 30 ft. from rail centerline and 45° up/40° down from horizontal. Single boom operation is made possible by shifting a counterweight hydraulically to opposite side of the live cutterhead.

Turntable System: The Brushcutter has a turntable and can be turned manually.

Controls: Two 5-section valves (one for each operator) control the functions of the respective cutterheads. Boom in/out, up/down, and cutterhead pitch, tilt, and rotate are controlled by these valves. Travel direction is controlled by hydraulic foot pedals at each operator position.

Because of Kershaw's continuous desire to improve products, specifications and design are subject to change at any time and without notice and without incurring any obligation to incorporate these changes in previous models. Illustrations and photographs may include optional equipment and may not include standard equipment. (August 2008)

Printed In U.S.A.

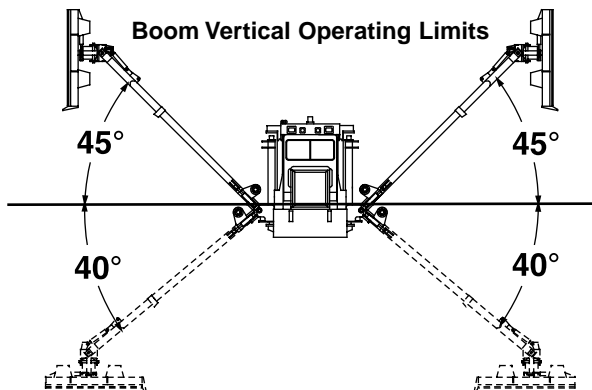

Post Office Box 244100
Montgomery, Alabama 36124-4100 USA
Telephone (334) 387-9100
Fax (334) 387-9375