



Vegetation Control Equipment



Kershaw SkyTrim 75 G2

The SkyTrim is a rough terrain, rubber-tired vehicle with telescoping boom and saw-type cutter head designed to trim trees.





Kershaw SkyTrim 75 G2

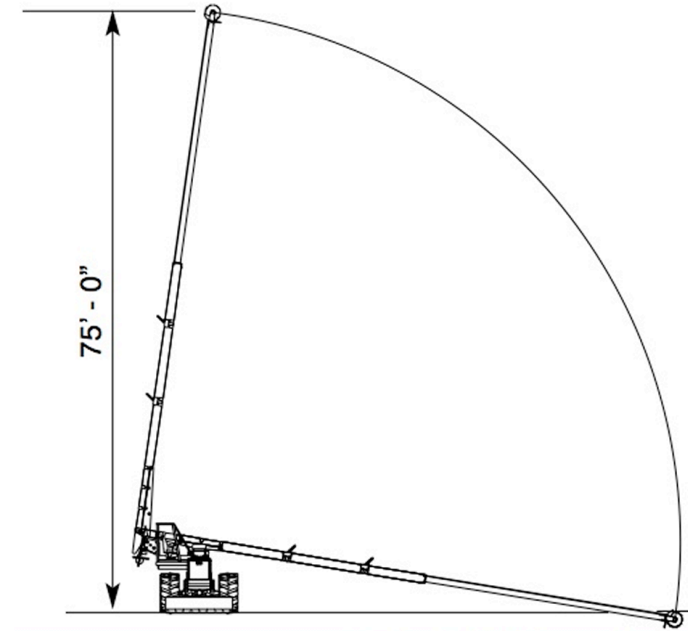
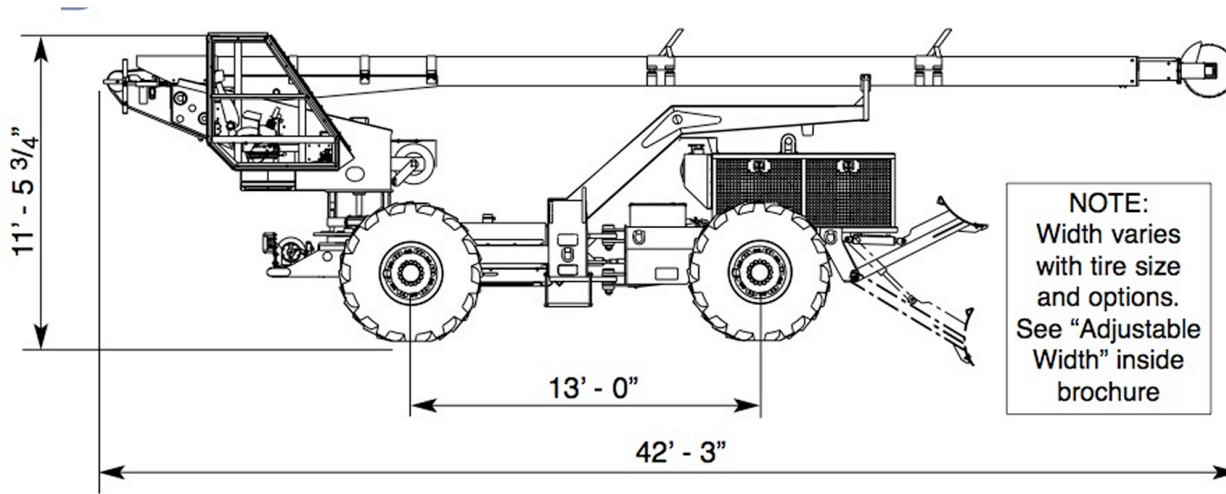



SkyTrim 75 G2

Frame: Welded construction front and rear main frames. High strength alloy steel superstructure.

Weight: Approximately 24,300 lbs with standard tires.

Engine: Equipped with liquid-cooled 4.4 liter Caterpillar® diesel engine rated for 127 hp @ 2200 rpm. Open engine compartment for maximum accessibility with light weight composite doors.

Propel System: Hydrostatic 4-wheel drive with propel motor driving through a heavy-duty 2-speed powershift transmission to limited-slip and lock-on-demand axles.

Inserting Force: 14,000lbs(62kN).

Propel System: Hydrostatic drive. One two-speed hydraulic motor coupled to front and rear axle with direct chain drive. Travel speed is 30 mph.

Transmission and Axles: 2-speed shift-on-the-go transmission connected by heavy-duty drive shafts to both axles. Heavy-duty Caterpillar® axles with inboard wet disc service brakes. Rear axle is rigid mounted lock-on-demand, front axle designed to oscillate.

Wheels and Brakes: Tires: 28L-26 logger type tire standard. Wheels are adjustable to change track width. Service brakes are wet disc inboard hydraulically applied and "built-in" the axles. Parking brakes are fail-safe spring-applied/hydraulic-released wet disc drive-line mounted. Parking brakes will automatically apply and stop machine if engine stops.

Hydraulic System: Engine driven pump drive. Hydrostatic propel system consists of closed loop pump driving a hydraulic propel motor mounted on transmission. Charge loop filtration. Hydraulic reservoir mounted outside engine compartment with cleanout port and shutoff valve. Equipped with electric emergency pump. Upper structure tilt system and boom up/down system equipped with lock valves

Electrical System: 12 volt dc negative ground with engine driven alternator and two 12-volt batteries w/950 cold cranking amps each. Equipped with safety electric strobe light.

Capacities: Fuel: 60 gal. Hydraulic: 30 gal.

Cab: Equipped with 1 1/4" tinted Lexgard® top, engine instruments, and ergonomic seat. Equipped with light touch hydraulic pilot pressure joystick for extend-lift-swing-tilt boom controls. Heavy duty swing bearing with worm gear drive for maximum tooth engagement. Floor is fully enclosed. Back is fully enclosed with safety tinted Lexgard®. Access door is full length tinted Lexgard® with positive latch. Optional fully enclosed cab with heater and air conditioner available.

Boom: Telescoping composite construction with 75 ft. reach from ground. Telescoping boom driven with #50 chain. Each unit is electrically insulated and tested to ANSI A92.2-2001 Category C standards to 100 kv for maximum operator safety. Equipped with single 24 inch diameter carbide-tipped saw turning @ 2800 rpm.

Optional Equipment: Front mounted winch. Optional tire sizes. Air conditioner & heater with enclosed cab. Other options available upon request.