



## Kershaw Scorpion RS64 DL Ramp

The Kershaw RS64 Ramp is a “roll-up” loading ramp that can be used to load all work equipment that is normally transported on a flat car. It can load both rail bound and rubber tired machines. Rubber tired and most rail bound machines can climb the 7% slope with ease. A winch is provided for disabled machines or machines that do not have sufficient traction to climb the ramp slope. One man can extend or retract the ramp in less than 5 minutes using a remote pushbutton control.

- Deploy and retract sequence is all fully automatic with stage timing controlled by sequencing valves and cams. The operator simply holds down the deploy or retract button through the complete sequence.
- When retracted and stored for travel, the Scorpion fits within “C” plate clearance dimensions. Optional bridging bar systems are available to allow movement from one flat car to another. The coupler is retained to allow transportation in train formation.
- A self-contained diesel power plant drives hydraulic pumps to provide power for the hydraulic cylinders and winch. The engine is housed in a lockable enclosure with controls and instrumentation.
- A hydraulic tank and diesel fuel tank share a lockable enclosure with easy access for maintenance and service. Fluid levels are easily checked by observing the sight glass tubes.
- The ramp can be installed on a customer provided flat car or can be provided complete with car. The deck and frame must be of welded construction.
- Most machines have no problem climbing the 7% slope to load on the Scorpion. A hydraulic winch is provided for machines that cannot load under their own power.





## RS64DL Ramp

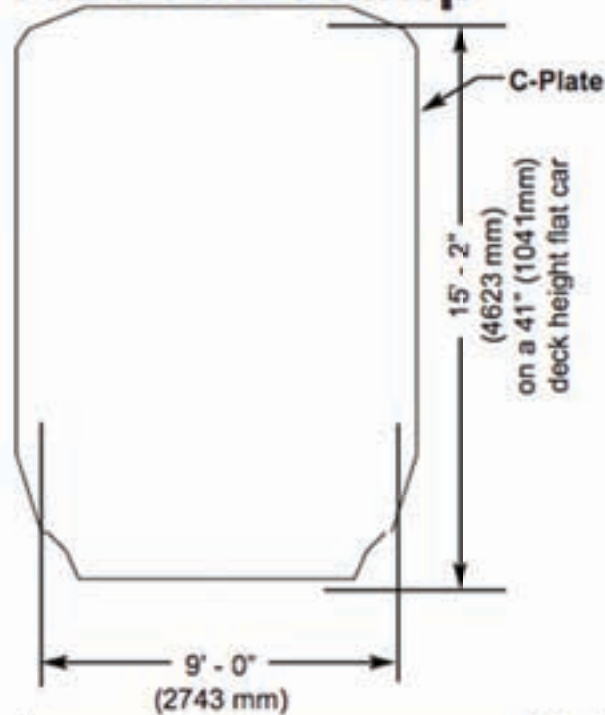

Ramp In Retracted & Stored Position

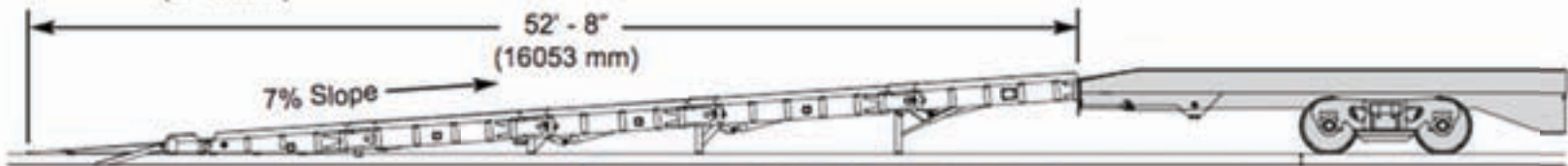
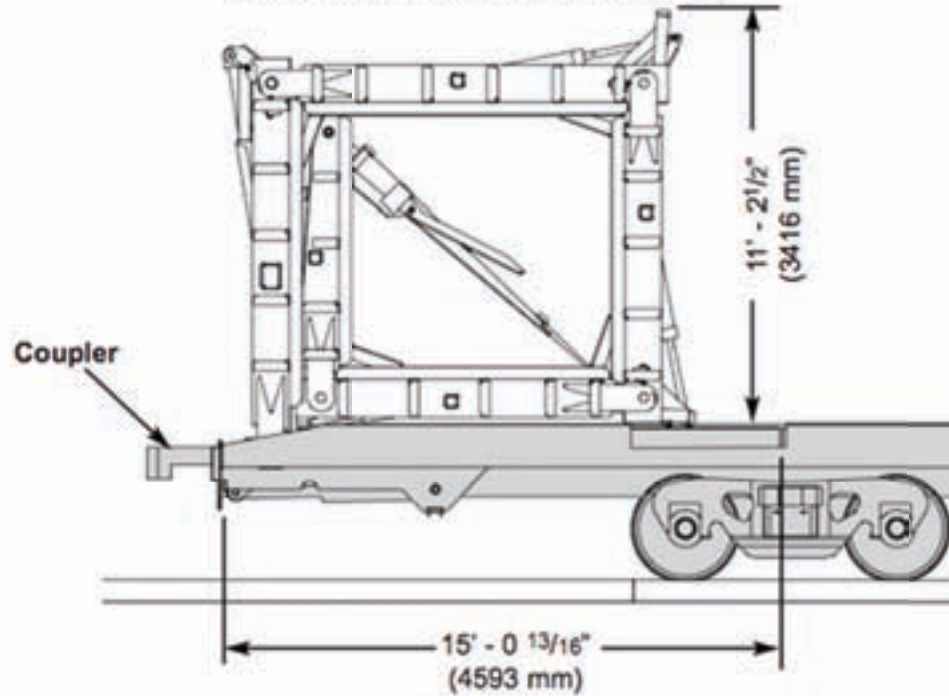



## Kershaw Scorpion RS64 DL Ramp

**Weight:** The ramp adds 13,000 pounds (5900 kg) to the weight of a flat car.

**Construction:** Welded from tubular steel. Tread bearing areas are made from wear resistant steel.

**Engine:** Air cooled diesel Deutz F2L2011 30 hp (22.4 KW) @3000rpm.

**Winch:** Equipped with 5/8 (16 mm) inch wire rope. Retrieval speeds: 12 (3.66 m) feet per minute/high speed; 7 (2.13 m) feet per minute/low speed. Maximum tension: 20,000 pounds (9072 kg).

**Hydraulic System:** A gear pump is driven directly by the engine providing hydraulic power to the ramp control circuit. Filters protect the ramp circuits from contamination. A pendant with pushbuttons is used to energize a solenoid directional valve that cycles the ramp.

**Electrical System:** 12 volt dc negative ground. Maintained by an engine driven 40 amp alternator. Equipped with a special coiled plate 56 amp hour battery. Color coded and numbered wiring.

**Loading Capacity:** The ramp can support 40,000 pounds (18144 kg) per axle on rail bound machines and 30,000 pounds (13608 kg) per axle on rubber tired machines.

**Capacities:** Fuel: 11.5 gal. (43.5 l), Hydraulic: 25 gal. (94.6 l).

**Options:** Adjustable wheel chocks, turnbuckle tie downs, bridging bar systems to allow movement of machines from one flat car to another.

Because of Kershaw's continuous desire to improve products, specifications and design are subject to change at any time and without notice and without incurring any obligation to incorporate these changes in previous models. Illustrations and photographs may include optional equipment and may not include standard equipment.