

General Specifications

Gas Turbine

- Mercury[™]50 Recuperated Gas Turbine
- Industrial, Single-Shaft
- 10-Stage Axial Compressor
 - Variable Inlet Guide Vanes and Stators
 - Compression Ratio: 9.9:1
 - Inlet Airflow: 39.2 lb/sec (17.9 kg/sec)
 - Vertically Split Case
- Combustion Chamber, Annular Type
 - Ultra-Lean-Premix Combustion System
 - 8 Fuel Injectors
 - Single Torch Ignitor System
- Proximity Probe Vibration Transducers
- Turbine
 - 2-Stage, Reaction
 - Clockwise Rotation
- Bearings
 - 2 Radial: Viscous Damped Roller Bearings
 - 1 Thrust/Radial: Viscous Damped Split Inner Race Ball Bearing

Recuperator

- Primary Surface Type

Main Reduction Drive

- Epicyclic
 - 1500 or 1800 rpm (50 or 60 Hz)
 - Vibration Monitoring: Acceleration Transducer

Generator

- 4 Pole, 3 Phase, 6 Wire, Wye Connected, Synchronous with Permanent Magnet Exciter
- Available Construction Type:
 - Open Drip-Proof
- Sleeve Bearings
- Vibration Monitoring: Velocity Transducers
- Class F Temperature Rise
- Class B Temperature Rise*

- NEMA Class F Insulation with F Rise
- Continuous Duty Rating Voltages:
 - 3300, 6600, 11,000 (50Hz)
 - 4160, 6900, 12,470, 13,800V(60 Hz)

Package

- Mechanical Construction
 - Steel Base Frame with Drip Pans and Generator Alignment
 - 316L Stainless Steel Piping
- Start System
 - Direct Drive AC Motor with VFD Control
- Package Electrical Certification
 - NEC, CSA Class 1, Group D, Div 2
- Fuel System
 - Natural Gas
 - Landfill Gas*
 - Digester Gas*
- Integrated Lube Oil System
 - Main/Pre/Post Lube PumpBackupLube Pump
 - Air and Oil Cooler
 - Water/Oil Lube Oil Cooler*
 - Integral Lube Oil Tank
 - Lube Oil Tank Heater
 - Simplex Lube Oil Filter
 - Duplex Lube Oil Filters*
 - Oil Mist Eliminator
 - Vent Flame Trap
- Air Inlet and Exhaust Systems
 - Carbon Steel
 - Stainless Steel*
 - Barrier Type Filters
 - Self-Cleaning Filters
 - Inlet and Exhaust Silencers
 - Inlet Evaporative Cooler*
 - Inlet Chiller Coils*
- Enclosure
 - Complete Package
 - Fire Detection and CO2 Suppression System

- Turbine Compressor Cleaning Systems
 - On-Crank
 - Portable Cleaning Tank*
- Package Power
 - 120VDC Battery/Charger System*
- TurboTronic[®] 4 On-skid Gas Turbine Control System
 - Combination Gas Turbine and Control System
 - Standard Display with Discrete Event Log, Strip Chart, Historical Trend, Maintenance Screen
 - Vibration and Temperature Monitoring
 - English Display Text and Labels
 - Spanish, Portuguese, German, French or Simplified Chinese Display Text and Labels*
 - Auxiliary and Remote Display/Control Terminals*
 - Auto Synchronizing
 - KW Import Control
 - KVAR/Power Factor Control*
 - ControlNet Redundant Media, Ethernet, Data Highway Plus or Modbus RS232C/422/485 Supervisory Interface*
 - Heat Recovery Application Interface*
 - Multi-Unit Applications: Load Shed Control, Import/Export or kW/KVAR Control Panels*
 - InSight System[™] Equipment Health Management
 - Printer/Logger
- Documentation
 - Drawings
 - Quality Control Data Book
 - Test Reports
 - Operation and Maintenance Manuals
- Factory Testing of Turbine and Package
 - Non-Dynamic
 - Dynamic

Nominal Performance*

Output Power	4600 kWe
Heat Rate	9350 kJ/kWe-hr (8865 Btu/kWe-hr)
Exhaust Flow	63 700 kg/hr (140,400 lb/hr)
Exhaust Temperature	365°C (690°F)

*ASSUMPTIONS

Nominal rating – per ISO
At 15°C (59°F), sea level
No inlet/exhaust losses
Relative humidity 60%
Natural gas fuel with
LHV = 35 MJ/Nm³ (940 Btu/scf)
No accessory losses
Engine efficiency: 38.5%
(measured at generator terminals)

Application Performance

Steam (Unfired)	6.0 tonnes/hr (13,125 lb/hr)
Steam (Fired)	47.1 tonnes/hr (103,865 lb/hr)
Chilling (Absorp.)	5140 kW (1460 refrigeration tons)

Available Power

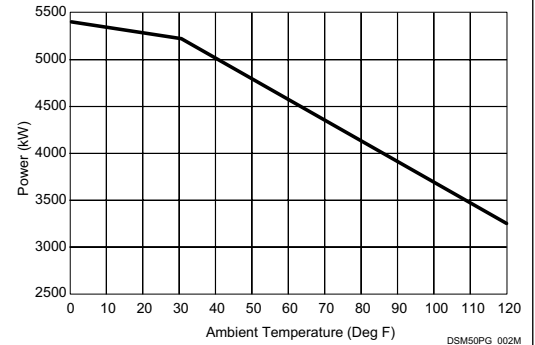

Heat Rate

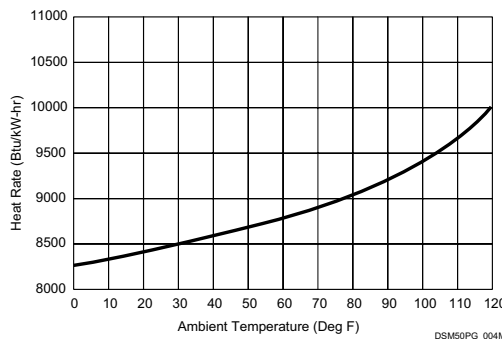

Thermal Efficiency

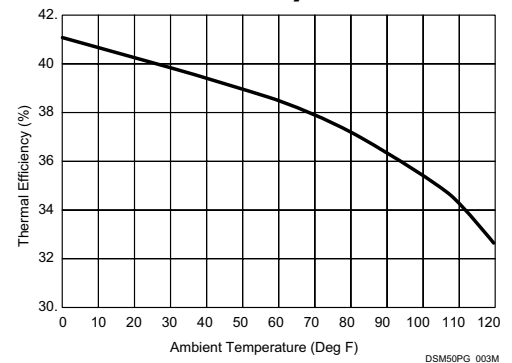

Enclosure Access and Maintenance Space

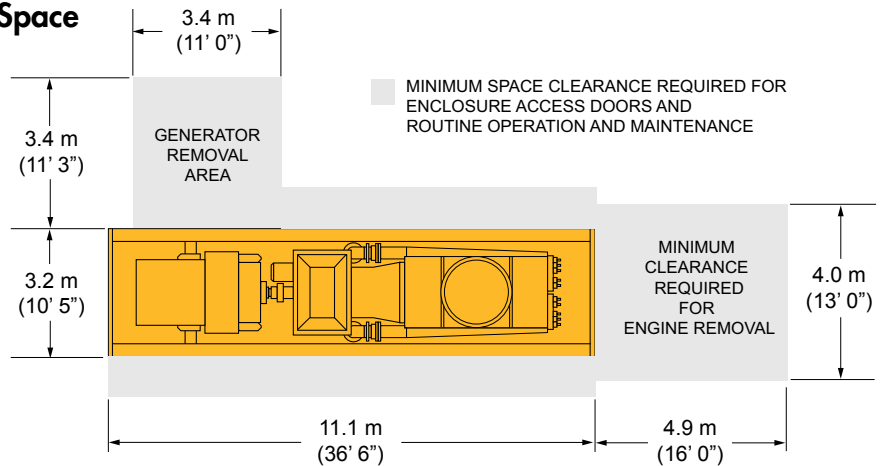

Package Height: 3.7m (12' 3")

Package Weight: 45 700 kg (100,700 lb)

DSM50PG-003C

Solar Turbines Incorporated
P.O. Box 85376
San Diego, CA 92186-5376 U.S.A.

Caterpillar is a trademark of Caterpillar Inc.
Solar, Mercury and Turbotronic are trademarks of Solar Turbines Incorporated.
All other trademarks are the intellectual property of their respective companies.
Specifications subject to change without notice. Printed in U.S.A.
© 2013 Solar Turbines Incorporated. All rights reserved.
DSM50PG/0113/EO

FOR MORE INFORMATION

Telephone: (+1) 619-544-5352
Telefax: (+1) 858-694-6715
email: powergen@soltarturbines.com
Internet: www.soltarturbines.com

