



www.FGWilson.com

Modular Acoustic Enclosures

225 – 275 kVA Range

All FG Wilson weatherproof sound attenuated enclosures are the result of continuing research and development by our specialist acoustic engineers.

The CAL enclosure is designed for operation in regions where compliance with EU noise legislation does not apply.

Alternatively, the CAEU enclosure reduces sound levels to comply with the stage 2 levels of the European Community

Robust/Highly Corrosion Resistant Construction

- Stainless steel locks and hinges
- Zinc plated or stainless steel fasteners
- Body made from steel components treated with polyester powder coating

Transportability

- Optional tested and certified lifting arch
- Lifting points on baseframe
- Oil field type skid with dragging points and fork lift truck pockets - optional



Directive 2000/14/EC which became effective 3 January 2006.

Fully weatherproof, both enclosures incorporate internally mounted exhaust silencers and an extremely rugged construction means both will withstand the rough handling common on many construction sites. They are designed on modular principles with many interchangeable components permitting on site repair.

Security and Safety

- Control panel viewing window in a lockable access door
- Emergency stop push button (red) mounted on enclosure exterior
- Cooling fan and battery charging alternator fully guarded
- Fuel fill and battery can only be reached via lockable access doors
- Exhaust silencing system totally enclosed for operator safety

Excellent Access for Maintenance

- Two large doors on each side
- Radiator fill access plate
- Lube oil drain valves / Coolant drain valves

Sound Pressure Levels (dBA) for 225 – 275 kVA CAL Enclosure

		50 Hz						60 Hz					
		15 m (50 ft)		7 m (23 ft)		1 m (3 ft)		15 m (50 ft)		7 m (23 ft)		1 m (3 ft)	
Generator Set Model		75% Load	100% Load	75% Load	100% Load	75% Load	100% Load	75% Load	100% Load	75% Load	100% Load	75% Load	100% Load
P249H-3	Prime	–	–	–	–	–	–	72.2	72.5	78.2	78.5	90.3	90.6
	Standby	–	–	–	–	–	–	72.3	72.6	78.3	78.6	90.4	90.8
P250H-3	Prime	67.7	68.1	73.7	74.1	86.3	86.6	72.2	72.6	78.2	78.6	90.4	90.7
	Standby	67.8	68.3	73.8	74.3	86.4	86.7	72.3	72.8	78.3	78.8	90.5	90.8
P275H-3	Prime	67.8	68.3	73.8	74.3	86.4	86.7	–	–	–	–	–	–
	Standby	67.9	68.5	73.9	74.5	86.5	86.9	–	–	–	–	–	–

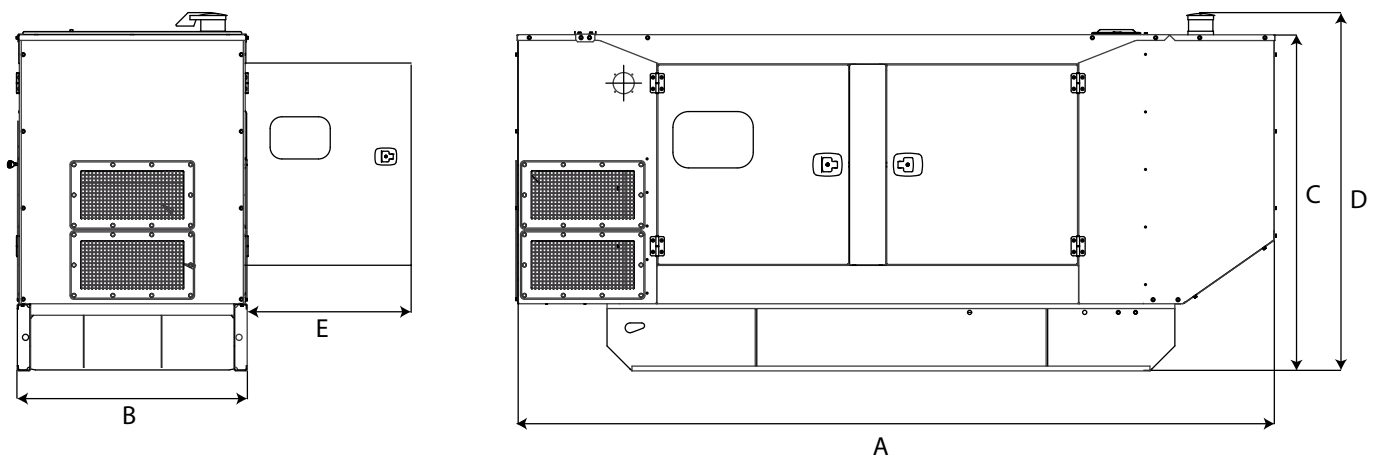

Dimensions and Weights for 225 – 275 kVA CAL Enclosure

Generator Set Model	A: mm (in)	B: mm (in)	C: mm (in)	D: mm (in)	E*: mm (in)	Weight: kg (lb)	Fuel Capacity: l (US gal)
P249H-3	3964 (156.1)	1210 (47.6)	1769 (69.6)	1867 (73.5)	995 (39.2)	2303 (5077)	473 (125)
P250H-3	3964 (156.1)	1210 (47.6)	1769 (69.6)	1867 (73.5)	995 (39.2)	2343 (5165)	473 (125)
P275H-3	3964 (156.1)	1210 (47.6)	1769 (69.6)	1867 (73.5)	995 (39.2)	2343 (5165)	473 (125)

*Clearance required both sides; Weight with lube oil, no coolant, no fuel.

Sound Pressure Levels (dBA) for 225 – 275 kVA CAEU Enclosure

		50 Hz						60 Hz						
		15 m (50 ft)		7 m (23 ft)		1 m (3 ft)		15 m (50 ft)		7 m (23 ft)		1 m (3 ft)		
Generator Set Model		75% Load	100% Load	75% Load	100% Load	75% Load	100% Load	75% Load	100% Load	75% Load	100% Load	75% Load	100% Load	
P249H-3	Prime	–	–	–	–	–	–	66.9	67.2	72.9	73.2	85.4	85.7	
	Standby	–	–	–	–	–	–	67.0	67.4	73.0	73.4	85.4	85.8	
P250H-3	Prime	97	63.7	64.3	69.7	70.3	79.4	80.7	66.0	66.7	72.0	72.7	83.5	84.2
	Standby	97	63.8	64.5	69.8	70.5	79.7	81.3	66.2	67.1	72.2	73.1	83.7	84.5
P275H-3	Prime	97	62.7	63.7	68.7	69.7	80.0	80.8	–	–	–	–	–	
	Standby	97	63.0	64.2	69.0	70.2	80.2	81.3	–	–	–	–	–	

Levels in accordance with European Noise Directive (2000/14/EC).

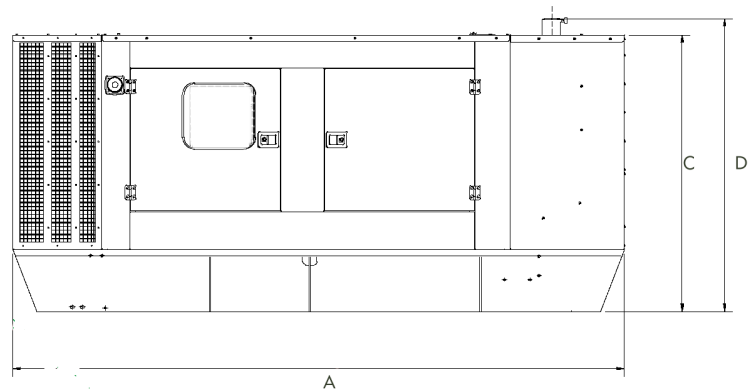
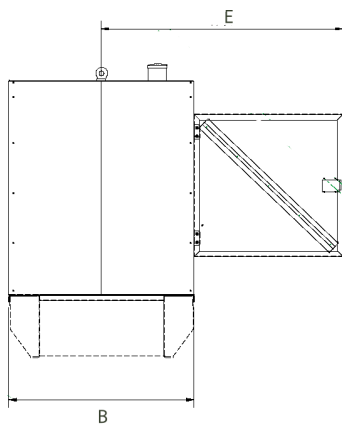

Dimensions and Weights for 225 – 275 kVA CAEU Enclosure

Generator Set Model	A: mm (in)	B: mm (in)	C: mm (in)	D: mm (in)	E*: mm (in)	Weight: kg (lb)	Fuel Capacity: l (US gal)
P249H-3	4294 (169.1)	1300 (51.2)	1875 (73.8)	1996 (78.6)	1050 (41.3)	2970 (6548)	550 (145)
P250H-3	4294 (169.1)	1300 (51.2)	1875 (73.8)	1996 (78.6)	1050 (41.3)	3055 (6735)	550 (145)
P275H-3	4294 (169.1)	1300 (51.2)	1875 (73.8)	1996 (78.6)	1050 (41.3)	3055 (6735)	550 (145)

*Clearance required both sides; Weight with lube oil, no coolant, no fuel.

FG Wilson manufactures product in the following locations:

Northern Ireland • Brazil • China • India • USA

With headquarters in Northern Ireland, FG Wilson operates through a Global Dealer Network.

To contact your local Sales Office please visit the FG Wilson website at www.FGWilson.com.

FG Wilson is a trading name of Caterpillar (NI) Limited.

In line with our policy of continuous product development, we reserve the right to change specification without notice.

225-275kVAEnclosure/0614/GB