

Connections

Perkins newsletter for India

Issue 5 - March 2015

Welcome to the fifth edition of 'Connections' which includes a summary of the EP Seminars in Hyderabad and Bangalore, benefits of a twin actuator, the appointment of Daniel Bentley as the new sales director for the Asia Pacific region, Powerparts' new establishment and our Extended Service Contract (ESC).

A case study on Indiabulls in Mumbai, which is powered by our 4016-61TRG, also features in this issue.

Please keep sending your thoughts and story ideas to
Enquiry_India@perkins.com

Pankaj Kumar Jha, South Asia marketing manager

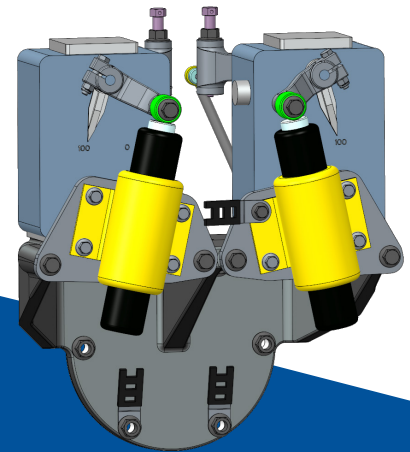

4016-61TRG benefits from introduction of a twin actuator

Listening and responding to our customers' requirements is a key philosophy for Perkins, so in support of continued product improvements, we recently introduced a new twin actuator arrangement on our 4016-61TRG model.

Now, when the engine starts, it will initially run on one bank of cylinders until around 30 percent load when the second bank will cut in. The engine has been designed to automatically alternate the banks that it starts on, for example the first start will be on 'A' bank; the second start will be on 'B' bank and the third will revert to 'A' bank.

The previous mechanical engine fuel stop has been removed, with the fuel stop functionality now contained within the electronic governor software.

Twin actuator benefits include reduced fuel consumption at partial loads and reduction of white smoke on cold start up enabling single bank operation at certain ratings.

For more information on the 4000 Series offering visit www.perkins.com/power

Features

EP seminars in Hyderabad and Bangalore

In a quest to further raise brand visibility in India, Perkins has conducted Electric Power (EP) seminars in Hyderabad and Bangalore to help build product awareness, promote the capabilities of Perkins engines and to create and enhance awareness for the brand in the market. Each EP seminar witnessed participation from over 40 attendees including customers, government officials, Electric Power Companies and consultants. Issues pertaining to power problems and its impact on business were discussed at length and participants shared various perspectives and suggested potential solutions. Experienced professionals from Perkins, its distributors Gmmco Power and Powerparts Private Limited and generator OEMs presented power technology solutions that help to bolster businesses in the EP sector. The team at Perkins India took attendees through a brief presentation on Perkins' history since 1932 and the upcoming 4000 Series facility in Aurangabad.

 **Perkins**[®]

THE HEART OF EVERY GREAT MACHINE

Daniel Bentley - new sales director for Asia



Perkins has appointed Daniel (Dan) Bentley as the new sales director for the Asia Pacific region, which includes India, following Jaz Gill's move to the post of global marketing director.

Dan, who has already spent time talking to and meeting Perkins GOEMs in India, is responsible for engines sales in the region and the development of the aftermarket business. "This is an exciting time for Perkins in India," said Dan, "as we continue to focus on developing our customer relationships, raising awareness of our product offering and prepare to open our purpose built, state-of-the-art 4000 Series manufacturing facility in Aurangabad."

Over the years, Dan who joined the company in 1994 has held a number of roles which have focused on our customers and their requirements from our electric power and industrial products.

"Perkins has a strong brand reputation in the power generation market, where we really have become the engine of choice for today's generator set manufacturers. The recent GOEM meeting in Bangalore was a good opportunity to discuss the customer benefits of working with Perkins, our ongoing product developments and investment in the parts and service network and share the latest information on our Aurangabad facility, which will manufacture a range of dependable, powerful and cost effective engines for this region."

Aurangabad facility nears completion

Located in the Shendra Industrial Area in Aurangabad, the new Perkins® 4000 Series engine manufacturing facility will have the capacity to produce around 3,000 engines per year with the capability to increase to 5,000 units. Due to open in quarter 4 in 2015, the state-of-the-art \$150m facility will serve the growing demand for the 4000 Series engines from India and the wider Asia Pacific region.



Facility view – North



Machine shop



Machine shop



Facility view – South

Indiabulls relies on Perkins power

Overview

Indiabulls Real Estate is one of the largest real estate companies in India with development projects spread across high-end office and commercial complexes, premium residential developments, mega townships, retail spaces, hotel and resorts, state-of-the-art special economic zones and infrastructure development. The company has more than 90 percent of its portfolio in Mumbai, Delhi (NCR) and Chennai markets with Rs. 4,000 crore of land bought through government auctions. The main focus of Indiabulls Real Estate is construction and development of properties, project management, investment advisory and construction services. Indiabulls Real Estate has delivered a record 3.3 million sq ft developed space valued at \$1.75 billion (within four years of inception), which they state is the fastest and largest delivery in value terms by any Indian real estate developer in the same time period. It has partnered with Farallon Capital Management LLC of U.S.A to bring the first Foreign Direct Investment into real estate in the country; is listed on the Mumbai, Luxembourg and Singapore Stock Exchange and has been assigned 'A+' rating.

Background

Indiabulls has installed 6 X 4016-61TRG2 for its power needs in Mumbai for real estate application. These sets are for prime application and have run an average of over 2,500 hours in the last three years since installation. The sets have run in the range of 1,000-6,000 hours from November 2011.

Opportunity

Perkins was selected as the engine supplier for the strength of the product and the brand's value proposition of product support, reliability and total cost of operations. Sterling Generator's relationship with the customer, their deep understanding of the system integration, installation and quality of manufacture all contributed towards winning this prestigious order.

Result

Sterling Generators offered a total back up power solution by setting up 6 X 2000 kVA diesel generating sets powered by Perkins 4016-61TRG2 engines with synchronizing feature. Involved in the design and installation of the diesel generators, Sterling has also provided ongoing product support for the installed sets.

Customer comment

"The product support and capability of Sterling Generators to execute such a critical project and to provide the after-sales service we require has led us to place this order with them," said Kumar Swamy, VP Purchase, Lower Parel, Mumbai India.

For more information:

www.perkins.com/products/power

Company:
Indiabulls Real Estate

Location:
Mumbai, India

Specifications:
6 X 4016-61TRG2 (2000 kVA)

Purpose of application:
Prime operating 200-2,000 hours per year

Installation year:
November 2011

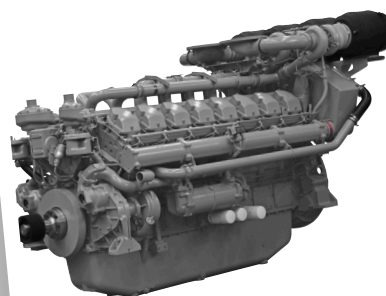

www.sterlinggenerators.com/about-us.html

Benefits of an Extended Service Contract

An Extended Service Contract (ESC) can safeguard your engine from unexpected repairs beyond the standard warranty period and ensures peace of mind. ESC benefits include cost-effective and comprehensive coverage, support of the Perkins global network, fully trained professional Perkins certified technicians to complete all repairs covered by ESCs and genuine Perkins parts, rated and tested specific to your engine. An ESC can be bought at any time during the standard warranty – even the last day by contacting your local distributor or sending your enquires to Enquiry_India@perkins.com

Purchased in minutes, protected for years - Choose from flexible coverage options to suit your needs.

Two protection plans are available to ensure you have flexible options:

Gold – Comprehensive Protection Plan includes 90 percent of engine components covered and protection from labour costs, material costs and travel costs.

Platinum - Total Protection Plan includes 100 percent of engine components covered and protection from labour costs, material.

Is your standard warranty about to expire? Don't miss out on the opportunity to extend your cover.

Powerparts invest in a new facility

Powerparts Private Limited recently relocated its headquarters to a new state-of-the-art facility in Haryana. Spread over four floors, the facility covers a total area of 9,619 square feet.

The new facility houses a fully equipped workshop capable of conducting a major overhaul of the largest 16 cylinder 4000 Series engine. The workshop has separate designated areas for engine teardown and wash, engine rebuild, fuel injection equipment repair and an electrical room. A 7.5 tonne overhead crane has also been installed to enable easy movement of the engines, alongside special tools for overhauling all Perkins engines.

The facility has a Perkins certified trainer and offers Perkins certified training courses for 400, 1100C/D, 2000 and 4000 Series engines. Both the facility and trainer have been audited by Perkins to ensure Perkins' high standards are met. The training classroom comfortably accommodates 15 people and is equipped with necessary training aids. The 4000 Series inline and vee training engines form an integral part of the training. Non-certified courses for diesel generator set

operators on good maintenance practices and maintenance level courses are also on offer.

Located in the facility, the parts warehouse houses inventory of all the major parts required, ensuring an excellent turnaround time. The sales and marketing, product support department, application and installation engineers and back office staff occupy an area of 2,800 square feet with enough room for expansion.

This significant investment is testimony to Powerparts' commitment to Perkins and comes at a time when the Perkins India factory at Aurangabad is nearing completion. With the new facility, Powerparts is well placed to deliver excellent quality of service and product support to the rapidly increasing customer base and OEMs in India.

The new headquarters for Powerparts Private Limited is located at: 114 Pace City 1, Sector 37, Gurgaon, Haryana.



Gmmco Power

Plot No.2B (South Phase), Industrial Estate
Guindy, Chennai, 600 032

Telephone +91 44 30686382

Fax +91 44 30686380

Email: tkv@gmmcoindia.com

www.gmmco.in/power

Powerparts Private Limited

Plot No. 114, Pace City – I, Sector – 37,
Gurgaon – 122 001, Gurgaon, INDIA.

Telephone +91 11 26785137 / 26782119

Email: powerparts@powerparts.in

Perkins India Private Limited

Postal address:

Floor 6, Tower 'B' Prestige Shantiniketan,

The Business Precinct,

Whitefield Main Road,

Bangalore 560048

Email: Enquiry_India@perkins.com

www.perkins.com