



www.FGWilson.com

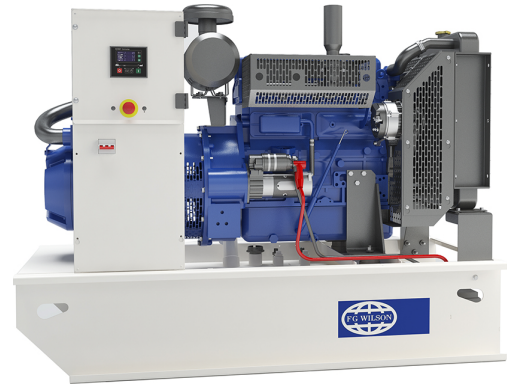

Image for illustration purposes only.

# F50-1

## Output Ratings

Voltage, Frequency	Prime	Standby
400V, 50 Hz	44.6 kVA / 35.7 kW	49.8 kVA / 39.8 kW
480V, 60 Hz	52.5 kVA / 42.0 kW	57.5 kVA / 46.0 kW

Ratings at 0.8 power factor.

Please refer to the output ratings technical data section for specific generator set outputs per voltage.

## Prime Rating

These ratings are applicable for supplying continuous electrical power (at variable load) in lieu of commercially purchased power. There is no limitation to the annual hours of operation and this model can supply 10% overload power for 1 hour in 12 hours.

## Standby Rating

These ratings are applicable for supplying continuous electrical power (at variable load) in the event of a utility power failure. No overload is permitted on these ratings. The alternator on this model is peak continuous rated (as defined in ISO 8528-3).

## Standard Reference Conditions

Note: Standard reference conditions 25°C (77°F) Air Inlet Temp, 100m (328 ft) A.S.L. 30% relative humidity.  
Fuel consumption data at full load with diesel fuel with specific gravity of 0.85 and conforming to BS2869: 1998, Class A2.

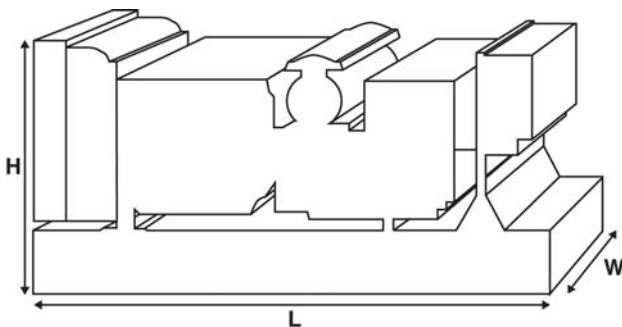

## Ratings and Performance Data

Engine Make & Model:	FG Wilson FD4-5.0A1	
Alternator manufactured for FG Wilson by:	Marelli	
Alternator Model:	MJB 200 SB4	
Control Panel:	DCP-10	
Base Frame:	Heavy Duty Fabricated Steel	
Circuit Breaker Type:	3 Pole MCB	
Frequency:	50 Hz	60 Hz
Engine Speed: rpm	1500	1800
Fuel Tank Capacity: litres (US gal)	180 (47.6)	
Fuel Consumption: l/hr (US gal/hr) (100% Load)	- Prime	11.0 (2.9) 11.5 (3.0)
	- Standby	12.0 (3.2) 12.5 (3.3)

## Available Options

FG Wilson offer a range of optional features to tailor our generator sets to meet your power needs. Options include:

- Upgrade to CE Certification
- A wide range of Sound Attenuated Enclosures
- Additional alarms and shutdowns
- ❷Xi gfr]U`gj`YbWf

For further information on all of the standard and optional features accompanying this product please contact your local Dealer or visit: [www.FGWilson.com](http://www.FGWilson.com)

## Dimensions and Weights

Length (L) mm (in)	Width (W) mm (in)	Height (H) mm (in)	Dry kg (lb)	Wet kg (lb)
1870 (73.6)	840 (33.1)	1482 (58.3)	873 (1925)	888 (1958)

Dry = With Lube Oil

Wet = With Lube Oil and Coolant

Ratings in accordance with ISO 8528, ISO 3046, IEC 60034, BS5000 and NEMA MG-1.22. Generator set pictured may include optional accessories.

Engine Technical Data	
No. of Cylinders / Alignment:	4 / In Line
Cycle:	4 Stroke
Bore / Stroke: mm (in)	108.0 (4.3)/135.0 (5.3)
Induction:	Naturally Aspirated
Cooling Method:	Water
Governing Type:	Electronic
Governing Class:	TBC
Compression Ratio:	17:1
Displacement: l (cu. in)	5.0 (302.1)
Moment of Inertia: kg m <sup>2</sup> (lb/in <sup>2</sup> )	-
Engine Electrical System:	
- Voltage / Ground	12/Negative
- Battery Charger Amps	65
Weight: kg (lb)	
- Dry	490 (1080)
- Wet	510 (1124)

Performance	50 Hz	60 Hz
Engine Speed: rpm	1500	1800
Gross Engine Power: kW (hp)		
- Prime	43.0 (58.0)	50.0 (67.0)
- Standby	48.0 (64.0)	55.0 (74.0)
BMEP: kPa (psi)		
- Prime	696.0 (100.9)	674.0 (97.7)
- Standby	776.0 (112.6)	741.0 (107.5)

Fuel System				
Fuel Filter Type:	Spin On			
Recommended Fuel:	Class A2 Diesel or BSEN590			
Fuel Consumption: l/hr (US gal/hr)				
	110%	100%	75%	50%
Prime	Load	Load	Load	Load
50 Hz	12.0 (3.2)	11.0 (2.9)	8.0 (2.1)	5.8 (1.5)
60 Hz	12.5 (3.3)	11.5 (3.0)	8.8 (2.3)	6.2 (1.6)
		100%	75%	50%
Standby		Load	Load	Load
50 Hz		12.0 (3.2)	9.0 (2.4)	6.8 (1.8)
60 Hz		12.5 (3.3)	9.8 (2.6)	7.3 (1.9)

(Based on diesel fuel with a specific gravity of 0.85 and conforming to BS2869, Class A2)

Air Systems	50 Hz	60 Hz
Air Filter Type:	Replaceable Element	
Combustion Air Flow: m <sup>3</sup> /min (cfm)		
- Prime	-	-
- Standby	3.0 (106)	3.3 (117)
Max. Combustion Air Intake Restriction: kPa (in H <sub>2</sub> O)	5.0 (20.1)	5.0 (20.1)

Cooling System	50 Hz	60 Hz
Cooling System Capacity: l (US gal)	13.0 (3.4)	13.0 (3.4)
Water Pump Type:	Centrifugal	
Heat Rejected to Water & Lube Oil:		
kW (Btu/min)		
- Prime	-	-
- Standby	-	-
Heat Radiation to Room: Heat radiated from engine and alternator		
kW (Btu/min)		
- Prime	-	-
- Standby	-	-
Radiator Fan Load: kW (hp)	3.1 (4.2)	3.7 (5.0)
Radiator Cooling Airflow: m <sup>3</sup> /min (cfm)	132.0 (4662)	144.0 (5085)
External Restriction to Cooling Airflow: Pa (in H <sub>2</sub> O)	125 (0.5)	125 (0.5)

Designed to operate in ambient conditions up to 50°C (122°F).  
Contact your local FG Wilson Dealer for power ratings at specific site conditions.

Lubrication System	
Oil Filter Type:	Spin-On, Full Flow
Total Oil Capacity: l (US gal)	14.0 (3.7)
Oil Pan: l (US gal)	-
Oil Type:	15W-40 CD
Oil Cooling Method:	Water

Exhaust System	50 Hz	60 Hz
Maximum Allowable Back Pressure: kPa (in Hg)	6.0 (1.8)	6.0 (1.8)
Exhaust Gas Flow: m <sup>3</sup> /min (cfm)		
- Prime	-	-
- Standby	7.0 (246)	7.8 (275)
Exhaust Gas Temperature: °C (°F)		
- Prime	-	-
- Standby	-	565 (1049)

Alternator Physical Data	
Manufactured for FG Wilson by:	Marelli
Model:	MJB 200 SB4
No. of Bearings:	1
Insulation Class:	H
Winding Pitch Code:	2/3 - M0
Wires:	12
Ingress Protection Rating:	IP23
Excitation System:	SHUNT
AVR Model:	Mark V

Alternator Operating Data	
Overspeed: rpm	2250
Voltage Regulation: (Steady state)	+/- 0.5%
Wave Form NEMA = TIF:	50
Wave Form IEC = THF:	2.0%
Total Harmonic content LL/LN:	2.0%
Radio Interference:	Suppression is in line with European Standard EN55011
Radiant Heat: kW (Btu/min)	
- 50 Hz	5.3 (301)
- 60 Hz	6.2 (353)

Alternator Performance Data:	50 Hz			60 Hz		
	415/240V	400/230V	380/220V	480/277V 240/139V	380/220V	440/254V 220/127V
<b>Data Item</b>						
Motor Starting Capability* kVA	59	55	50	66	41	55
Short Circuit Capacity %	-	-	-	-	-	-
Reactances: Per Unit						
Xd	3.134	3.381	3.712	3.316	3.790	3.942
X'd	0.283	0.305	0.335	0.299	0.432	0.356
X''d	0.120	0.129	0.142	0.127	0.183	0.151

Reactances shown are applicable to prime ratings.  
 \*Based on 30% voltage dip at 0.0 power factor and SHUNT excitation.

Output Ratings Technical Data 50 Hz				
Voltage	Prime:		Standby:	
	kVA	kW	kVA	kW
415/240V	44.5	35.6	49.8	39.8
400/230V	44.6	35.7	49.8	39.8
380/220V	44.2	35.4	49.3	39.4

Output Ratings Technical Data 60 Hz				
Voltage	Prime:		Standby:	
	kVA	kW	kVA	kW
480/277V	52.5	42.0	57.5	46.0
220/127V	52.5	42.0	57.5	46.0
380/220V	47.5	38.0	52.3	41.8
440/254V	52.5	42.0	57.5	46.0
240/139V	52.5	42.0	57.5	46.0

**Documentation**

A full set of operation and maintenance manuals and circuit wiring diagrams.

**Generator Set Standards**

The equipment meets the following standards: BS5000, ISO 8528, ISO 3046, IEC 60034, NEMA MG-1.22.

FG Wilson is a fully accredited ISO 9001 company.

**Warranty**

All prime equipment, limited to 2,000 running hours per year, has a one year manufacturer's warranty. Standby equipment, limited to 500 running hours per year, has a two year manufacturer's warranty. For details on warranty cover please contact your local Dealer, or visit our website: [FGWilson.com](http://FGWilson.com).

**Dealer contact details:**

**FG Wilson manufactures product in the following locations:**

Northern Ireland • Brazil • China • India • USA

With headquarters in Northern Ireland, FG Wilson operates through a Global Dealer Network.

To contact your local Sales Office please visit the FG Wilson website at [www.FGWilson.com](http://www.FGWilson.com).

FG Wilson is a trading name of Caterpillar (NI) Limited.