



www.FGWilson.com

# P165-5



Image for illustration purposes only.

## Output Ratings

Voltage, Frequency	Prime	Standby
400V, 50 Hz	150.0 kVA / 120.0 kW	165.0 kVA / 132.0 kW
480V, 60 Hz	168.8 kVA / 135.0 kW	187.5 kVA / 150.0 kW

Ratings at 0.8 power factor.

Please refer to the output ratings technical data section for specific generator set outputs per voltage.

## Prime Rating

These ratings are applicable for supplying continuous electrical power (at variable load) in lieu of commercially purchased power. There is no limitation to the annual hours of operation and this model can supply 10% overload power for 1 hour in 12 hours.

## Standby Rating

These ratings are applicable for supplying continuous electrical power (at variable load) in the event of a utility power failure. No overload is permitted on these ratings. The alternator on this model is peak continuous rated (as defined in ISO 8528-3).

## Standard Reference Conditions

Note: Standard reference conditions 25°C (77°F) Air Inlet Temp, 100m (328 ft) A.S.L. 30% relative humidity.  
Fuel consumption data at full load with diesel fuel with specific gravity of 0.85 and conforming to BS2869: 1998, Class A2.

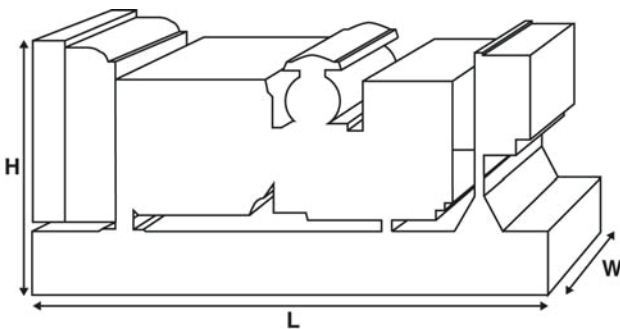

## Ratings and Performance Data

Engine Make & Model:	Perkins 1106A-70TAG2	
Alternator manufactured for FG Wilson by:	Marelli	
Alternator Model:	MJB 250 MA4	
Control Panel:	DCP-10	
Base Frame:	Heavy Duty Fabricated Steel	
Circuit Breaker Type:	3 Pole MCCB	
Frequency:	50 Hz	60 Hz
Engine Speed: rpm	1500	1800
Fuel Tank Capacity: litres (US gal)	327 (86.4)	
Fuel Consumption: l/hr (US gal/hr) (100% Load)	- Prime	32.4 (8.6) 37.9 (10.0)
	- Standby	35.1 (9.3) 41.6 (11.0)

## Available Options

FG Wilson offer a range of optional features to tailor our generator sets to meet your power needs. Options include:

- Upgrade to CE Certification
- A wide range of Sound Attenuated Enclosures
- A variety of generator set control and synchronising panels
- Additional alarms and shutdowns
- A selection of exhaust silencer noise levels

For further information on all of the standard and optional features accompanying this product please contact your local Dealer or visit: [www.FGWilson.com](http://www.FGWilson.com)

## Dimensions and Weights

Length (L) mm (in)	Width (W) mm (in)	Height (H) mm (in)	Dry kg (lb)	Wet kg (lb)
2450 (96.5)	1010 (39.8)	1544 (60.8)	1545 (3406)	1566 (3452)

Dry = With Lube Oil

Wet = With Lube Oil and Coolant

Ratings in accordance with ISO 8528, ISO 3046, IEC 60034, BS5000 and NEMA MG-1.22. Generator set pictured may include optional accessories.

Engine Technical Data	
<b>No. of Cylinders / Alignment:</b>	6 / In Line
<b>Cycle:</b>	4 Stroke
<b>Bore / Stroke:</b> mm (in)	105.0 (4.1)/135.0 (5.3)
<b>Induction:</b>	Turbocharged Air To Air Charge Cooled
<b>Cooling Method:</b>	Water
<b>Governing Type:</b>	Mechanical
<b>Governing Class:</b>	ISO 8528 G2
<b>Compression Ratio:</b>	16.0:1
<b>Displacement:</b> l (cu. in)	7.0 (427.8)
<b>Moment of Inertia:</b> kg m <sup>2</sup> (lb/in <sup>2</sup> )	1.53 (5228)
<b>Engine Electrical System:</b>	
- Voltage / Ground	12/Negative
- Battery Charger Amps	85
<b>Weight:</b> kg (lb)	
- Dry	788 (1737)
- Wet	822 (1812)

Performance	50 Hz	60 Hz
<b>Engine Speed:</b> rpm	1500	1800
<b>Gross Engine Power:</b> kW (hp)		
- Prime	136.0 (182.0)	155.4 (208.0)
- Standby	149.1 (200.0)	171.8 (230.0)
<b>BMEP:</b> kPa (psi)		
- Prime	1551.0 (225.0)	1477.0 (214.2)
- Standby	1701.0 (246.7)	1633.0 (236.8)

Fuel System				
<b>Fuel Filter Type:</b>	Replaceable Element			
<b>Recommended Fuel:</b>	Class A2 Diesel or BSEN590			
<b>Fuel Consumption:</b> l/hr (US gal/hr)				
	110%	100%	75%	50%
<b>Prime</b>	<b>Load</b>	<b>Load</b>	<b>Load</b>	<b>Load</b>
50 Hz	35.1 (9.3)	32.4 (8.6)	25.0 (6.6)	16.7 (4.4)
60 Hz	41.6 (11.0)	37.9 (10.0)	29.2 (7.7)	19.9 (5.3)
	100%	75%	50%	
<b>Standby</b>	<b>Load</b>	<b>Load</b>	<b>Load</b>	
50 Hz	35.1 (9.3)	27.3 (7.2)	18.4 (4.9)	
60 Hz	41.6 (11.0)	32.1 (8.5)	22.0 (5.8)	

(Based on diesel fuel with a specific gravity of 0.85 and conforming to BS2869, Class A2)

Air Systems	50 Hz	60 Hz
<b>Air Filter Type:</b>	Paper Element	
<b>Combustion Air Flow:</b> m <sup>3</sup> /min (cfm)		
- Prime	10.0 (354)	14.4 (509)
- Standby	10.7 (377)	15.0 (529)
<b>Max. Combustion Air Intake Restriction:</b> kPa (in H <sub>2</sub> O)	3.0 (12.0)	3.0 (12.0)

Cooling System	50 Hz	60 Hz
<b>Cooling System Capacity:</b> l (US gal)	21.0 (5.5)	21.0 (5.5)
<b>Water Pump Type:</b> Centrifugal		
<b>Heat Rejected to Water &amp; Lube Oil:</b>		
kW (Btu/min)	- Prime	69.1 (3930) 73.5 (4180)
	- Standby	75.7 (4305) 80.1 (4555)
<b>Heat Radiation to Room:</b> Heat radiated from engine and alternator		
kW (Btu/min)	- Prime	20.0 (1137) 22.6 (1285)
	- Standby	22.3 (1268) 25.0 (1422)
<b>Radiator Fan Load:</b> kW (hp)	4.5 (6.0)	8.0 (10.7)
<b>Radiator Cooling Airflow:</b> m <sup>3</sup> /min (cfm)	259.2 (9154)	316.2 (11167)
<b>External Restriction to Cooling Airflow:</b> Pa (in H <sub>2</sub> O)	125 (0.5)	125 (0.5)

Designed to operate in ambient conditions up to 50°C (122°F). Contact your local FG Wilson Dealer for power ratings at specific site conditions.

Lubrication System	
<b>Oil Filter Type:</b>	Spin-On, Full Flow
<b>Total Oil Capacity:</b> l (US gal)	16.5 (4.4)
<b>Oil Pan:</b> l (US gal)	14.9 (3.9)
<b>Oil Type:</b>	API CH4 / CI4 15W-40
<b>Oil Cooling Method:</b>	Water

Exhaust System	50 Hz	60 Hz
<b>Maximum Allowable Back Pressure:</b> kPa (in Hg)	6.0 (1.8)	6.0 (1.8)
<b>Exhaust Gas Flow:</b> m <sup>3</sup> /min (cfm)		
- Prime	23.9 (843)	31.9 (1125)
- Standby	25.5 (902)	32.2 (1137)
<b>Exhaust Gas Temperature:</b> °C (°F)		
- Prime	484 (903)	407 (765)
- Standby	484 (903)	407 (765)

Alternator Physical Data	
Manufactured for FG Wilson by:	Marelli
Model:	MJB 250 MA4
No. of Bearings:	1
Insulation Class:	H
Winding Pitch Code:	2/3 - M0
Wires:	12
Ingress Protection Rating:	IP23
Excitation System:	SHUNT
AVR Model:	Mark V

Alternator Operating Data		
Overspeed: rpm	2250	
Voltage Regulation: (Steady state)	+/- 0.5%	
Wave Form NEMA = TIF:	50	
Wave Form IEC = THF:	2.0%	
Total Harmonic content LL/LN:	2.0%	
Radio Interference:	Suppression is in line with European Standard EN61000-6	
Radiant Heat: kW (Btu/min)		
	- 50 Hz	10.1 (574)
	- 60 Hz	12.7 (722)

Alternator Performance Data:	50 Hz				60 Hz			
	415/240V	400/230V	380/220V	220/127V	480/277V	380/220V	240/120V	440/254V
Data Item								
		230/115V	220/110V		240/139V	220/110V	208/120V	220/127V
		200/115V						
Motor Starting Capability* kVA	232	218	194	261	211	161	187	195
Short Circuit Capacity** %	-	-	-	-	-	-	-	-
Reactances: Per Unit								
Xd	2.750	2.960	3.280	2.450	2.780	3.350	3.700	3.310
X'd	0.240	0.260	0.290	0.210	0.240	0.390	0.320	0.290
X''d	0.101	0.109	0.121	0.090	0.102	0.163	0.136	0.122

Reactances shown are applicable to prime ratings.  
 \*Based on 30% voltage dip at 0.6 power factor and SHUNT excitation.  
 \*\*With optional permanent magnet generator or AREP excitation.

Output Ratings Technical Data 50 Hz				
Voltage	Prime:		Standby:	
	kVA	kW	kVA	kW
415/240V	150.0	120.0	165.0	132.0
400/230V	150.0	120.0	165.0	132.0
380/220V	150.0	120.0	165.0	132.0
230/115V	150.0	120.0	165.0	132.0
220/127V	150.0	120.0	165.0	132.0
220/110V	150.0	120.0	165.0	132.0
200/115V	150.0	120.0	165.0	132.0

Output Ratings Technical Data 60 Hz				
Voltage	Prime:		Standby:	
	kVA	kW	kVA	kW
480/277V	168.8	135.0	187.5	150.0
220/127V	168.8	135.0	187.5	150.0
380/220V	168.8	135.0	185.0	148.0
240/120V	168.8	135.0	187.5	150.0
440/254V	168.8	135.0	187.5	150.0
220/110V	168.8	135.0	185.0	148.0
208/120V	168.8	135.0	187.5	150.0
240/139V	168.8	135.0	187.5	150.0

**Documentation**

A full set of operation and maintenance manuals and circuit wiring diagrams.

**Generator Set Standards**

The equipment meets the following standards: BS5000, ISO 8528, ISO 3046, IEC 60034, NEMA MG-1.22.

FG Wilson is a fully accredited ISO 9001 company.

EU stage IIIA emissions compliant.

**Warranty**

All prime equipment carries a one year manufacturer's warranty. Standby equipment, limited to 500 running hours per year, has a two year manufacturer's warranty. For details on warranty cover please contact your local Dealer, or visit our website: [FGWilson.com](http://FGWilson.com).

**Dealer contact details:**

**FG Wilson manufactures product in the following locations:**

Northern Ireland • Brazil • China • India • USA

With headquarters in Northern Ireland, FG Wilson operates through a Global Dealer Network.

To contact your local Sales Office please visit the FG Wilson website at [www.FGWilson.com](http://www.FGWilson.com).

FG Wilson is a trading name of Caterpillar (NI) Limited.