



Cat® CP34

PADFOOT DRUM VIBRATORY SOIL COMPACTOR

FEATURES:

The Cat® CP34 features a padfoot drum and is ideally suited for cohesive and semi-cohesive soil applications:

- **Comfortable and ergonomic operator station** features an adjustable seat, multifunction LCD display and control console, outstanding visibility to the front and rear of machine, low sound levels and vibration for greater operator comfort and productivity.
- **World-class propel system** built around the exclusive Cat dual pump propel system, two pumps provide separate dedicated flow to drum drive motor and rear axle motor for exceptional gradeability and traction in forward and reverse.
- **Cat C3.4B Engine** is efficient, powerful and meets US EPA Tier 4 Final and EU Stage IV emission standards.
- **More Uptime and Lower Maintenance Costs** due to ground level access and extended maintenance intervals.
- **Standard Leveling Blade** increases machine utilization for backfilling, material knockdown and light dozing applications.
- **Involuted Oval Padfoot Design** provides more lift penetration for deeper compaction.

Specifications

Engine - Power Train

Engine Model	Cat C3.4B	
Global Emissions	US EPA Tier 4 Final/ EU Stage IV	
Gross Power ISO 14396	55 kW	74 hp
Displacement	3.4 L	207 in ³
Stroke	110 mm	4.33 in
Bore	99 mm	3.89 in
Max. Travel Speed (Forward or Reverse)	8.9 km/h	5.5 mph

Weights

Operating Weight w/ ROPS/FOPS canopy and Leveling Blade	4995 kg	11,000 lb
Weight at Drum w/ ROPS/FOPS canopy and Leveling Blade	2640 kg	5,820 lb

Vibratory System Specifications

Frequency	35 Hz	2100 vpm
Nominal Amplitude	1.3 mm	0.05 in
Centrifugal Force	66.8 kN	15,000 lb

Service Refill Capacities

Fuel Tank, total capacity	113 L	30 gal
Cooling System	20.8 L	5.5 gal
Engine Oil w/ Filter	8 L	2.1 gal
Eccentric Weight Housings	25.4 L	6.7 gal
Axle and Final Drives	8 L	2.1 gal
Hydraulic Tank (service refill)	40 L	10.6 gal

CP34 Vibratory Soil Compactor

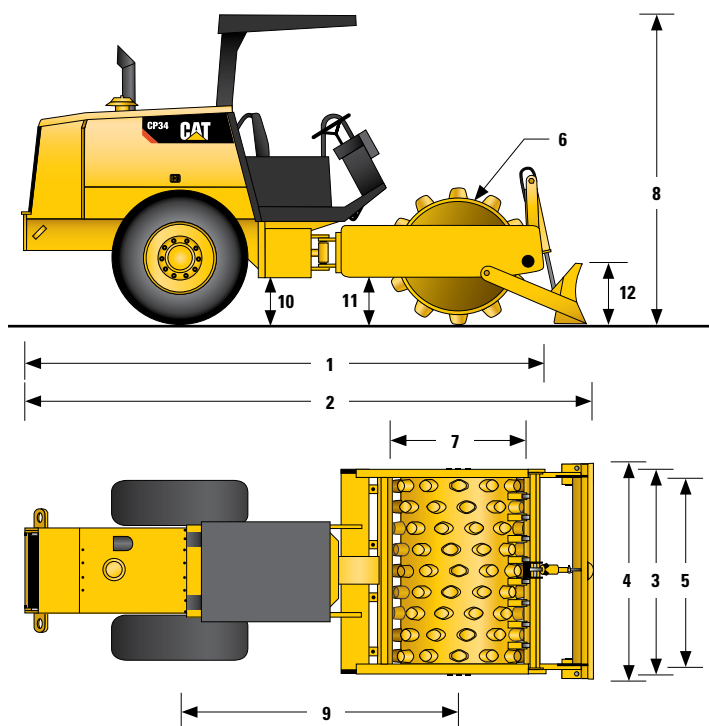

Dimensions

1 Machine Length	4.15 m	13.7 ft
2 Overall Length with Leveling Blade	4.58 m	15 ft
3 Machine Width	1.39 m	4.5 ft
4 Overall Width with Leveling Blade	1.57 m	5.17 ft
5 Drum Width	1270 mm	50 in
6 Drum Shell Thickness	20 mm	0.78 in
7 Drum Diameter (over pads)	1016 mm	40 in
8 Maximum Height	2.51 m	8.17 ft
9 Wheelbase	2.24 m	7.33 ft
10 Ground Clearance	347 mm	13.6 in
11 Curb Clearance	335 mm	13.2 in
12 Leveling Blade Height	558 mm	22 in
Inside Turning Radius	2.62 m	12.75 ft
Hitch Articulation Angle	38°	
Hitch Oscillation Angle	15°	

Padfoot Specifications

Number of Pads	88	
Pad Height	88 mm	3.5 in
Pad Face Area	79.3 cm ²	12.3 in ²
Number of Chevrons	11	

STANDARD EQUIPMENT

ELECTRICAL

- 12 volt Electrical System
- 120 ampere Alternator
- 750 Cold-cranking Amps Battery Capacity

OPERATOR ENVIRONMENT

- ROPS/FOPS Platform
- Vinyl Adjustable Seat with Control Console, Seat Belt
- Multifunction LCD Display with gauges and audible warning alarm for: *Hydraulic oil temperature, Engine oil pressure, Engine coolant temperature, Alternator charge, Fuel level, Service hour meter, Engine RPM, Fuel rate, Engine load*
- Platform Handrails/Guardrails
- Lockable Vandalism Guard on LCD Display
- 12-volt Power Outlet
- Rear View Mirror
- Horn, Backup Alarm

POWERTRAIN

- Cat C3.4B Turbo-charged Diesel Engine
- Glow-plug Heater
- Dual Element Air Cleaner
- Two-speed Throttle Switch
- Dual Propel Pumps; One for Drum Drive, One for Rear Axle
- Fuel Filter, Water Separator, Manual Priming Pump, Water Indicator
- Radiator/Hydraulic Oil Cooler
- Dual Braking System
- Single-speed Hydrostatic Transmission
- Limited Slip Differential

VIBRATORY SYSTEM

- Padfoot Drum
- Single Amplitude, Single Frequency
- Front Adjustable Steel Scraper

OTHER

- Leveling Blade
- Hydraulic Oil Level Sight Gauge
- Radiator Coolant Level Sight Gauge
- Quick-connect Hydraulic Pressure Test Ports
- S-O-SSM Sampling Ports: Engine Oil, Coolant and Hydraulic Oil
- Lockable Engine Enclosure, Hydraulic and Fuel Tanks
- Tilting Operator Platform
- 8-ply Traction Tires
- Transportation Lift Points and Tie-downs

For more complete information on Cat products, dealer services, and industry solutions, visit us on the web at www.cat.com

QEHQ1849 (11-14)

© 2014 Caterpillar
All Rights Reserved
Printed in U.S.A.

Weights and dimensions listed are approximate. Materials and specifications are subject to change without notice. Featured machines in photos may include additional equipment. See your Cat dealer for available options.

CAT, CATERPILLAR, SAFETY.CAT.COM, their respective logos, "Caterpillar Yellow" and the "Power Edge" trade dress, as well as corporate and product identity used herein, are trademarks of Caterpillar and may not be used without permission.

