

740C EJ

Articulated Truck



Engine

Engine Model – U.S. EPA Tier 2/EU Stage II	Cat® C18 ACERT™	
Gross Power – SAE J1995	381 kW	511 hp
Net Power – SAE J1349	370 kW	496 hp
Net Power – ISO 14396	376 kW	504 hp

Weights

Rated Payload	38 tonnes	42 tons
---------------	-----------	---------

Body Capacities

Heaped SAE 2:1	23 m ³	30.1 yd ³
----------------	-------------------	----------------------

740C EJ Articulated Truck Key Features

- *Cat C18 Advanced Combustion Emissions Reduction Technology ACERT engine meeting Tier 2/Stage II equivalent emission standards*
- *Cat engine compression brake*
- *Automatic Retarder Control (ARC)*
- *Advanced Productivity Electronic Control Strategy (APECS)*
- *Enhanced Automatic Traction Control (ATC)*
- *Color Multi-Purpose Display (CMPD)*
- *Hill Assist*
- *Waiting Brake*
- *Site Speed Limiting*
- *Integrated Technologies – Cat Production Measurement, Product Link™/VisionLink®*
- *High Density Power Shift (HDPS) transmission with matched OTG*
- *All axle wet brakes*
- *Wide tire option*

Contents

Engine	4
Transmission	6
Automatic Features	7
Suspension and Braking	8
Operator Environment	9
Ease of Operation	10
Durability and Reliability	12
Integrated Technologies	13
Versatility	14
Serviceability	15
Complete Customer Support	16
Sustainability	17
Safety	18
Specifications	19
Standard Equipment	25
Optional Equipment	26
Notes	27





The Cat 740C EJ with a 23 m³ (30.1 yd³) 38 tonnes (42 ton) capacity offers proven reliability, durability, high productivity, superior operator comfort and lower operating costs.

With a focus on unique, adaptable productivity, the 740C EJ has many updated and improved features, an all new power train and new ease of operation features including Automatic Retarder Control.

Engine

Optimized performance, proven reliability





Every Cat engine with ACERT Technology is equipped with a combination of proven electronic, fuel, air and aftertreatment components. The right technologies fine-tuned for the right applications result in:

- Improved fluid efficiency of up to 5% improvement over Tier 4 Interim/Stage IIIB products.
- High machine performance across a variety of applications.
- Enhanced reliability through commonality and simplicity of design.
- Maximized uptime and reduced cost with world-class support from the Cat dealer network.
- Durable designs with long life to overhaul.
- Delivering better fuel economy with minimized maintenance costs while providing the same great power and response.

Advanced MEUI™-C Injector

Advanced MEUI-C injector platforms deliver increased injection pressures and more precise fuel rates. These durable injectors enhance responsiveness while controlling soot.

Innovative Air Management

Cat engines feature innovative air-management systems that optimize airflow and enhance power, efficiency and reliability.

Engine Compression Brake

The engine compression brake improves retarding response and increases retarding power for controlled descent of grades.

Transmission

Class leading transmission technology



The new Cat High Density Power Shift (HDPS) nine-speed forward two-speed reverse transmission features Advanced Productivity Electronic Control Strategy (APECS) and Electronic Clutch Pressure Control (ECPC) which deliver smooth gear changes with improved acceleration and higher productivity.

Rimpull has been increased in both forward and reverse.

Speed hold/limiting function allows the machine speed to be limited in 1 km/h or 1 mph steps to conform to site speed restrictions.

Gearshifts have been significantly improved to maintain direct drive lock-up, and reduce dropping into converter drive. This helps maintain ground speed and gradeability.

Works in conjunction with the engine brake to automatically reduce the retarding level on lesser grades in lower gears.

Variable shift points used based on the operating conditions, which also aid in maintaining ground speed during gear changes on grades.

Torque Converter

Larger diameter torque converter, configured for off highway applications, allows the higher engine power to be transmitted more efficiently to the lower power train.

Automatic Features

Ease of use, improved performance



Automatic Traction Control (ATC)

The ATC system successfully introduced on the B Series has been further enhanced for even better performance. Application of the inter and cross-axle differential locks is 'on-the-go' and fully automatic. The operator does not have to think about when and where to engage either diff lock. Sensors monitor the machine and wheel speeds, enabling instant response in low traction conditions. Operation is seamless and smooth, eliminating wheel slip for maximum traction and therefore productivity.

Clutches are automatically disengaged when ground conditions allow, maximizing efficiency when steering or on uneven ground.

ATC reduces tire and driveline abuse, eliminating lost efficiency caused by improper manual operation of the differential clutches, and reducing the cost of premature tire replacement.

Automatic Retarder Control (ARC)

In automatic mode, use of the retarder is much easier for the operator. As with ATC a number of machine operating aspects are monitored, and if required the engine compression brake is engaged automatically. The system can help towards eliminating engine overspeed, improving safe machine operation and reducing cycle times, yet still with the flexibility of manual control if needed.



Suspension and Braking

Performance with comfort

Front Suspension

The three-point front suspension oscillates $\pm 6^\circ$ to provide a smooth ride, allowing the operator to travel at speed over rough terrain and softening impact loads on structures and components. Large bore, low-pressure cylinders are purpose designed for tough applications and offer a soft, smooth ride.

A-Frame Construction

The front suspension uses an oscillating A-frame with a lateral tie rod to control axle sideways movement and stability.

Rear Suspension

Features a walking beam with Caterpillar designed rear suspension mounts, which have long life and provide a reliable, and stable ride for excellent load retention.

Mounting Points

Suspension mounting points are integrated into the axle housing, increasing reliability.

All Axle Enclosed Wet Brakes

Provide smoother retarding and braking, with improved holding in slippery conditions and on grades.

Hill Assist

Eliminates potential 'roll-back' on grades. If an operator stops the machine on a grade, when taking his foot off the service brake pedal the machine will automatically hold the service brakes on for a number of seconds to prevent the machine from rolling backwards.



Ride Comfort

The three-point front suspension with its oscillating axle and low-pressure ride struts, combined with the center-mounted cab, offers unrivaled levels of ride comfort for the operator in all driving conditions. The operator remains comfortable and productive throughout the day.

Operator Environment

Improved productivity with a comfortable and confident operator

Spacious Two-Person Cab

The large two-person cab offers a comfortable working space for both the operator and a passenger. The passenger seat is fully padded with a backrest and a wide, retractable seat belt for a secure and comfortable ride. It is also positioned adjacent to the operator, giving both the operator and passenger a clear view of the instrument panel, controls and the road. The storage space behind the operator seat has been increased, and access improved. The design and layout is common across all C Series Articulated Trucks.

Air Suspension Seat

The air suspension seat provides improved operator comfort with a cushioned upper high back, adjustable damping with three settings, ride zone indicator and adjustable lumbar settings. It is fully adjustable to provide the optimal driving position.

Cab Atmosphere

The air conditioning system helps to keep you comfortable whatever environment you are operating in.

Waiting Brake

As the name implies, anywhere you are waiting you can use this feature to remove the need for repeated application of the parking brake. For example, if you are holding the machine on a grade, in a loading or dump area, select neutral and press the yellow button on the gear select cane. This will automatically apply the service brakes, without the need to apply the park brake. To disengage, put the machine in gear and the brakes are released.

Ease of Operation

Designed around the operator





Control Layout

The cab is designed to make all aspects of machine operation as simple as possible. The controls and gauges are easy to read and straightforward to operate. The controls and gauges allow the operator to focus on safe machine operation while maintaining productivity.

Dashboard

The integrated wrap-around dash puts all controls within easy reach of the operator. Featuring LED illuminated rocker switches for the dash dimmer, rear wash wiper, hazard warning, work lamp, secondary steer, A/C and cigar lighter. Delivers an automotive feel with the industrial strength you would expect from Caterpillar.

Color Multi Purpose Display (CMPD)

The dash mounted display unit shows the operator various levels of performance and condition pages as well as machine warning categories. These include performance data, configuration settings, operator and machine totals, service information, various machine status parameters, machine payload information (when fitted), and the video feed from the rearview camera.

Bluetooth™ Stereo Connectivity

Make and receive calls via Bluetooth equipped mobile.





Durability and Reliability

Proven structures and components

Front Frame

The front frame design features a large box section and wide, stiff frame beams to handle torque loads. The divergent frame design decreases stress in the hitch area and optimizes suspension geometry. The frame design makes maximum use of robotic welding for increased durability.

Rear Frame

Twin-box construction minimizes stress concentrations and provides low weight with long service life.

Suspension

The three-point oscillating axle front suspension provides unparalleled ride quality. It also protects the truck from adverse road conditions by absorbing shock loads that would reach the frame.

Articulating/Oscillating Hitch

The articulating hitch provides the truck with steering articulation, and the oscillation ensures all-wheel ground contact in rough terrain.

Hitch Construction

Field proven two-piece construction features a durable cast steel head bolted to a hard wearing forged steel tube.

Dump Body Design

The 740C EJ has a large target area to provide consistently high load-carrying capacity. Its ejecting mechanism gives clean material discharge, which maximizes production and avoids the waste of carry-back.

Output Transfer Gear

Distributes drive to the tractor and trailer and includes a wet clutch differential lock for optimum traction in poor underfoot conditions.

Service Brakes

Dual-circuit, all wheel braking system. The full power hydraulic system actuates enclosed, oil immersed, multi disc, multi plate brakes with independent front and rear circuits and accumulators.

Parking Brake

Located on the center axle in an elevated position, it is spring applied and hydraulically released.

Integrated Technologies

The right information at the right time



LINK Technologies

LINK technologies, like Product Link wirelessly connect you to your equipment, giving you valuable insight into how your machine or fleet is performing. The system tracks location, hours, fuel usage, productivity, idle time, and diagnostic codes through the online VisionLink user interface so you can make timely, fact-based decisions to maximize efficiency, improve productivity, and lower costs.

PAYLOAD Technologies

PAYLOAD technologies like Cat Production Measurement bring payload weighing to the cab to help optimize job site efficiency and productivity. Operators can view real-time load weights on the integrated display and know precisely when target is achieved, while cab-mounted external payload lights signal the loader operator when to stop loading to reduce overloading. Operators can track daily productivity from the cab, with quick access to truck payload weights, loads and cycle counts, and daily totals; or remotely via LINK technologies.

CAT CONNECT makes smart use of technology and services to improve your job site efficiency. Using the data from technology-equipped machines, you'll get more information and insight into your equipment and operations than ever before.

Cat Connect technologies offers improvements in these key areas:



EQUIPMENT
MANAGEMENT

Equipment Management – increase uptime and reduce operating costs.



PRODUCTIVITY

Productivity – monitor production and manage job site efficiency.



SAFETY

Safety – enhance job site awareness to keep your people and equipment safe.

Versatility

Stretch the operating envelope



The 740C EJ shares the versatility of the standard 735C and 745C Series Articulated Trucks, operating in the same conditions, but offering unique capabilities that stretch the operation envelope.

Ejector

The ejector body offers clean load ejection 'on-the-go' and the capability to work safely in areas with restricted overhead clearance and soft underfoot conditions.

Spreading

The truck can eject and spread the material while moving, reducing additional spreading and dozing equipment. 'On-the-go' ejecting results in faster cycle times and reduced power train loads.

Stability

Ejecting the load without raising the body increases stability, allowing load dispersal on inclines, side slopes and in very soft underfoot conditions especially on landfill sites.

Overhead Clearance

The truck can eject in areas with reduced overhead clearance, such as around overhead lines or in tunneling and underground operations.

Carry-Back

The body design eliminates material sticking to the body, which increases productivity, improves fuel efficiency and lowers cost per ton.

Body

Reinforced body is made from thick high-yield, heat-treated Brinell hardened steel (Brinell 450 on the base and sides) that provides exceptional durability. Ejector top rails are made from high-strength alloy steel. For optimum durability and wear life, the ejector body is designed to work in applications where the material consists of rocks smaller than 152 mm (6 in) in diameter.

Blade

The ejector blade is made from high-strength steel and uses technology similar to that proven in Cat wheel tractor-scrappers.

Cylinder

A four-stage, high-speed, double-acting cylinder is specifically designed for horizontal mounting and smooth load ejection.



Serviceability

Maximize uptime and reduce costs

Long Service Intervals

Changes to oil change intervals, volumes and the type of oil required will help lower maintenance costs and machine downtime.

Lubrication Points

Lubrication points are grouped in the hitch area for ease of servicing. Universal joints are lubed for life, eliminating any maintenance. An autolube system is available as an option, and now includes alerts via Product Link for low grease levels.

Service Points

Mounted on the left side of the engine under the electrically raised hood:

- Engine dipstick and fill cap
- Transmission dipstick and fill cap
- Air, fuel water separator and fuel filters
- Electrically operated fuel-priming pump
- Coolant level indicator and fill cap are outside the cab

Radiator

The radiator package is located behind the cab, which provides protection from frontal impacts and offers easy access to the inlet and outlet sides of the radiator.

Extended Life Coolant

Extends the change interval and improves component life by reducing aluminum corrosion.

Electrical Service Center

Located inside the cab, this service center provides a power port, diagnostic connector and Cat Data Link connector.

Cat Data Link Connector

The Cat Data Link connector provides a plug-in using a laptop with Electronic Technician (ET) software.

Service Access

The cab tilts to the side to provide easy access underneath, which simplifies access to the transmission, drive shafts and hydraulic pumps. Machine electrical and hydraulic interfaces are located on the right side of the cab, behind a removable body panel for easy access.

Truck Transport

The suspension system eliminates the need to lower the suspension when transporting the truck, reducing maintenance and downtime.



Complete Customer Support

A commitment to your success

Selection

Make comparisons of the machines you are considering before you buy. Your Cat dealer can help.

Purchase

Consider the resale value; compare productivity and day-to-day operating costs and fuel consumption.

Operation

For the best operating techniques to increase productivity and your profit, turn to your Cat dealer for the latest training literature and trained staff.

Maintenance

Repair option programs guarantee the cost of repairs up front. Diagnostic programs such as S-O-SSM and Technical Analysis help you avoid unscheduled repairs.

Replacement

Repair or rebuild? Your Cat dealer can help you evaluate the costs so you can make the right choice.

Product Support

Your local Cat dealership will be with you every step of the way with its unsurpassed worldwide parts support, trained technicians and customer support agreements.

cat.com

For more complete information on Cat products, dealer services and industry solutions, visit us on the Web at www.cat.com.



Sustainability

Making sustainable progress possible

All Cat Articulated Trucks are designed to maximize efficiency and productivity while conserving natural resources.

Oil Volumes

The amount of both hydraulic and engine oil required has been lowered, reducing waste oil disposal.

Recycle Waste

The Caterpillar Design, Manufacturing, Assembly and Test Site at Peterlee in England recycle 98% of all waste produced with zero waste to landfill.

Second Life

Rebuild and reman are designed and built in to all Cat C Series Articulated Trucks. This gives machines a longer life while reducing waste and replacement costs.

Safety

Designed and built into every machine



Product Safety

Caterpillar has been and continues to be proactive in developing machines that meet or exceed safety standards. Safety is an integral part of all machines and system designs.

Safety Features

- Cab integral ROPS (Roll Over Protection System) and FOPS (Falling Object Protection System)
- Rearview camera system incorporate into the CMPD, can provide a continuous panoramic rear view or when reverse gear is selected
- The secondary and parking brake functions are spring applied and hydraulic released
- Electro-hydraulic secondary steering system automatically activates in forward/reverse or when stationary if low pressure is sensed. Can be manually selected for machine recovery purposes.
- Ground level external engine fuel cut off switch provides easy access outside of the machine
- External electrical system disconnect switch for easy access from outside of the machine
- Slip resistant walkways – punched steel plate
- 75 mm (3 in) wide seat belts for operator/trainer and passenger
- Wide angled mirrors for excellent rear visibility
- Sweeping hood design for panoramic forward visibility
- Extensive handrails
- Visual indicator for blade operation
- Heated mirrors (optional)
- LED-flashing beacon (optional)
- Additional mirrors
- Maximum speed limiter
- Multiple camera option
- Internal and external grab handles
- Fire extinguisher in-cab mounting point
- Reversing indicator
- Park brake switch safety lock

740C EJ Articulated Truck Specifications

Engine

Engine Model	Cat C18 ACERT	
Gross Power – SAE J1995	381 kW	511 hp
Net Power – SAE J1349	370 kW	496 hp
Net Power – ISO 14396	376 kW	504 hp
Bore	145 mm	5.7 in
Stroke	183 mm	7.2 in
Displacement	18.1 L	1,106 in ³

- The power ratings apply at rated speed of 1,700 rpm when tested under the conditions for the specified standard.
- The net power advertised is the power available at the flywheel when the engine is equipped with alternator, air cleaner, muffler and fan at minimum speed.
- Net power when the fan is at maximum speed is 348 kW (467 hp) per the SAE reference conditions.
- The 740C EJ meets Tier 2/Stage II emission equivalent specifications for the U.S. and Europe.

No Engine De-rating Required Below	3050 m	10,000 ft
Peak Engine Torque Gross (SAE J1995)	2618 N·m	1,931 lbf-ft
Peak Engine Torque Net (SAE J1349)	2558 N·m	1,887 lbf-ft
Peak Engine Torque Speed	1,200 rpm	

Weights

Rated Payload	38 tonnes	42 tons
---------------	-----------	---------

Body Capacities

Heaped SAE 2:1	23 m ³	30.1 yd ³
Struck	18 m ³	23.5 yd ³

Transmission

Forward 1	6.1 km/h	3.8 mph
Forward 2	8.1 km/h	5 mph
Forward 3	11.2 km/h	7 mph
Forward 4	14.1 km/h	8.8 mph
Forward 5	18.7 km/h	11.6 mph
Forward 6	22.9 km/h	14.2 mph
Forward 7	31.5 km/h	19.6 mph
Forward 8	37.9 km/h	23.5 mph
Forward 9	54.8 km/h	34 mph
Reverse 1	6.4 km/h	4 mph
Reverse 2	14.6 km/h	9.1 mph

Sound Levels

Interior Cab	79 dB(A)
--------------	----------

- The operator sound exposure Leq (equivalent sound pressure level) measured according to the work cycle procedures specified in ANSI/SAE J1166 OCT98 is 76 dB(A), for the cab offered by Caterpillar, when properly installed and maintained and tested with the doors and windows closed.
- Hearing protection may be needed when operating with an open operator station and cab (when not properly maintained or doors/windows open) for extended periods or in noisy environments.

740C EJ Articulated Truck Specifications

Operating Weights

Front Axle – Empty	19 880 kg	43,828 lb
Center Axle – Empty	7950 kg	17,527 lb
Rear Axle – Empty	7710 kg	16,998 lb
Total – Empty	35 540 kg	78,352 lb
Front Axle – Rated Load	1600 kg	3,527 lb
Center Axle – Rated Load	18 200 kg	40,124 lb
Rear Axle – Rated Load	18 200 kg	40,124 lb
Total – Rated Load	38 000 kg	83,776 lb
Front Axle – Loaded	21 480 kg	47,355 lb
Center Axle – Loaded	26 150 kg	57,651 lb
Rear Axle – Loaded	25 910 kg	57,122 lb
Total – Loaded	73 540 kg	162,128 lb

Body Plate

High strength Brinell HB450 wear resistant steel

Service Refill Capacities

Fuel Tank	550 L	145.3 gal
Cooling System	90 L	23.7 gal
Brake Cooling Tank	67 L	17.69 gal
Steering/Hoist Hydraulic System	140 L	36.9 gal
Engine Crankcase	52 L	13.7 gal
Transmission/OTG	75 L	19.8 gal
Final Drives (each)	5 L	1.3 gal
Axles (each)	60 L	15.8 gal

Body Hoist

Eject Time	17 Seconds
Retract Time	20 Seconds

Standards

Brakes	ISO 3450-2011
Cab/FOPS	ISO 3449 Level II-2005
Cab/ROPS	ISO 3471-2008
Steering	ISO 5010-2007

740C EJ Articulated Truck Specifications

Dimensions

All dimensions are approximate.

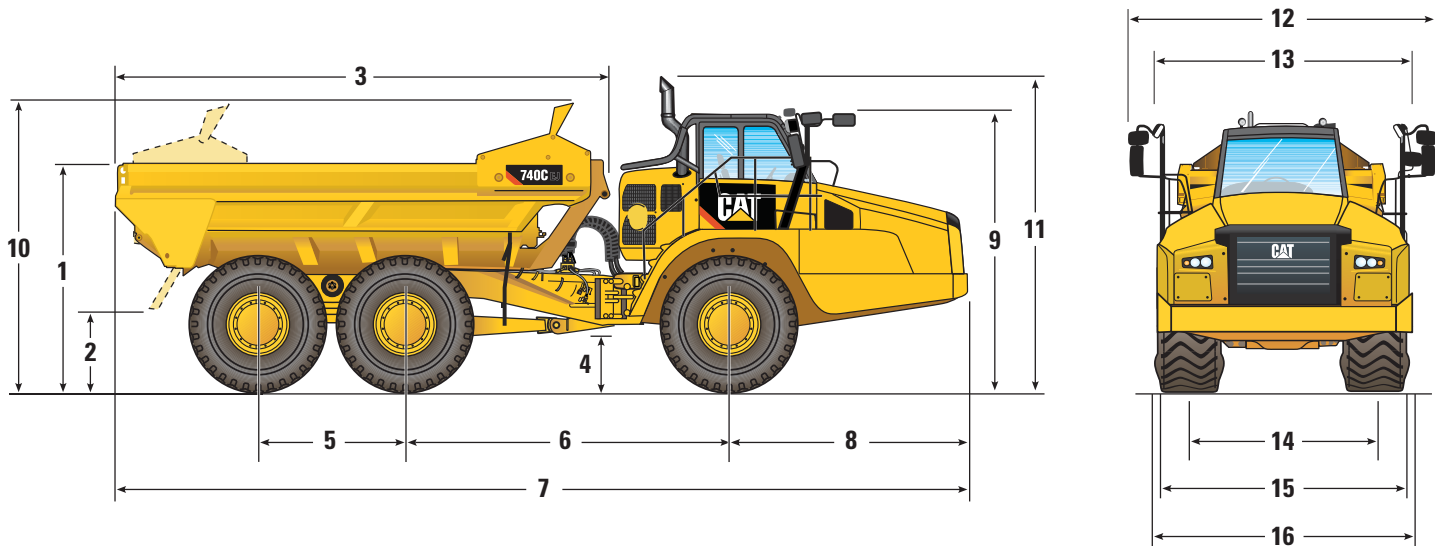

	mm	ft/in		mm	ft/in
1	3076	10'1"	9	3746	12'3"
2	1107	3'7"	10	3966	13'0"
3	6761	22'2"	11	4041	13'3"
4	579	1'10"	12	4166	13'8"
5	1966	6'5"	13**	3522	11'6"
6	4590	15'0"	14***	2687	8'9"
7*	11 776	38'7"	15†	3370	11'0"
8	3415	11'2"	16††	3530	11'6"

- * OAL
- ** Body Width
- *** Track Width
- † Over Fenders
- †† Over Tire Bulge

Unladen dimensions with 29.5R25 standard tires.

740C EJ Articulated Truck Specifications

Turning Circle

Dimensions are for machines equipped with 29.5R25 tires.

Turning Dimensions

Steer Angle – Left/Right	45°	
SAE Turning Radius	8624 mm	340 in
Clearance Radius	9082 mm	358 in
Inside Radius	4413 mm	174 in
Aisle Width	5961 mm	235 in

Steering

Lock to Lock

4.8 seconds @ 60 rpm

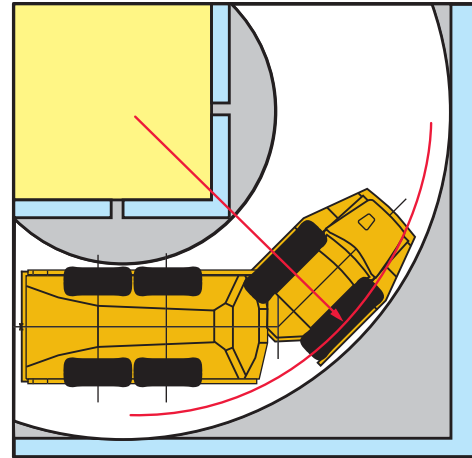

Optimal Loader/Truck Pass Matching

Hydraulic Excavators	390F	374F	349E
Passes	3-4	4-5	5-6
Wheel Loaders	980M	972M	966M
Passes	5	5-6	6

An optimum system match gives you a major productivity advantage. The 740C EJ is an excellent match for the Cat 390F, 374F and 349E Hydraulic Excavators; and Cat 966M, 972M, and 980M Wheel Loaders. Having matched loading and hauling tools results in increased production and lower system costs per unit of volume moved.

740C EJ Articulated Truck Specifications

Gradeability/Speed/Rimpull

To determine performance, read from Gross Weight down to % Total Resistance. Total Resistance equals actual % grade plus 1% for each 10 kg/metric ton (20 lb/ton) of Rolling Resistance. From this point, read horizontally to the curve with the highest attainable speed range. Then, go down to Maximum Speed. Usable Rimpull depends on traction available.

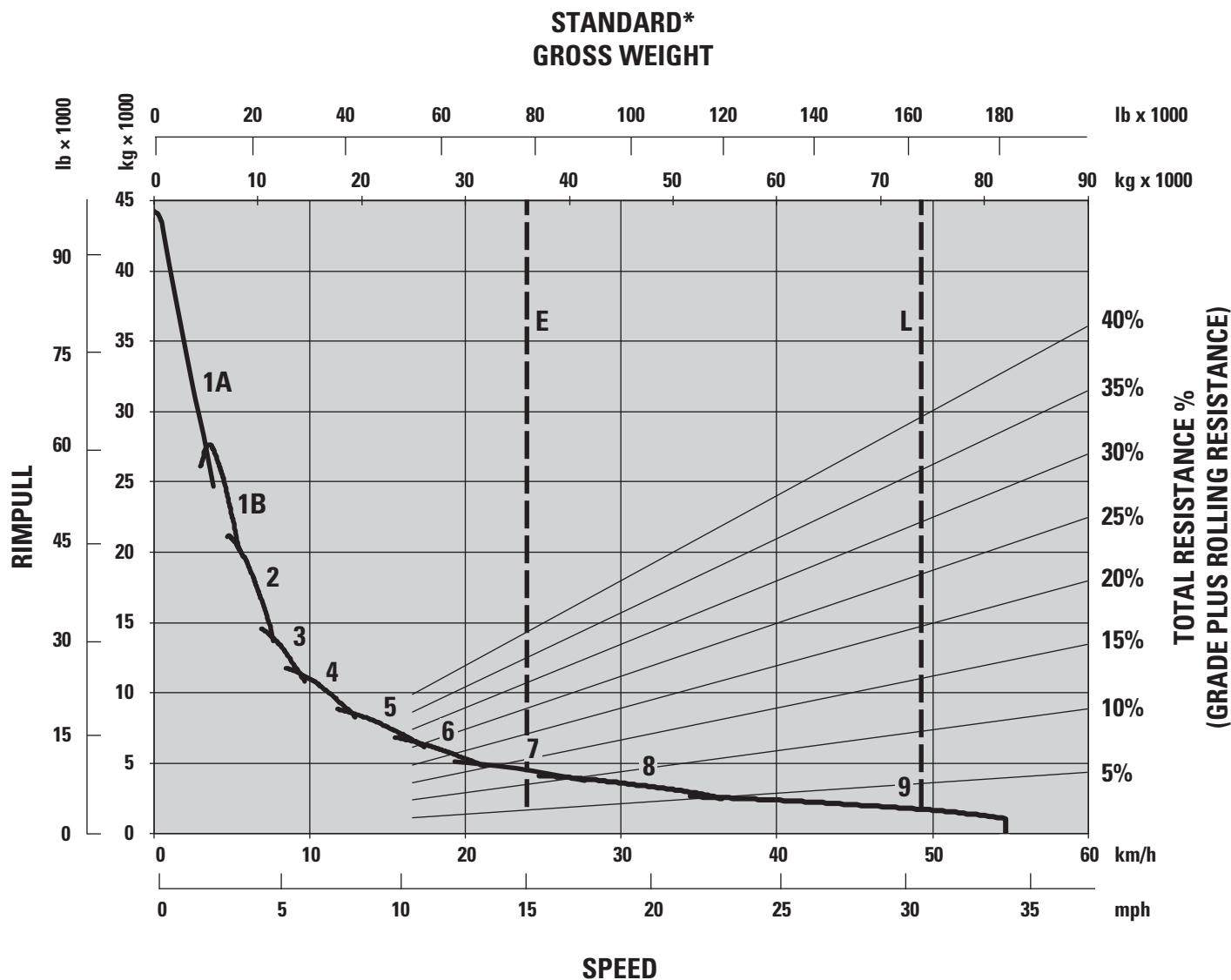

- 1A – 1st Gear (Converter Drive)
- 1B – 1st Gear (Direct Drive)
- 2 – 2nd Gear
- 3 – 3rd Gear
- 4 – 4th Gear
- 5 – 5th Gear
- 6 – 6th Gear
- 7 – 7th Gear
- 8 – 8th Gear
- 9 – 9th Gear

- E – Empty 35 540 kg (78,352 lb)
- L – Loaded 73 540 kg (162,128 lb)
- * at sea level

740C EJ Articulated Truck Specifications

Retarding Performance

To determine performance, read from Gross Weight down to % Effective Grade. Effective Grade equals actual % favorable grade plus 1% for each 10 kg/metric ton (20 lb/ton) of Rolling Resistance. From this point, read horizontally to the curve with the highest attainable speed range. Then, go down to Maximum Speed. Retarding effect on these curves represents full application of the retarder.

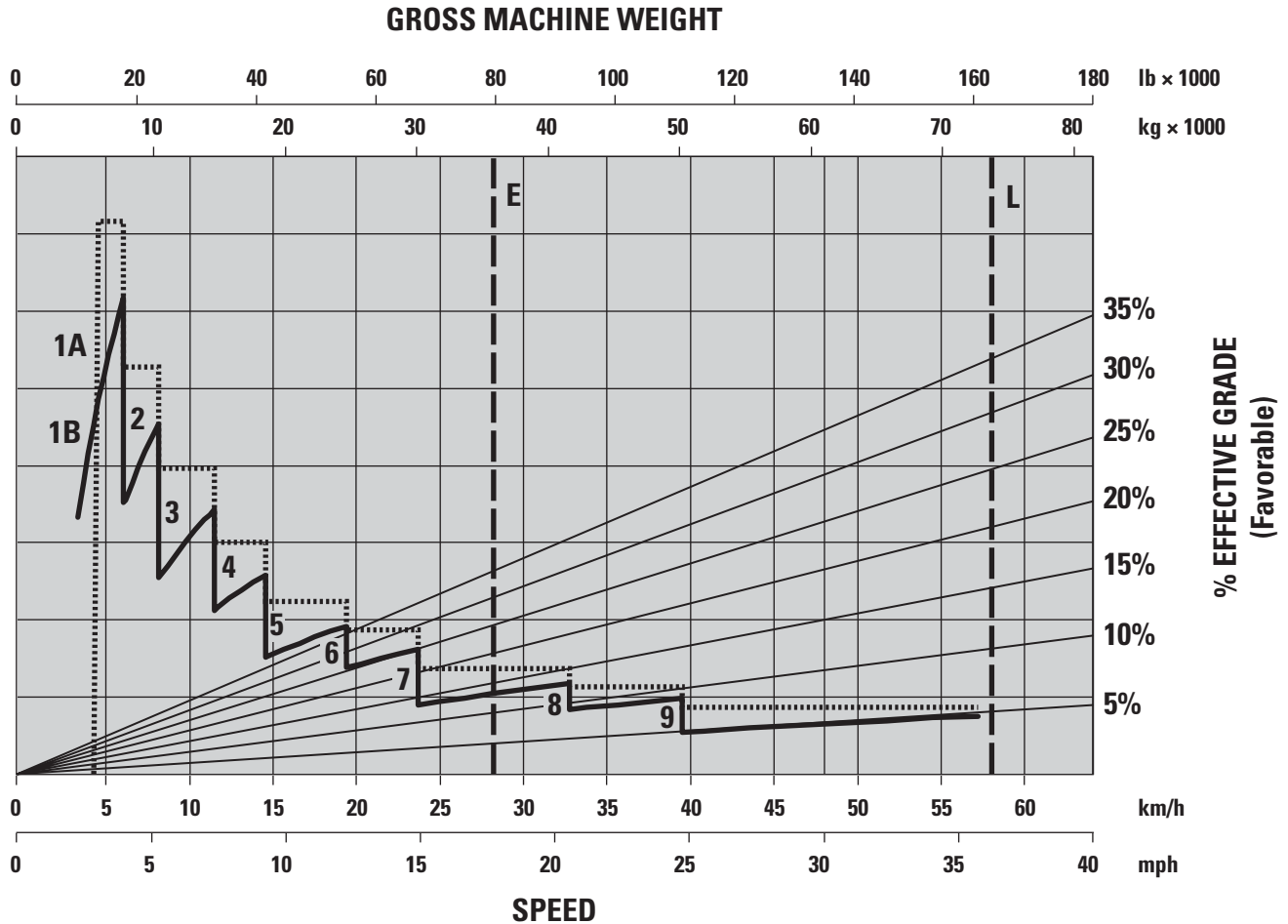

- 1A – 1st Gear (Converter Drive)
- 1B – 1st Gear (Direct Drive)
- 2 – 2nd Gear
- 3 – 3rd Gear
- 4 – 4th Gear
- 5 – 5th Gear
- 6 – 6th Gear
- 7 – 7th Gear
- 8 – 8th Gear
- 9 – 9th Gear

- E – Empty 35 540 kg (78,352 lb)
- L – Loaded 73 540 kg (162,128 lb)
- * at sea level

Standard Equipment

Standard equipment may vary. Consult your Cat dealer for details.

- Air conditioning with R134A refrigerant
- Adjustable air vents
- Auto shift nine-speed forward and two reverse transmission
- Reverse alarm
- Cat C18 ACERT engine
- Cat rearview camera
- Color Multi-Purpose Display (CMPD) incorporating the rearview camera feed
- Differentials: standard with automatic clutched inter and cross-axle differential locks
- Dual circuit oil immersed, enclosed brakes – all wheels
- Electrical system: 24 volt, 5A 24- to 12-volt converter
- Electro hydraulic hoist control
- Glass windows: laminated and tinted-front toughened and tinted-sides and rear
- Guards: rear window, radiator, crankcase and axle
- Heater and defroster with four-speed fan
- Horn: electric
- Lights: cab interior, front, width marker, side, rear, two reversing/work light, two stop/tail lights, front and rear direction indicators
- Mirrors: extensive arrangement for improved visibility
- Mud flaps: wheel arch and body mounted with transportation tiebacks
- Product Link: PL321 or PL522 dependent on location and licensing agreement
- Retarder: engine compression brake
- ROPS/FOPS cab, Machine Operation Monitoring System includes
 - Action lamp, engine oil pressure, primary steering system, left turn signal, high beam, coolant temperature, tachometer, parking brake, fuel level, right turn signal, transmission oil temperature, brake system, transmission hold, eject control, hydraulic system, charging system, retarder, transmission fault, traction control system, check engine lamp
- Liquid Crystal Display (LCD)
 - Alert indicator, selected gear and direction, speed or auto shift, review Operation and Maintenance Manual (OMM), primary steering failure, seat belt warning, secondary steering failure, Machine Security System (MSS), secondary steering energy source engaged, hour meter and retarder active
- Seat, fully adjustable, air suspension
- Seat, padded companion/trainer
- Secondary steering – electro hydraulic
- S·O·S sampling valves
- Spill guard, front, integral part of fabricated body
- Starting receptacle, electric, remote
- Storage: cup holder, flask receptacle, under seat storage, door pocket, behind seat storage, coat hook
- Sun visor
- Hydraulic tailgate
- Three axle, six-wheel drive
- Tilt and telescopic steering wheel
- Tires, six 29.5R25, radial
- Two seat belts, operator's retractable
- Vandalism protection: lockable caps for fuel tank and hydraulic oil tank
- Windows opening side, tinted
- Windshield wiper and washer, two speed, intermittent (front)
- Windshield wiper and washer, two speed (rear)

740C EJ Optional Equipment

Optional Equipment

Optional equipment may vary. Consult your Cat dealer for details.

- Auto lube installation for automatic greasing of bearings
- Body liners
- Bluetooth radio stereo system
- Cold weather coolant -51°C (-60°F)
- Cold weather start attachment
- Engine block heater
- Ether start
- Exhaust heated body
- Fast fuel fill
- Flashing LED beacon
- Fuel additive-anti-waxing
- Heated seat
- Heated rearview motorized mirrors
- Machine Security System (MSS)
- Product Link: PL321, PL522, VIMS™ Cellular, VIMS Satellite (where available)
- Roof mounted High Intensity Discharge (HID) work lights
- 875/65 R29 wide tires
- Cat production measurement payload monitoring system

For more complete information on Cat products, dealer services, and industry solutions, visit us on the web at www.cat.com

AEHQ7412 (02-2015)

© 2015 Caterpillar
All rights reserved

Materials and specifications are subject to change without notice. Featured machines in photos may include additional equipment. See your Cat dealer for available options.

CAT, CATERPILLAR, SAFETY.CAT.COM, their respective logos, "Caterpillar Yellow" and the "Power Edge" trade dress, as well as corporate and product identity used herein, are trademarks of Caterpillar and may not be used without permission.

VisionLink is a trademark of Trimble Navigation Limited, registered in the United States and in other countries.

