

400 Series 402D-05 Industrial

10.2 kW / 13.7 hp @ 3600 rpm

The Perkins® 400D range has been developed in consultation with our marketplace. This 0.5 litre, 2 cylinder engine is the smallest engine offered by Perkins, however, this ultra-compact, lightweight power unit still maintains all the customer benefits experienced from this exciting product range.

The 400 Series engine family continues to set new standards in the compact engine market. Developed alongside customers to fulfil their needs in the construction, materials handling, agricultural/turf, genset and compressor markets, it is another class leading diesel range from Perkins.

The 400D range of engines has been designed to fully comply with stringent EU emissions regulations, providing an emissions compliant power solution for the future.

Long 500 hour service intervals, a two-year standard warranty, low noise and harshness and a wide range of options make the 400 Series range the complete solution for compact power needs.

The 402D-05 is a 2 cylinder 0.5 litre unit which delivers impressive performance, with low operating costs in an ultra compact, efficient package ideally suited to a wide range of small off-highway applications.



Emissions statement

Industrial and IOPU Engines: Certified against the requirements of EU Stage IIIA (Directives 97/68/EC as last amended, and 2004/26/EC, as last amended).

Constant Speed engines for use in Industrial, IOPU and ElectropaK applications: Certified against the requirements of EU Stage IIIA (Directive 97/68/EC, as last amended) for mobile applications.

Specification		
Number of cylinders	2 in-line	
Bore and stroke	67 x 72 mm	2.6 x 2.8 in
Displacement	0.51 litres	31 in ³
Aspiration	Naturally aspirated	
Cycle	4 stroke	
Combustion system	Indirect injection	
Compression ratio	23.5:1	
Rotation	Counter-clockwise, viewed on flywheel	
Total lubricating capacity	2.01 litres	0.5 US gal
Cooling system	Liquid	
Total coolant capacity	1.1 litres	0.3 US gal

www.perkins.com

Photographs are for illustrative purposes only and may not reflect final specification.
All information in this document is substantially correct at time of printing and may be altered subsequently.
Final weight and dimensions will depend on completed specification.

Publication No. PN1812/12/14 Produced in England ©2014 Perkins Engines Company Limited

 **Perkins®**

THE HEART OF EVERY GREAT MACHINE

400 Series 402D-05 Industrial

10.2 kW / 13.7 hp @ 3600 rpm

Features and benefits

Ultra-compact power

- Up to 10.2 kW (13.7 bhp) from an engine envelope of 0.07 m³
- Easy installation even in the smallest of machines

Clean and quiet

- Noise levels have been kept to a minimum
- Subjective harshness has been carefully controlled making the engine sound even quieter

Durable power

- Product design and process improvements enhance both engine reliability and durability
- An improved (advanced) governor, valve seat inserts and new compliance testing deliver reliability of 6,000 hours
- A standard two-year warranty demonstrates our confidence in durability and reliability

Low operating costs

- Approved for operation on biodiesel* concentrations of up to 20%
- Oil and filter changes are 500 hours, dependent on load factor
- Engine durability and reliability, the warranty offering and ease of installation combine to drive down the cost of ownership
- **Warranties and Service Contracts**

We provide one-year warranties for constant speed engines and two-year warranties for variable speed models, as standard. These are supported by multilevel Extended Service Contracts that can be bought additionally
Discover more: www.perkins.esc

Product support

- With highly trained Perkins distributors in thousands of communities in over 180 countries, you are never far away from expert product knowledge, genuine parts and a range of advanced diagnostic technology for keeping your engine in peak condition
- To find your local distributor: www.perkins.com/distributor

*Subject to conformance with ASTM D6751 and EN14214

www.perkins.com

Photographs are for illustrative purposes only and may not reflect final specification.
All information in this document is substantially correct at time of printing and may be altered subsequently.
Final weight and dimensions will depend on completed specification.

Publication No. PN1812/12/14 Produced in England ©2014 Perkins Engines Company Limited

 **Perkins**[®]

THE HEART OF EVERY GREAT MACHINE

400 Series 402D-05 Industrial

10.2 kW / 13.7 hp @ 3600 rpm

Technical information

- Cast iron engine block
- Flywheel and flywheel housing
- Fuel injection pump
- Spin on fuel filter
- Glow plug starting aid
- Lub oil sump
- Spin on lub oil filter
- Inlet manifold
- Cast iron exhaust manifold – side outlet
- Closed circuit breather
- Coolant pump belt driven
- Starter motor 12 volt
- Alternator 12 volt 14 amp
- ESOS (Electric shut-off solenoid)
- Lub oil pressure switch
- Coolant temperature switch
- Choice of coolant fans
- Cold start capability to -20°C (aided)
- Gradeability 35° continuous

Option groups

A selection of optional items is available to enable you to prepare a specification precisely matched to your needs.

www.perkins.com

Photographs are for illustrative purposes only and may not reflect final specification.
All information in this document is substantially correct at time of printing and may be altered subsequently.
Final weight and dimensions will depend on completed specification.

Publication No. PN1812/12/14 Produced in England ©2014 Perkins Engines Company Limited

 **Perkins**[®]

THE HEART OF EVERY GREAT MACHINE

400 Series 402D-05 Industrial

10.2 kW / 13.7 hp @ 3600 rpm

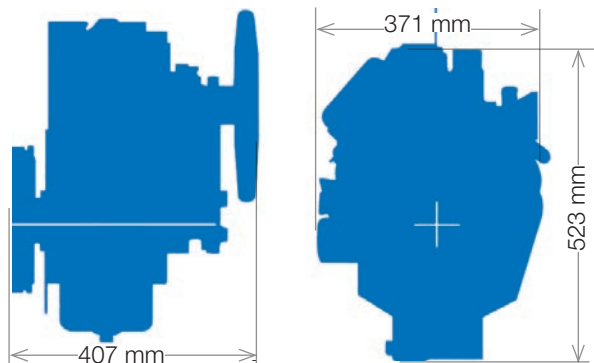

Engine package weights and dimensions

Engine package weights and dimensions		
Length	407 mm	16.0 in
Width	371 mm	14.6 in
Height	523 mm	20.6 in
Weight (dry)	57 kg	126 lb

www.perkins.com

Photographs are for illustrative purposes only and may not reflect final specification.
All information in this document is substantially correct at time of printing and may be altered subsequently.
Final weight and dimensions will depend on completed specification.

Publication No. PN1812/12/14 Produced in England ©2014 Perkins Engines Company Limited

 **Perkins**[®]

THE HEART OF EVERY GREAT MACHINE

400 Series 402D-05 Industrial

10.2 kW / 13.7 hp @ 3600 rpm

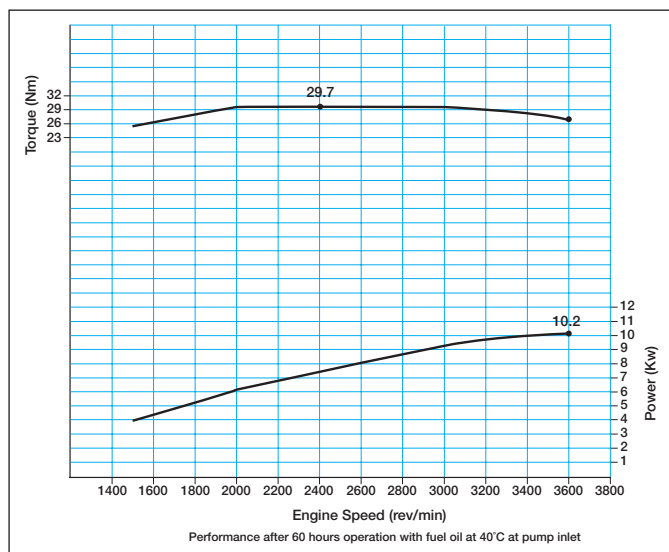

Performance data	Gross intermittent (ISO/TR 14396)	Speed rpm
Power output (kW)	10.2	3600
Power output (hp)	13.7	3600
Peak torque (Nm)	29.7	2400
Peak torque (lbf-ft)	21.9	2400

Power output for a run-in engine after 60 hours

www.perkins.com

Photographs are for illustrative purposes only and may not reflect final specification. All information in this document is substantially correct at time of printing and may be altered subsequently. Final weight and dimensions will depend on completed specification.

Publication No. PN1812/12/14 Produced in England ©2014 Perkins Engines Company Limited

 **Perkins**[®]

THE HEART OF EVERY GREAT MACHINE