

1200 Series 1206F-E70TA Industrial Engine

EU Stage IV and EPA Tier 4 Final
116-151 kW / 156-202 hp

The addition of the 1206F range to our 1200 Series ensures our customers have a complete power solution ready and available when they need to change over to the next stage of emissions legislation – EU Stage IV, Tier 4 Final in 2014. They offer not only specific power outputs but also a choice of engine configurations and options. Their robust technology allows our OEMs the ability to integrate these engines into their equipment with the minimum of re-engineering.

The 1206F range is available as single turbocharged and series turbocharged, air-to-air charge cooled, 7 litre, 6 cylinder units capable of producing 225 kW (301.8 hp). Their high power density, combined with excellent torque, enables the machine manufacturers to select this engine where previously they may have used an engine of a higher cubic capacity. This downsizing represents a cost saving and creates more space to package the new aftertreatment units.

The Perkins® 1200 Series engines have the innovative design to meet the latest, stringent emissions legislation; the flexibility to integrate into more than 800 different types of equipment.

Perkins have developed a reputation for designing and building reliable and durable engines suitable for the most demanding applications.



Emissions

Designed to meet 2014 EU Stage IV (Europe), EPA Tier 4 Final (US) and MLIT 2014 Regulations (Japan).

Specification		
Number of cylinders	6 vertical in-line	
Bore and stroke	105 x 135 mm	4.13 x 5.3 in
Displacement	7.01 litres	427.7 in ³
Aspiration	Turbocharged aftercooled	
Cycle	4 stroke	
Combustion system	Direct injection	
Compression ratio	16.5:1	
Rotation	Anti-clockwise, viewed on flywheel	
Total lubricating capacity	13-16 litres	3.4-4.2 US gal
Cooling system	Liquid	
Total coolant capacity	15.2 litres	4 US gal

www.perkins.com

Photographs are for illustrative purposes only and may not reflect final specification.
All information in this document is substantially correct at time of printing and may be altered subsequently.
Final weight and dimensions will depend on completed specification.

Publication No. PN2011A/12/14 Produced in England ©2014 Perkins Engines Company Limited

 **Perkins®**

THE HEART OF EVERY GREAT MACHINE

1200 Series 1206F-E70TA Industrial Engine

EU Stage IV and EPA Tier 4 Final
116-151 kW / 156-202 hp

Features and benefits

Dependable power

- World-class manufacturing capability and processes coupled with proven core engine designs assure reliability, quiet operation, and many hours of productive life

Lifetime of low cost

- Fuel consumption optimised to match operating cycles of a wide range of equipment and applications
- Hydraulic tappets, multi-vee belts, service-free aftertreatment and 500 hour oil change intervals enable low-cost maintenance. Many service items have a choice of location on either side of the engine to enable choice of service access
- Extended Service Contracts – protect and plan the cost of ownership
Discover more: www.perkins.com/esc

Industry leading flexibility

- Exceptional power density enables standardisation across numerous applications. Multiple installation options minimise total package size. Ideal for equipment with narrow engine compartments

Local support, global coverage

- Perkins recognise that the customer relationship is important to machine manufacturers and we can offer a range of flexible solutions to help provide appropriate support, either to the OEM's network or directly to the machine customer
- Perkins information systems enable our distributors to quickly diagnose engine faults and identify the right parts. The Perkins logistics operation is able to dispatch more than 45,000 different parts from stock, reaching the customer within 24 hours
- To find your local distributor: www.perkins.com/distributor

www.perkins.com

Photographs are for illustrative purposes only and may not reflect final specification.
All information in this document is substantially correct at time of printing and may be altered subsequently.
Final weight and dimensions will depend on completed specification.

Publication No. PN2011A/12/14 Produced in England ©2014 Perkins Engines Company Limited

 **Perkins**[®]

THE HEART OF EVERY GREAT MACHINE

1200 Series 1206F-E70TA Industrial Engine

EU Stage IV and EPA Tier 4 Final
116-151 kW / 156-202 hp

Technical information

Air inlet

- Standard air cleaners

Control system

- Full electronic control system
- All connectors and wiring looms waterproof and designed to withstand harsh off-highway environments
- Flexible and configurable software features and well supported SAE J1939 CAN bus enables highly integrated machines

Cooling system

- Top tank temperature 108°C as standard to minimise cooling pack size
- 50:50 water glycol mix
- Detailed guidance on cooling system design and validation available to ensure machine reliability

Standard emissions control equipment

- NRS – NOx Reduction System

Flywheels and flywheel housing

- Wide choice of drivetrain interfaces, SAE1, SAE2 and SAE3 configurations

Fuel and fuel system

- Industrial technology requires Ultra Low Sulphur Diesel Fuel (ULSD, 15 ppm sulphur), in addition to ultra low sulphur diesel oils, for use in Tier 4 Interim/Stage IIIB engines. These cleaner fuels and oils will help reduce ash and maintain service intervals. In addition, B20 biodiesel capability adds even greater sustainability where desired or required
- Electronic high pressure common rail
- Innovative filter design – ensures maximum protection of the engine

Oil system

- Choice of sumps for different applications

Power take-off

- SAE A or SAE B flanges on left-hand side. Right hand side twin PTO also available. Engine power can also be taken from the front of the engine on some applications
- Factory fitted compressors are also available

www.perkins.com

Photographs are for illustrative purposes only and may not reflect final specification.
All information in this document is substantially correct at time of printing and may be altered subsequently.
Final weight and dimensions will depend on completed specification.

Publication No. PN2011A/12/14 Produced in England ©2014 Perkins Engines Company Limited

 **Perkins**[®]

THE HEART OF EVERY GREAT MACHINE

1200 Series 1206F-E70TA Industrial Engine

EU Stage IV and EPA Tier 4 Final
116-151 kW / 156-202 hp

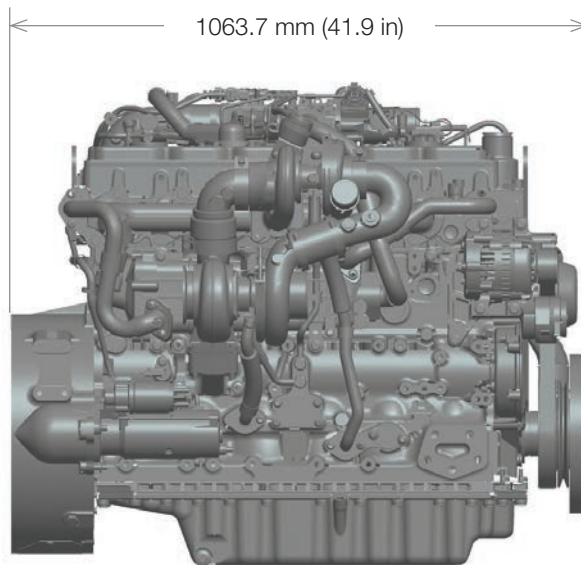
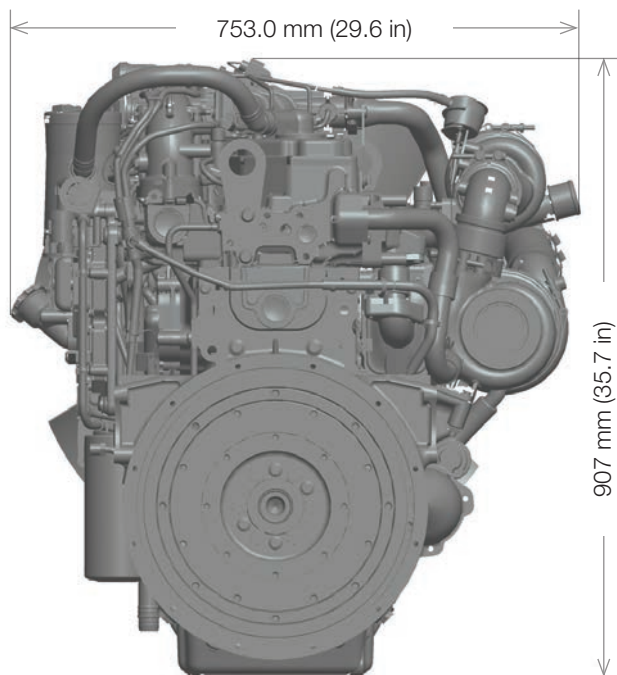

Engine package weights and dimensions (includes electrics and backend)

Length	1063.7 mm	41.9 in
Width	753.0 mm	29.6 in
Height	907 mm	35.7 in
Weight (dry)	715 kg	1576 lb

www.perkins.com

Photographs are for illustrative purposes only and may not reflect final specification.
All information in this document is substantially correct at time of printing and may be altered subsequently.
Final weight and dimensions will depend on completed specification.

Publication No. PN2011A/12/14 Produced in England ©2014 Perkins Engines Company Limited

 **Perkins**[®]

THE HEART OF EVERY GREAT MACHINE

1200 Series 1206F-E70TA Industrial Engine

EU Stage IV and EPA Tier 4 Final
116-151 kW / 156-202 hp

Front view

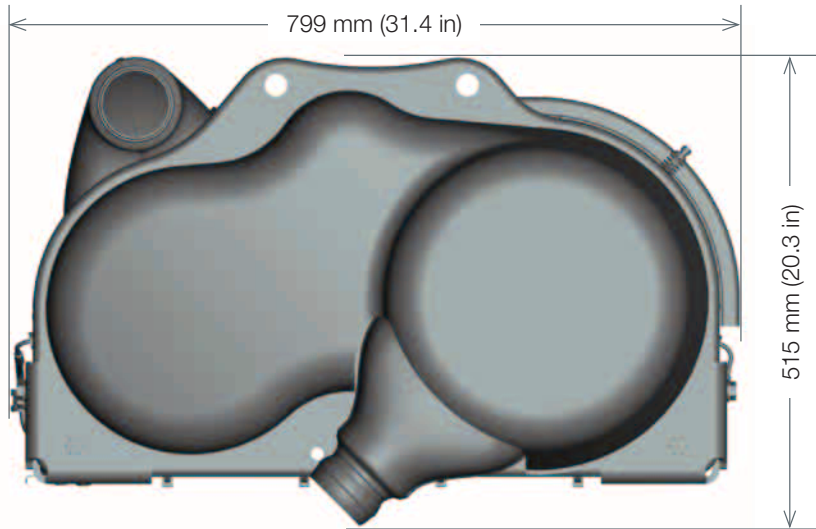

Top view

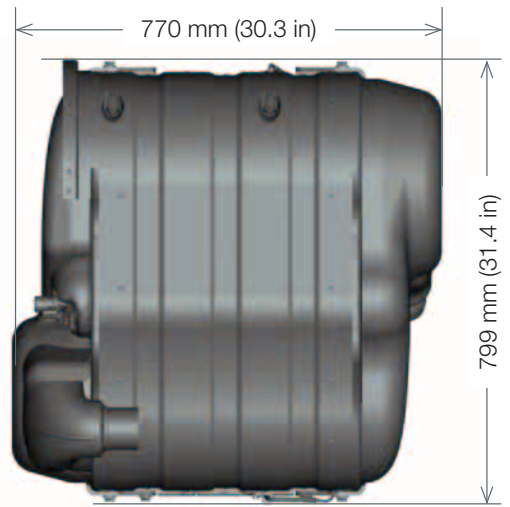

Aftertreatment weights and dimensions		
Length	799 mm	31.4 in
Width	770 mm	30.3 in
Height	515 mm	20.3 in

Aftertreatment

- CEM – Clean Emissions Module
- Basic aftertreatment package includes DOC / DPF / SCR
- DOC – Diesel Oxidation Catalyst
- DPF – Diesel Particulate Filter
- SCR – Selective Catalytic Reduction
- 3 inch flex pipe connection kit with rotatable elbow for 60° and 90° RS inlet flexibility

Technology

The DPF technology chosen is a wall flow filter configuration. This enables the engine to be optimised for superior performance and low fuel consumption.

Power

Using our advanced research and development techniques, we have perfectly matched the aftertreatment to the engine. The engine performance has then been optimised to give the maximum power and in normal operation, the regeneration is invisible to the operator.

Regeneration

Passive Regenerations System maximises fuel efficiency during regeneration.

Mounting

Remote and engine-mounted installation options provide OEM flexibility for many applications.

Service

Aftertreatment designed to be service-free.

www.perkins.com

Photographs are for illustrative purposes only and may not reflect final specification. All information in this document is substantially correct at time of printing and may be altered subsequently. Final weight and dimensions will depend on completed specification.

Publication No. PN2011A/12/14 Produced in England ©2014 Perkins Engines Company Limited

 **Perkins**[®]

THE HEART OF EVERY GREAT MACHINE

1200 Series 1206F-E70TA Industrial Engine

EU Stage IV and EPA Tier 4 Final
116-151 kW / 156-202 hp

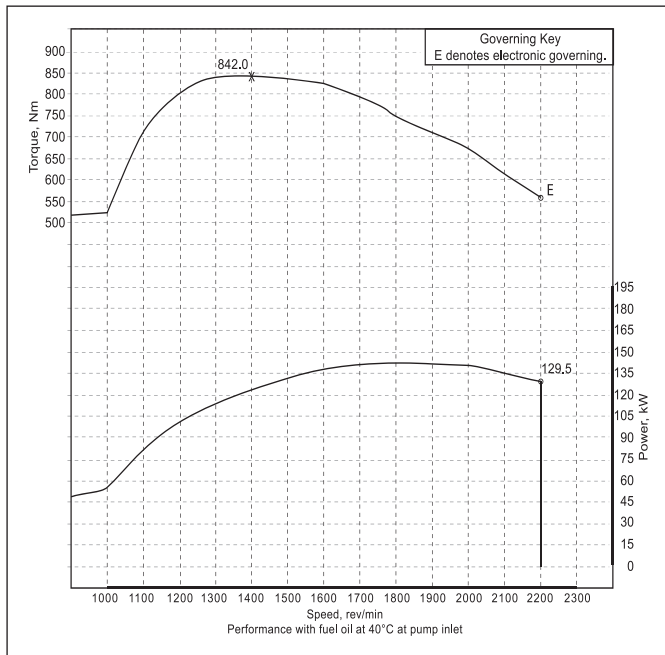

Speed rpm	Power kW	Power hp	Speed rpm	Torque Nm	Torque lbf-ft	Rating type
2200	116	156	1400	755	557	B
2200	*129	173	1400	842	621	B
2200	151	202	1400	870	642	C

*Curve shown

Rating Standard ISO 14396:2002

Unless otherwise specified, all stated data is for maximum rated speed and 100% load

Rating definitions and conditions

IND-B for service where power and/or speed are cyclic (time at full load not to exceed 80%).

IND-C (Intermittent) is the horsepower and speed capability of the engine where maximum power and/or speed are cyclic (time at full load not to exceed 50%).

Additional ratings are available for specific customer requirements. Consult your Perkins distributor.

Rating Conditions for Diesel Engines – up to 7.1 litres are based on ISO/TR14396, inlet air standard conditions with a total barometric pressure of 100 kPa (29.5 in. Hg), with a vapour pressure of 1 kPa (0.295 in Hg) and 25°C (77°F). Performance is measured using fuel to specification EPA 2D 89.330-96 with a density of 0.845-0.850 kg/L @ 15°C (59°F) and fuel inlet temperature 40°C (104°F).

www.perkins.com

Photographs are for illustrative purposes only and may not reflect final specification.
All information in this document is substantially correct at time of printing and may be altered subsequently.
Final weight and dimensions will depend on completed specification.

Publication No. PN2011A/12/14 Produced in England ©2014 Perkins Engines Company Limited

 **Perkins**[®]

THE HEART OF EVERY GREAT MACHINE