

Perkins Sabre 4.4TGM Radiator Cooled, Auxiliary Marine Diesel Engine

CATERPILLAR MARINE POWER UK LTD
 Wimborne, Dorset, England.
 Tel. +44(0)1202 893720
 Fax. +44(0)1202 851700
 E-mail. Wimborne_MPC_post@cat.com
www.Perkins-Sabre.com

Total dry weight = 511kg

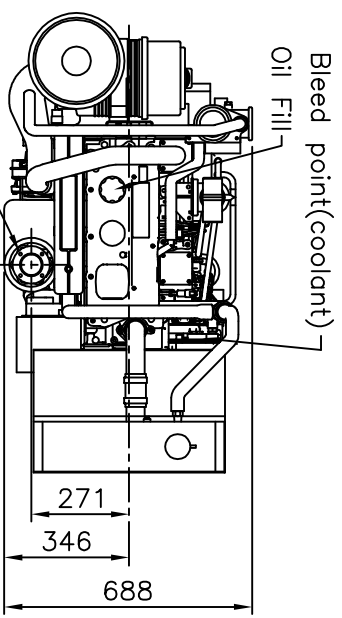

Exhaust Outlet
 4 x Ø8.5 holes
 equispaced on
 a 85.0 PCD,
 Flange Ø104.

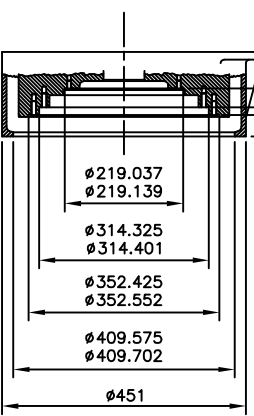
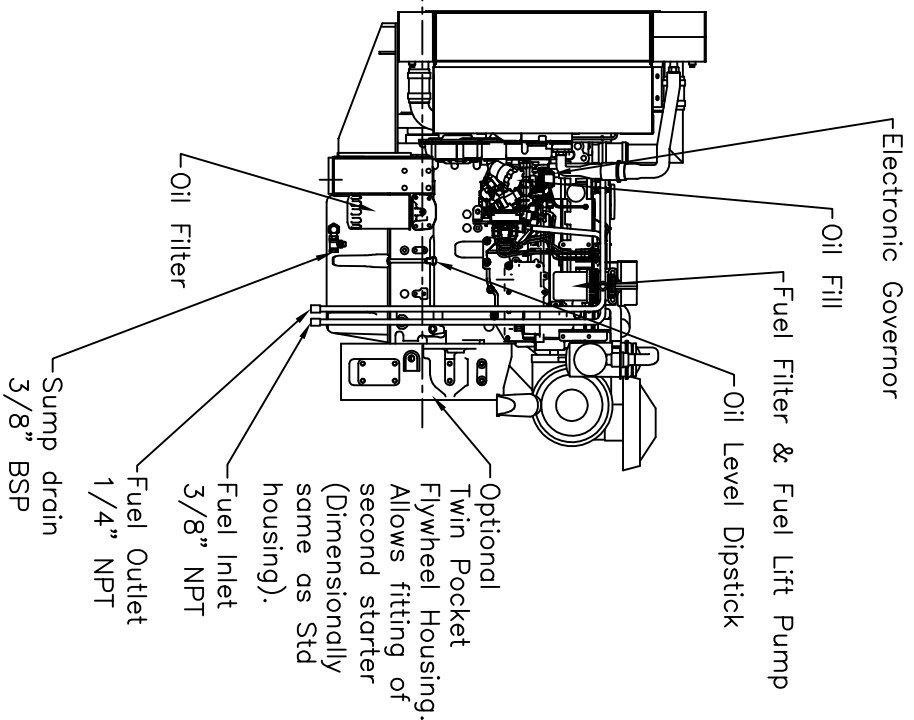
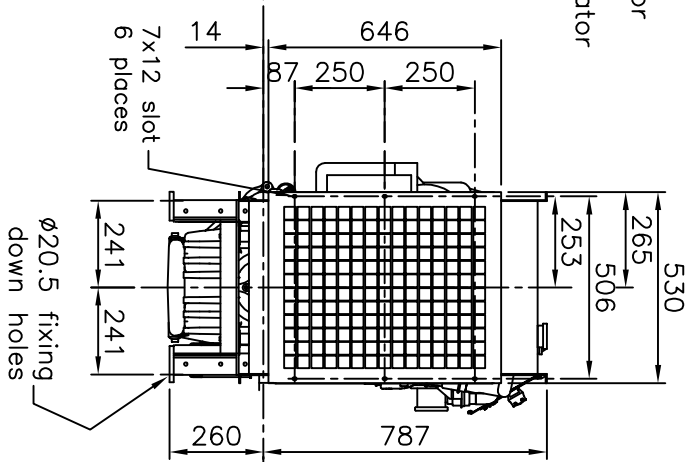
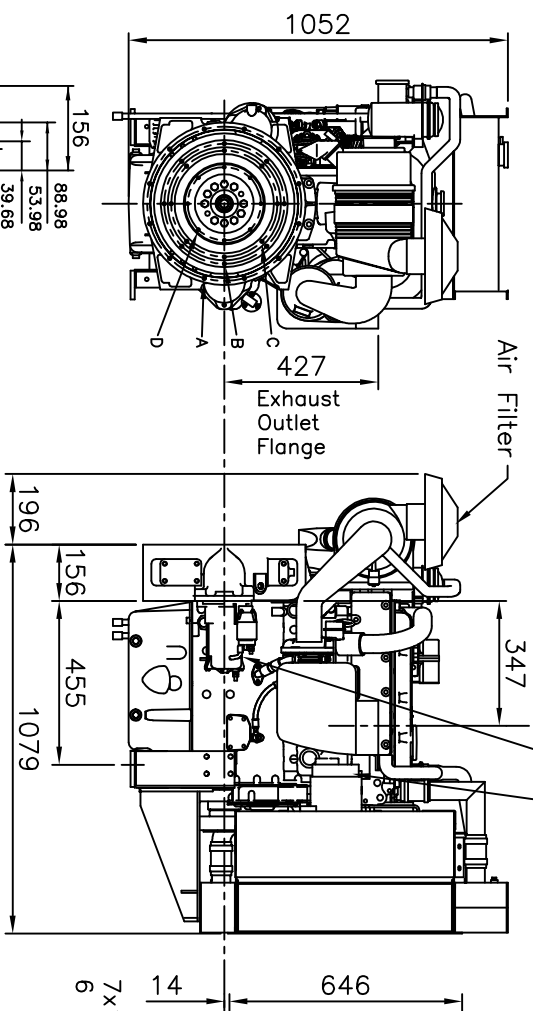

- SAE3 Housing Hole Details:
 A. 12 Holes M10 x 1.5 x 20
 equi-spaced on a 428.63 PCD.
 Flywheel Hole Details:
 B. 8 Holes 3/8" x 24 UNF x 25.4
 equi-spaced on a 333.36 PCD.
 C. 8 Holes 3/8" x 24 UNF x 25.4
 equi-spaced on a 295.28 PCD.
 D. 8 Holes M8 x 1.25 x 14.3
 equi-spaced on a 203.20 PCD.

Section through SAE3 housing and flywheel - scale 2:3

Rev 3 - Exhaust height added, oil fill clarified, SAE3 section was 1:1 - GM - 20.3.07
 Rev 2 - Sump drain added - GM - 9.10.06