

Perkins M300C & M250C Marine Diesel Engine  
 Shown with ZF85A gearbox with reduction ratios up to  
 and including 2.5:1 ratios (622 mm transverse mounting centres)

WIMBORNE MARINE POWER CENTRE  
 Wimborne, Dorset, England.  
 Tel. +44(0)1202 893720  
 Fax. +44(0)1202 851700  
 E-mail. [Wimborne\\_MPC\\_post@cat.com](mailto:Wimborne_MPC_post@cat.com)  
[www.Perkins-Sabre.com](http://www.Perkins-Sabre.com)

Total Dry Weight: 773kg

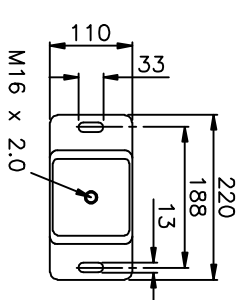
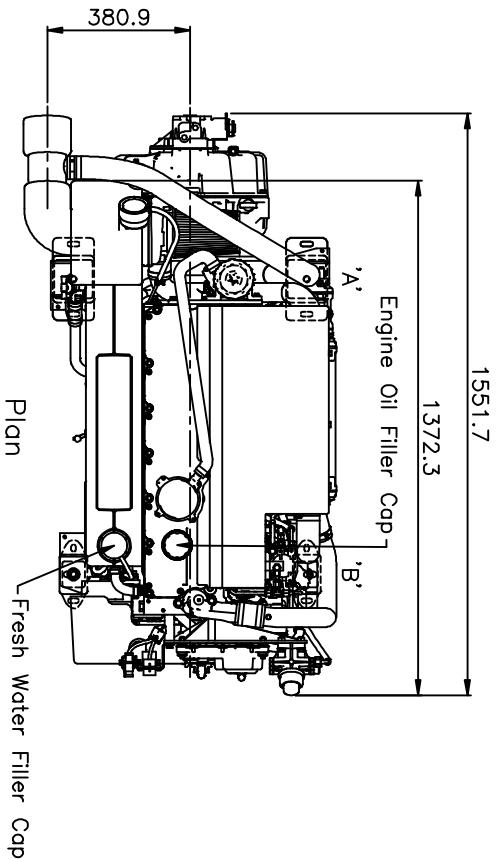

FLEXIBLE ENGINE MOUNT 'A'

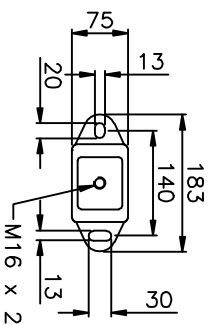

FLEXIBLE ENGINE MOUNT 'B'

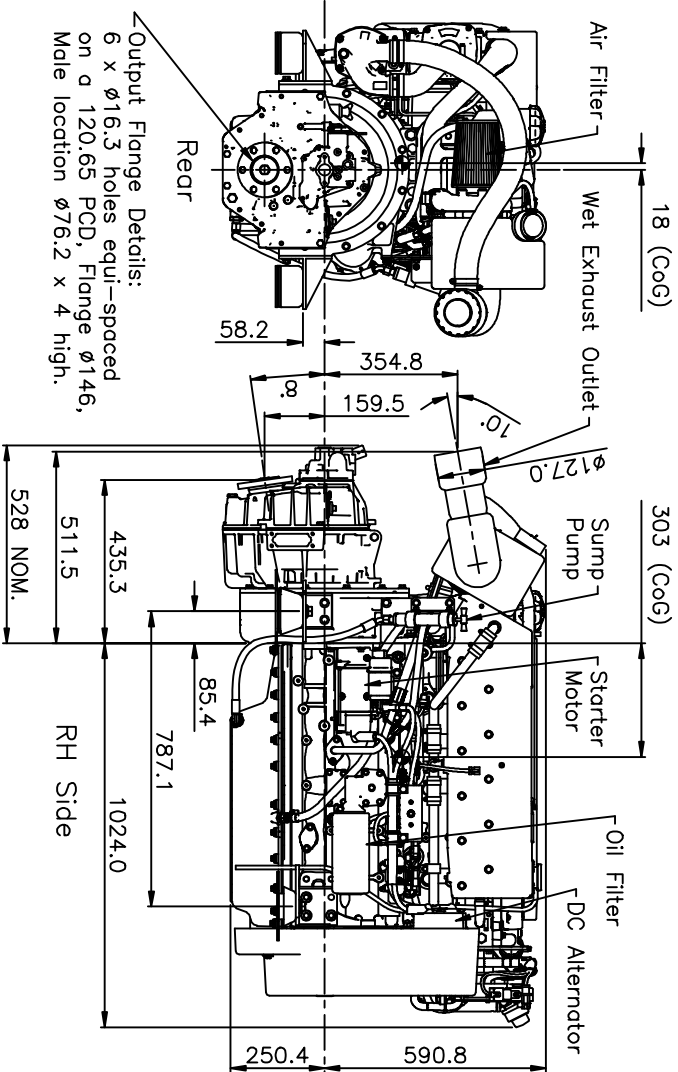

Output Flange Details:  
 6 x  $\phi 16.3$  holes equi-spaced  
 on a 120.65 PCD, Flange  $\phi 146$ ,  
 Male location  $\phi 76.2$  x 4 high.

