

Perkins M216C & M190C Marine Diesel Engine
 Shown with ZF220A gearbox with reduction ratios up to
 and including 2.04:1 ratios (622 mm transverse mounting centres)

WIMBORNE MARINE POWER CENTRE
 Wimborne, Dorset, England.
 Tel. +44(0)1202 893720
 Fax. +44(0)1202 851700
 E-mail. Wimborne_MPC_post@cat.com
www.Perkins-Sabre.com

Total Dry Weight: 752kg

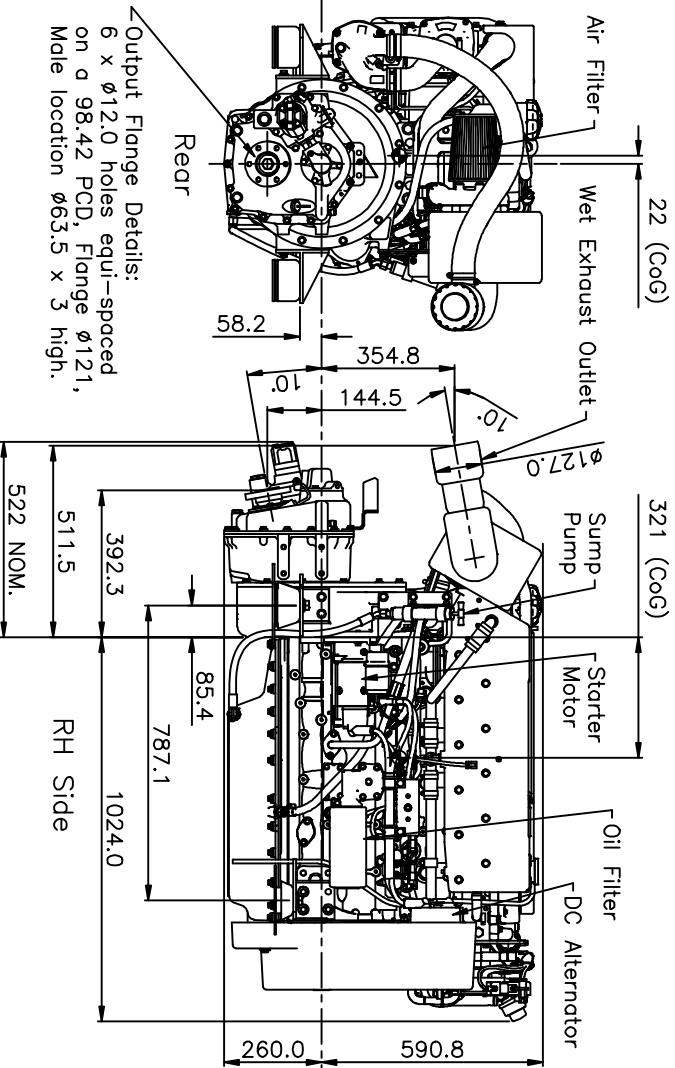
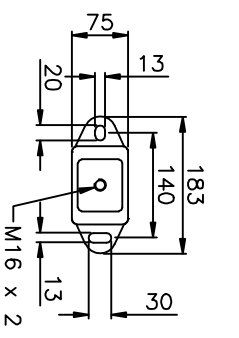
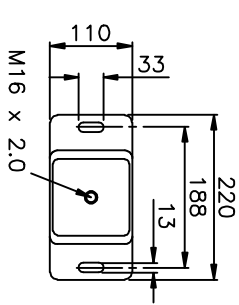
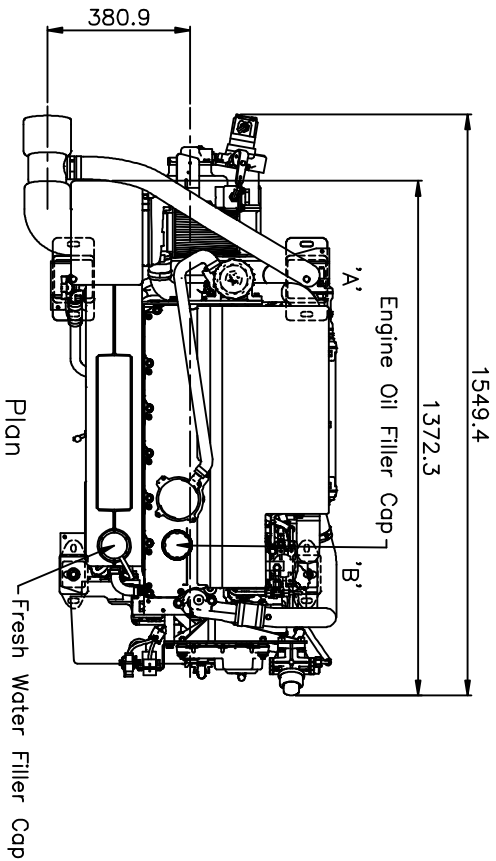

Output Flange Details:
 6 x $\phi 12.0$ holes equi-spaced
 on a 98.42 PCD, Flange $\phi 121$,
 Male location $\phi 63.5$ x 3 high.

