

Perkins M216C & M190C Marine Diesel Engine
 Shown with ZF63A gearbox with reduction ratios up to
 and including 2:1 ratios (622 mm transverse mounting centres)

WIMBORNE MARINE POWER CENTRE
 Wimborne, Dorset, England.
 Tel. +44(0)1202 893720
 Fax. +44(0)1202 851700
 E-mail. Wimborne_MPC_post@cat.com
www.Perkins-Sabre.com

Total Dry Weight: 746kg

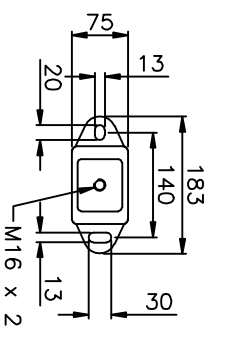
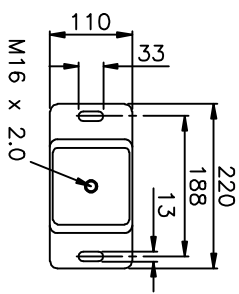
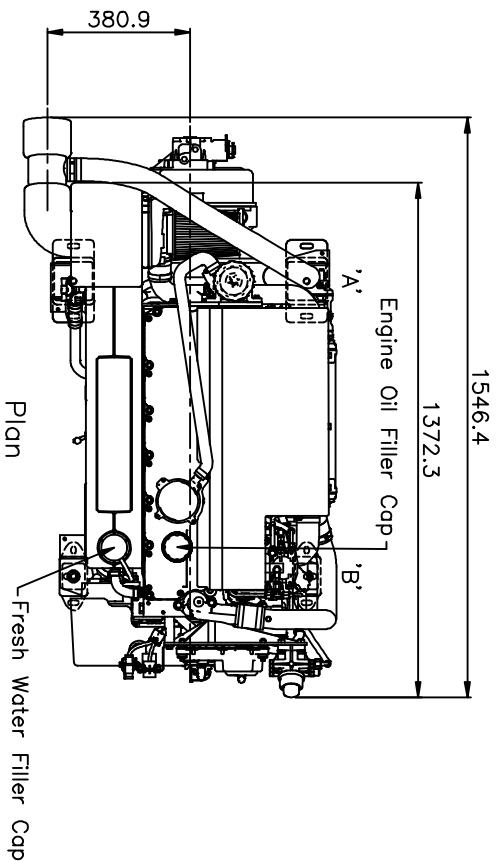

FLEXIBLE ENGINE MOUNT 'A'

FLEXIBLE ENGINE MOUNT 'B'

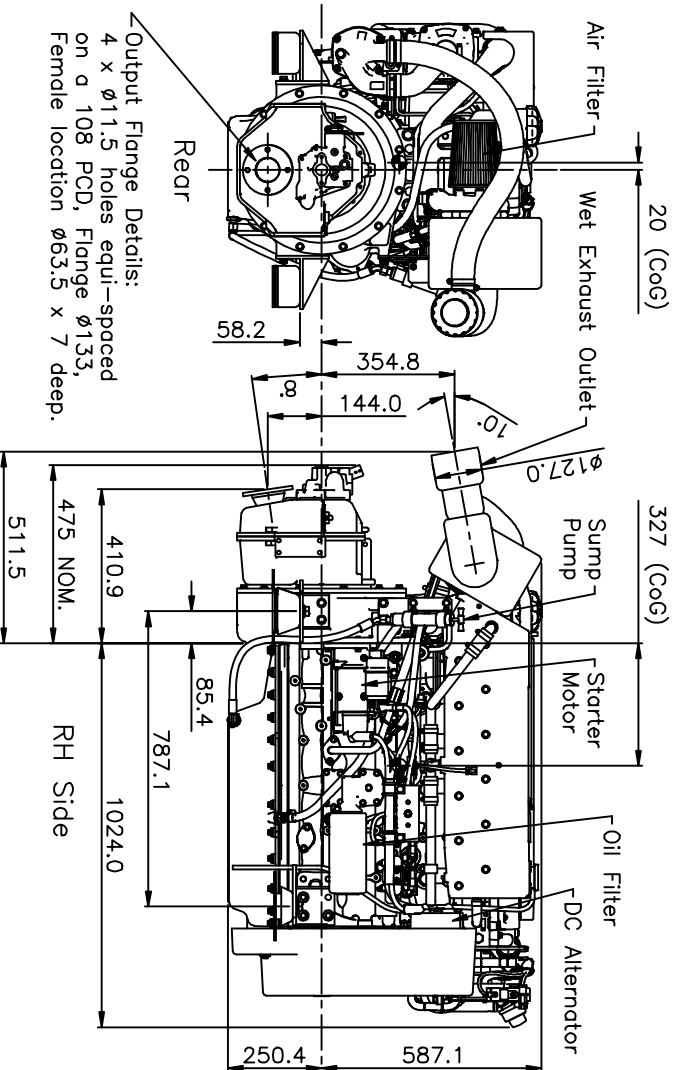

Output Flange Details:
 4 x $\phi 11.5$ holes equi-spaced
 on a 108 PCD, Flange $\phi 133$,
 Female location $\phi 63.5 \times 7$ deep.

