

Perkins Sabre M92B Marine Diesel Engine shown with PRM 500D gearbox with reduction ratios up to and including 2.90:1 (550mm transverse mounting centres)

CATERPILLAR MARINE POWER UK LTD
 Wimborne, Dorset, England.
 Tel. +44(0)1202 893720
 Fax. +44(0)1202 851700
 E-mail. Wimborne_MPC_post@cat.com
 www.Perkins-Sabre.com

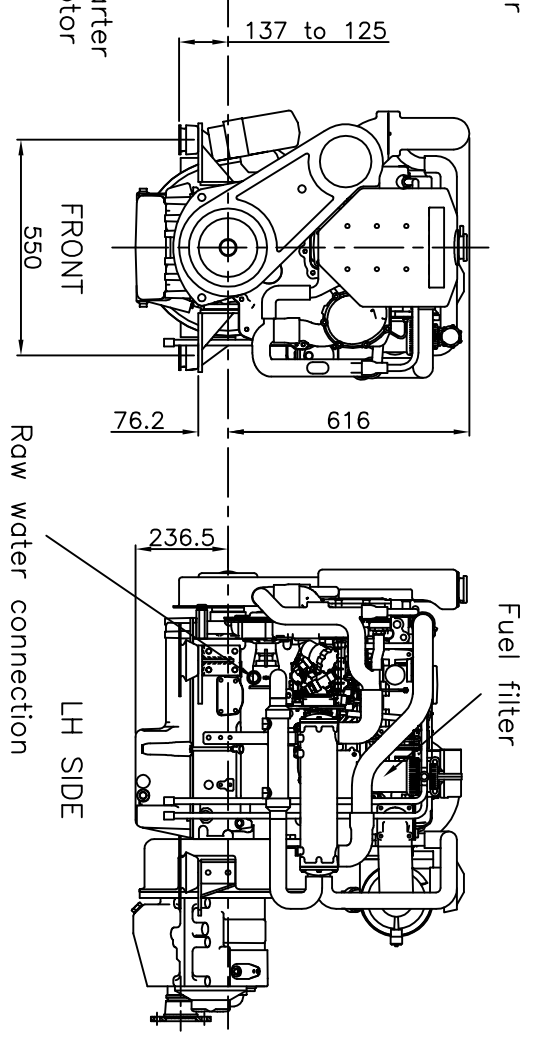
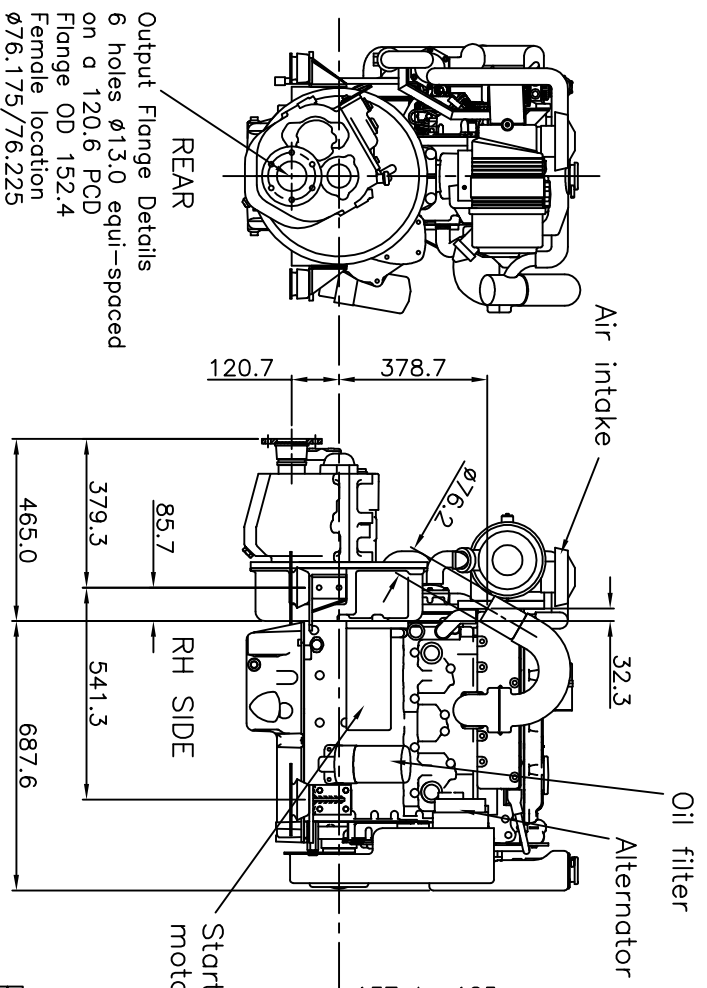
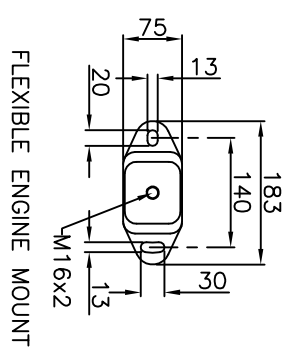
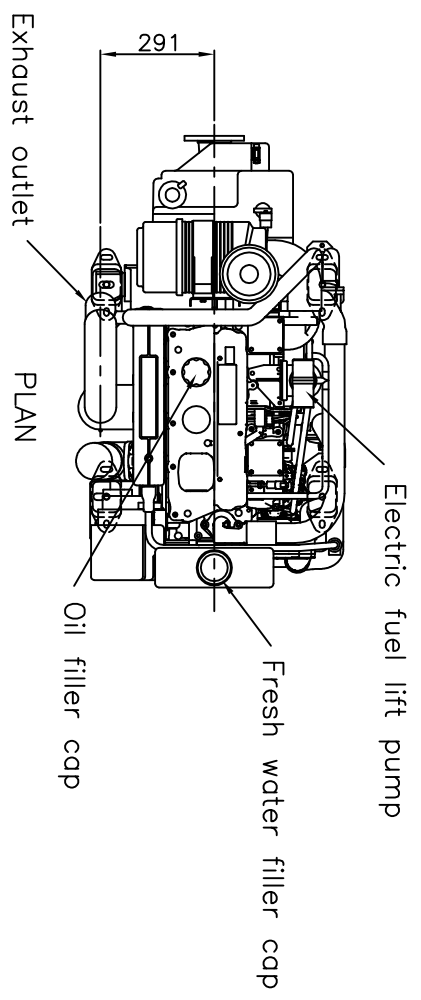

PROVISIONAL DRAWING

Doc No. 7353-1-04