

Operation and Maintenance Manual

1104D (Mech) Industrial Engine

NK (Engine)
NL (Engine)
NM (Engine)

Important Safety Information

Most accidents that involve product operation, maintenance and repair are caused by failure to observe basic safety rules or precautions. An accident can often be avoided by recognizing potentially hazardous situations before an accident occurs. A person must be alert to potential hazards. This person should also have the necessary training, skills and tools to perform these functions properly.

Improper operation, lubrication, maintenance or repair of this product can be dangerous and could result in injury or death.

Do not operate or perform any lubrication, maintenance or repair on this product, until you have read and understood the operation, lubrication, maintenance and repair information.

Safety precautions and warnings are provided in this manual and on the product. If these hazard warnings are not heeded, bodily injury or death could occur to you or to other persons.

The hazards are identified by the "Safety Alert Symbol" and followed by a "Signal Word" such as "DANGER", "WARNING" or "CAUTION". The Safety Alert "WARNING" label is shown below.



The meaning of this safety alert symbol is as follows:

Attention! Become Alert! Your Safety is Involved.

The message that appears under the warning explains the hazard and can be either written or pictorially presented.

Operations that may cause product damage are identified by "NOTICE" labels on the product and in this publication.

Perkins cannot anticipate every possible circumstance that might involve a potential hazard. The warnings in this publication and on the product are, therefore, not all inclusive. If a tool, procedure, work method or operating technique that is not specifically recommended by Perkins is used, you must satisfy yourself that it is safe for you and for others. You should also ensure that the product will not be damaged or be made unsafe by the operation, lubrication, maintenance or repair procedures that you choose.

The information, specifications, and illustrations in this publication are on the basis of information that was available at the time that the publication was written. The specifications, torques, pressures, measurements, adjustments, illustrations, and other items can change at any time. These changes can affect the service that is given to the product. Obtain the complete and most current information before you start any job. Perkins dealers or Perkins distributors have the most current information available.



When replacement parts are required for this product Perkins recommends using Perkins replacement parts.

Failure to heed this warning can lead to premature failures, product damage, personal injury or death.

Table of Contents

Foreword	4
Safety Section	
Safety Messages	5
General Hazard Information	6
Burn Prevention	8
Fire Prevention and Explosion Prevention	8
Crushing Prevention and Cutting Prevention	10
Before Starting Engine	10
Engine Starting	10
Engine Stopping	11
Electrical System	11
Product Information Section	
Model Views	13
Product Identification Information	18
Operation Section	
Lifting and Storage	20
Gauges and Indicators	22
Features and Controls	23
Engine Starting	24
Engine Operation	27
Engine Stopping	28
Cold Weather Operation	29
Maintenance Section	
Refill Capacities	33
Maintenance Interval Schedule	50
Warranty Section	
Warranty Information	79
Index Section	
Index	80

Foreword

Literature Information

This manual contains safety, operation instructions, lubrication and maintenance information. This manual should be stored in or near the engine area in a literature holder or literature storage area. Read, study and keep it with the literature and engine information.

English is the primary language for all Perkins publications. The English used facilitates translation and consistency.

Some photographs or illustrations in this manual show details or attachments that may be different from your engine. Guards and covers may have been removed for illustrative purposes. Continuing improvement and advancement of product design may have caused changes to your engine which are not included in this manual. Whenever a question arises regarding your engine, or this manual, please consult with your Perkins dealer or your Perkins distributor for the latest available information.

Safety

This safety section lists basic safety precautions. In addition, this section identifies hazardous, warning situations. Read and understand the basic precautions listed in the safety section before operating or performing lubrication, maintenance and repair on this product.

Operation

Operating techniques outlined in this manual are basic. They assist with developing the skills and techniques required to operate the engine more efficiently and economically. Skill and techniques develop as the operator gains knowledge of the engine and its capabilities.

The operation section is a reference for operators. Photographs and illustrations guide the operator through procedures of inspecting, starting, operating and stopping the engine. This section also includes a discussion of electronic diagnostic information.

Maintenance

The maintenance section is a guide to engine care. The illustrated, step-by-step instructions are grouped by service hours and/or calendar time maintenance intervals. Items in the maintenance schedule are referenced to detailed instructions that follow.

Recommended service should be performed at the appropriate intervals as indicated in the Maintenance Interval Schedule. The actual operating environment of the engine also governs the Maintenance Interval Schedule. Therefore, under extremely severe, dusty, wet or freezing cold operating conditions, more frequent lubrication and maintenance than is specified in the Maintenance Interval Schedule may be necessary.

The maintenance schedule items are organized for a preventive maintenance management program. If the preventive maintenance program is followed, a periodic tune-up is not required. The implementation of a preventive maintenance management program should minimize operating costs through cost avoidances resulting from reductions in unscheduled downtime and failures.

Maintenance Intervals

Perform maintenance on items at multiples of the original requirement. We recommend that the maintenance schedules be reproduced and displayed near the engine as a convenient reminder. We also recommend that a maintenance record be maintained as part of the engine's permanent record.

Your authorized Perkins dealer or your Perkins distributor can assist you in adjusting your maintenance schedule to meet the needs of your operating environment.

Overhaul

Major engine overhaul details are not covered in the Operation and Maintenance Manual except for the interval and the maintenance items in that interval. Major repairs should only be carried out by Perkins authorized personnel. Your Perkins dealer or your Perkins distributor offers a variety of options regarding overhaul programs. If you experience a major engine failure, there are also numerous after failure overhaul options available. Consult with your Perkins dealer or your Perkins distributor for information regarding these options.

California Proposition 65 Warning

Diesel engine exhaust and some of its constituents are known to the State of California to cause cancer, birth defects, and other reproductive harm. Battery posts, terminals and related accessories contain lead and lead compounds. **Wash hands after handling.**

Safety Section

The Universal Warning label (2) is located on the rear end of the valve mechanism cover. Refer to illustration 2.

i02690461

Safety Messages

There may be several specific warning signs on your engine. The exact location and a description of the warning signs are reviewed in this section. Please become familiar with all warning signs.

Ensure that all of the warning signs are legible. Clean the warning signs or replace the warning signs if the words cannot be read or if the illustrations are not visible. Use a cloth, water, and soap to clean the warning signs. Do not use solvents, gasoline, or other harsh chemicals. Solvents, gasoline, or harsh chemicals could loosen the adhesive that secures the warning signs. The warning signs that are loosened could drop off of the engine.

Replace any warning sign that is damaged or missing. If a warning sign is attached to a part of the engine that is replaced, install a new warning sign on the replacement part. Your Perkins dealer or your distributor can provide new warning signs.

(1) Universal Warning

 **WARNING**

Do not operate or work on this equipment unless you have read and understand the instructions and warnings in the Operation and Maintenance Manuals. Failure to follow the instructions or heed the warnings could result in serious injury or death.

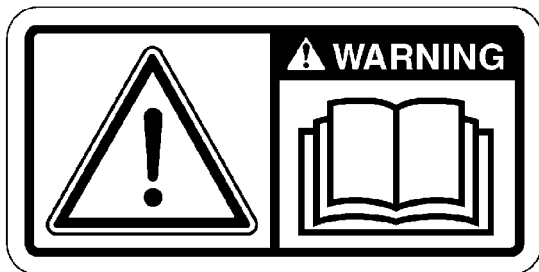

Illustration 1

g01154807

Typical example

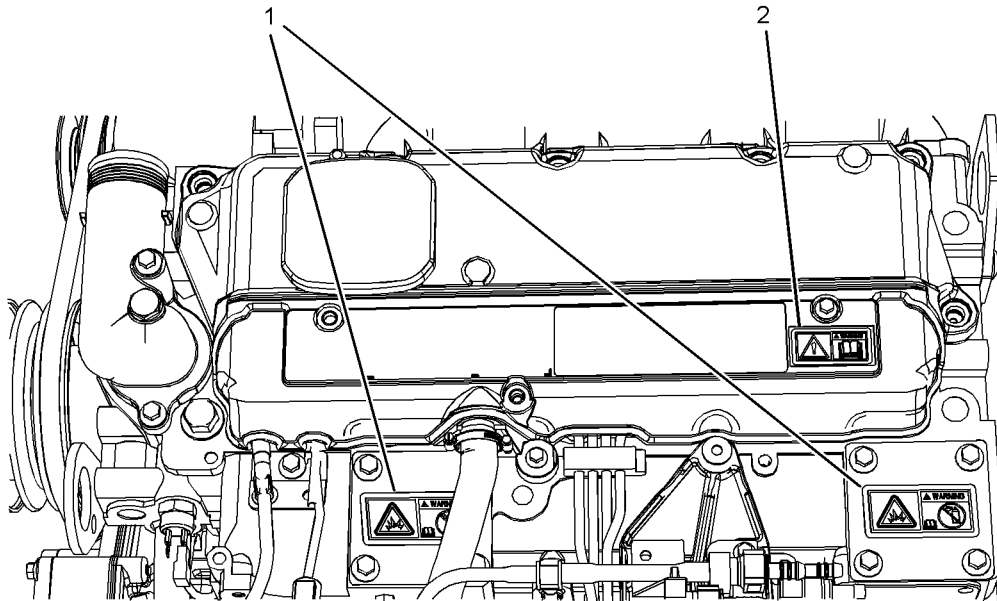

Illustration 2

g01353108

(1) Ether Warning Label

(2) Universal warning

(2) Ether

i02677370

⚠ WARNING
Do not use aerosol types of starting aids such as ether. Such use could result in an explosion and personal injury.

General Hazard Information



Illustration 3

g01154809

Typical example

The ether warning label (1) is located on the inlet manifold cover. Refer to illustration 2.

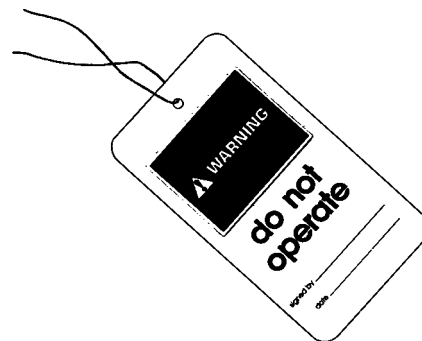

Illustration 4

g00104545

Attach a "Do Not Operate" warning tag or a similar warning tag to the start switch or to the controls before you service the equipment or before you repair the equipment.

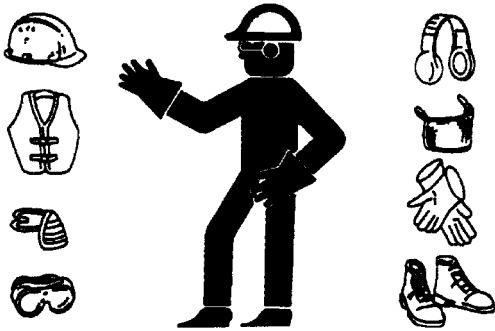

Illustration 5

g00702020

Wear a hard hat, protective glasses, and other protective equipment, as required.

Do not wear loose clothing or jewelry that can snag on controls or on other parts of the engine.

Make sure that all protective guards and all covers are secured in place on the engine.

Keep the engine free from foreign material. Remove debris, oil, tools, and other items from the deck, from walkways, and from steps.

Never put maintenance fluids into glass containers. Drain all liquids into a suitable container.

Obey all local regulations for the disposal of liquids.

Use all cleaning solutions with care.

Report all necessary repairs.

Do not allow unauthorized personnel on the equipment.

Ensure that the power supply is disconnected before you work on the bus bar or the glow plugs.

Perform maintenance on the engine with the equipment in the servicing position. Refer to the OEM information for the procedure for placing the equipment in the servicing position.

Pressure Air and Water

Pressurized air and/or water can cause debris and/or hot water to be blown out. This could result in personal injury.

The direct application of pressurized air or pressurized water to the body could result in personal injury.

When pressurized air and/or water is used for cleaning, wear protective clothing, protective shoes, and eye protection. Eye protection includes goggles or a protective face shield.

The maximum air pressure for cleaning purposes must be below 205 kPa (30 psi). The maximum water pressure for cleaning purposes must be below 275 kPa (40 psi).

Fluid Penetration

Pressure can be trapped in the hydraulic circuit long after the engine has been stopped. The pressure can cause hydraulic fluid or items such as pipe plugs to escape rapidly if the pressure is not relieved correctly.

Do not remove any hydraulic components or parts until pressure has been relieved or personal injury may occur. Do not disassemble any hydraulic components or parts until pressure has been relieved or personal injury may occur. Refer to the OEM information for any procedures that are required to relieve the hydraulic pressure.

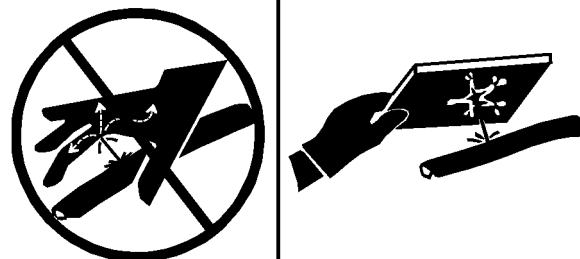

Illustration 6

g00687600

Always use a board or cardboard when you check for a leak. Leaking fluid that is under pressure can penetrate body tissue. Fluid penetration can cause serious injury and possible death. A pin hole leak can cause severe injury. If fluid is injected into your skin, you must get treatment immediately. Seek treatment from a doctor that is familiar with this type of injury.

Containing Fluid Spillage

Care must be taken in order to ensure that fluids are contained during performance of inspection, maintenance, testing, adjusting and repair of the engine. Make provision to collect the fluid with a suitable container before any compartment is opened or before any component is disassembled.

- Only use the tools that are suitable for collecting fluids and equipment that is suitable for collecting fluids.

- Only use the tools that are suitable for containing fluids and equipment that is suitable for containing fluids.

Obey all local regulations for the disposal of liquids.

i02143195

Burn Prevention

Do not touch any part of an operating engine. Allow the engine to cool before any maintenance is performed on the engine. Relieve all pressure in the air system, in the hydraulic system, in the lubrication system, in the fuel system, or in the cooling system before any lines, fittings or related items are disconnected.

Coolant

When the engine is at operating temperature, the engine coolant is hot. The coolant is also under pressure. The radiator and all lines to the heaters or to the engine contain hot coolant.

Any contact with hot coolant or with steam can cause severe burns. Allow cooling system components to cool before the cooling system is drained.

Check the coolant level after the engine has stopped and the engine has been allowed to cool.

Ensure that the filler cap is cool before removing the filler cap. The filler cap must be cool enough to touch with a bare hand. Remove the filler cap slowly in order to relieve pressure.

Cooling system conditioner contains alkali. Alkali can cause personal injury. Do not allow alkali to contact the skin, the eyes, or the mouth.

Oils

Hot oil and hot lubricating components can cause personal injury. Do not allow hot oil to contact the skin. Also, do not allow hot components to contact the skin.

Batteries

Electrolyte is an acid. Electrolyte can cause personal injury. Do not allow electrolyte to contact the skin or the eyes. Always wear protective glasses for servicing batteries. Wash hands after touching the batteries and connectors. Use of gloves is recommended.

i02813488

Fire Prevention and Explosion Prevention



Illustration 7

g00704000

All fuels, most lubricants, and some coolant mixtures are flammable.

Flammable fluids that are leaking or spilled onto hot surfaces or onto electrical components can cause a fire. Fire may cause personal injury and property damage.

A flash fire may result if the covers for the engine crankcase are removed within fifteen minutes after an emergency shutdown.

Determine whether the engine will be operated in an environment that allows combustible gases to be drawn into the air inlet system. These gases could cause the engine to overspeed. Personal injury, property damage, or engine damage could result.

If the application involves the presence of combustible gases, consult your Perkins dealer and/or your Perkins distributor for additional information about suitable protection devices.

Remove all flammable combustible materials or conductive materials such as fuel, oil, and debris from the engine. Do not allow any flammable combustible materials or conductive materials to accumulate on the engine.

Store fuels and lubricants in correctly marked containers away from unauthorized persons. Store oily rags and any flammable materials in protective containers. Do not smoke in areas that are used for storing flammable materials.

Do not expose the engine to any flame.

Exhaust shields (if equipped) protect hot exhaust components from oil or fuel spray in case of a line, a tube, or a seal failure. Exhaust shields must be installed correctly.

Do not weld on lines or tanks that contain flammable fluids. Do not flame cut lines or tanks that contain flammable fluid. Clean any such lines or tanks thoroughly with a nonflammable solvent prior to welding or flame cutting.

Wiring must be kept in good condition. All electrical wires must be correctly routed and securely attached. Check all electrical wires daily. Repair any wires that are loose or frayed before you operate the engine. Clean all electrical connections and tighten all electrical connections.

Eliminate all wiring that is unattached or unnecessary. Do not use any wires or cables that are smaller than the recommended gauge. Do not bypass any fuses and/or circuit breakers.

Arcing or sparking could cause a fire. Secure connections, recommended wiring, and correctly maintained battery cables will help to prevent arcing or sparking.

Inspect all lines and hoses for wear or for deterioration. The hoses must be correctly routed. The lines and hoses must have adequate support and secure clamps. Tighten all connections to the recommended torque. Leaks can cause fires.

Oil filters and fuel filters must be correctly installed. The filter housings must be tightened to the correct torque.

Use caution when you are refueling an engine. Do not smoke while you are refueling an engine. Do not refuel an engine near open flames or sparks. Always stop the engine before refueling.

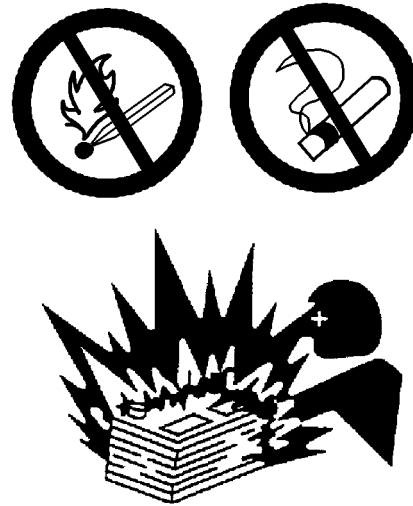

Illustration 9

g00704135

Gases from a battery can explode. Keep any open flames or sparks away from the top of a battery. Do not smoke in battery charging areas.

Never check the battery charge by placing a metal object across the terminal posts. Use a voltmeter or a hydrometer.

Incorrect jumper cable connections can cause an explosion that can result in injury. Refer to the Operation Section of this manual for specific instructions.

Do not charge a frozen battery. This may cause an explosion.

The batteries must be kept clean. The covers (if equipped) must be kept on the cells. Use the recommended cables, connections, and battery box covers when the engine is operated.

Fire Extinguisher

Make sure that a fire extinguisher is available. Be familiar with the operation of the fire extinguisher. Inspect the fire extinguisher and service the fire extinguisher regularly. Obey the recommendations on the instruction plate.



Illustration 8

g00704059

Lines, Tubes and Hoses

Do not bend high pressure lines. Do not strike high pressure lines. Do not install any lines that are bent or damaged. Do not clip any other items to the high pressure lines.

Repair any lines that are loose or damaged. Leaks can cause fires. Consult your Perkins dealer or your Perkins distributor for repair or for replacement parts.

Check lines, tubes and hoses carefully. Do not use your bare hand to check for leaks. Use a board or cardboard to check for leaks. Tighten all connections to the recommended torque.

Replace the parts if any of the following conditions are present:

- End fittings are damaged or leaking.
- Outer coverings are chafed or cut.
- Wires are exposed.
- Outer coverings are ballooning.
- Flexible part of the hoses are kinked.
- Outer covers have embedded armoring.
- End fittings are displaced.

Make sure that all clamps, guards, and heat shields are installed correctly. During engine operation, this will help to prevent vibration, rubbing against other parts, and excessive heat.

i02143194

Crushing Prevention and Cutting Prevention

Support the component correctly when work beneath the component is performed.

Unless other maintenance instructions are provided, never attempt adjustments while the engine is running.

Stay clear of all rotating parts and of all moving parts. Leave the guards in place until maintenance is performed. After the maintenance is performed, reinstall the guards.

Keep objects away from moving fan blades. The fan blades will throw objects or cut objects.

When objects are struck, wear protective glasses in order to avoid injury to the eyes.

Chips or other debris may fly off objects when objects are struck. Before objects are struck, ensure that no one will be injured by flying debris.

i02675470

Before Starting Engine

The initial start-up of a new engine or a engine that has been serviced or repaired make provision to shut the engine off, in order to stop an overspeed. This may be accomplished by shutting off the air and/or fuel supply to the engine.

Overspeed shutdown should occur automatically for engines that are controlled electronically. If automatic shutdown does not occur, press the emergency stop button in order to cut the fuel and/or air to the engine.

Inspect the engine for potential hazards.

Before starting the engine, ensure that no one is on, underneath, or close to the engine. Ensure that the area is free of personnel.

If equipped, ensure that the lighting system for the engine is suitable for the conditions. Ensure that all lights work correctly, if equipped.

All protective guards and all protective covers must be installed if the engine must be started in order to perform service procedures. To help prevent an accident that is caused by parts in rotation, work around the parts carefully.

Do not bypass the automatic shutoff circuits. Do not disable the automatic shutoff circuits. The circuits are provided in order to help prevent personal injury. The circuits are also provided in order to help prevent engine damage.

See the Service Manual for repairs and for adjustments.

i02678897

Engine Starting

WARNING

Do not use aerosol types of starting aids such as ether. Such use could result in an explosion and personal injury.

If a warning tag is attached to the engine start switch or to the controls, DO NOT start the engine or move the controls. Consult with the person that attached the warning tag before the engine is started.

All protective guards and all protective covers must be installed if the engine must be started in order to perform service procedures. To help prevent an accident that is caused by parts in rotation, work around the parts carefully.

Start the engine from the operator's compartment or from the engine start switch.

Always start the engine according to the procedure that is described in the Operation and Maintenance Manual, "Engine Starting" topic in the Operation Section. Knowing the correct procedure will help to prevent major damage to the engine components. Knowing the procedure will also help to prevent personal injury.

To ensure that the jacket water heater (if equipped) and/or the lube oil heater (if equipped) is working correctly, check the water temperature gauge and the oil temperature gauge during the heater operation.

Engine exhaust contains products of combustion which can be harmful to your health. Always start the engine and operate the engine in a well ventilated area. If the engine is started in an enclosed area, vent the engine exhaust to the outside.

Note: The engine is equipped with an automatic device for cold starting for normal conditions of operation. If the engine will be operated in very cold conditions, then an extra cold starting aid may be required. Normally, the engine will be equipped with the correct type of starting aid for your region of operation.

The engines are equipped with a glow plug starting aid in each individual cylinder that heats the intake air in order to improve starting.

i02678838

Engine Stopping

Stop the engine according to the procedure in the Operation and Maintenance Manual, "Engine Stopping (Operation Section)" in order to avoid overheating of the engine and accelerated wear of the engine components.

Use the Emergency Stop Button (if equipped) ONLY in an emergency situation. Do not use the Emergency Stop Button for normal engine stopping. After an emergency stop, DO NOT start the engine until the problem that caused the emergency stop has been corrected.

Stop the engine if an overspeed condition occurs during the initial start-up of a new engine or an engine that has been overhauled. This may be accomplished by shutting off the fuel supply to the engine and/or shutting off the air supply to the engine.

i02176668

Electrical System

Never disconnect any charging unit circuit or battery circuit cable from the battery when the charging unit is operating. A spark can cause the combustible gases that are produced by some batteries to ignite.

To help prevent sparks from igniting combustible gases that are produced by some batteries, the negative "-" jump start cable should be connected last from the external power source to the negative "-" terminal of the starting motor. If the starting motor is not equipped with a negative "-" terminal, connect the jump start cable to the engine block.

Check the electrical wires daily for wires that are loose or frayed. Tighten all loose electrical wires before the engine is started. Repair all frayed electrical wires before the engine is started. See the Operation and Maintenance Manual for specific starting instructions.

Grounding Practices

Correct grounding for the engine electrical system is necessary for optimum engine performance and reliability. Incorrect grounding will result in uncontrolled electrical circuit paths and in unreliable electrical circuit paths.

Uncontrolled electrical circuit paths can result in damage to main bearings, to crankshaft bearing journal surfaces, and to aluminum components.

Engines that are installed without engine-to-frame ground straps can be damaged by electrical discharge.

To ensure that the engine and the engine electrical systems function correctly, an engine-to-frame ground strap with a direct path to the battery must be used. This path may be provided by way of a direct engine ground to the frame.

All grounds should be tight and free of corrosion. The engine alternator must be grounded to the negative “-” battery terminal with a wire that is adequate to handle the full charging current of the alternator.

Product Information Section

Model Views

i02693072

Model View Illustrations

1104 Engine Model Views

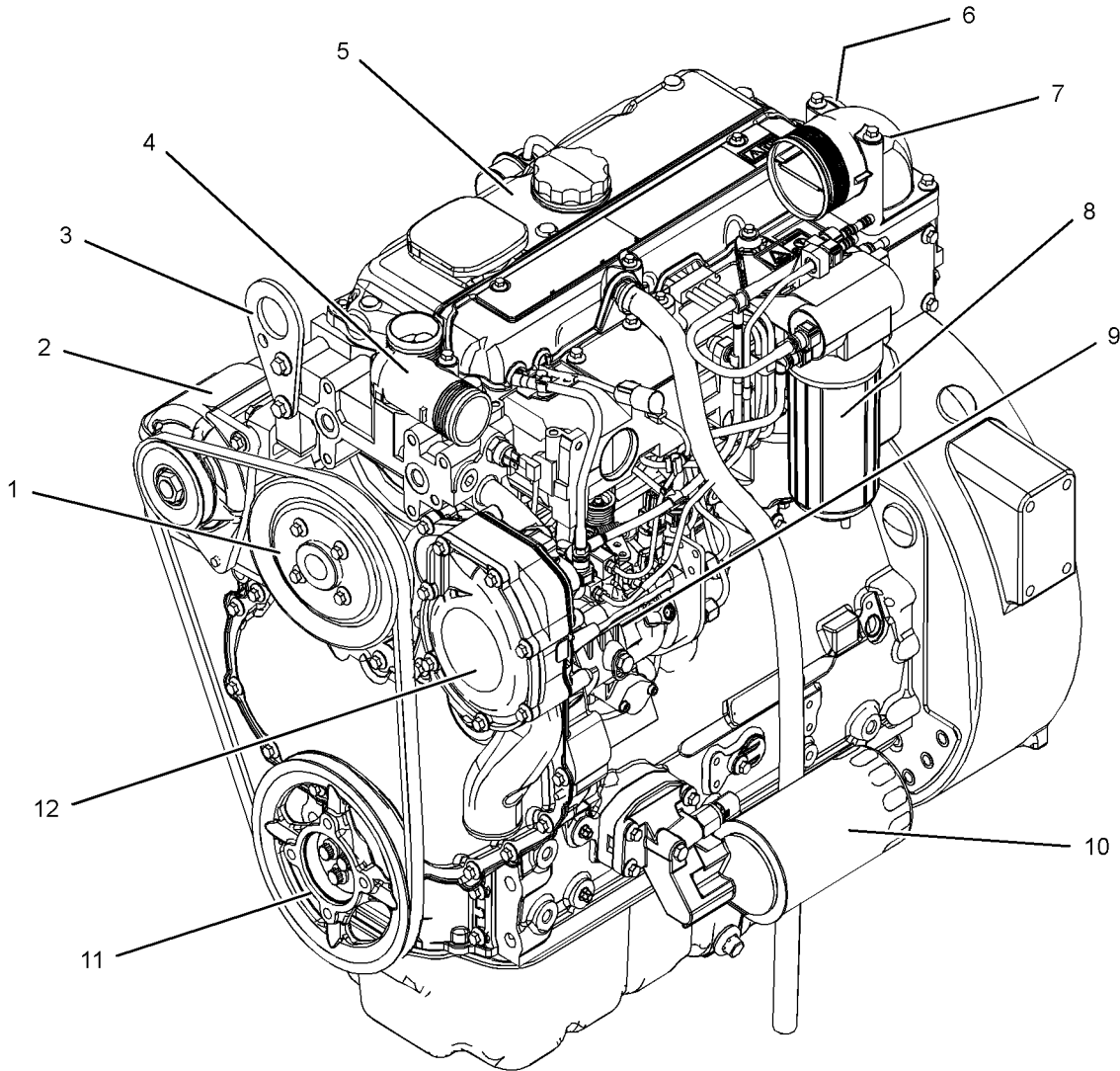

Illustration 10

g01351713

Typical example

- (1) Pulley
- (2) Alternator
- (3) Front Lifting Eye
- (4) Water Outlet

- (5) Valve Mechanism Cover
- (6) Rear Lifting Eye
- (7) Air Intake
- (8) Secondary Fuel Filter

- (9) Fuel Injection Pump
- (10) Oil Filter
- (11) Crankshaft Pulley
- (12) Water Pump

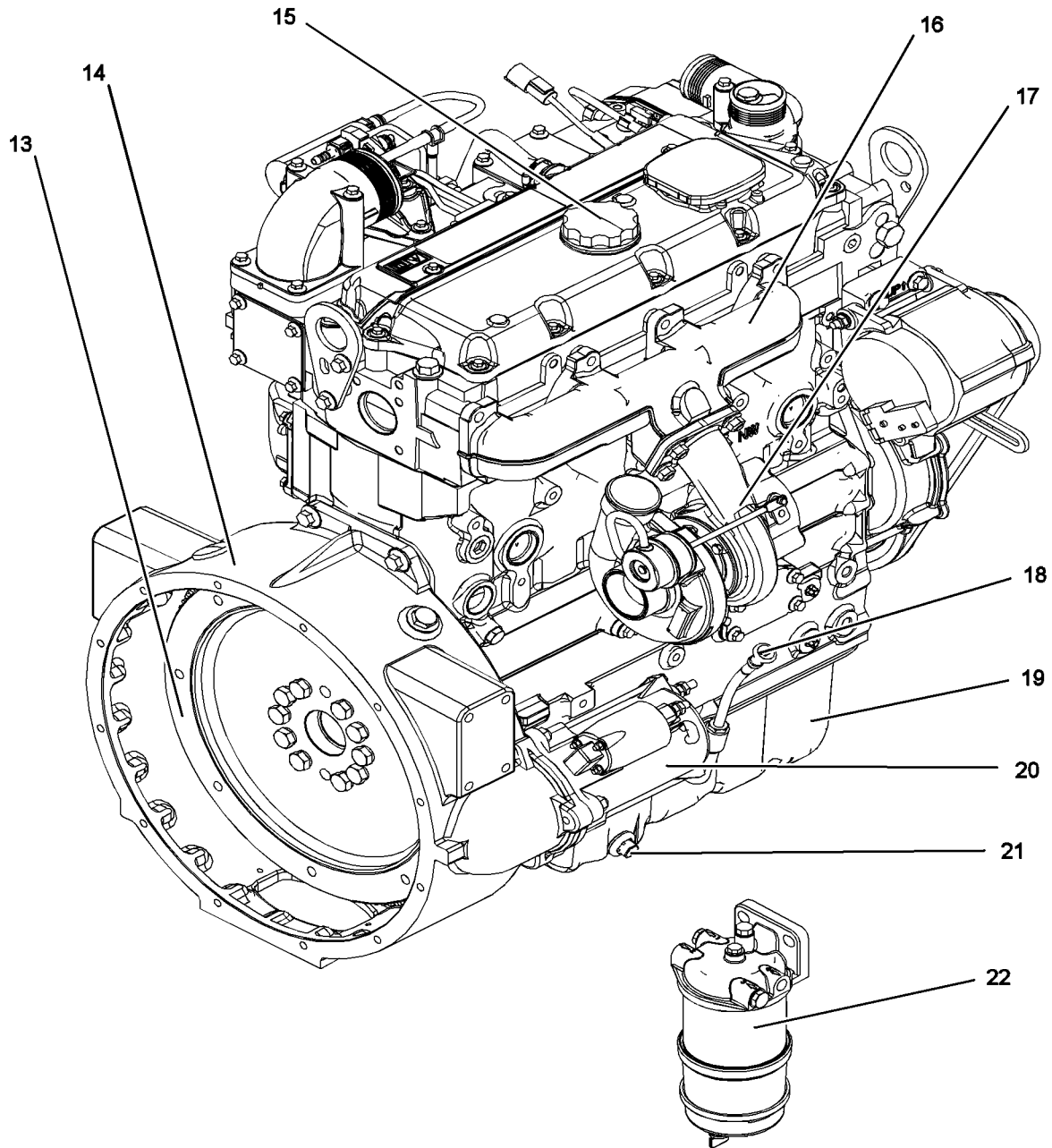

Illustration 11

g01352705

- (13) Flywheel
- (14) Flywheel Housing
- (15) Oil Filler Cap
- (16) Exhaust Manifold

- (17) Turbocharger
- (18) Oil Gauge
- (19) Oil Pan
- (20) Starting motor

- (21) Oil Drain Plug
- (22) Primary Fuel Filter

Note: The primary fuel filter may be mounted off the engine.

i04430909

Engine Description

The engines are available in the following types of aspiration:

- Turbocharged aftercooled
- Turbocharged
- Naturally aspirated

Engine Specifications

Note: The front end of the engine is opposite the flywheel end of the engine. The left and the right sides of the engine are determined from the flywheel end. The number 1 cylinder is the front cylinder.

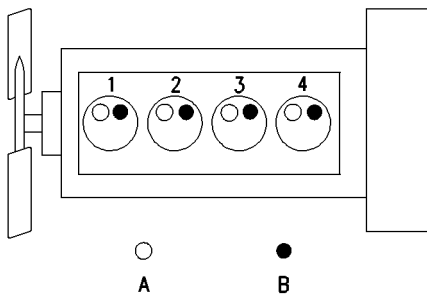

Illustration 12

g00984281

A typical example of the layout of the valves

(A) Inlet valves

(B) Exhaust valves

Emissions Control Systems

NK - Direct Diesel Injection

NL - Turbocharger, Direct Diesel Injection

NM - Turbocharger with Air to Air Charge Cooler,
Direct Diesel Injection

Table 1

1104D (Mech) Industrial Engine Specifications	
Number of Cylinders	4 In-Line
Bore	105 mm (4.134 inch)
Stroke	127 mm (5.0 inch)
Aspiration	Naturally aspirated Turbocharged Turbocharged aftercooled
Compression Ratio	NA 19.3:1 T, TA 18.2:1
Displacement	4.4 L (268 in ³)
Firing Order	1 3 4 2
Rotation (flywheel end)	Counterclockwise
Valve Lash Setting (Inlet)	0.20 mm (0.008 inch)
Valve Lash Setting (Exhaust)	0.45 mm (0.018 inch)

Engine Cooling and Lubrication

The cooling system consists of the following components:

- Gear-driven centrifugal water pump
- Water temperature regulator which regulates the engine coolant temperature
- Gear-driven oil pump (gear type)
- Oil cooler

The engine lubricating oil is supplied by a gear type pump. The engine lubricating oil is cooled and the engine lubricating oil is filtered. Bypass valves provide unrestricted flow of lubrication oil to the engine parts when oil viscosity is high. Bypass valves can also provide unrestricted flow of lubrication oil to the engine parts if the oil cooler should become plugged or if the oil filter element should become plugged.

Engine efficiency, efficiency of emission controls, and engine performance depend on adherence to proper operation and maintenance recommendations. Engine performance and efficiency also depend on the use of recommended fuels, lubrication oils, and coolants. Refer to the Operation and Maintenance Manual, "Maintenance Interval Schedule" for more information on maintenance items.

Engine Service Life

Engine efficiency and maximum utilization of engine performance depend on the adherence to proper operation and maintenance recommendations. In addition, use recommended fuels, coolants, and lubricants. Use the Operation and Maintenance Manual as a guide for required engine maintenance.

Expected engine life is generally predicted by the average power that is demanded. The average power that is demanded is based on fuel consumption of the engine over a time period. Reduced hours of operation at full throttle and/or operating at reduced throttle settings result in a lower average power demand. Reduced hours of operation will increase the length of operating time before an engine overhaul is required.

Product Identification Information

Engine Identification

i02680910

Perkins engines are identified by a serial number. This number is shown on a serial number plate that is mounted on the left hand side of the engine block.

An example of an engine number is NK12345U090001P.

NK _____ Type of engine
 NK12345 _____ Engine List Number
 U _____ Built in the United Kingdom
 090001 _____ Engine Serial Number
 P _____ Year of Manufacture

Perkins dealers need these numbers in order to determine the components that were included with the engine. This permits accurate identification of replacement part numbers.

i02681468

Serial Number Plate

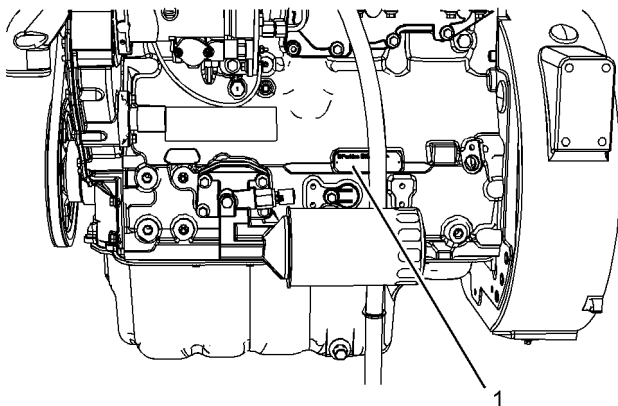

Illustration 13

g01347087

Location of serial number plate

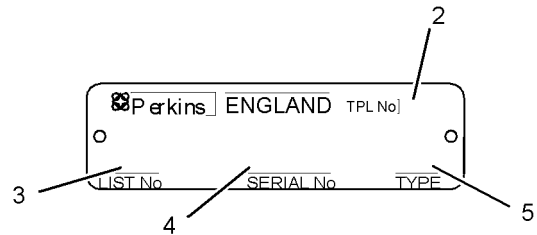

Illustration 14

g01347465

Typical serial number plate

- (2) Temporary Parts List number
- (3) List number
- (4) Serial number
- (5) Type

The Serial Number Plate (1) is located on the left side of the cylinder block to the rear of the engine.

The following information is stamped on the Serial Number Plate: Engine serial number, Model, and Arrangement number.

i02677372

Reference Numbers

Information for the following items may be needed to order parts. Locate the information for your engine. Record the information in the appropriate space. Make a copy of this list for a record. Keep the information for future reference.

Record for Reference

Engine Model _____

Engine Serial number _____

Engine Low Idle rpm _____

Engine Full Load rpm _____

Primary Fuel Filter _____

Water Separator Element _____

Secondary Fuel Filter Element _____

Lubrication Oil Filter Element _____

Auxiliary Oil Filter Element _____

Total Lubrication System Capacity _____

Total Cooling System Capacity _____

Air Cleaner Element _____

Fan Drive Belt _____

Alternator Belt _____

i02690481

Emissions Certification Film

IMPORTANT ENGINE INFORMATION		
Engine Family: #####12 #### ##### : #####12##### Engine Type: ##4#/ ##4# EPA Family: #####12#####		 120R-###6## e11*97/68## #####16##### ##4#: #####15#####
Advertised kw: ##5## @ RPM:##4# Fuel Rate at adv. kW: ##5## mm3/stk Init. Timing: #####l##### Disp:##4#	MLIT ###7##	
Settings are to be made with engine at normal operating temperature with transmission in neutral. This engine conforms to ##4# U.S. EPA non - road and California off - road Regulations for large C.I. engines and is certified to operate on commercially available diesel fuel.		
Emission Control System: #####16#####	Valve Lash Cold (inch): Exhaust ##5## Inlet ##5##	#####l ##### LABEL
Hanger No. #3#	Position ##4#	Label No. 3181A081

Illustration 15
Typical example

Operation Section

i04432996

Lifting and Storage

i02677363

Product Lifting

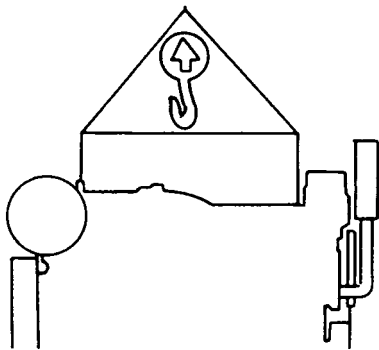

Illustration 16

g00103219

NOTICE

Never bend the eyebolts and the brackets. Only load the eyebolts and the brackets under tension. Remember that the capacity of an eyebolt is less as the angle between the supporting members and the object becomes less than 90 degrees.

When it is necessary to remove a component at an angle, only use a link bracket that is properly rated for the weight.

Use a hoist to remove heavy components. Use an adjustable lifting beam to lift the engine. All supporting members (chains and cables) should be parallel to each other. The chains and cables should be perpendicular to the top of the object that is being lifted.

Some removals require lifting the fixtures in order to obtain proper balance and safety.

To remove the engine ONLY, use the lifting eyes that are on the engine.

Lifting eyes are designed and installed for specific engine arrangements. Alterations to the lifting eyes and/or the engine make the lifting eyes and the lifting fixtures obsolete. If alterations are made, ensure that proper lifting devices are provided. Consult your Perkins dealer for information regarding fixtures for proper engine lifting.

Product Storage

Perkins are not responsible for damage which may occur when an engine is in storage after a period in service.

Your Perkins dealer or your Perkins distributor can assist in preparing the engine for extended storage periods.

Condition for Storage

The engine must be stored in a water proof building. The building must be kept at a constant temperature. Engines that are filled with Perkins ELC will have coolant protection to an ambient temperature of -36°C (-32.8°F). The engine must not be subjected to extreme variations in temperature and humidity.

Storage Period

An engine can be stored for up to 6 months provided all the recommendation are adhered to.

Storage Procedure

Keep a record of the procedure that has been completed on the engine.

Note: Do not store an engine that has biodiesel in the fuel system.

1. Ensure that the engine is clean and dry.
 - a. If the engine has been operated using biodiesel, the system must be drained and new filters installed. The fuel tank will require flushing.
 - b. Fill the fuel system with an acceptable fuel. For more information on acceptable fuels refer to this Operation and Maintenance Manual, "Fluid recommendations". Operate the engine for 15 minutes in order to remove all biodiesel from the system.
2. Drain any water from the primary filter water separator. Ensure that the fuel tank is full.
3. The engine oil will not need to be drained in order to store the engine. Provided the correct specification of engine oil is used the engine can be stored for up to 6 months. For the correct specification of engine oil refer to this Operation and Maintenance Manual, "Fluid recommendations".
4. Remove the drive belt from the engine.

Sealed Coolant System

Ensure that the cooling system is filled with Perkins ELC, or an antifreeze that meets "ASTM D6210" specification.

Open Cooling System

Ensure that all cooling drain plugs have been opened. Allow the coolant to drain. Install the drain plugs. Place a vapor phase inhibitor into the system. The coolant system must be sealed once the vapor phase inhibitor has been introduced. The effect of the vapor phase inhibitor will be lost if the cooling system is open to the atmosphere.

For maintenance procedures refer to this Operation and Maintenance Manual.

Monthly Checks

The crankshaft must be rotated in order to change the spring loading on the valve train. Rotate the crankshaft more than 180 degrees. Visibly check for damage or corrosion to the engine.

Ensure that the engine is covered completely before storage. Log the procedure in the record for the engine.

Gauges and Indicators

i02677374

Gauges and Indicators

Your engine may not have the same gauges or all of the gauges that are described. For more information about the gauge package, see the OEM information.

Gauges provide indications of engine performance. Ensure that the gauges are in good working order. Determine the normal operating range by observing the gauges over a period of time.

Noticeable changes in gauge readings indicate potential gauge or engine problems. Problems may also be indicated by gauge readings that change even if the readings are within specifications. Determine and correct the cause of any significant change in the readings. Consult your Perkins dealer or your Perkins distributor for assistance.

NOTICE

If no oil pressure is indicated, STOP the engine. If maximum coolant temperature is exceeded, STOP the engine. Engine damage can result.



Engine Oil Pressure – The oil pressure should be greatest after a cold engine is started. The typical engine oil pressure with SAE10W30 is 207 to 413 kPa (30 to 60 psi) at rated rpm.

A lower oil pressure is normal at low idle. If the load is stable and the gauge reading changes, perform the following procedure:

1. Remove the load.
2. Reduce engine speed to low idle.
3. Check and maintain the oil level.



Jacket Water Coolant Temperature – Typical temperature range is 71 to 96°C (160 to 205°F). The maximum allowable temperature with the pressurized cooling system at 48 kPa (7 psi) is 110°C (230°F). Higher temperatures may occur under certain conditions. The water temperature reading may vary according to load. The reading should never exceed the boiling point for the pressurized system that is being used.

If the engine is operating above the normal range and steam becomes apparent, perform the following procedure:

1. Reduce the load and the engine rpm.
2. Inspect the cooling system for leaks.
3. Determine if the engine must be shut down immediately or if the engine can be cooled by reducing the load.



Tachometer – This gauge indicates engine speed (rpm). When the throttle control lever is moved to the full throttle position without load, the engine is running at high idle. The engine is running at the full load rpm when the throttle control lever is at the full throttle position with maximum rated load.

NOTICE

To help prevent engine damage, never exceed the high idle rpm. Overspeeding can result in serious damage to the engine. The engine can be operated at high idle without damage, but should never be allowed to exceed high idle rpm.



Ammeter – This gauge indicates the amount of charge or discharge in the battery charging circuit. Operation of the indicator should be to the right side of “0” (zero).



Fuel Level – This gauge indicates the fuel level in the fuel tank. The fuel level gauge operates when the “START/STOP” switch is in the “ON” position.



Service Hour Meter – The gauge indicates operating time of the engine.

Features and Controls

i02690464

Fuel Shutoff

The fuel shutoff solenoid is located on the fuel injection pump.

When the fuel shutoff solenoid is activated, the solenoid moves to the "Open" position.

When the fuel shutoff solenoid is deactivated, the solenoid moves to the "Closed" position.

Engine Starting

i02675151

Before Starting Engine

Before the engine is started, perform the required daily maintenance and any other periodic maintenance that is due. Refer to the Operation and Maintenance Manual, "Maintenance Interval Schedule" for more information.

- For the maximum service life of the engine, make a thorough inspection within the engine compartment before the engine is started. Look for the following items: oil leaks, coolant leaks, loose bolts, and excessive dirt and/or grease. Remove any excess dirt and/or grease buildup. Repair any faults that were identified during the inspection.
- Inspect the cooling system hoses for cracks and for loose clamps.
- Inspect the alternator and accessory drive belts for cracks, breaks, and other damage.
- Inspect the wiring for loose connections and for worn wires or frayed wires.
- Check the fuel supply. Drain water from the water separator (if equipped). Open the fuel supply valve (if equipped).

NOTICE

All valves in the fuel return line must be open before and during engine operation to help prevent high fuel pressure. High fuel pressure may cause filter housing failure or other damage.

If the engine has not been started for several weeks, fuel may have drained from the fuel system. Air may have entered the filter housing. Also, when fuel filters have been changed, some air pockets will be trapped in the engine. In these instances, prime the fuel system. Refer to the Operation and Maintenance Manual, "Fuel System - Prime" for more information on priming the fuel system.

WARNING

Engine exhaust contains products of combustion which may be harmful to your health. Always start and operate the engine in a well ventilated area and, if in an enclosed area, vent the exhaust to the outside.

- Do not start the engine or move any of the controls if there is a "DO NOT OPERATE" warning tag or similar warning tag attached to the start switch or to the controls.
- Ensure that the areas around the rotating parts are clear.
- All of the guards must be put in place. Check for damaged guards or for missing guards. Repair any damaged guards. Replace damaged guards and/or missing guards.
- Disconnect any battery chargers that are not protected against the high current drain that is created when the electric starting motor is engaged. Check electrical cables and check the battery for poor connections and for corrosion.
- Reset all of the shutoffs or alarm components (if equipped).
- Check the engine lubrication oil level. Maintain the oil level between the "MIN" mark and the "MAX" mark on the engine oil level gauge.
- Check the coolant level. Observe the coolant level in the header tank (if equipped). Maintain the coolant level to the "FULL" mark on the header tank.
- If the engine is not equipped with a header tank maintain the coolant level within 13 mm (0.5 inch) of the bottom of the filler pipe. If the engine is equipped with a sight glass, maintain the coolant level in the sight glass.
- Observe the air cleaner service indicator (if equipped). Service the air cleaner when the yellow diaphragm enters the red zone, or when the red piston locks in the visible position.
- Ensure that any equipment that is driven by the engine has been disengaged from the engine. Minimize electrical loads or remove any electrical loads.

i02678840

Starting the Engine

WARNING

Do not use aerosol types of starting aids such as ether. Such use could result in an explosion and personal injury.

Refer to the OEM for your type of controls. Use the following procedure to start the engine.

1. If equipped, move the throttle lever to the full throttle position before you start the engine.

NOTICE

Do not crank the engine for more than 30 seconds. Allow the electric starting motor to cool for two minutes before cranking the engine again.

2. Turn the engine start switch to the START position. Hold the engine start switch in the START position and crank the engine.
3. When the engine starts, release the engine start switch.
4. If equipped, slowly move the throttle lever to the low idle position and allow the engine to idle. Refer to the Operation and Maintenance Manual, "After Starting Engine" topic.
5. If the engine does not start, release the engine start switch and allow the electric starting motor to cool. Then, repeat steps 2 through step 4.
6. Turn the engine start switch to the OFF position in order to stop the engine.

i02678837

Starting with Jump Start Cables

WARNING

Improper jump start cable connections can cause an explosion resulting in personal injury.

Prevent sparks near the batteries. Sparks could cause vapors to explode. Do not allow jump start cable ends to contact each other or the engine.

Note: If it is possible, first diagnose the reason for the starting failure. Make any necessary repairs. If the engine will not start only due to the condition of the battery, either charge the battery, or start the engine with jump start cables.

The condition of the battery can be rechecked after the engine has been switched OFF.

NOTICE

Using a battery source with the same voltage as the electric starting motor. Use ONLY equal voltage for jump starting. The use of higher voltage will damage the electrical system.

Do not reverse the battery cables. The alternator can be damaged. Attach ground cable last and remove first.

When using an external electrical source to start the engine, turn the generator set control switch to the "OFF" position. Turn all electrical accessories OFF before attaching the jump start cables.

Ensure that the main power switch is in the OFF position before attaching the jump start cables to the engine being started.

1. Turn the start switch to the OFF position. Turn off all the engine's accessories.
2. Connect one positive end of the jump start cable to the positive cable terminal of the discharged battery. Connect the other positive end of the jump start cable to the positive cable terminal of the electrical source.
3. Connect one negative end of the jump start cable to the negative cable terminal of the electrical source. Connect the other negative end of the jump start cable to the engine block or to the chassis ground. This procedure helps to prevent potential sparks from igniting the combustible gases that are produced by some batteries.
4. Start the engine.
5. Immediately after the stalled engine is started, disconnect the jump start cables in reverse order.

After jump starting, the alternator may not be able to fully recharge batteries that are severely discharged. The batteries must be replaced or charged to the correct voltage with a battery charger after the engine is stopped. Many batteries which are considered unusable are still rechargeable. Refer to Operation and Maintenance Manual, "Battery - Replace" and Testing and Adjusting Manual, "Battery - Test".

i02674934

After Starting Engine

Note: In temperatures from 0 to 60°C (32 to 140°F), the warm-up time is approximately three minutes. In temperatures below 0°C (32°F), additional warm-up time may be required.

When the engine idles during warm-up, observe the following conditions:

- Check for any fluid or for any air leaks at idle rpm and at one-half full rpm (no load on the engine) before operating the engine under load. This is not possible in some applications.
- Operate the engine at low idle until all systems achieve operating temperatures. Check all gauges during the warm-up period.

Note: Gauge readings should be observed and the data should be recorded frequently while the engine is operating. Comparing the data over time will help to determine normal readings for each gauge. Comparing data over time will also help detect abnormal operating developments. Significant changes in the readings should be investigated.

Engine Operation

i02678851

Engine Operation

i02678894

Correct operation and maintenance are key factors in obtaining the maximum life and economy of the engine. If the directions in the Operation and Maintenance Manual are followed, costs can be minimized and engine service life can be maximized.

The engine can be operated at the rated rpm after the engine reaches operating temperature. The engine will reach normal operating temperature sooner during a low engine speed (rpm) and during a low power demand. This procedure is more effective than idling the engine at no load. The engine should reach operating temperature in a few minutes.

Gauge readings should be observed and the data should be recorded frequently while the engine is operating. Comparing the data over time will help to determine normal readings for each gauge. Comparing data over time will also help detect abnormal operating developments. Significant changes in the readings should be investigated.

Fuel Conservation Practices

The efficiency of the engine can affect the fuel economy. Perkins design and technology in manufacturing provides maximum fuel efficiency in all applications. Follow the recommended procedures in order to attain optimum performance for the life of the engine.

- Avoid spilling fuel.

Fuel expands when the fuel is warmed up. The fuel may overflow from the fuel tank. Inspect fuel lines for leaks. Repair the fuel lines, as needed.

- Be aware of the properties of the different fuels. Use only the recommended fuels.
- Avoid unnecessary idling.

Shut off the engine rather than idle for long periods of time.

- Observe the air cleaner service indicator frequently. Keep the air cleaner elements clean.
- Maintain the electrical systems.

One damaged battery cell will overwork the alternator. This will consume excess power and excess fuel.

- Ensure that the drive belts are correctly adjusted. The drive belts should be in good condition.
- Ensure that all of the connections of the hoses are tight. The connections should not leak.
- Ensure that the driven equipment is in good working order.
- Cold engines consume excess fuel. Utilize heat from the jacket water system and the exhaust system, when possible. Keep cooling system components clean and keep cooling system components in good repair. Never operate the engine without water temperature regulators. All of these items will help maintain operating temperatures.

Engine Stopping

i02678906

Stopping the Engine

i02677379

NOTICE

Stopping the engine immediately after it has been working under load can result in overheating and accelerated wear of the engine components.

If the engine has been operating at high rpm and/or high loads, run at low idle for at least three minutes to reduce and stabilize internal engine temperature before stopping the engine.

Avoiding hot engine shutdowns will maximize turbocharger shaft and bearing life.

Prior to stopping an engine that is being operated at low loads, operate the engine at low idle for 30 seconds before stopping. If the engine has been operating at highway speeds and/or at high loads, operate the engine at low idle for at least three minutes. This procedure will cause the internal engine temperature to be reduced and stabilized.

Ensure that the engine stopping procedure is understood. Stop the engine according to the shutoff system on the engine or refer to the instructions that are provided by the OEM.

- To stop the engine, turn the key to the OFF position.

i01903586

Emergency Stopping

NOTICE

Emergency shutoff controls are for EMERGENCY use ONLY. DO NOT use emergency shutoff devices or controls for normal stopping procedure.

The OEM may have equipped the application with an emergency stop button. For more information about the emergency stop button, refer to the OEM information.

Ensure that any components for the external system that support the engine operation are secured after the engine is stopped.

After Stopping Engine

Note: Before you check the engine oil, do not operate the engine for at least 10 minutes in order to allow the engine oil to return to the oil pan.

- Check the crankcase oil level. Maintain the oil level between the “MIN” mark and the “MAX” mark on the oil level dipstick.
 - If necessary, perform minor adjustments. Repair any leaks and tighten any loose bolts.
 - Note the required service interval. Perform the maintenance that is in the Operation and Maintenance Manual, “Maintenance Interval Schedule”.
 - Fill the fuel tank in order to help prevent accumulation of moisture in the fuel. Do not overfill the fuel tank.
-

NOTICE

Only use antifreeze/coolant mixtures recommended in the Refill Capacities and Recommendations topic that is in this Operation and Maintenance Manual. Failure to do so can cause engine damage.

- Allow the engine to cool. Check the coolant level.
- If freezing temperatures are expected, check the coolant for the correct antifreeze protection. The cooling system must be protected against freezing to the lowest expected outside temperature. Add the correct coolant/water mixture, if necessary.
- Perform all required periodic maintenance on all driven equipment. This maintenance is outlined in the instructions from the OEM.

Cold Weather Operation

i02680008

Cold Weather Operation

Perkins Diesel Engines can operate effectively in cold weather. During cold weather, the starting and the operation of the diesel engine is dependent on the following items:

- The type of fuel that is used
- The viscosity of the engine oil
- The operation of the glow plugs
- Optional Cold starting aid
- Battery condition

This section will cover the following information:

- Potential problems that are caused by cold weather operation
- Suggest steps which can be taken in order to minimize starting problems and operating problems when the ambient air temperature is between 0° to -40 °C (32° to 40 °F).

The operation and maintenance of an engine in freezing temperatures is complex. This is because of the following conditions:

- Weather conditions
- Engine applications

Recommendations from your Perkins dealer or your Perkins distributor are based on past proven practices. The information that is contained in this section provides guidelines for cold weather operation.

Hints for Cold Weather Operation

- If the engine will start, operate the engine until a minimum operating temperature of 81 °C (177.8 °F) is achieved. Achieving operating temperature will help prevent the intake valves and exhaust valves from sticking.
- The cooling system and the lubrication system for the engine do not lose heat immediately upon shutdown. This means that an engine can be shut down for a period of time and the engine can still have the ability to start readily.

- Install the correct specification of engine lubricant before the beginning of cold weather.
- Check all rubber parts (hoses, fan drive belts, etc) weekly.
- Check all electrical wiring and connections for any fraying or damaged insulation.
- Keep all batteries fully charged and warm.
- Fill the fuel tank at the end of each shift.
- Check the air cleaners and the air intake daily. Check the air intake more often when you operate in snow.
- Ensure that the glow plugs are in working order. Refer to Testing and Adjusting Manual, "Glow Plug - Test".

WARNING

Personal injury or property damage can result from alcohol or starting fluids.

Alcohol or starting fluids are highly flammable and toxic and if improperly stored could result in injury or property damage.

WARNING

Do not use aerosol types of starting aids such as ether. Such use could result in an explosion and personal injury.

- For jump starting with cables in cold weather, refer to the Operation and Maintenance Manual, "Starting with Jump Start Cables." for instructions.

Viscosity of the Engine Lubrication Oil

Correct engine oil viscosity is essential. Oil viscosity affects the amount of torque that is needed to crank the engine. Refer to this Operation and Maintenance Manual, "Fluid Recommendations" for the recommended viscosity of oil.

Recommendations for the Coolant

Provide cooling system protection for the lowest expected outside temperature. Refer to this Operation and Maintenance Manual, "Fluid Recommendations" for the recommended coolant mixture.

In cold weather, check the coolant often for the correct glycol concentration in order to ensure adequate freeze protection.

Engine Block Heaters

Engine block heaters (if equipped) heat the engine jacket water that surrounds the combustion chambers. This provides the following functions:

- Startability is improved.
- Warm up time is reduced.

An electric block heater can be activated once the engine is stopped. An effective block heater is typically a 1250/1500 W unit. Consult your Perkins dealer or your Perkins distributor for more information.

Idling the Engine

When idling after the engine is started in cold weather, increase the engine rpm from 1000 to 1200 rpm. This will warm up the engine more quickly. Maintaining an elevated low idle speed for extended periods will be easier with the installation of a hand throttle. The engine should not be “raced” in order to speed up the warm up process.

While the engine is idling, the application of a light load (parasitic load) will assist in achieving the minimum operating temperature. The minimum operating temperature is 82 °C (179.6 °F).

Recommendations for Coolant Warm Up

Warm up an engine that has cooled below normal operating temperatures due to inactivity. This should be performed before the engine is returned to full operation. During operation in very cold temperature conditions, damage to engine valve mechanisms can result from engine operation for short intervals. This can happen if the engine is started and the engine is stopped many times without being operated in order to warm up completely.

When the engine is operated below normal operating temperatures, fuel and oil are not completely burned in the combustion chamber. This fuel and oil causes soft carbon deposits to form on the valve stems. Generally, the deposits do not cause problems and the deposits are burned off during operation at normal engine operating temperatures.

When the engine is started and the engine is stopped many times without being operated in order to warm up completely, the carbon deposits become thicker. This will cause the following problems:

- Free operation of the valves is prevented.
- Valves become stuck.
- Pushrods are bent.
- Other damage to valve train components can result.

For this reason, when the engine is started, the engine must be operated until the coolant temperature is 71 °C (160 °F) minimum. Carbon deposits on the valve stems will be kept at a minimum and the free operation of the valves and the valve components will be maintained.

In addition, the engine must be thoroughly warmed in order to keep other engine parts in better condition and the service life of the engine will be generally extended. Lubrication will be improved. There will be less acid and less sludge in the oil. This will provide longer service life for the engine bearings, the piston rings, and other parts. However, limit unnecessary idle time to ten minutes in order to reduce wear and unnecessary fuel consumption.

The Water Temperature Regulator and Insulated Heater Lines

The engine is equipped with a water temperature regulator. When the engine coolant is below the correct operating temperature jacket water circulates through the engine cylinder block and into the engine cylinder head. The coolant then returns to the cylinder block via an internal passage that bypasses the valve of the coolant temperature regulator. This ensures that coolant flows around the engine under cold operating conditions. The water temperature regulator begins to open when the engine jacket water has reached the correct minimum operating temperature. As the jacket water coolant temperature rises above the minimum operating temperature the water temperature regulator opens further allowing more coolant through the radiator to dissipate excess heat.

The progressive opening of the water temperature regulator operates the progressive closing of the bypass passage between the cylinder block and head. This ensures maximum coolant flow to the radiator in order to achieve maximum heat dissipation.

Note: Perkins discourages the use of all air flow restriction devices such as radiator shutters. Restriction of the air flow can result in the following: high exhaust temperatures, power loss, excessive fan usage, and reduction in fuel economy.

A cab heater is beneficial in very cold weather. The feed from the engine and the return lines from the cab should be insulated in order to reduce heat loss to the outside air.

Insulating the Air Inlet and Engine Compartment

When temperatures below $-18\text{ }^{\circ}\text{C}$ ($-0\text{ }^{\circ}\text{F}$) will be frequently encountered, an air cleaner inlet that is located in the engine compartment may be specified. An air cleaner that is located in the engine compartment may also minimize the entry of snow into the air cleaner. Also, heat that is rejected by the engine helps to warm the intake air.

Additional heat can be retained around the engine by insulating the engine compartment.

i02683046

Fuel and the Effect from Cold Weather

Note: Only use grades of fuel that are recommended by Perkins. Refer to this Operation and Maintenance Manual, "Fluid Recommendations".

The following fuels can be used in this series of engine.

- Group 1
- Group 2
- Group 3
- Special Fuels

Perkins prefer only Group 1 and Group 2 fuels for use in this series of engines.

Group 1 fuels are the preferred Group of Fuels for general use by Perkins. Group 1 fuels maximize engine life and engine performance. Group 1 fuels are usually less available than Group 2 fuels. Frequently, Group 1 fuels are not available in colder climates during the winter.

Note: Group 2 fuels must have a maximum wear scar of 650 micrometers (HFRR to ISO 12156-1).

Group 2 fuels are considered acceptable for issues of warranty. This group of fuels may reduce the life of the engine, the engine's maximum power, and the engine's fuel efficiency.

When Group 2 diesel fuels are used the following components provide a means of minimizing problems in cold weather:

- Glow plugs (if equipped)
- Engine coolant heaters, which may be an OEM option
- Fuel heaters, which may be an OEM option
- Fuel line insulation, which may be an OEM option

There are three major differences between Group 1 fuels and Group 2 fuels. Group 1 fuels have the following different characteristics to Group 2 fuels.

- A lower cloud point
- A lower pour point
- A higher energy per unit volume of fuel

Note: Group 3 fuels reduce the life of the engine. The use of Group 3 fuels is not covered by the Perkins warranty.

Group 3 fuels include Low Temperature Fuels and Aviation Kerosene Fuels.

Special fuels include Biofuel.

The cloud point is a temperature that allows wax crystals to form in the fuel. These crystals can cause the fuel filters to plug.

The pour point is the temperature when diesel fuel will thicken. The diesel fuel becomes more resistant to flow through fuel lines, fuel filters, and fuel pumps.

Be aware of these facts when diesel fuel is purchased. Consider the average ambient air temperature for the engine's application. Engines that are fueled in one climate may not operate well if the engines are moved to another climate. Problems can result due to changes in temperature.

Before troubleshooting for low power or for poor performance in the winter, check the fuel for waxing.

Low temperature fuels may be available for engine operation at temperatures below $0\text{ }^{\circ}\text{C}$ ($32\text{ }^{\circ}\text{F}$). These fuels limit the formation of wax in the fuel at low temperatures.

For more information on cold weather operation, refer to the Operation and Maintenance Manual, "Cold Weather Operation and Fuel Related Components in Cold Weather".

i02678858

Fuel Related Components in Cold Weather

Fuel Tanks

Condensation can form in partially filled fuel tanks. Top off the fuel tanks after you operate the engine.

Fuel tanks should contain some provision for draining water and sediment from the bottom of the tanks.

Some fuel tanks use supply pipes that allow water and sediment to settle below the end of the fuel supply pipe.

Some fuel tanks use supply lines that take fuel directly from the bottom of the tank. If the engine is equipped with this system, regular maintenance of the fuel system filter is important.

Drain the water and sediment from any fuel storage tank at the following intervals: weekly, service intervals, and refueling of the fuel tank. This will help prevent water and/or sediment from being pumped from the fuel storage tank and into the engine fuel tank.

Fuel Filters

A primary fuel filter is installed between the fuel tank and the engine fuel inlet. After you change the fuel filter, always prime the fuel system in order to remove air bubbles from the fuel system. Refer to the Operation and Maintenance Manual in the Maintenance Section for more information on priming the fuel system.

The location of a primary fuel filter is important in cold weather operation. The primary fuel filter and the fuel supply line are the most common components that are affected by cold fuel.

Fuel Heaters

Note: The OEM may equip the application with fuel heaters. If this is the case, the temperature of the fuel must not exceed 73 °C (163 °F) at the fuel transfer pump.

For more information about fuel heaters (if equipped), refer to the OEM information.

Maintenance Section

i04478615

Refill Capacities

i02682592

Refill Capacities

Lubrication System

The refill capacities for the engine crankcase reflect the approximate capacity of the crankcase or sump plus standard oil filters. Auxiliary oil filter systems will require additional oil. Refer to the OEM specifications for the capacity of the auxiliary oil filter. Refer to the Operation and Maintenance Manual, "Maintenance Section" for more information on Lubricant Specifications.

Table 2

Engine Refill Capacities		
Compartment or System	Minimum	Maximum
Oil Pan ⁽¹⁾	5 L (1.1658 Imp gal)	7 L (1.5398 Imp gal)

⁽¹⁾ These values are the approximate capacities for the oil pan (aluminum) which includes the standard factory installed oil filters. Engines with auxiliary oil filters and alternative oil pans will require additional oil. Refer to the OEM specifications for the capacity of the auxiliary oil filter and the engine oil pan.

Cooling System

Refer to the OEM specifications for the External System capacity. This capacity information will be needed in order to determine the amount of coolant/antifreeze that is required for the Total Cooling System.

Table 3

Engine Refill Capacities	
Compartment or System	Liters
Engine Only	7 L (1.5398 Imp gal)
External System Per OEM ⁽¹⁾	

⁽¹⁾ The External System includes a radiator or an expansion tank with the following components: heat exchanger and piping. Refer to the OEM specifications. Enter the value for the capacity of the External System in this row.

Fluid Recommendations

General Lubricant Information

Because of government regulations regarding the certification of exhaust emissions from the engine, the lubricant recommendations must be followed.

Engine Manufacturers Association (EMA) Oils

The "Engine Manufacturers Association Recommended Guideline on Diesel Engine Oil" is recognized by Perkins. For detailed information about this guideline, see the latest edition of EMA publication, "EMA DHD -1".

API Oils

The Engine Oil Licensing and Certification System by the American Petroleum Institute (API) is recognized by Perkins. For detailed information about this system, see the latest edition of the "API publication No. 1509". Engine oils that bear the API symbol are authorized by API.

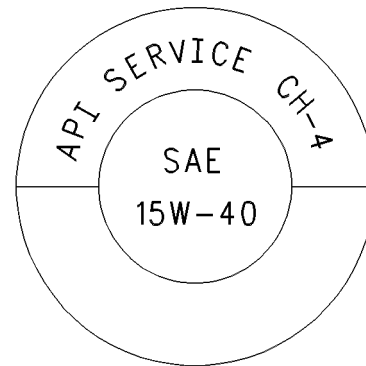

Illustration 17

g00546535

Typical API symbol

Diesel engine oils CC, CD, CD-2, and CE have not been API authorized classifications since 1 January 1996. Table 4 summarizes the status of the classifications.

Table 4

API Classifications	
Current	Obsolete
CH-4, , CI-4	CE, CC, CD
-	CD-2 ⁽¹⁾

⁽¹⁾ The oil CD-2 is for a two-cycle diesel engine. Perkins does not sell engines that utilize CD-2 oil.

Terminology

Certain abbreviations follow the nomenclature of "SAE J754". Some classifications follow "SAE J183" abbreviations, and some classifications follow the "EMA Recommended Guideline on Diesel Engine Oil". In addition to Perkins definitions, there are other definitions that will be of assistance in purchasing lubricants. Recommended oil viscosities can be found in this publication, "Fluid Recommendations/Engine Oil" topic (Maintenance Section).

Engine Oil

Commercial Oils

The performance of commercial diesel engine oils is based on American Petroleum Institute (API) classifications. These API classifications are developed in order to provide commercial lubricants for a broad range of diesel engines that operate at various conditions.

Only use commercial oils that meet the following classifications:

- API CH-4 CI-4

In order to make the correct choice of a commercial oil, refer to the following explanations:

EMA DHD-1 – The Engine Manufacturers Association (EMA) has developed lubricant recommendations as an alternative to the API oil classification system. DHD-1 is a Recommended Guideline that defines a level of oil performance for these types of diesel engines: high speed, four stroke cycle, heavy-duty, and light duty. DHD-1 oils may be used in Perkins engines when the following oils are recommended: API CH-4, API CG-4, and API CF-4. DHD-1 oils are intended to provide superior performance in comparison to API CG-4 and API CF-4.

DHD-1 oils will meet the needs of high performance Perkins diesel engines that are operating in many applications. The tests and the test limits that are used to define DHD-1 are similar to the new API CH-4 classification. Therefore, these oils will also meet the requirements for diesel engines that require low emissions. DHD-1 oils are designed to control the harmful effects of soot with improved wear resistance and improved resistance to plugging of the oil filter. These oils will also provide superior piston deposit control for engines with either two-piece steel pistons or aluminum pistons.

All DHD-1 oils must complete a full test program with the base stock and with the viscosity grade of the finished commercial oil. The use of "API Base Oil Interchange Guidelines" are not appropriate for DHD-1 oils. This feature reduces the variation in performance that can occur when base stocks are changed in commercial oil formulations.

DHD-1 oils are recommended for use in extended oil change interval programs that optimize the life of the oil. These oil change interval programs are based on oil analysis. DHD-1 oils are recommended for conditions that demand a premium oil. Your Perkins dealer or your Perkins distributor has the specific guidelines for optimizing oil change intervals.

API CH-4 – API CH-4 oils were developed in order to meet the requirements of the new high performance diesel engines. Also, the oil was designed to meet the requirements of the low emissions diesel engines. API CH-4 oils are also acceptable for use in older diesel engines and in diesel engines that use high sulfur diesel fuel. API CH-4 oils may be used in Perkins engines that use API CG-4 and API CF-4 oils. API CH-4 oils will generally exceed the performance of API CG-4 oils in the following criteria: deposits on pistons, control of oil consumption, wear of piston rings, valve train wear, viscosity control, and corrosion.

Three new engine tests were developed for the API CH-4 oil. The first test specifically evaluates deposits on pistons for engines with the two-piece steel piston. This test (piston deposit) also measures the control of oil consumption. A second test is conducted with moderate oil soot. The second test measures the following criteria: wear of piston rings, wear of cylinder liners, and resistance to corrosion. A third new test measures the following characteristics with high levels of soot in the oil: wear of the valve train, resistance of the oil in plugging the oil filter, and control of sludge.

In addition to the new tests, API CH-4 oils have tougher limits for viscosity control in applications that generate high soot. The oils also have improved oxidation resistance. API CH-4 oils must pass an additional test (piston deposit) for engines that use aluminum pistons (single piece). Oil performance is also established for engines that operate in areas with high sulfur diesel fuel.

All of these improvements allow the API CH-4 oil to achieve optimum oil change intervals. API CH-4 oils are recommended for use in extended oil change intervals. API CH-4 oils are recommended for conditions that demand a premium oil. Your Perkins dealer or your Perkins distributor has specific guidelines for optimizing oil change intervals.

Some commercial oils that meet the API classifications may require reduced oil change intervals. To determine the oil change interval, closely monitor the condition of the oil and perform a wear metal analysis.

NOTICE

Failure to follow these oil recommendations can cause shortened engine service life due to deposits and/or excessive wear.

Total Base Number (TBN) and Fuel Sulfur Levels for Direct Injection (DI) Diesel Engines

The Total Base Number (TBN) for an oil depends on the fuel sulfur level. For direct injection engines that use distillate fuel, the minimum TBN of the new oil must be ten times the fuel sulfur level. The TBN is defined by "ASTM D2896". The minimum TBN of the oil is 5 regardless of fuel sulfur level. Illustration 18 demonstrates the TBN.

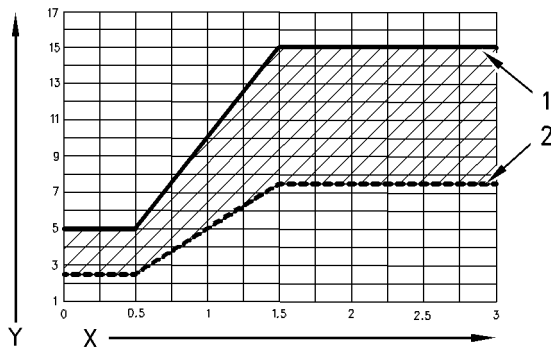

Illustration 18

g00799818

(Y) TBN by "ASTM D2896"

(X) Percentage of fuel sulfur by weight

(1) TBN of new oil

(2) Change the oil when the TBN deteriorates to 50 percent of the original TBN.

Use the following guidelines for fuel sulfur levels that exceed 1.5 percent:

- Choose an oil with the highest TBN that meets one of these classifications: EMA DHD-1 and API CH-4.
- Reduce the oil change interval. Base the oil change interval on the oil analysis. Ensure that the oil analysis includes the condition of the oil and a wear metal analysis.

Excessive piston deposits can be produced by an oil with a high TBN. These deposits can lead to a loss of control of the oil consumption and to the polishing of the cylinder bore.

NOTICE

Operating Direct Injection (DI) diesel engines with fuel sulphur levels over 0.5 percent will require shortened oil change intervals in order to help maintain adequate wear protection.

Table 5

Percentage of Sulfur in the fuel	Oil change interval
Lower than 0.5	Normal
0.5 to 1.0	0.75 of normal
Greater than 1.0	0.50 of normal

Lubricant Viscosity Recommendations for Direct Injection (DI) Diesel Engines

The correct SAE viscosity grade of oil is determined by the minimum ambient temperature during cold engine start-up, and the maximum ambient temperature during engine operation.

Refer to Table 6 (minimum temperature) in order to determine the required oil viscosity for starting a cold engine.

Refer to Table 6 (maximum temperature) in order to select the oil viscosity for engine operation at the highest ambient temperature that is anticipated.

Generally, use the highest oil viscosity that is available to meet the requirement for the temperature at start-up.

Table 6

Engine Oil Viscosity		
EMA LRG-1 API CH-4 Viscosity Grade	Ambient Temperature	
	Minimum	Maximum
SAE 0W20	-40 °C (-40 °F)	10 °C (50 °F)
SAE 0W30	-40 °C (-40 °F)	30 °C (86 °F)
SAE 0W40	-40 °C (-40 °F)	40 °C (104 °F)
SAE 5W30	-30 °C (-22 °F)	30 °C (86 °F)
SAE 5W40	-30 °C (-22 °F)	40 °C (104 °F)
SAE 10W30	-20 °C (-4 °F)	40 °C (104 °F)
SAE 15W40	-10 °C (14 °F)	50 °C (122 °F)

Synthetic Base Stock Oils

Synthetic base oils are acceptable for use in these engines if these oils meet the performance requirements that are specified for the engine.

Synthetic base oils generally perform better than conventional oils in the following two areas:

- Synthetic base oils have improved flow at low temperatures especially in arctic conditions.
- Synthetic base oils have improved oxidation stability especially at high operating temperatures.

Some synthetic base oils have performance characteristics that enhance the service life of the oil. Perkins does not recommend the automatic extending of the oil change intervals for any type of oil.

Re-refined Base Stock Oils

Re-refined base stock oils are acceptable for use in Perkins engines if these oils meet the performance requirements that are specified by Perkins. Re-refined base stock oils can be used exclusively in finished oil or in a combination with new base stock oils. The US military specifications and the specifications of other heavy equipment manufacturers also allow the use of re-refined base stock oils that meet the same criteria.

The process that is used to make re-refined base stock oil should adequately remove all wear metals that are in the used oil and all the additives that are in the used oil. The process that is used to make re-refined base stock oil generally involves the process of vacuum distillation and hydrotreating the used oil. Filtering is adequate for the production of high quality, re-refined base stock oil.

Lubricants for Cold Weather

When an engine is started and an engine is operated in ambient temperatures below -20°C (-4°F), use multigrade oils that are capable of flowing in low temperatures.

These oils have lubricant viscosity grades of SAE 0W or SAE 5W.

When an engine is started and operated in ambient temperatures below -30°C (-22°F), use a synthetic base stock multigrade oil with an 0W viscosity grade or with a 5W viscosity grade. Use an oil with a pour point that is lower than -50°C (-58°F).

The number of acceptable lubricants is limited in cold-weather conditions. Perkins recommends the following lubricants for use in cold-weather conditions:

First Choice – Use oil with an EMA DHD-1 Recommended Guideline. Use a CH-4 oil that has an API license. The oil should be either SAE 0W20, SAE 0W30, SAE 0W40, SAE 5W30, or SAE 5W40 lubricant viscosity grade.

Second Choice – Use an oil that has a CH-4 additive package. Although the oil has not been tested for the requirements of the API license, the oil must be either SAE 0W20, SAE 0W30, SAE 0W40, SAE 5W30, or SAE 5W40.

NOTICE

Shortened engine service life could result if second choice oils are used.

Aftermarket Oil Additives

Perkins does not recommend the use of aftermarket additives in oil. It is not necessary to use aftermarket additives in order to achieve the engine's maximum service life or rated performance. Fully formulated, finished oils consist of base oils and of commercial additive packages. These additive packages are blended into the base oils at precise percentages in order to help provide finished oils with performance characteristics that meet industry standards.

There are no industry standard tests that evaluate the performance or the compatibility of aftermarket additives in finished oil. Aftermarket additives may not be compatible with the finished oil's additive package, which could lower the performance of the finished oil. The aftermarket additive could fail to mix with the finished oil. This could produce sludge in the crankcase. Perkins discourages the use of aftermarket additives in finished oils.

To achieve the best performance from a Perkins engine, conform to the following guidelines:

- Select the correct oil, or a commercial oil that meets the “EMA Recommended Guideline on Diesel Engine Oil” or the recommended API classification.
- See the appropriate “Lubricant Viscosities” table in order to find the correct oil viscosity grade for your engine.
- At the specified interval, service the engine. Use new oil and install a new oil filter.
- Perform maintenance at the intervals that are specified in the Operation and Maintenance Manual, “Maintenance Interval Schedule”.

Oil analysis

Some engines may be equipped with an oil sampling valve. If oil analysis is required the oil sampling valve is used to obtain samples of the engine oil. The oil analysis will complement the preventive maintenance program.

The oil analysis is a diagnostic tool that is used to determine oil performance and component wear rates. Contamination can be identified and measured by using the oil analysis. The oil analysis includes the following tests:

- The Wear Rate Analysis monitors the wear of the engine's metals. The amount of wear metal and type of wear metal that is in the oil is analyzed. The increase in the rate of engine wear metal in the oil is as important as the quantity of engine wear metal in the oil.
- Tests are conducted in order to detect contamination of the oil by water, glycol, or fuel.
- The Oil Condition Analysis determines the loss of the oil's lubricating properties. An infrared analysis is used to compare the properties of new oil to the properties of the used oil sample. This analysis allows technicians to determine the amount of deterioration of the oil during use. This analysis also allows technicians to verify the performance of the oil according to the specification during the entire oil change interval.

i04478616

Fluid Recommendations (Coolant Information)

Cooling System Specifications

General Coolant Information

NOTICE

Never add coolant to an overheated engine. Engine damage could result. Allow the engine to cool first.

NOTICE

If the engine is to be stored in, or shipped to an area with below freezing temperatures, the cooling system must be either protected to the lowest outside temperature or drained completely to prevent damage.

NOTICE

Frequently check the specific gravity of the coolant for proper freeze protection or for anti-boil protection.

Clean the cooling system for the following reasons:

- Contamination of the cooling system
 - Overheating of the engine
 - Foaming of the coolant
-

NOTICE

Never operate an engine without water temperature regulators in the cooling system. Water temperature regulators help to maintain the engine coolant at the proper operating temperature. Cooling system problems can develop without water temperature regulators.

Many engine failures are related to the cooling system. The following problems are related to cooling system failures: Overheating, leakage of the water pump, and plugged radiators or heat exchangers.

These failures can be avoided with correct cooling system maintenance. Cooling system maintenance is as important as maintenance of the fuel system and the lubrication system. Quality of the coolant is as important as the quality of the fuel and the lubricating oil.

Coolant is normally composed of three elements: Water, additives, and glycol.

Water

Water is used in the cooling system in order to transfer heat.

Distilled water or deionized water is recommended for use in engine cooling systems.

DO NOT use the following types of water in cooling systems: Hard water, softened water that has been conditioned with salt, and sea water.

If distilled water or deionized water is not available, use water with the properties that are listed in Table 7.

Table 7

Acceptable Water	
Property	Maximum Limit
Chloride (Cl)	40 mg/L
Sulfate (SO ₄)	100 mg/L
Total Hardness	170 mg/L
Total Solids	340 mg/L
Acidity	pH of 5.5 to 9.0

For a water analysis, consult one of the following sources:

- Local water utility company
- Agricultural agent
- Independent laboratory

Additives

Additives help to protect the metal surfaces of the cooling system. A lack of coolant additives or insufficient amounts of additives enable the following conditions to occur:

- Corrosion
- Formation of mineral deposits
- Rust
- Scale
- Foaming of the coolant

Many additives are depleted during engine operation. These additives must be replaced periodically.

Additives must be added at the correct concentration. Overconcentration of additives can cause the inhibitors to drop out-of-solution. The deposits can enable the following problems to occur:

- Formation of gel compounds
- Reduction of heat transfer
- Leakage of the water pump seal
- Plugging of radiators, coolers, and small passages

Glycol

Glycol in the coolant helps to provide protection against the following conditions:

- Boiling

- Freezing
- Cavitation of the water pump

For optimum performance, Perkins recommends a 1:1 mixture of a water/glycol solution.

Note: Use a mixture that will provide protection against the lowest ambient temperature.

Note: 100 percent pure glycol will freeze at a temperature of -23 °C (-9 °F).

Most conventional antifreezes use ethylene glycol. Propylene glycol may also be used. In a 1:1 mixture with water, ethylene and propylene glycol provide similar protection against freezing and boiling. See Tables 8 and 9.

Table 8

Ethylene Glycol		
Concentration	Freeze Protection	Boil Protection
50 Percent	-36 °C (-33 °F)	106 °C (223 °F)
60 Percent	-51 °C (-60 °F)	111 °C (232 °F)

NOTICE

Do not use propylene glycol in concentrations that exceed 50 percent glycol because of the reduced heat transfer capability of propylene glycol. Use ethylene glycol in conditions that require additional protection against boiling or freezing.

Table 9

Propylene Glycol		
Concentration	Freeze Protection	Anti-Boil Protection
50 Percent	-29 °C (-20 °F)	106 °C (223 °F)

To check the concentration of glycol in the coolant, measure the specific gravity of the coolant.

Coolant Recommendations

The following two coolants are used in Perkins diesel engines:

Preferred – Perkins Extended Life Coolant (ELC)

Acceptable – A commercial heavy-duty antifreeze that meets “ASTM D4985” specifications

NOTICE

Do not use a commercial coolant/antifreeze that only meets the ASTM D3306 specification. This type of coolant/antifreeze is made for light automotive applications.

Perkins recommends a 1:1 mixture of water and glycol. This mixture of water and glycol will provide optimum heavy-duty performance as an antifreeze. This ratio may be increased to 1:2 water to glycol if extra freezing protection is required.

Note: A commercial heavy-duty antifreeze that meets “ASTM D4985” specifications MAY require a treatment with an SCA at the initial fill. Read the label or the instructions that are provided by the OEM of the product.

In stationary engine applications and marine engine applications that do not require anti-boil protection or freeze protection, a mixture of SCA and water is acceptable. Perkins recommends a 6 percent to 8 percent concentration of SCA in those cooling systems. Distilled water or deionized water is preferred. Water which has the recommended properties may be used.

Engines that are operating in an ambient temperature above 43 °C (109.4 °F) must use SCA and water. Engines that operate in an ambient temperature above 43 °C (109.4 °F) and below 0 °C (32 °F) due to seasonal variations consult your Perkins dealer or your Perkins distributor for the correct level of protection.

Table 10

Coolant Service Life	
Coolant Type	Service Life
Perkins ELC	6,000 Service Hours or Three Years
Commercial Heavy-Duty Antifreeze that meets “ASTM D4985”	3000 Service Hours or Two Years
Perkins POWERPART SCA	3000 Service Hours or Two Years
Commercial SCA and Water	3000 Service Hours or Two Years

Extended Life Coolant (ELC)

Perkins provides Extended Life Coolant (ELC) for use in the following applications:

- Heavy-duty spark ignited gas engines
- Heavy-duty diesel engines

- Automotive applications

The anti-corrosion package for ELC is different from the anti-corrosion package for other coolants. ELC is an ethylene glycol base coolant. However, ELC contains organic corrosion inhibitors and antifoam agents with low amounts of nitrite. Perkins ELC has been formulated with the correct amount of these additives in order to provide superior corrosion protection for all metals in engine cooling systems.

ELC is available in a 1:1 premixed cooling solution with distilled water. The Premixed ELC provides freeze protection to -36 °C (-33 °F). The Premixed ELC is recommended for the initial fill of the cooling system. The Premixed ELC is also recommended for topping off the cooling system.

ELC Concentrate is also available. ELC Concentrate can be used to lower the freezing point to -51 °C (-60 °F) for arctic conditions.

Containers of several sizes are available. Consult your Perkins dealer or your Perkins distributor for the part numbers.

ELC Cooling System Maintenance**Correct additions to the Extended Life Coolant****NOTICE**

Use only Perkins products for pre-mixed or concentrated coolants.

Mixing Extended Life Coolant with other products reduces the Extended Life Coolant service life. Failure to follow the recommendations can reduce cooling system components life unless appropriate corrective action is performed.

In order to maintain the correct balance between the antifreeze and the additives, you must maintain the recommended concentration of Extended Life Coolant (ELC). Lowering the proportion of antifreeze lowers the proportion of additive. This will lower the ability of the coolant to protect the system from pitting, from cavitation, from erosion, and from deposits.

NOTICE

Do not use a conventional coolant to top-off a cooling system that is filled with Extended Life Coolant (ELC).

Do not use standard supplemental coolant additive (SCA).

When using Perkins ELC, do not use standard SCA's or SCA filters.

ELC Cooling System Cleaning

Note: If the cooling system is already using ELC, cleaning agents are not required to be used at the specified coolant change interval. Cleaning agents are only required if the system has been contaminated by the addition of some other type of coolant or by cooling system damage.

Clean water is the only cleaning agent that is required when ELC is drained from the cooling system.

After the cooling system is drained and after the cooling system is refilled, operate the engine while the cooling system filler cap is removed. Operate the engine until the coolant level reaches the normal operating temperature and until the coolant level stabilizes. As needed, add the coolant mixture in order to fill the system to the specified level.

Changing to Perkins ELC

To change from heavy-duty antifreeze to the Perkins ELC, perform the following steps:

NOTICE

Care must be taken to ensure that all fluids are contained during performance of inspection, maintenance, testing, adjusting and the repair of the product. Be prepared to collect the fluid with suitable containers before opening any compartment or disassembling any component containing fluids.

Dispose of all fluids according to local regulations and mandates.

1. Drain the coolant into a suitable container.
2. Dispose of the coolant according to local regulations.
3. Flush the system with clean water in order to remove any debris.
4. Use Perkins cleaner to clean the system. Follow the instruction on the label.
5. Drain the cleaner into a suitable container. Flush the cooling system with clean water.
6. Fill the cooling system with clean water and operate the engine until the engine is warmed to 49° to 66°C (120° to 150°F).

NOTICE

Incorrect or incomplete flushing of the cooling system can result in damage to copper and other metal components.

To avoid damage to the cooling system, make sure to completely flush the cooling system with clear water. Continue to flush the system until all the signs of the cleaning agent are gone.

7. Drain the cooling system into a suitable container and flush the cooling system with clean water.

Note: The cooling system cleaner must be thoroughly flushed from the cooling system. Cooling system cleaner that is left in the system will contaminate the coolant. The cleaner may also corrode the cooling system.

8. Repeat Steps 6 and 7 until the system is completely clean.
9. Fill the cooling system with the Perkins Premixed ELC.

ELC Cooling System Contamination

NOTICE

Mixing ELC with other products reduces the effectiveness of the ELC and shortens the ELC service life. Use only Perkins Products for premixed or concentrate coolants. Failure to follow these recommendations can result in shortened cooling system component life.

ELC cooling systems can withstand contamination to a maximum of ten percent of conventional heavy-duty antifreeze or SCA. If the contamination exceeds ten percent of the total system capacity, perform ONE of the following procedures:

- Drain the cooling system into a suitable container. Dispose of the coolant according to local regulations. Flush the system with clean water. Fill the system with the Perkins ELC.
- Drain a portion of the cooling system into a suitable container according to local regulations. Then, fill the cooling system with premixed ELC. This should lower the contamination to less than 10 percent.
- Maintain the system as a conventional Heavy-Duty Coolant. Treat the system with an SCA. Change the coolant at the interval that is recommended for the conventional Heavy-Duty Coolant.

Commercial Heavy-Duty Antifreeze and SCA

NOTICE

Commercial Heavy-Duty Coolant which contains Amine as part of the corrosion protection system must not be used.

NOTICE

Never operate an engine without water temperature regulators in the cooling system. Water temperature regulators help to maintain the engine coolant at the correct operating temperature. Cooling system problems can develop without water temperature regulators.

Check the antifreeze (glycol concentration) in order to ensure adequate protection against boiling or freezing. Perkins recommends the use of a refractometer for checking the glycol concentration.

Perkins engine cooling systems should be tested at 500 hour intervals for the concentration of Supplemental Coolant Additive (SCA).

Additions of SCA are based on the results of the test. An SCA that is liquid may be needed at 500 hour intervals.

Refer to Table 11 for part numbers and for quantities of SCA.

Table 11

Perkins Liquid SCA	
Part Number	Quantity
21825735	10

Adding the SCA to Heavy-Duty Coolant at the Initial Fill

Commercial heavy-duty antifreeze that meets "ASTM D4985" specifications MAY require an addition of SCA at the initial fill. Read the label or the instructions that are provided by the OEM of the product.

Use the equation that is in Table 12 to determine the amount of Perkins SCA that is required when the cooling system is initially filled.

Table 12

Equation For Adding The SCA To The Heavy-Duty Coolant At The Initial Fill
$V \times 0.045 = X$
V is the total volume of the cooling system.
X is the amount of SCA that is required.

Table 13 is an example for using the equation that is in Table 12.

Table 13

Example Of The Equation For Adding The SCA To The Heavy-Duty Coolant At The Initial Fill		
Total Volume of the Cooling System (V)	Multiplication Factor	Amount of SCA that is Required (X)
15 L (4 US gal)	$\times 0.045$	0.7 L (24 oz)

Adding The SCA to The Heavy-Duty Coolant For Maintenance

Heavy-duty antifreeze of all types REQUIRE periodic additions of an SCA.

Test the antifreeze periodically for the concentration of SCA. For the interval, refer to the Operation and Maintenance Manual, "Maintenance Interval Schedule" (Maintenance Section). Test the concentration of SCA.

Additions of SCA are based on the results of the test. The size of the cooling system determines the amount of SCA that is needed.

Use the equation that is in Table 14 to determine the amount of Perkins SCA that is required, if necessary:

Table 14

Equation For Adding The SCA To The Heavy-Duty Coolant For Maintenance
$V \times 0.014 = X$
V is the total volume of the cooling system.
X is the amount of SCA that is required.

Table 15 is an example for using the equation that is in Table 14.

Table 15

Example Of The Equation For Adding The SCA To The Heavy-Duty Coolant For Maintenance		
Total Volume of the Cooling System (V)	Multiplication Factor	Amount of SCA that is Required (X)
15 L (4 US gal)	$\times 0.014$	0.2 L (7 oz)

Cleaning the System of Heavy-Duty Antifreeze

Perkins cooling system cleaners are designed to clean the cooling system of harmful scale and corrosion. Perkins cooling system cleaners dissolve mineral scale, corrosion products, light oil contamination, and sludge.

- Clean the cooling system after used coolant is drained or before the cooling system is filled with new coolant.
- Clean the cooling system whenever the coolant is contaminated or whenever the coolant is foaming.

i04478614

Fluid Recommendations (Fuel Recommendations)

- **Glossary**
- ISO International Standards Organization
- ASTM American Society for Testing and Materials
- HFRR High Frequency Reciprocating Rig for Lubricity testing of diesel fuels
- FAME Fatty Acid Methyl Esters
- CFR Co-ordinating Fuel Research
- LSD Low Sulfur Diesel
- ULSD Ultra Low Sulfur Diesel
- RME Rape Methyl Ester
- SME Soy Methyl Ester
- EPA Environmental Protection Agency of the United States

General Information

NOTICE

Every attempt is made to provide accurate, up-to-date information. By use of this document you agree that Perkins Engines Company Limited is not responsible for errors or omissions.

NOTICE

These recommendations are subject to change without notice. Contact your local Perkins distributor for the most up-to-date recommendations.

Diesel Fuel Requirements

Perkins is not in a position to continuously evaluate and monitor all worldwide distillate diesel fuel specifications that are published by governments and technological societies.

Table 16 provides a known reliable baseline in order to judge the expected performance of distillate diesel fuels that are derived from conventional sources.

Satisfactory engine performance is dependent on the use of a good quality fuel. The use of a good quality fuel will give the following results: long engine life and acceptable exhaust emissions levels. The fuel must meet the minimum requirements that are stated in table 16.

NOTICE

The footnotes are a key part of the Perkins Specification for Distillate Diesel Fuel Table. Read ALL of the footnotes.

Table 16

Perkins Specification for Distillate Diesel Fuel ⁽¹⁾				
Property	UNITS	Requirements	“ASTM”Test	“ISO”Test
Aromatics	%Volume	35% maximum	D1319	“ISO”3837
Ash	%Weight	0.01% maximum	D482	“ISO”6245
Carbon Residue on 10% Bottoms	%Weight	0.35% maximum	D524	“ISO”4262
Cetane Number ⁽²⁾	-	40 minimum	D613/D6890	“ISO”5165
Cloud Point	°C	The cloud point must not exceed the lowest expected ambient temperature.	D2500	“ISO”3015
Copper Strip Corrosion	-	No. 3 maximum	D130	“ISO”2160
Density at 15 °C (59 °F) ⁽³⁾	Kg / M ³	801 minimum and 876 maximum	No equivalent test	“ISO 3675” “ISO 12185”
Distillation	°C	10% at 282 °C (539.6 °F) maximum 90% at 360 °C (680 °F) maximum	D86	“ISO”3405
Flash Point	°C	legal limit	D93	“ISO”2719
Thermal Stability	-	Minimum of 80% reflectance after aging for 180 minutes at 150 °C (302 °F)	D6468	No equivalent test
Pour Point	°C	6 °C (42.8 °F) minimum below ambient temperature	D97	“ISO”3016
Sulfur ⁽¹⁾⁽⁴⁾	%mass	1% maximum	D5453/D26222	“ISO 20846” “ISO 20884”
Kinematic Viscosity ⁽⁵⁾	“MM” ² /S (cSt)”	The viscosity of the fuel that is delivered to the fuel injection pump. “1.4 minimum/4.5 maximum”	D445	“ISO”3405
Water and sediment	% weight	0.1% maximum	D1796	“ISO”3734
Water	% weight	0.1% maximum	D6304	No equivalent test
Sediment	% weight	0.05% maximum	D473	“ISO”3735
Gums and Resins ⁽⁶⁾	mg/100mL	10 mg per 100 mL maximum	D381	“ISO”6246

(continued)

(Table 16, contd)

Lubricity corrected wear scar diameter at 60 °C (140 °F). ⁽⁷⁾	mm	0.46 maximum	D6079	"ISO"12156-1
--	----	--------------	-------	--------------

- (1) This specification includes the requirements for Ultra Low Sulfur Diesel (ULSD). ULSD fuel will have ≤ 15 ppm (0.0015%) sulfur. Refer to "ASTM D5453", "ASTM D2622", or "ISO 20846, ISO 20884" test methods. This specification includes the requirements for Low Sulfur Diesel (LSD). LSD fuel will have ≤ 500 ppm (0.05%) sulfur. Refer to following: "ASTM 5453, ASTM D2622", "ISO 20846", and "ISO 20884 test methods".
- (2) A fuel with a higher cetane number is recommended in order to operate at a higher altitude or in cold weather.
- (3) "Via standards tables, the equivalent API gravity for the minimum density of 801 kg / m³ (kilograms per cubic meter) is 45 and for the maximum density of 876 kg / m³ is 30".
- (4) Regional regulations, national regulations, or international regulations can require a fuel with a specific sulfur limit. Consult all applicable regulations before selecting a fuel for a given engine application. Perkins fuel systems and engine components can operate on high sulfur fuels. Fuel sulfur levels affect exhaust emissions. High sulfur fuels also increase the potential for corrosion of internal components. Fuel sulfur levels above 0.5% may significantly shorten the oil change interval. For additional information, refer to this manual, "Fluid recommendations (General lubricant Information)".
- (5) The values of the fuel viscosity are the values as the fuel is delivered to the fuel injection pumps. Fuel should also meet the minimum viscosity requirement and the fuel should meet the maximum viscosity requirements at 40 °C (104 °F) of either the "ASTM D445" test method or the "ISO 3104" test method. If a fuel with a low viscosity is used, cooling of the fuel may be required to maintain 1.4 cSt or greater viscosity at the fuel injection pump. Fuels with a high viscosity might require fuel heaters in order to lower the viscosity to 4.5 cSt at the fuel injection pump.
- (6) Follow the test conditions and procedures for gasoline (motor).
- (7) The lubricity of a fuel is a concern with low sulfur and ultra low sulfur fuel. To determine the lubricity of the fuel, use the "ISO 12156-1 or ASTM D6079 High Frequency Reciprocating Rig (HFRR)" test. If the lubricity of a fuel does not meet the minimum requirements, consult your fuel supplier. Do not treat the fuel without consulting the fuel supplier. Some additives are not compatible. These additives can cause problems in the fuel system.

NOTICE

Operating with fuels that do not meet the Perkins recommendations can cause the following effects: Starting difficulty, poor combustion, deposits in the fuel injectors, reduced service life of the fuel system, deposits in the combustion chamber, and reduced service life of the engine.

Engines that are manufactured by Perkins are certified with the fuel that is prescribed by the United States Environmental Protection Agency. Engines that are manufactured by Perkins are certified with the fuel that is prescribed by the European Certification and other regulatory agencies. Perkins does not certify diesel engines on any other fuel.

Note: The owner and the operator of the engine has the responsibility of using the fuel that is prescribed by the Environmental Protection Agency (EPA) and other appropriate regulatory agencies.

Diesel Fuel Characteristics

Perkins Recommendations

Cetane Number

Fuel that has a high cetane number will give a shorter ignition delay. This will produce a better ignition quality. Cetane numbers are derived for fuels against proportions of cetane and heptamethylnonane in the standard CFR engine. Refer to "ISO 5165" for the test method.

Cetane numbers in excess of 45 are normally expected from current diesel fuel. However, a cetane number of 40 may be experienced in some territories. The United States of America is one of the territories that can have a low cetane value. A minimum cetane value of 40 is required during average starting conditions. A higher cetane value may be required for operations at high altitudes or in cold-weather operations.

Fuel with a low cetane number can be the root cause of problems during cold start.

Viscosity

Viscosity is the property of a liquid of offering resistance to shear or flow. Viscosity decreases with increasing temperature. This decrease in viscosity follows a logarithmic relationship for normal fossil fuel. The common reference is to kinematic viscosity. This is the quotient of the dynamic viscosity that is divided by the density. The determination of kinematic viscosity is normally by readings from gravity flow viscometers at standard temperatures. Refer to "ISO 3104" for the test method.

The viscosity of the fuel is significant because fuel serves as a lubricant for the fuel system components. Fuel must have sufficient viscosity in order to lubricate the fuel system in both cold temperatures and hot temperatures. If the kinematic viscosity of the fuel is lower than 1.4 cSt at the fuel injection pump damage to the fuel injection pump can occur. This damage can be excessive scuffing and seizure. Low viscosity may lead to difficult hot restarting, stalling, and loss of performance. High viscosity may result in seizure of the pump.

Perkins recommends kinematic viscosities of 1.4 and 4.5 cSt that is delivered to the fuel injection pump. If a fuel with a low viscosity is used, cooling of the fuel may be required to maintain 1.4 cSt or greater viscosity at the fuel injection pump. Fuels with a high viscosity might require fuel heaters in order to lower the viscosity to 4.5 cSt at the fuel injection pump.

Density

Density is the mass of the fuel per unit volume at a specific temperature. This parameter has a direct influence on engine performance and a direct influence on emissions. This determines the heat output from a given injected volume of fuel. This is quoted in the following kg/m³ at 15 °C (59 °F).

Perkins recommends a value of density of 841 kg/m³ in order to obtain the correct power output. Lighter fuels are acceptable but these fuels will not produce the rated power.

Sulfur

The level of sulfur is governed by emissions legislations. Regional regulation, national regulations, or international regulations can require a fuel with a specific sulfur limit. The sulfur content of the fuel and the fuel quality must comply with all existing local regulations for emissions.

In some parts of the world and for some applications, high sulfur fuels above 0.5% by mass might only be available. Fuel with a high sulfur content can cause engine wear. High sulfur fuel will have a negative impact on emissions of particulates. High sulfur fuel can be used if the local emissions legislation will allow the use. High sulfur fuel can be used in countries that do not regulate emissions.

When only high sulfur fuels are available, it will be necessary that high alkaline lubricating oil is used in the engine or that the lubricating oil change interval is reduced. Refer to Operation and Maintenance Manual, "Fluid Recommendations (Lubricant Information)" for information on sulfur in fuel.

Lubricity

This is the capability of the fuel to prevent pump wear. The lubricity of the fluid describes the ability of the fluid to reduce the friction between surfaces that are under load. This ability reduces the damage that is caused by friction. Fuel injection systems rely on the lubricating properties of the fuel. Until fuel sulfur limits were mandated, the lubricity of the fuel was believed to be a function of fuel viscosity.

The lubricity has particular significance to the current low viscosity fuel, low sulfur fuel, and low aromatic fossil fuel. These fuels are made in order to meet stringent exhaust emissions.

The lubricity of these fuels must not exceed wear scar diameter of 0.46 mm (0.01811 inch). The fuel lubricity test must be performed on an HFRR, operated at 60 °C (140 °F). Refer to "ISO 12156-1".

NOTICE

The fuels system has been qualified with fuel having lubricity up to 0.46 mm (0.01811 inch) wear scar diameter as tested by "ISO 12156-1". Fuel with higher wear scar diameter than 0.46 mm (0.01811 inch) will lead to reduced service life and premature failure of the fuel system.

In case of the fuels which do not meet specified lubricity requirement appropriate lubricity additive can be used to enhance the lubricity of the fuel.

Contact your fuel supplier for those circumstances when fuel additives are required. Your fuel supplier can make recommendations for additives to use and for the proper level of treatment.

Distillation

This is an indication of the mixture of different hydrocarbons in the fuel. A high ratio of light weight hydrocarbons can affect the characteristics of combustion.

Classification of the Fuels

Diesel engines have the ability to burn wide variety of fuels. Below is a list of typically encountered fuel specifications that have been assessed as to their acceptability and are divided into following categories:

Group 1: Preferred Fuels

The following fuel specifications are considered acceptable.

Fuels meeting the requirements that are listed in the table 16.

"EN590 - Grades A to F and class 0 to 4"

"ASTM D975 Grade No. 1-D and 2-D"

"JIS K2204 Grades 1, 2 & 3 & Special Grade 3" acceptable provided lubricity wear scar diameter does not exceed of 0.46 mm (0.01811 inch) as per "ISO 12156-1".

"BS2869 - Class A2 Off Highway Gas Oil, Red Diesel"

Note: The lubricity of these fuels must not exceed wear scar diameter of 0.46 mm (0.01811 inch) as per “ISO 12156-1”. Refer to “Lubricity”.

Group 2: Aviation Kerosene Fuels

Following kerosene and jet fuel specifications are acceptable alternative fuels and may be used on a contingency bases for emergency or continuous use, where standard diesel fuel is not available and where legislation allows their use:

“MIL-DTL-83133 NATO F34 (JP-8)”

“MIL-DTL-83133 NATO F35”

“MIL-DTL-5624 NATO F44 (JP-5)”

“MIL-DTL-38219 (USAF) (JP7)”

“NATO XF63”

“ASTM D1655 JET A”

“ASTM D1655 JET A1”

NOTICE

These fuels are only acceptable when used with appropriate lubricity additive and must meet minimum requirements that are listed in table 16. The lubricity of these fuels must not exceed wear scar diameter of 0.46 mm (0.01811 inch) as per “ISO 12156-1”. Refer to “Lubricity”.

Note: Minimum cetane number of 40 is recommended otherwise cold starting problems or light load misfire might occur. Since jet fuel specifications do not mention cetane requirements, Perkins recommends that a fuel sample is taken to determine the cetane number.

Note: Fuels must have minimum viscosity of 1.4 cSt delivered to the fuel injection pump. Cooling of the fuel may be required to maintain 1.4 cSt or greater viscosity at the fuel injection pump. Perkins recommends that the actual viscosity of the fuel be measured in order to determine if a fuel cooler is needed. Refer to “Viscosity”.

Note: Rated power loss of up to 10 percent is possible due to lower density and lower viscosity of jet fuels compared to diesel fuels.

Biodiesel Fuel

Biodiesel is a fuel that can be defined as mono-alkyl esters of fatty acids. Biodiesel is a fuel that can be made from various feedstock. The most commonly available biodiesel in Europe is Rape Methyl Ester (REM). This biodiesel is derived from rapeseed oil. Soy Methyl Ester (SME) is the most common biodiesel in the United States. This biodiesel is derived from soybean oil. Soybean oil or rapeseed oil are the primary feedstocks. These fuels are together known as Fatty Acid Methyl Esters (FAME).

Raw pressed vegetable oils are NOT acceptable for use as a fuel in any concentration in compression engines. Without esterification, these oils gel in the crankcase and the fuel tank. These fuels may not be compatible with many of the elastomers that are used in engines that are manufactured today. In original forms, these oils are not suitable for use as a fuel in compression engines. Alternate base stocks for biodiesel may include animal tallow, waste cooking oils, or various other feedstocks. In order to use any of the products that are listed as fuel, the oil must be esterified.

Fuel made of 100 percent FAME is generally referred to as B100 biodiesel or neat biodiesel.

Biodiesel can be blended with distillate diesel fuel. The blends can be used as fuel. The most commonly available biodiesel blends are B5, which is 5 percent biodiesel and 95 percent distillate diesel fuel. B20, which is 20 percent biodiesel and 80 percent distillate diesel fuel.

Note: The percentages given are volume-based. The U.S. distillate diesel fuel specification “ASTM D975-09a” includes up to B5 (5 percent) biodiesel.

European distillate diesel fuel specification “EN590:2010” includes up to B7 (7 percent) biodiesel.

Note: Engines that are manufactured by Perkins are certified by use of the prescribed Environmental Protection Agency (EPA) and European Certification fuels. Perkins does not certify engines on any other fuel. The user of the engine has the responsibility of using the correct fuel that is recommended by the manufacturer and allowed by the EPA and other appropriate regulatory agencies.

Specification Requirements

The neat biodiesel must conform to “EN14214” or “ASTM D6751” (in the USA) and can only be blended in mixture of up to 20 percent by volume in acceptable mineral diesel fuel meeting requirements that are listed in table 16 or the latest edition of “EN590” and “ASTM D 975” commercial standards. This blend is commonly known as B20.

Biodiesel blends are denoted as “BXX” with “XX” representing the content of neat biodiesel contained in the blend with mineral diesel fuel (for example B5, B10, B20).

In United States Biodiesel blends of B6 to B20 must meet the requirements listed in the latest edition of “ASTM D7467” (B6 to B20) and must be of an API gravity of 30-45.

In North America biodiesel and biodiesel blends must be purchased from the BQ-9000 accredited producers and BQ-9000 certified distributors.

In other areas of the world, the use of biodiesel that is BQ-9000 accredited and certified, or that is accredited and certified by a comparable biodiesel quality body to meet similar biodiesel quality standards is required.

Engine Service Requirements with B20

Aggressive properties of biodiesel fuel may cause debris in the fuel tank and fuel lines. The aggressive properties of biodiesel will clean the fuel tank and fuel lines. This cleaning of the fuel system can prematurely block of the fuel filters. Perkins recommends that after the initial usage of B20 biodiesel blended fuel the fuel filters must be replaced at 50 hours.

Glycerides present in biodiesel fuel will also cause fuel filters to become blocked more quickly. Therefore the regular service interval should be reduced to 250 hours.

When biodiesel fuel is used, crank case oil and aftertreatment systems may be influenced. This influence is due to the chemical composition and characteristics of biodiesel fuel, such as density and volatility, and to chemical contaminants that can be present in this fuel, such as alkali and alkaline metals (sodium, potassium, calcium, and magnesium).

- Crankcase oil fuel dilution can be higher when biodiesel or biodiesel blends are used. This increased level of fuel dilution when using biodiesel or biodiesel blends is related to the typically lower volatility of biodiesel. In-cylinder emissions control strategies utilized in many of the industrial latest engine designs may lead to a higher level of biodiesel concentration in the engine oil pan. The long-term effect of biodiesel concentration in crankcase oil is currently unknown.
- Perkins recommends the use of oil analysis in order to check the quality of the engine oil if biodiesel fuel is used. Ensure that the level of biodiesel in the fuel is noted when the oil sample is taken.

Performance Related Issues with B20

Due to the lower energy content than the standard distillate fuel B20 will cause a power loss in order of 2 to 4 percent. In addition, over time the power may deteriorate further due to deposits in the fuel injectors.

Biodiesel and biodiesel blends are known to cause an increase in fuel system deposits, most significant of which are deposits within the fuel injector. These deposits can cause a loss in power due to restricted or modified fuel injection or cause other functional issues associated with these deposits.

Note: Perkins T400012 Fuel Cleaner is most effective in cleaning and preventing the formation of deposits. Perkins Diesel Fuel Conditioner helps to limit deposit issues by improving the stability of biodiesel and biodiesel blends. Refer to “Perkins Diesel Fuel System Cleaner” for more information.

General Requirements

Biodiesel has poor oxidation stability, which can result in long-term problems in the storage of biodiesel. Biodiesel fuel should be used within 6 months of manufacture. Equipment should not be stored with the B20 biodiesel blends in the fuel system for longer than 3 months.

Due to poor oxidation stability and other potential issues, it is strongly recommended that engines with limited operational time either not use B20 biodiesel blends or, while accepting some risk, limit biodiesel blend to a maximum of B5. Examples of applications that should limit the use of biodiesel are the following: Standby generator sets and certain emergency vehicles.

Perkins strongly recommends that seasonally operated engines have the fuel systems, including fuel tanks, flashed with conventional diesel fuel before prolonged shutdown periods. An example of an application that should seasonally flush the fuel system is a combine harvester.

Microbial contamination and growth can cause corrosion in the fuel system and premature plugging of the fuel filter. Consult your supplier of fuel for assistance in selecting appropriate antimicrobial additive.

Water accelerates microbial contamination and growth. When biodiesel is compared to distillate fuels, water is naturally more likely to exist in the biodiesel. It is therefore essential to check frequently and if necessary, drain the water separator.

Materials such as brass, bronze, copper, lead, tin, and zinc accelerate the oxidation process of the biodiesel fuel. The oxidation process can cause deposits formation therefore these materials must not be used for fuel tanks and fuel lines.

Fuel for Cold Weather Operation

The European standard "EN590" contains climate dependant requirements and a range of options. The options can be applied differently in each country. There are five classes that are given to arctic climates and severe winter climates. 0, 1, 2, 3, and 4.

Fuel that complies with "EN590" CLASS 4 can be used at temperatures as low as $-44\text{ }^{\circ}\text{C}$ ($-47.2\text{ }^{\circ}\text{F}$). Refer to "EN590" for a detailed discretion of the physical properties of the fuel.

The diesel fuel "ASTM D975 1-D" that is used in the United States of America may be used in cold temperatures that are below $-18\text{ }^{\circ}\text{C}$ ($-0.4\text{ }^{\circ}\text{F}$).

In extreme cold ambient conditions, you may use the aviation kerosene fuels that are specified in "Classification of the Fuels". These fuels are intended to be used in temperatures that can be as low as $-54\text{ }^{\circ}\text{C}$ ($-65.2\text{ }^{\circ}\text{F}$). Refer to "Classification of the Fuels" for detail and conditions of use of the aviation kerosene fuels.

WARNING

Mixing alcohol or gasoline with diesel fuel can produce an explosive mixture in the engine crankcase or the fuel tank. Alcohol or gasoline must not be used in order to dilute diesel fuel. Failure to follow this instruction may result in death or personal injury.

There are many other diesel fuel specifications that are published by governments and by technological societies. Usually, those specifications do not review all the requirements that are addressed in table 16. To ensure optimum engine performance, a complete fuel analysis should be obtained before engine operation. The fuel analysis should include all of the properties that are stated in the table 16.

Aftermarket Fuel Additives

NOTICE

Perkins does not warrant the quality or performance of non Perkins fluids and filters.

When auxiliary devices, accessories, or consumables (filters, additives) which are made by other manufacturers are used on Perkins products, the Perkins warranty is not affected simply because of such use.

However, failures that result from the installation or use of other manufacturers devices, accessories, or consumables are NOT Perkins defects. Therefore, the defects are NOT covered under the Perkins warranty.

Supplemental diesel fuel additives are not recommended. This is due to potential damage to the fuel system or the engine. Your fuel supplier or the fuel manufacturer will add the appropriate supplemental diesel fuel additives.

Perkins recognizes the fact that additives may be required in some special circumstances. Fuel additives need to be used with caution. Contact your fuel supplier for those circumstances when fuel additives are required. Your fuel supplier can recommend the appropriate fuel additive and the correct level of treatment.

Note: For the best results, your fuel supplier should treat the fuel when additives are required. The treated fuel must meet the requirements that are stated in table 16.

Perkins Diesel Fuel System Cleaner

Perkins T400012 Fuel Cleaner is the only fuel cleaner that is recommended by Perkins.

If biodiesel or biodiesel blends of fuel are to be used, Perkins require the use of Perkins fuel cleaner. For more information on the use of biodiesel and biodiesel blends refer to "Biodiesel Fuel".

Perkins fuel cleaner will remove deposits that can form in the fuel system with the use of biodiesel and biodiesel blends. These deposits can create a loss of power and engine performance.

Once the fuel cleaner has been added to the fuel, the deposits within the fuel system are removed after 30 hours of engine operation. For maximum results, continue to use the fuel cleaner for up to 80 hours. Perkins fuel cleaner can be used on an on-going basis with no adverse impact on engine or fuel system durability.

Detailed instructions on the rate of which the fuel cleaner must be use are on the container.

i04431375

Maintenance Interval Schedule

When Required

Battery - Replace	52
Battery or Battery Cable - Disconnect	53
Engine - Clean	59
Engine Air Cleaner Element (Dual Element) - Clean/Replace	60
Engine Air Cleaner Element (Single Element) - Inspect/Replace	62
Fuel System - Prime	68
Severe Service Application - Check	74

Daily

Cooling System Coolant Level - Check	57
Driven Equipment - Check	59
Engine Air Cleaner Service Indicator - Inspect	62
Engine Air Precleaner - Check/Clean	63
Engine Oil Level - Check	64
Fuel System Primary Filter/Water Separator - Drain	69
V-Belts - Inspect/Adjust/Replace	76
Walk-Around Inspection	77

Every 50 Service Hours or Weekly

Fuel Tank Water and Sediment - Drain	72
--	----

Every 500 Service Hours

V-Belts - Inspect/Adjust/Replace	76
--	----

Every 500 Service Hours or 1 Year

Battery Electrolyte Level - Check	53
Cooling System Supplemental Coolant Additive (SCA) - Test/Add	58
Crankcase Breather (Canister) - Replace	59
Engine Air Cleaner Element (Dual Element) - Clean/Replace	60
Engine Oil and Filter - Change	64
Fuel System Primary Filter (Water Separator) Element - Replace	68
Fuel System Secondary Filter - Replace	70
Hoses and Clamps - Inspect/Replace	73
Radiator - Clean	74

Every 1000 Service Hours

Engine Valve Lash - Inspect/Adjust	66
--	----

Every 2000 Service Hours

Aftercooler Core - Inspect	51
Alternator - Inspect	52
Engine Mounts - Inspect	63
Starting Motor - Inspect	75

Turbocharger - Inspect	75
Water Pump - Inspect	78

Every 3000 Service Hours

Alternator Belt - Inspect/Adjust/Replace	52
Fuel Injector - Test/Change	67

Every 3000 Service Hours or 2 Years

Cooling System Coolant (Commercial Heavy-Duty) - Change	54
--	----

Every 4000 Service Hours

Aftercooler Core - Clean/Test	51
-------------------------------------	----

Every 12 000 Service Hours or 6 Years

Cooling System Coolant (ELC) - Change	55
---	----

i02690449

Aftercooler Core - Clean/Test

1. Remove the core. Refer to the OEM information for the correct procedure.
2. Turn the aftercooler core upside-down in order to remove debris.

WARNING

Personal injury can result from air pressure.

Personal injury can result without following proper procedure. When using pressure air, wear a protective face shield and protective clothing.

Maximum air pressure at the nozzle must be less than 205 kPa (30 psi) for cleaning purposes.

3. Pressurized air is the preferred method for removing loose debris. Direct the air in the opposite direction of the fan's air flow. Hold the nozzle approximately 6 mm (.25 inch) away from the fins. Slowly move the air nozzle in a direction that is parallel with the tubes. This will remove debris that is between the tubes.
4. Pressurized water may also be used for cleaning. The maximum water pressure for cleaning purposes must be less than 275 kPa (40 psi). Use pressurized water in order to soften mud. Clean the core from both sides.

NOTICE

Do not use a high concentration of caustic cleaner to clean the core. A high concentration of caustic cleaner can attack the internal metals of the core and cause leakage. Only use the recommended concentration of cleaner.

5. Back flush the core with a suitable cleaner.
6. Steam clean the core in order to remove any residue. Flush the fins of the aftercooler core. Remove any other trapped debris.
7. Wash the core with hot, soapy water. Rinse the core thoroughly with clean water.

WARNING

Personal injury can result from air pressure.

Personal injury can result without following proper procedure. When using pressure air, wear a protective face shield and protective clothing.

Maximum air pressure at the nozzle must be less than 205 kPa (30 psi) for cleaning purposes.

8. Dry the core with compressed air. Direct the air in the reverse direction of the normal flow.
9. Inspect the core in order to ensure cleanliness. Pressure test the core. If necessary, repair the core.
10. Install the core. Refer to the OEM information for the correct procedure.
11. After cleaning, start the engine and accelerate the engine to high idle rpm. This will help in the removal of debris and drying of the core. Stop the engine. Use a light bulb behind the core in order to inspect the core for cleanliness. Repeat the cleaning, if necessary.

i02690450

Aftercooler Core - Inspect

Note: Adjust the frequency of cleaning according to the effects of the operating environment.

Inspect the aftercooler for these items: damaged fins, corrosion, dirt, grease, insects, leaves, oil, and other debris. Clean the aftercooler, if necessary.

For air-to-air aftercoolers, use the same methods that are used for cleaning radiators.

WARNING

Personal injury can result from air pressure.

Personal injury can result without following proper procedure. When using pressure air, wear a protective face shield and protective clothing.

Maximum air pressure at the nozzle must be less than 205 kPa (30 psi) for cleaning purposes.

After cleaning, start the engine and accelerate the engine to high idle rpm. This will help in the removal of debris and drying of the core. Stop the engine. Use a light bulb behind the core in order to inspect the core for cleanliness. Repeat the cleaning, if necessary.

Inspect the fins for damage. Bent fins may be opened with a "comb".

Note: If parts of the aftercooler system are repaired or replaced, a leak test is highly recommended.

Inspect these items for good condition: Welds, mounting brackets, air lines, connections, clamps, and seals. Make repairs, if necessary.

i02674959

Alternator - Inspect

Perkins recommends a scheduled inspection of the alternator. Inspect the alternator for loose connections and correct battery charging. Inspect the ammeter (if equipped) during engine operation in order to ensure correct battery performance and/or correct performance of the electrical system. Make repairs, as required.

Check the alternator and the battery charger for correct operation. If the batteries are correctly charged, the ammeter reading should be very near zero. All batteries should be kept charged. The batteries should be kept warm because temperature affects the cranking power. If the battery is too cold, the battery will not crank the engine. When the engine is not run for long periods of time or if the engine is run for short periods, the batteries may not fully charge. A battery with a low charge will freeze more easily than a battery with a full charge.

i02690445

Alternator Belt - Inspect/Adjust/Replace (Poly V-Belt)

Inspection

To maximize the engine performance, inspect the belt (1) for wear and for cracking. Replace the belt if the belt is worn or damaged.

- If the belt (1) has more than four cracks per 25.4000 mm (1 inch) the belt must be replaced.

- Check the belt of cracks, splits, glazing, grease, and splitting.

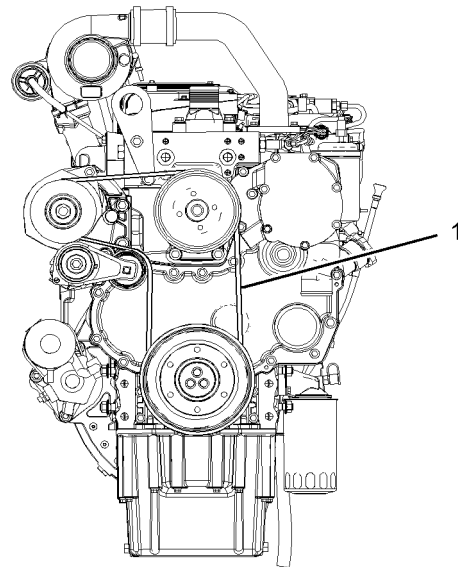

Illustration 19

g01251375

Typical example

Adjustment

This type of belt has an automatic belt tensioner.

Replace

Refer to Disassembly and Assembly manual, "Alternator Belt - Remove and Install".

i02675026

Battery - Replace

WARNING

Batteries give off combustible gases which can explode. A spark can cause the combustible gases to ignite. This can result in severe personal injury or death.

Ensure proper ventilation for batteries that are in an enclosure. Follow the proper procedures in order to help prevent electrical arcs and/or sparks near batteries. Do not smoke when batteries are serviced.

⚠ WARNING

The battery cables or the batteries should not be removed with the battery cover in place. The battery cover should be removed before any servicing is attempted.

Removing the battery cables or the batteries with the cover in place may cause a battery explosion resulting in personal injury.

1. Switch the engine to the OFF position. Remove all electrical loads.
2. Turn off any battery chargers. Disconnect any battery chargers.
3. The NEGATIVE “-” cable connects the NEGATIVE “-” battery terminal to the NEGATIVE “-” terminal on the starting motor. Disconnect the cable from the NEGATIVE “-” battery terminal.
4. The POSITIVE “+” cable connects the POSITIVE “+” battery terminal to the POSITIVE “+” terminal on the starting motor. Disconnect the cable from the POSITIVE “+” battery terminal.

Note: Always recycle a battery. Never discard a battery. Return used batteries to an appropriate recycling facility.

5. Remove the used battery.
6. Install the new battery.

Note: Before the cables are connected, ensure that the engine start switch is OFF.

7. Connect the cable from the starting motor to the POSITIVE “+” battery terminal.
8. Connect the cable from the NEGATIVE “-” terminal on the starting motor to the NEGATIVE “-” battery terminal.

i02674900

Battery Electrolyte Level - Check

When the engine is not run for long periods of time or when the engine is run for short periods, the batteries may not fully recharge. Ensure a full charge in order to help prevent the battery from freezing. If batteries are correctly charged, the ammeter reading should be very near zero, when the engine is in operation.

⚠ WARNING

All lead-acid batteries contain sulfuric acid which can burn the skin and clothing. Always wear a face shield and protective clothing when working on or near batteries.

1. Remove the filler caps. Maintain the electrolyte level to the “FULL” mark on the battery.

If the addition of water is necessary, use distilled water. If distilled water is not available use clean water that is low in minerals. Do not use artificially softened water.

2. Check the condition of the electrolyte with a suitable battery tester.
3. Install the caps.
4. Keep the batteries clean.

Clean the battery case with one of the following cleaning solutions:

- A mixture of 0.1 kg (0.2 lb) of washing soda or baking soda and 1 L (1 qt) of clean water
- A mixture of 0.1 L (0.11 qt) of ammonia and 1 L (1 qt) of clean water

Thoroughly rinse the battery case with clean water.

i02675127

Battery or Battery Cable - Disconnect

⚠ WARNING

The battery cables or the batteries should not be removed with the battery cover in place. The battery cover should be removed before any servicing is attempted.

Removing the battery cables or the batteries with the cover in place may cause a battery explosion resulting in personal injury.

1. Turn the start switch to the OFF position. Turn the ignition switch (if equipped) to the OFF position and remove the key and all electrical loads.
2. Disconnect the negative battery terminal. Ensure that the cable cannot contact the terminal. When four 12 volt batteries are involved, two negative connection must be disconnected.

3. Remove the positive connection.
4. Clean all disconnected connection and battery terminals.
5. Use a fine grade of sandpaper to clean the terminals and the cable clamps. Clean the items until the surfaces are bright or shiny. DO NOT remove material excessively. Excessive removal of material can cause the clamps to not fit correctly. Coat the clamps and the terminals with a suitable silicone lubricant or petroleum jelly.
6. Tape the cable connections in order to help prevent accidental starting.
7. Proceed with necessary system repairs.
8. In order to connect the battery, connect the positive connection before the negative connector.

i02675519

Cooling System Coolant (Commercial Heavy-Duty) - Change

NOTICE

Care must be taken to ensure that fluids are contained during performance of inspection, maintenance, testing, adjusting and repair of the product. Be prepared to collect the fluid with suitable containers before opening any compartment or disassembling any component containing fluids.

Dispose of all fluids according to Local regulations and mandates.

NOTICE

Keep all parts clean from contaminants.

Contaminants may cause rapid wear and shortened component life.

Clean the cooling system and flush the cooling system before the recommended maintenance interval if the following conditions exist:

- The engine overheats frequently.
- Foaming is observed.
- The oil has entered the cooling system and the coolant is contaminated.

- The fuel has entered the cooling system and the coolant is contaminated.

Note: When the cooling system is cleaned, only clean water is needed.

Note: Inspect the water pump and the water temperature regulator after the cooling system has been drained. This is a good opportunity to replace the water pump, the water temperature regulator and the hoses, if necessary.

Drain

WARNING

Pressurized System: Hot coolant can cause serious burns. To open the cooling system filler cap, stop the engine and wait until the cooling system components are cool. Loosen the cooling system pressure cap slowly in order to relieve the pressure.

1. Stop the engine and allow the engine to cool. Loosen the cooling system filler cap slowly in order to relieve any pressure. Remove the cooling system filler cap.

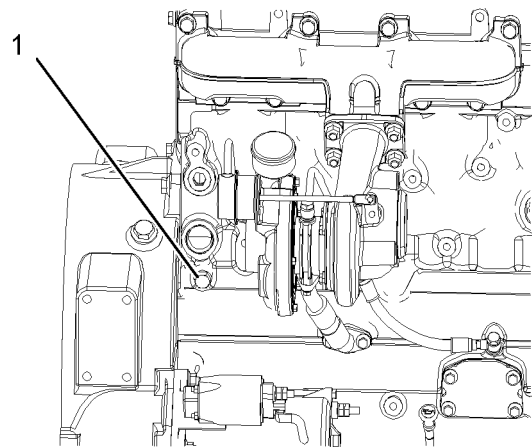

Illustration 20

g01356026

2. Open the drain cock or remove the drain plug (1) on the engine. Open the drain cock or remove the drain plug on the radiator.

Allow the coolant to drain.

NOTICE

Dispose of used engine coolant or recycle. Various methods have been proposed to reclaim used coolant for reuse in engine cooling systems. The full distillation procedure is the only method acceptable by Perkins to reclaim the coolant.

For information regarding the disposal and the recycling of used coolant, consult your Perkins dealer or your Perkins distributor.

Flush

1. Flush the cooling system with clean water in order to remove any debris.
 2. Close the drain cock or install the drain plug in the engine. Close the drain cock or install the drain plug on the radiator.
-

NOTICE

Do not fill the cooling system faster than 5 L (1.3 US gal) per minute to avoid air locks.

Cooling system air locks may result in engine damage.

3. Fill the cooling system with clean water. Install the cooling system filler cap.
4. Start and run the engine at low idle until the temperature reaches 49 to 66 °C (120 to 150 °F).
5. Stop the engine and allow the engine to cool. Loosen the cooling system filler cap slowly in order to relieve any pressure. Remove the cooling system filler cap. Open the drain cock or remove the drain plug on the engine. Open the drain cock or remove the drain plug on the radiator. Allow the water to drain. Flush the cooling system with clean water.

Fill

1. Close the drain cock or install the drain plug on the engine. Close the drain cock or install the drain plug on the radiator.
-

NOTICE

Do not fill the cooling system faster than 5 L (1.3 US gal) per minute to avoid air locks.

Cooling system air locks may result in engine damage.

2. Fill the cooling system with Commercial Heavy-Duty Coolant. Add Supplemental Coolant Additive to the coolant. For the correct amount, refer to the Operation and Maintenance Manual, "Fluid Recommendations" topic (Maintenance Section) for more information on cooling system specifications. Do not install the cooling system filler cap.
3. Start and run the engine at low idle. Increase the engine rpm to high idle. Run the engine at high idle for one minute in order to purge the air from the cavities of the engine block. Stop the engine.
4. Check the coolant level. Maintain the coolant level within 13 mm (0.5 inch) below the bottom of the pipe for filling. Maintain the coolant level in the expansion bottle (if equipped) at the correct level.
5. Clean the cooling system filler cap. Inspect the gasket that is on the cooling system filler cap. If the gasket that is on the cooling system filler cap is damaged, discard the old cooling system filler cap and install a new cooling system filler cap. If the gasket that is on the cooling system filler cap is not damaged, use a suitable pressurizing pump in order to pressure test the cooling system filler cap. The correct pressure for the cooling system filler cap is stamped on the face of the cooling system filler cap. If the cooling system filler cap does not retain the correct pressure, install a new cooling system filler cap.
6. Start the engine. Inspect the cooling system for leaks and for correct operating temperature.

i02675568

**Cooling System Coolant (ELC)
- Change**

NOTICE

Care must be taken to ensure that fluids are contained during performance of inspection, maintenance, testing, adjusting and repair of the product. Be prepared to collect the fluid with suitable containers before opening any compartment or disassembling any component containing fluids.

Dispose of all fluids according to Local regulations and mandates.

NOTICE

Keep all parts clean from contaminants.

Contaminants may cause rapid wear and shortened component life.

Clean the cooling system and flush the cooling system before the recommended maintenance interval if the following conditions exist:

- The engine overheats frequently.
- Foaming is observed.
- The oil has entered the cooling system and the coolant is contaminated.
- The fuel has entered the cooling system and the coolant is contaminated.

Note: When the cooling system is cleaned, only clean water is needed when the ELC is drained and replaced.

Note: Inspect the water pump and the water temperature regulator after the cooling system has been drained. This is a good opportunity to replace the water pump, the water temperature regulator and the hoses, if necessary.

Drain

WARNING

Pressurized System: Hot coolant can cause serious burns. To open the cooling system filler cap, stop the engine and wait until the cooling system components are cool. Loosen the cooling system pressure cap slowly in order to relieve the pressure.

1. Stop the engine and allow the engine to cool. Loosen the cooling system filler cap slowly in order to relieve any pressure. Remove the cooling system filler cap.

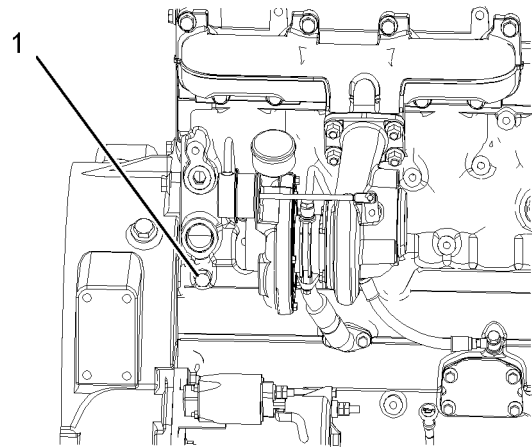

Illustration 21
Typical example

g01356026

2. Open the drain cock or remove the drain plug (1) on the engine. Open the drain cock or remove the drain plug on the radiator.

Allow the coolant to drain.

NOTICE

Dispose of used engine coolant or recycle. Various methods have been proposed to reclaim used coolant for reuse in engine cooling systems. The full distillation procedure is the only method acceptable by Perkins to reclaim the coolant.

For information regarding the disposal and the recycling of used coolant, consult your Perkins dealer or your Perkins distributor.

Flush

1. Flush the cooling system with clean water in order to remove any debris.
2. Close the drain cock or install the drain plug in the engine. Close the drain cock or install the drain plug on the radiator.

NOTICE

Do not fill the cooling system faster than 5 L (1.3 US gal) per minute to avoid air locks.

Cooling system air locks may result in engine damage.

3. Fill the cooling system with clean water. Install the cooling system filler cap.

i02675588

4. Start and run the engine at low idle until the temperature reaches 49 to 66 °C (120 to 150 °F).
5. Stop the engine and allow the engine to cool. Loosen the cooling system filler cap slowly in order to relieve any pressure. Remove the cooling system filler cap. Open the drain cock or remove the drain plug on the engine. Open the drain cock or remove the drain plug on the radiator. Allow the water to drain. Flush the cooling system with clean water.

Fill

1. Close the drain cock or install the drain plug on the engine. Close the drain cock or install the drain plug on the radiator.

NOTICE

Do not fill the cooling system faster than 5 L (1.3 US gal) per minute to avoid air locks.

Cooling system air locks may result in engine damage.

2. Fill the cooling system with Extended Life Coolant (ELC). Refer to the Operation and Maintenance Manual, "Fluid Recommendations" topic (Maintenance Section) for more information on cooling system specifications. Do not install the cooling system filler cap.
3. Start and run the engine at low idle. Increase the engine rpm to high idle. Run the engine at high idle for one minute in order to purge the air from the cavities of the engine block. Stop the engine.
4. Check the coolant level. Maintain the coolant level within 13 mm (0.5 inch) below the bottom of the pipe for filling. Maintain the coolant level in the expansion bottle (if equipped) at the correct level.
5. Clean the cooling system filler cap. Inspect the gasket that is on the cooling system filler cap. If the gasket that is on the cooling system filler cap is damaged, discard the old cooling system filler cap and install a new cooling system filler cap. If the gasket that is on the cooling system filler cap is not damaged, use a suitable pressurizing pump in order to pressure test the cooling system filler cap. The correct pressure for the cooling system filler cap is stamped on the face of the cooling system filler cap. If the cooling system filler cap does not retain the correct pressure, install a new cooling system filler cap.
6. Start the engine. Inspect the cooling system for leaks and for correct operating temperature.

Cooling System Coolant Level - Check

Engines With a Coolant Recovery Tank

Note: The cooling system may not have been provided by Perkins. The procedure that follows is for typical cooling systems. Refer to the OEM information for the correct procedures.

Check the coolant level when the engine is stopped and cool.

1. Observe the coolant level in the coolant recovery tank. Maintain the coolant level to "COLD FULL" mark on the coolant recovery tank.

WARNING

Pressurized System: Hot coolant can cause serious burns. To open the cooling system filler cap, stop the engine and wait until the cooling system components are cool. Loosen the cooling system pressure cap slowly in order to relieve the pressure.

2. Loosen filler cap slowly in order to relieve any pressure. Remove the filler cap.
3. Pour the correct coolant mixture into the tank. Refer to the Operation and Maintenance Manual, "Refill Capacities and Recommendations" for information on the correct mixture and type of coolant. Refer to the Operation and Maintenance Manual, "Refill Capacities and Recommendations" for the cooling system capacity. Do not fill the coolant recovery tank above "COLD FULL" mark.

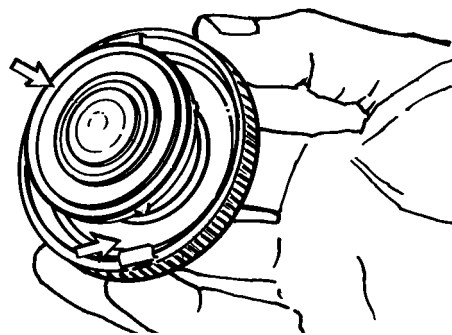

- Clean filler cap and the receptacle. Reinstall the filler cap and inspect the cooling system for leaks.

Note: The coolant will expand as the coolant heats up during normal engine operation. The additional volume will be forced into the coolant recovery tank during engine operation. When the engine is stopped and cool, the coolant will return to the engine.

Engines Without a Coolant Recovery Tank

Check the coolant level when the engine is stopped and cool.

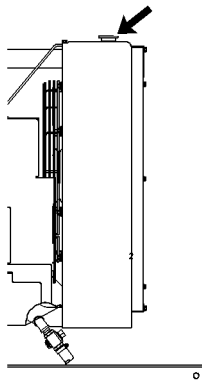

Illustration 23

g00285520

Cooling system filler cap

! WARNING

Pressurized System: Hot coolant can cause serious burns. To open the cooling system filler cap, stop the engine and wait until the cooling system components are cool. Loosen the cooling system pressure cap slowly in order to relieve the pressure.

- Remove the cooling system filler cap slowly in order to relieve pressure.
- Maintain the coolant level within 13 mm (0.5 inch) of the bottom of the filler pipe. If the engine is equipped with a sight glass, maintain the coolant level to the correct level in the sight glass.
- Clean the cooling system filler cap and inspect the gasket. If the gasket is damaged, discard the old filler cap and install a new filler cap. If the gasket is not damaged, use a suitable pressurizing pump in order to pressure test the filler cap. The correct pressure is stamped on the face of the filler cap. If the filler cap does not retain the correct pressure, install a new filler cap.
- Inspect the cooling system for leaks.

i02675604

Cooling System Supplemental Coolant Additive (SCA) - Test/Add

! WARNING

Cooling system coolant additive contains alkali. To help prevent personal injury, avoid contact with the skin and the eyes. Do not drink cooling system coolant additive.

Test for SCA Concentration

Heavy-Duty Coolant/Antifreeze and SCA

NOTICE

Do not exceed the recommended six percent supplemental coolant additive concentration.

Use a Coolant Conditioner Test Kit in order to check the concentration of the SCA.

Add the SCA, If Necessary

NOTICE

Do not exceed the recommended amount of supplemental coolant additive concentration. Excessive supplemental coolant additive concentration can form deposits on the higher temperature surfaces of the cooling system, reducing the engine's heat transfer characteristics. Reduced heat transfer could cause cracking of the cylinder head and other high temperature components. Excessive supplemental coolant additive concentration could also result in radiator tube blockage, overheating, and/or accelerated water pump seal wear. Never use both liquid supplemental coolant additive and the spin-on element (if equipped) at the same time. The use of those additives together could result in supplemental coolant additive concentration exceeding the recommended maximum.

! WARNING

Pressurized System: Hot coolant can cause serious burns. To open the cooling system filler cap, stop the engine and wait until the cooling system components are cool. Loosen the cooling system pressure cap slowly in order to relieve the pressure.

1. Slowly loosen the cooling system filler cap in order to relieve the pressure. Remove the cooling system filler cap.

Note: Always discard drained fluids according to local regulations.

2. If necessary, drain some coolant from the cooling system into a suitable container in order to allow space for the extra SCA.
3. Add the correct amount of SCA. Refer to the Operation and Maintenance Manual, "Refill Capacities and Recommendations" for more information on SCA requirements.
4. Clean the cooling system filler cap and inspect the gasket. If the gasket is damaged, discard the old filler cap and install a new filler cap. If the gasket is not damaged, use a suitable pressurizing pump in order to pressure test the filler cap. The correct pressure is stamped on the face of the filler cap. If the filler cap does not retain the correct pressure, install a new filler cap.

i02690442

Crankcase Breather (Canister) - Replace

NOTICE

Ensure that the engine is stopped before any servicing or repair is performed.

Note: The breather assembly is not installed on all engines.

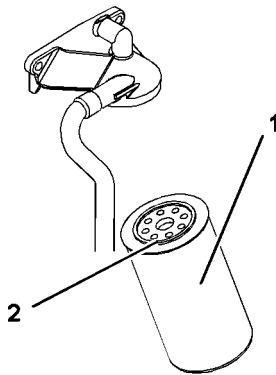

Illustration 24

g01350307

Typical example

1. Place a container under the canister (1).
2. Clean the outside of the canister. Use a suitable tool in order to remove the canister.

3. Lubricate the O ring seal (2) on the new canister with clean engine lubricating oil. Install the new canister. Tighten the canister to 12 N·m (8 lb ft). Do not overtighten the canister.

4. Remove the container. Dispose of the old canister and any split oil in a safe place.

i02676008

Driven Equipment - Check

Refer to the OEM specifications for more information on the following maintenance recommendations for the driven equipment:

- Inspection
- Adjustment
- Lubrication
- Other maintenance recommendations

Perform any maintenance for the driven equipment which is recommended by the OEM.

i02683047

Engine - Clean

WARNING

Personal injury or death can result from high voltage.

Moisture can create paths of electrical conductivity.

Make sure that the electrical system is OFF. Lock out the starting controls and tag the controls "DO NOT OPERATE".

NOTICE

Accumulated grease and oil on an engine is a fire hazard. Keep the engine clean. Remove debris and fluid spills whenever a significant quantity accumulates on the engine.

NOTICE

Failure to protect some engine components from washing may make your engine warranty invalid. Allow the engine to cool for one hour before washing the engine.

Periodic cleaning of the engine is recommended. Steam cleaning the engine will remove accumulated oil and grease. A clean engine provides the following benefits:

- Easy detection of fluid leaks
- Maximum heat transfer characteristics
- Ease of maintenance

Note: Caution must be used in order to prevent electrical components from being damaged by excessive water when the engine is cleaned. When a pressure washer or steam cleaner is used to clean the engine, a minimum distance of 300 mm (12 inch) must be maintained between the components of the engine and the jet nozzle of the pressure washer or steam cleaner. Pressure washers and steam cleaners should not be directed at any electrical connectors or the junction of cables into the rear of the connectors. Avoid electrical components such as the alternator and the starter. Protect the fuel injection pump from fluids in order to wash the engine.

i02690459

Engine Air Cleaner Element (Dual Element) - Clean/Replace

NOTICE

Never run the engine without an air cleaner element installed. Never run the engine with a damaged air cleaner element. Do not use air cleaner elements with damaged pleats, gaskets or seals. Dirt entering the engine causes premature wear and damage to engine components. Air cleaner elements help to prevent air-borne debris from entering the air inlet.

NOTICE

Never service the air cleaner element with the engine running since this will allow dirt to enter the engine.

Servicing the Air Cleaner Elements

Note: The air filter system may not have been provided by Perkins. The procedure that follows is for a typical air filter system. Refer to the OEM information for the correct procedure.

If the air cleaner element becomes plugged, the air can split the material of the air cleaner element. Unfiltered air will drastically accelerate internal engine wear. Refer to the OEM information for the correct air cleaner elements for your application.

- Check the precleaner (if equipped) and the dust bowl daily for accumulation of dirt and debris. Remove any dirt and debris, as needed.
- Operating in dirty conditions may require more frequent service of the air cleaner element.
- The air cleaner element should be replaced at least one time per year. This replacement should be performed regardless of the number of cleanings.

Replace the dirty air cleaner elements with clean air cleaner elements. Before installation, the air cleaner elements should be thoroughly checked for tears and/or holes in the filter material. Inspect the gasket or the seal of the air cleaner element for damage. Maintain a supply of suitable air cleaner elements for replacement purposes.

Dual Element Air Cleaners

The dual element air cleaner contains a primary air cleaner element and a secondary air cleaner element.

The primary air cleaner element can be used up to six times if the element is properly cleaned and properly inspected. The primary air cleaner element should be replaced at least one time per year. This replacement should be performed regardless of the number of cleanings.

The secondary air cleaner element is not serviceable. Refer to the OEM information for instructions in order to replace the secondary air cleaner element.

When the engine is operating in environments that are dusty or dirty, air cleaner elements may require more frequent replacement.

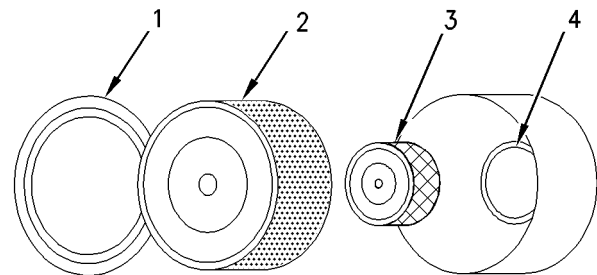

Illustration 25

g00736431

- (1) Cover
- (2) Primary air cleaner element
- (3) Secondary air cleaner element
- (4) Air inlet

1. Remove the cover. Remove the primary air cleaner element.

- The secondary air cleaner element should be removed and discarded for every three cleanings of the primary air cleaner element.

Note: Refer to “Cleaning the Primary Air Cleaner Elements”.

- Cover the air inlet with tape in order to keep dirt out.
- Clean the inside of the air cleaner cover and body with a clean, dry cloth.
- Remove the tape from the air inlet. Install the secondary air cleaner element. Install a primary air cleaner element that is new or cleaned.
- Install the air cleaner cover.
- Reset the air cleaner service indicator.

Cleaning the Primary Air Cleaner Elements

Refer to the OEM information in order to determine the number of times that the primary filter element can be cleaned. When the primary air cleaner element is cleaned, check for rips or tears in the filter material. The primary air cleaner element should be replaced at least one time per year. This replacement should be performed regardless of the number of cleanings.

NOTICE

Do not tap or strike the air cleaner element.

Do not wash the primary air cleaner element.

Use low pressure (207 kPa; 30 psi maximum) pressurized air or vacuum cleaning to clean the primary air cleaner element.

Take extreme care in order to avoid damage to the air cleaner elements.

Do not use air cleaner elements that have damaged pleats, gaskets or seals.

Refer to the OEM information in order to determine the number of times that the primary air cleaner element can be cleaned. Do not clean the primary air filter element more than three times. The primary air cleaner element must be replaced at least one time per year.

Cleaning the air filter element will not extend the life of the air filter element.

Visually inspect the primary air cleaner element before cleaning. Inspect air cleaner elements for damage to the pleats, the seals, the gaskets and the outer cover. Discard any damaged air cleaner element.

Two methods may be used in order to clean the primary air cleaner element:

- pressurized air
- Vacuum cleaning

Pressurized Air

WARNING

Personal injury can result from air pressure.

Personal injury can result without following proper procedure. When using pressure air, wear a protective face shield and protective clothing.

Maximum air pressure at the nozzle must be less than 205 kPa (30 psi) for cleaning purposes.

Pressurized air can be used to clean primary air cleaner elements that have not been cleaned more than three times. Use filtered, dry air with a maximum pressure of 207 kPa (30 psi). Pressurized air will not remove deposits of carbon and oil.

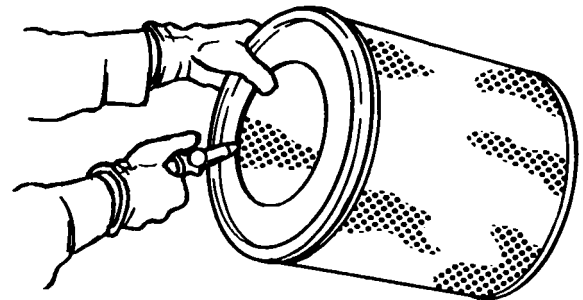

Illustration 26

g00281692

Note: When the primary air cleaner elements are cleaned, always begin with the clean side (inside) in order to force dirt particles toward the dirty side (outside).

Aim the air hose so that air flows along the length of the filter. Follow the direction of the paper pleats in order to prevent damage to the pleats. Do not aim the air directly at the face of the paper pleats.

Note: Refer to “Inspecting the Primary Air Cleaner Elements”.

Vacuum Cleaning

i02676010

Vacuum cleaning is a good method for removing accumulated dirt from the dirty side (outside) of a primary air cleaner element. Vacuum cleaning is especially useful for cleaning primary air cleaner elements which require daily cleaning because of a dry, dusty environment.

Cleaning from the clean side (inside) with pressurized air is recommended prior to vacuum cleaning the dirty side (outside) of a primary air cleaner element.

Note: Refer to "Inspecting the Primary Air Cleaner Elements".

Inspecting the Primary Air Cleaner Elements

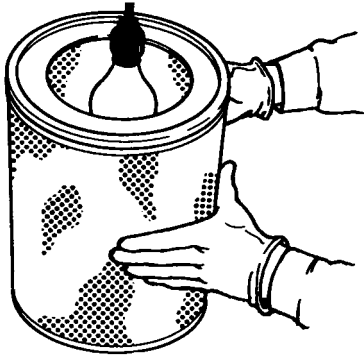

Illustration 27

g00281693

Inspect the clean, dry primary air cleaner element. Use a 60 watt blue light in a dark room or in a similar facility. Place the blue light in the primary air cleaner element. Rotate the primary air cleaner element. Inspect the primary air cleaner element for tears and/or holes. Inspect the primary air cleaner element for light that may show through the filter material. If it is necessary in order to confirm the result, compare the primary air cleaner element to a new primary air cleaner element that has the same part number.

Do not use a primary air cleaner element that has any tears and/or holes in the filter material. Do not use a primary air cleaner element with damaged pleats, gaskets or seals. Discard damaged primary air cleaner elements.

Engine Air Cleaner Element (Single Element) - Inspect/Replace

Refer to Operation and Maintenance Manual, "Engine Air Cleaner Service Indicator-Inspect".

NOTICE

Never run the engine without an air cleaner element installed. Never run the engine with a damaged air cleaner element. Do not use air cleaner elements with damaged pleats, gaskets or seals. Dirt entering the engine causes premature wear and damage to engine components. Air cleaner elements help to prevent air-borne debris from entering the air inlet.

NOTICE

Never service the air cleaner element with the engine running since this will allow dirt to enter the engine.

A wide variety of air cleaners may be installed for use with this engine. Consult the OEM information for the correct procedure to replace the air cleaner.

i02676011

Engine Air Cleaner Service Indicator - Inspect

Some engines may be equipped with a different service indicator.

Some engines are equipped with a differential gauge for inlet air pressure. The differential gauge for inlet air pressure displays the difference in the pressure that is measured before the air cleaner element and the pressure that is measured after the air cleaner element. As the air cleaner element becomes dirty, the pressure differential rises. If your engine is equipped with a different type of service indicator, follow the OEM recommendations in order to service the air cleaner service indicator.

The service indicator may be mounted on the air cleaner element or in a remote location.

i02690451

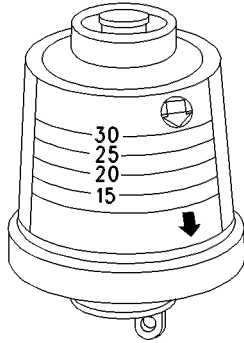

Illustration 28

g00103777

Typical service indicator

Observe the service indicator. The air cleaner element should be cleaned or the air cleaner element should be replaced when one of the following conditions occur:

- The yellow diaphragm enters the red zone.
- The red piston locks in the visible position.

Test the Service Indicator

Service indicators are important instruments.

- Check for ease of resetting. The service indicator should reset in less than three pushes.
- Check the movement of the yellow core when the engine is accelerated to the engine rated speed. The yellow core should latch approximately at the greatest vacuum that is attained.

If the service indicator does not reset easily, or if the yellow core does not latch at the greatest vacuum, the service indicator should be replaced. If the new service indicator will not reset, the hole for the service indicator may be restricted.

The service indicator may need to be replaced frequently in environments that are severely dusty.

Engine Air Precleaner - Check/Clean

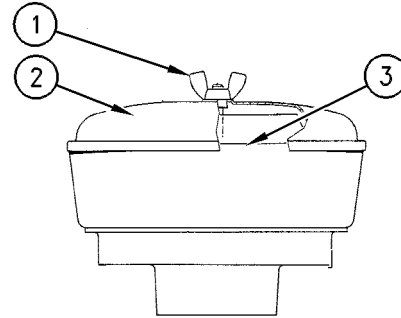

Illustration 29

g00287039

Typical example

- (1) Wing nut
- (2) Cover
- (3) Body

Remove wing nut (1) and cover (2). Check for an accumulation of dirt and debris in body (3). Clean the body, if necessary.

After cleaning the pre-cleaner, install cover (2) and wing nut (1).

Note: When the engine is operated in dusty applications, more frequent cleaning is required.

i02676012

Engine Mounts - Inspect

Note: The engine mounts may not have been supplied by Perkins. Refer to the OEM information for further information on the engine mounts and the correct bolt torque.

Inspect the engine mounts for deterioration and for correct bolt torque. Engine vibration can be caused by the following conditions:

- Incorrect mounting of the engine
- Deterioration of the engine mounts
- Loose engine mounts

Any engine mount that shows deterioration should be replaced. Refer to the OEM information for the recommended torques.

i02676018

i04478611

Engine Oil Level - Check

WARNING

Hot oil and hot components can cause personal injury. Do not allow hot oil or hot components to contact the skin.

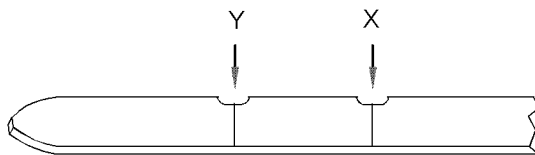

Illustration 30

g01165836

(Y) "MIN" mark. (X) "MAX" mark.

NOTICE

Perform this maintenance with the engine stopped.

Note: Ensure that the engine is either level or that the engine is in the normal operating position in order to obtain a true level indication.

Note: After the engine has been switched OFF, allow the engine oil to drain to the oil pan before checking the oil level.

1. Maintain the oil level between the "MIN" mark (Y) and the "MAX" mark (X) on the engine oil dipstick. Do not fill the crankcase above the "MAX" mark (X).

NOTICE

Operating your engine when the oil level is above the "FULL" mark could cause your crankshaft to dip into the oil. The air bubbles created from the crankshaft dipping into the oil reduces the oil's lubricating characteristics and could result in the loss of power.

2. Remove the oil filler cap and add oil, if necessary. Clean the oil filler cap. Install the oil filler cap.

Engine Oil and Filter - Change

WARNING

Hot oil and hot components can cause personal injury. Do not allow hot oil or hot components to contact the skin.

Do not drain the oil when the engine is cold. As the oil cools, suspended waste particles settle on the bottom of the oil pan. The waste particles are not removed with the draining cold oil. Drain the crankcase with the engine stopped. Drain the crankcase with the oil warm. This draining method allows the waste particles that are suspended in the oil to be drained properly.

Failure to follow this recommended procedure will cause the waste particles to be recirculated through the engine lubrication system with the new oil.

Drain the Engine Oil

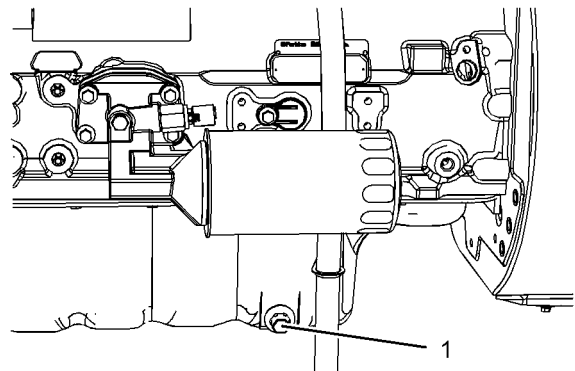

Illustration 31

g01356033

Oil drain plug

After the engine has been run at the normal operating temperature, stop the engine. Use one of the following methods to drain the engine crankcase oil:

- If the engine is equipped with a drain valve, turn the drain valve knob counterclockwise in order to drain the oil. After the oil has drained, turn the drain valve knob clockwise in order to close the drain valve.

- If the engine is not equipped with a drain valve, remove the oil drain plug (1) in order to allow the oil to drain. If the engine is equipped with a shallow sump, remove the bottom oil drain plugs from both ends of the oil pan.

After the oil has drained, the oil drain plugs should be cleaned and installed. If necessary, renew the O ring seal on the drain plug.

Some types of oil pans have oil drain plugs that are on both sides of the oil pan, because of the shape of the pan. This type of oil pan requires the engine oil to be drained from both plugs.

Replace the Spin-on Oil Filter

NOTICE

Perkins oil filters are manufactured to Perkins specifications. Use of an oil filter that is not recommended by Perkins could result in severe damage to the engine bearings, crankshaft, etc., as a result of the larger waste particles from unfiltered oil entering the engine lubricating system. Only use oil filters recommended by Perkins.

1. Remove the oil filter with a suitable tool.

Note: The following actions can be carried out as part of the preventive maintenance program.

2. Cut the oil filter open with a suitable tool. Break apart the pleats and inspect the oil filter for metal debris. An excessive amount of metal debris in the oil filter may indicate early wear or a pending failure.

Use a magnet to differentiate between the ferrous metals and the nonferrous metals that are found in the oil filter element. Ferrous metals may indicate wear on the steel and cast iron parts of the engine.

Nonferrous metals may indicate wear on the aluminum parts, brass parts, or bronze parts of the engine. Parts that may be affected include the following items: main bearings, rod bearings, turbocharger bearings, and cylinder heads.

Due to normal wear and friction, it is not uncommon to find small amounts of debris in the oil filter.

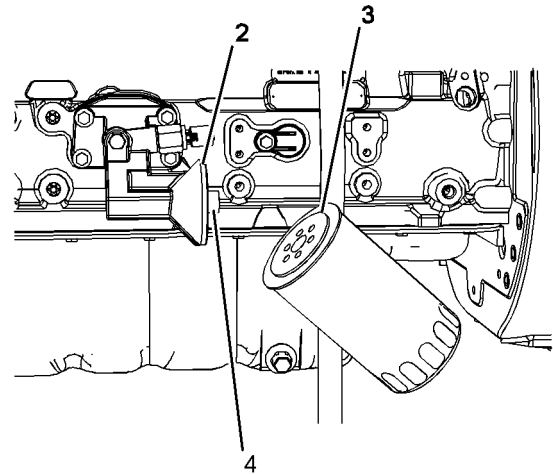

Illustration 32

g01356034

- (2) Filter head
- (3) O ring seal

3. Clean the sealing surface of the oil filter head (2). Ensure that the union (4) in the oil filter head is secure.
4. Apply clean engine oil to the O ring seal (3) on the oil filter.

NOTICE

Do not fill the oil filters with oil before installing them. This oil would not be filtered and could be contaminated. Contaminated oil can cause accelerated wear to engine components.

5. Install the oil filter. Tighten the oil filter by hand according to the instructions that are shown on the oil filter. Do not overtighten the oil filter.

Note: Some oil filters may be installed vertically. Refer to illustration 33. Start at step (1) in order to remove the oil filter and install the oil filter.

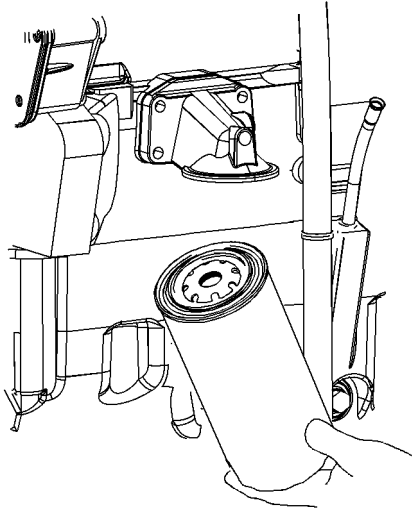

Illustration 33
Typical example

g02659217

Fill the Engine Crankcase

1. Remove the oil filler cap. Refer to the Operation and Maintenance Manual for more information on lubricant specifications. Fill the crankcase with the proper amount of oil. Refer to the Operation and Maintenance Manual for more information on refill capacities.

NOTICE

If equipped with an auxiliary oil filter system or a remote oil filter system, follow the OEM or filter manufacturer's recommendations. Under filling or overfilling the crankcase with oil can cause engine damage.

NOTICE

To prevent crankshaft bearing damage, crank the engine with the fuel OFF. This will fill the oil filters before starting the engine. Do not crank the engine for more than 30 seconds.

2. Start the engine and run the engine at "LOW IDLE" for 2 minutes. Perform this procedure in order to ensure that the lubrication system has oil and that the oil filters are filled. Inspect the oil filter for oil leaks.
3. Stop the engine and allow the oil to drain back to the sump for a minimum of 10 minutes.

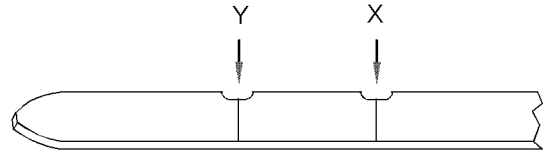

Illustration 34

g01165836

(Y) "MIN" mark. (X) "MAX" mark.

4. Remove the oil level gauge in order to check the oil level. Maintain the oil level between the "MIN" and "MAX" marks on the engine oil dipstick.

i02171102

Engine Valve Lash - Inspect/Adjust

This maintenance is recommended by Perkins as part of a lubrication and preventive maintenance schedule in order to help provide maximum engine life.

NOTICE

Only qualified service personnel should perform this maintenance. Refer to the Service Manual or your authorized Perkins dealer or your Perkins distributor for the complete valve lash adjustment procedure.

Operation of Perkins engines with incorrect valve lash can reduce engine efficiency, and also reduce engine component life.

WARNING

Ensure that the engine can not be started while this maintenance is being performed. To help prevent possible injury, do not use the starting motor to turn the flywheel.

Hot engine components can cause burns. Allow additional time for the engine to cool before measuring/adjusting valve lash clearance.

Ensure that the engine is stopped before measuring the valve lash. The engine valve lash can be inspected and adjusted when the temperature of the engine is hot or cold.

Refer to Systems Operation/Testing and Adjusting, "Engine Valve Lash - Inspect/Adjust" for more information.

i02682385

Fuel Injector - Test/Change

WARNING

Fuel leaked or spilled onto hot surfaces or electrical components can cause a fire.

NOTICE

Do not allow dirt to enter the fuel system. Thoroughly clean the area around a fuel system component that will be disconnected. Fit a suitable cover over disconnected fuel system component.

NOTICE

If a fuel injector is suspected of operating outside of normal parameters it should be removed by a qualified technician. The suspect fuel injector should be taken to an authorised agent for inspection.

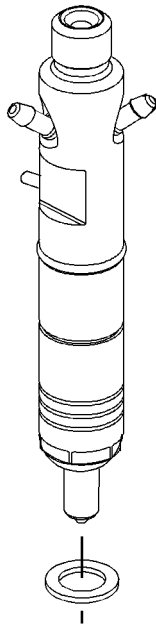

Illustration 35

Typical fuel injector

g01347499

The fuel injectors should not be cleaned as cleaning with incorrect tools can damage the nozzle. The fuel injectors should be renewed only if a fault with the fuel injectors occurs. Some of the problems that may indicate that new fuel injectors are needed are listed below:

- The engine will not start or the engine is difficult to start.
- Not enough power
- The engine misfires or the engine runs erratically.
- High fuel consumption
- Black exhaust smoke
- The engine knocks or there is vibration in the engine.
- Excessive engine temperature

Removal and Installation of the Fuel Injectors

WARNING

Work carefully around an engine that is running. Engine parts that are hot, or parts that are moving, can cause personal injury.

WARNING

Make sure that you wear eye protection at all times during testing. When fuel injection nozzles are tested, test fluids travel through the orifices of the nozzle tip with high pressure. Under this amount of pressure, the test fluid can pierce the skin and cause serious injury to the operator. Always keep the tip of the fuel injection nozzle pointed away from the operator and into the fuel collector and extension.

NOTICE

If your skin comes into contact with high pressure fuel, obtain medical assistance immediately.

Operate the engine at a fast idle speed in order to identify the faulty fuel injector. Individually loosen and tighten the union nut for the high pressure pipe to each fuel injector. Do not loosen the union nut more than half a turn. There will be little effect on the engine speed when the union nut to the faulty fuel injection nozzle is loosened. Refer to the Disassembly and Assembly Manual for more information. Consult your authorized Perkins dealer or your Perkins distributor for assistance.

i04429191

Fuel System - Prime

If air enters the fuel system, the air must be purged from the fuel system before the engine can be started. Air can enter the fuel system when the following events occur:

- The fuel tank is empty or the fuel tank has been partially drained.
- The low-pressure fuel lines are disconnected.
- A leak exists in the low-pressure fuel system.
- The fuel filter is replaced.
- A new injection pump is installed.

Use the following procedure in order to remove air from the fuel system:

1. Turn the keyswitch to the RUN position. Leave the keyswitch in the RUN position for 3 minutes. If a manual purging screw is installed, the purging screw should be slackened during priming the fuel system.

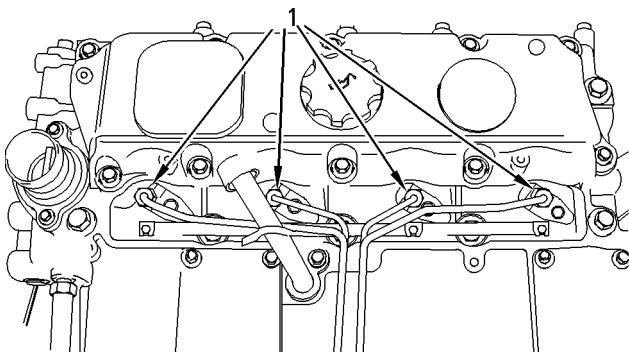

Illustration 36

g01003929

Injector nuts

2. Crank the engine with the throttle lever in the CLOSED position until the engine starts.

Note: If necessary, loosen the union nuts (1) on the fuel injection lines at the connection with the fuel injector until fuel is evident. Stop cranking the engine. Tighten the union nuts (1) to a torque of 30 N·m (22 lb ft).

3. Start the engine and run the engine at idle for 1 minute.

NOTICE

Do not crank the engine continuously for more than 30 seconds. Allow the starting motor to cool for two minutes before cranking the engine again.

4. Cycle the throttle lever from the low idle position to the high idle position three times. The cycle time for the throttle lever is one second to six seconds for one complete cycle.

Note: In order to purge air from the fuel injection pump on engines with a fixed throttle, the engine should be run at full load for 30 seconds. The load should then be decreased until the engine is at high idle. The process should be repeated three times. Repeating the process three times will assist in removing trapped air from the fuel injection pump.

5. Check for leaks in the fuel system.

i02699996

Fuel System Primary Filter (Water Separator) Element - Replace

⚠ WARNING

Fuel leaked or spilled onto hot surfaces or electrical components can cause a fire. To help prevent possible injury, turn the start switch off when changing fuel filters or water separator elements. Clean up fuel spills immediately.

NOTICE

Do not allow dirt to enter the fuel system. Thoroughly clean the area around a fuel system component that will be disconnected. Fit a suitable cover over disconnected fuel system component.

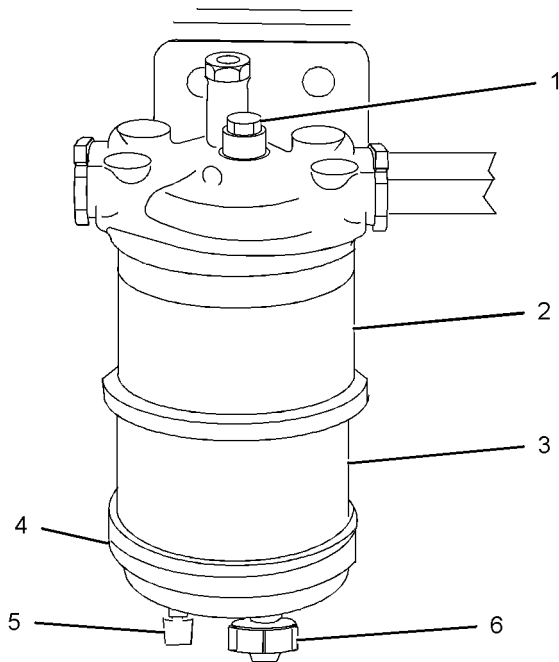

Illustration 37

g01353878

- (1) Screw
- (2) Element
- (3) Bowl
- (4) Bottom cover
- (5) Drain
- (6) Sensor connection

1. Turn the fuel supply valve (if equipped) to the OFF position.
2. Place a suitable container under the water separator. Clean the outside of the water separator.
3. Open the drain (5). Allow the fluid to drain into the container.
4. Tighten the drain (5) by hand pressure only.
5. Hold the element (2) and remove the screw (1). Remove the element and the bowl (3) from the base. Discard the old element.
6. Clean the bowl (4). Clean the bottom cover (6).
7. Install the new O ring seal. Install the bottom cover onto the new element. Install the assembly onto the base.
8. Install the screw (1) and tighten the screw to a torque of 8 N·m (6 lb ft).

9. Remove the container and dispose of the fuel safely.

10. Open the fuel supply valve.

11. Prime the fuel system. Refer to the Operation and Maintenance Manual, "Fuel System - Prime" for more information.

i02699081

Fuel System Primary Filter/Water Separator - Drain

! WARNING

Fuel leaked or spilled onto hot surfaces or electrical components can cause a fire. To help prevent possible injury, turn the start switch off when changing fuel filters or water separator elements. Clean up fuel spills immediately.

NOTICE

The water separator is not a filter. The water separator separates water from the fuel. The engine should never be allowed to run with the water separator more than half full. Engine damage may result.

NOTICE

The water separator is under suction during normal engine operation. Ensure that the drain valve is tightened securely to help prevent air from entering the fuel system.

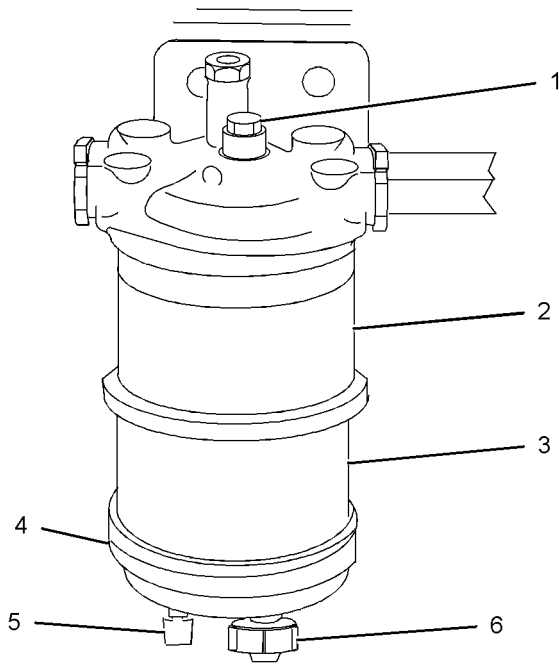

Illustration 38

g01353878

- (1) Screw
- (2) Element
- (3) Bowl
- (4) Bottom cover
- (5) Drain
- (6) Sensor connection

1. Place a suitable container below the water separator.
2. Open the drain (5). Allow the fluid to drain into the container.
3. When clean fuel drains from the water separator close the drain (5). Tighten the drain by hand pressure only. Dispose of the drained fluid correctly.

i04478612

Fuel System Secondary Filter - Replace

WARNING

Fuel leaked or spilled onto hot surfaces or electrical components can cause a fire. To help prevent possible injury, turn the start switch off when changing fuel filters or water separator elements. Clean up fuel spills immediately.

NOTICE

Do not allow dirt to enter the fuel system. Thoroughly clean the area around a fuel system component that will be disconnected. Fit a suitable cover over disconnected fuel system component.

Element filter

Turn the valves for the fuel lines (if equipped) to the OFF position before performing this maintenance. Place a tray under the fuel filter in order to catch any fuel that might spill. Clean up any spilled fuel immediately.

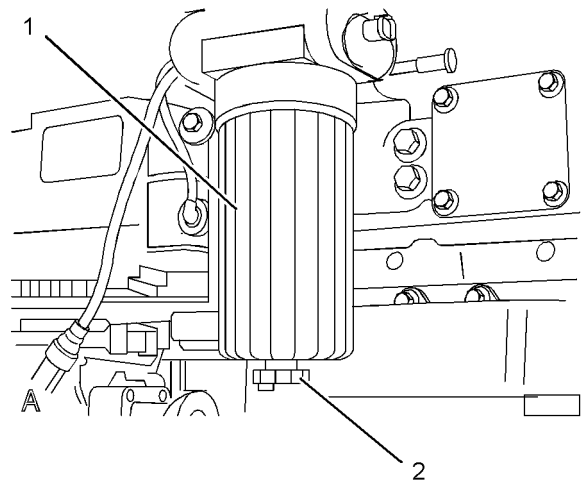

Illustration 39

g01353856

- (1) Filter bowl
- (2) Drain

1. Close the valves for the fuel lines (if equipped).
2. Clean the outside of the fuel filter assembly. Open the fuel drain (2) and drain the fuel into a suitable container.

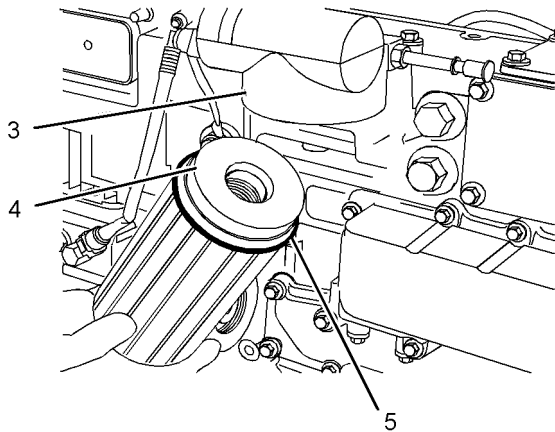

Illustration 40

g02659218

Typical example

- (3) Filter head
- (4) Element
- (5) O ring seal

3. Remove the filter bowl (1) from the filter head (3). Press on the element (4). Rotate the element counterclockwise in order to release the element from the filter bowl and remove the element from the bowl. Discard the used element.
4. Remove the O ring (5) from the filter bowl and clean the filter bowl. Check that the threads of the filter bowl are not damaged.
5. Install a new O ring seal (5) to the filter bowl (1).
6. Locate a new filter element (4) into the filter bowl (1). Press on the element and rotate the element clockwise in order to lock the element into the filter bowl.
7. Install the filter bowl (1) into the top of the filter head (3).
8. Tighten the filter bowl by hand until the filter bowl contacts the filter head. Rotate the filter bowl through 90 degrees.

Note: Do not use a tool to tighten the filter bowl.

9. Open the valves for the fuel lines (if equipped).

Spin-on filter

Turn the valves for the fuel lines (if equipped) to the OFF position before performing this maintenance. Place a tray under the fuel filter in order to catch any fuel that might spill. Clean up any spilled fuel immediately.

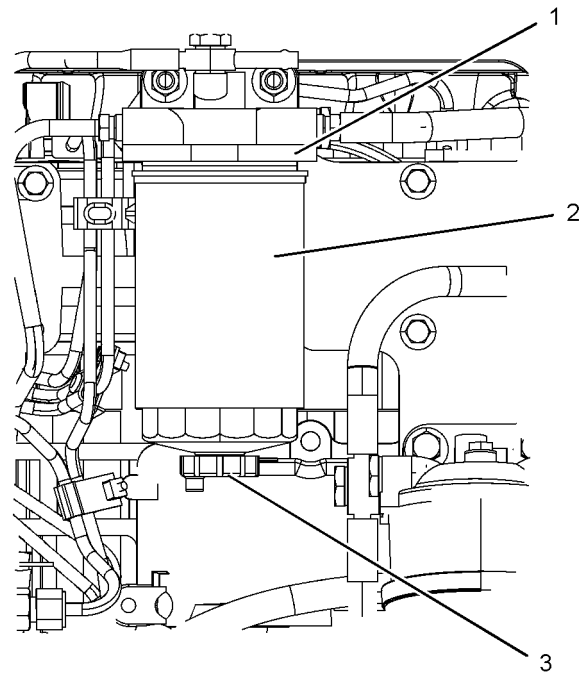

Illustration 41

g01353858

- (1) Filter Head
- (2) Spin-on filter
- (3) Drain

1. Clean the outside of the fuel filter assembly. Open the fuel drain (3) and drain the fuel into a suitable container.
2. Use a suitable tool in order to remove the spin-on filter (2) from the filter head (1).
3. Ensure that the fuel drain (3) on the new spin-on filter is closed.

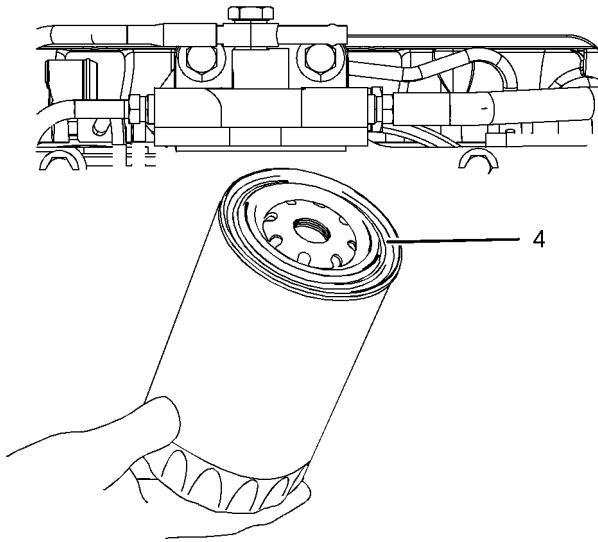

Illustration 42

g02659219

Typical example

(4) O ring seal

4. Lubricate the sealing ring (4) with clean fuel oil.
5. Install the spin-on filter (2) into the top of the filter head (1).
6. Tighten the spin-on filter by hand until the sealing ring contacts the filter head. Rotate the spin-on filter through 90 degrees.
7. Prime the fuel system. Refer to Operation and Maintenance Manual, "Fuel System - Prime".

i02677376

Fuel Tank Water and Sediment - Drain

NOTICE

Care must be taken to ensure that fluids are contained during performance of inspection, maintenance, testing, adjusting, and repair of the product. Be prepared to collect the fluid with suitable containers before opening any compartment or disassembling any component containing fluids.

Dispose of all fluids according to local regulations and mandates.

Fuel Tank

Fuel quality is critical to the performance and to the service life of the engine. Water in the fuel can cause excessive wear to the fuel system.

Water can be introduced into the fuel tank when the fuel tank is being filled.

Condensation occurs during the heating and cooling of fuel. The condensation occurs as the fuel passes through the fuel system and the fuel returns to the fuel tank. This causes water to accumulate in fuel tanks. Draining the fuel tank regularly and obtaining fuel from reliable sources can help to eliminate water in the fuel.

Drain the Water and the Sediment

Fuel tanks should contain some provision for draining water and draining sediment from the bottom of the fuel tanks.

Open the drain valve on the bottom of the fuel tank in order to drain the water and the sediment. Close the drain valve.

Check the fuel daily. Allow five minutes after the fuel tank has been filled before draining water and sediment from the fuel tank.

Fill the fuel tank after operating the engine in order to drive out moist air. This will help prevent condensation. Do not fill the tank to the top. The fuel expands as the fuel gets warm. The tank may overflow.

Some fuel tanks use supply pipes that allow water and sediment to settle below the end of the fuel supply pipe. Some fuel tanks use supply lines that take fuel directly from the bottom of the tank. If the engine is equipped with this system, regular maintenance of the fuel system filter is important.

Fuel Storage Tanks

Drain the water and the sediment from the fuel storage tank at the following intervals:

- Weekly
- Service intervals
- Refill of the tank

This will help prevent water or sediment from being pumped from the storage tank into the engine fuel tank.

If a bulk storage tank has been refilled or moved recently, allow adequate time for the sediment to settle before filling the engine fuel tank. Internal baffles in the bulk storage tank will also help trap sediment. Filtering fuel that is pumped from the storage tank helps to ensure the quality of the fuel. When possible, water separators should be used.

i02677365

Hoses and Clamps - Inspect/Replace

Inspect all hoses for leaks that are caused by the following conditions:

- Cracking
- Softness
- Loose clamps

Replace hoses that are cracked or soft. Tighten any loose clamps.

NOTICE

Do not bend or strike high pressure lines. Do not install bent or damaged lines, tubes or hoses. Repair any loose or damaged fuel and oil lines, tubes and hoses. Leaks can cause fires. Inspect all lines, tubes and hoses carefully. Tighten all connections to the recommended torque.

Check for the following conditions:

- End fittings that are damaged or leaking
- Outer covering that is chafed or cut
- Exposed wire that is used for reinforcement
- Outer covering that is ballooning locally
- Flexible part of the hose that is kinked or crushed
- Armoring that is embedded in the outer covering

A constant torque hose clamp can be used in place of any standard hose clamp. Ensure that the constant torque hose clamp is the same size as the standard clamp.

Due to extreme temperature changes, the hose will harden. Hardening of the hoses will cause hose clamps to loosen. This can result in leaks. A constant torque hose clamp will help to prevent loose hose clamps.

Each installation application can be different. The differences depend on the following factors:

- Type of hose
- Type of fitting material
- Anticipated expansion and contraction of the hose
- Anticipated expansion and contraction of the fittings

Replace the Hoses and the Clamps

Refer to the OEM information for further information on removing and replacing fuel hoses (if equipped).

The coolant system and the hoses for the coolant system are not usually supplied by Perkins. The following text describes a typical method of replacing coolant hoses. Refer to the OEM information for further information on the coolant system and the hoses for the coolant system.

WARNING

Pressurized System: Hot coolant can cause serious burns. To open the cooling system filler cap, stop the engine and wait until the cooling system components are cool. Loosen the cooling system pressure cap slowly in order to relieve the pressure.

1. Stop the engine. Allow the engine to cool.
2. Loosen the cooling system filler cap slowly in order to relieve any pressure. Remove the cooling system filler cap.
3. Drain the coolant from the cooling system to a level that is below the hose that is being replaced.
4. Remove the hose clamps.
5. Disconnect the old hose.
6. Replace the old hose with a new hose.
7. Install the hose clamps with a torque wrench.

Note: For the correct coolant, see this Operation and Maintenance Manual, "Fluid Recommendations".

8. Refill the cooling system. Refer to the OEM information for further information on refilling the cooling system.

9. Clean the cooling system filler cap. Inspect the cooling system filler cap's seals. Replace the cooling system filler cap if the seals are damaged. Install the cooling system filler cap.
10. Start the engine. Inspect the cooling system for leaks.

i02335774

Radiator - Clean

The radiator is not usually supplied by Perkins. The following text describes a typical cleaning procedure for the radiator. Refer to the OEM information for further information on cleaning the radiator.

Note: Adjust the frequency of cleaning according to the effects of the operating environment.

Inspect the radiator for these items: Damaged fins, corrosion, dirt, grease, insects, leaves, oil, and other debris. Clean the radiator, if necessary.

WARNING

Personal injury can result from air pressure.

Personal injury can result without following proper procedure. When using pressure air, wear a protective face shield and protective clothing.

Maximum air pressure at the nozzle must be less than 205 kPa (30 psi) for cleaning purposes.

Pressurized air is the preferred method for removing loose debris. Direct the air in the opposite direction to the fan's air flow. Hold the nozzle approximately 6 mm (0.25 inch) away from the radiator fins. Slowly move the air nozzle in a direction that is parallel with the radiator tube assembly. This will remove debris that is between the tubes.

Pressurized water may also be used for cleaning. The maximum water pressure for cleaning purposes must be less than 275 kPa (40 psi). Use pressurized water in order to soften mud. Clean the core from both sides.

Use a degreaser and steam for removal of oil and grease. Clean both sides of the core. Wash the core with detergent and hot water. Thoroughly rinse the core with clean water.

If the radiator is blocked internally, refer to the OEM Manual for information regarding flushing the cooling system.

After cleaning the radiator, start the engine. Allow the engine to operate at low idle speed for three to five minutes. Accelerate the engine to high idle. This will help in the removal of debris and the drying of the core. Slowly reduce the engine speed to low idle and then stop the engine. Use a light bulb behind the core in order to inspect the core for cleanliness. Repeat the cleaning, if necessary.

Inspect the fins for damage. Bent fins may be opened with a "comb". Inspect these items for good condition: Welds, mounting brackets, air lines, connections, clamps, and seals. Make repairs, if necessary.

i02678846

Severe Service Application - Check

Severe service is the application of an engine that exceeds the current published standards for that engine. Perkins maintains standards for the following engine parameters:

- Performance such as power range, speed range, and fuel consumption
- Fuel quality
- Operational Altitude
- Maintenance intervals
- Oil selection and maintenance
- Coolant type and maintenance
- Environmental qualities
- Installation
- The temperature of the fluid in the engine

Refer to the standards for the engine or consult your Perkins dealer or your Perkins distributor in order to determine if the engine is operating within the defined parameters.

Severe service operation can accelerate component wear. Engines that operate under severe conditions may need more frequent maintenance intervals in order to ensure maximum reliability and retention of full service life.

Due to individual applications, it is not possible to identify all of the factors which can contribute to severe service operation. Consult your Perkins dealer or your Perkins distributor for the unique maintenance that is necessary for the engine.

The operating environment, incorrect operating procedures and incorrect maintenance procedures can be factors which contribute to a severe service application.

Environmental Factors

Ambient temperatures – The engine may be exposed to extended operation in extremely cold environments or hot environments. Valve components can be damaged by carbon buildup if the engine is frequently started and stopped in very cold temperatures. Extremely hot intake air reduces engine performance.

Quality of the air – The engine may be exposed to extended operation in an environment that is dirty or dusty, unless the equipment is cleaned regularly. Mud, dirt and dust can encase components. Maintenance can be very difficult. The buildup can contain corrosive chemicals.

Buildup – Compounds, elements, corrosive chemicals and salt can damage some components.

Altitude – Problems can arise when the engine is operated at altitudes that are higher than the intended settings for that application. Necessary adjustments should be made.

Incorrect Operating Procedures

- Extended operation at low idle
- Frequent hot shutdowns
- Operating at excessive loads
- Operating at excessive speeds
- Operating outside the intended application

Incorrect Maintenance Procedures

- Extending the maintenance intervals
- Failure to use recommended fuel, lubricants and coolant/antifreeze

i02678843

Starting Motor - Inspect

Perkins recommends a scheduled inspection of the starting motor. If the starting motor fails, the engine may not start in an emergency situation.

Check the starting motor for correct operation. Check the electrical connections and clean the electrical connections. Refer to the Systems Operation, Testing and Adjusting Manual, "Electric Starting System - Test" for more information on the checking procedure and for specifications or consult your Perkins dealer or your Perkins distributor for assistance.

i02677378

Turbocharger - Inspect (If Equipped)

A regular visual inspection of the turbocharger is recommended. Any fumes from the crankcase are filtered through the air inlet system. Therefore, by-products from oil and from combustion can collect in the turbocharger compressor housing. Over time, this buildup can contribute to loss of engine power, increased black smoke and overall loss of engine efficiency.

If the turbocharger fails during engine operation, damage to the turbocharger compressor wheel and/or to the engine may occur. Damage to the turbocharger compressor wheel can cause additional damage to the pistons, the valves, and the cylinder head.

NOTICE

Turbocharger bearing failures can cause large quantities of oil to enter the air intake and exhaust systems. Loss of engine lubricant can result in serious engine damage.

Minor leakage of oil into a turbocharger under extended low idle operation should not cause problems as long as a turbocharger bearing failure has not occurred.

When a turbocharger bearing failure is accompanied by a significant engine performance loss (exhaust smoke or engine rpm up at no load), do not continue engine operation until the turbocharger is renewed.

A visual inspection of the turbocharger can minimize unscheduled downtime. A visual inspection of the turbocharger can also reduce the chance for potential damage to other engine parts.

Removal and Installation

Note: The turbochargers that are supplied are non-serviceable.

For options regarding the removal, installation, and replacement, consult your Perkins dealer or your Perkins distributor. Refer to the Disassembly and Assembly Manual, "Turbocharger - Remove and Turbocharger - Install" for further information.

i02690446

V-Belts - Inspect/Adjust/Replace

Inspecting

NOTICE

The compressor housing for the turbocharger must not be removed from the turbocharger for cleaning.

The actuator linkage is connected to the compressor housing. If the actuator linkage is moved or disturbed the engine may not comply with emissions legislation.

1. Remove the pipe from the turbocharger exhaust outlet and remove the air intake pipe to the turbocharger. Visually inspect the piping for the presence of oil. Clean the interior of the pipes in order to prevent dirt from entering during reassembly.
2. Check for the presence of oil. If oil is leaking from the back side of the compressor wheel, there is a possibility of a failed turbocharger oil seal.

The presence of oil may be the result of extended engine operation at low idle. The presence of oil may also be the result of a restriction of the line for the intake air (clogged air filters), which causes the turbocharger to slobber.

3. Inspect the bore of the housing of the turbine outlet for corrosion.
4. Fasten the air intake pipe and the exhaust outlet pipe to the turbocharger housing.

Inspection

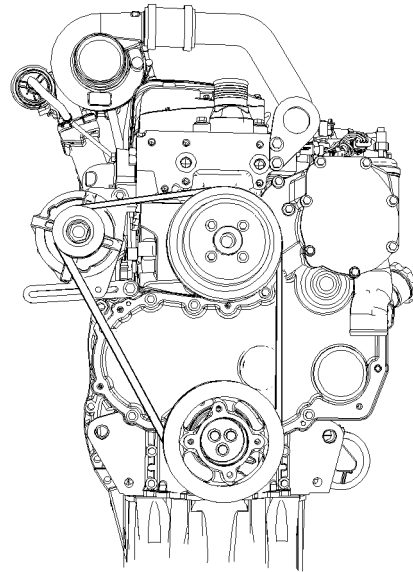

Illustration 43

g01249073

Arrangement for the V-belts

To maximize the engine performance, inspect the belts for wear and for cracking. Replace belts that are worn or damaged.

For applications that require multiple drive belts, replace the belts in matched sets. Replacing only one belt of a matched set will cause the new belt to carry more load because the older belt is stretched. The additional load on the new belt could cause the new belt to break.

If the belts are too loose, vibration causes unnecessary wear on the belts and pulleys. Loose belts may slip enough to cause overheating.

To accurately check the belt tension, a suitable gauge should be used.

i02678854

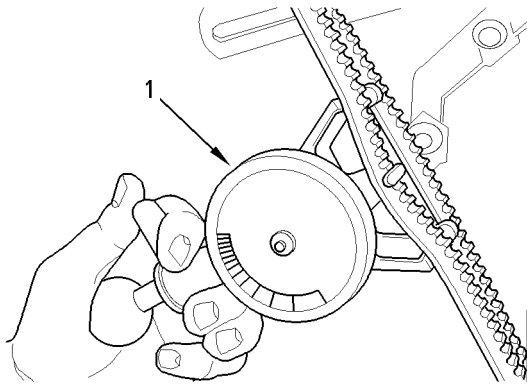

Illustration 44

g01003936

Typical example

(1) Belt tension gauge

Fit the gauge (1) at the center of the longest free length and check the tension. The correct tension for a new belt is 535 N (120 lb). If the tension of the belt is below 250 N (56 lb) adjust the belt to 535 N (120 lb).

If twin belts are installed, check the tension on both belts and adjust the tension on the tightest belt.

Adjustment

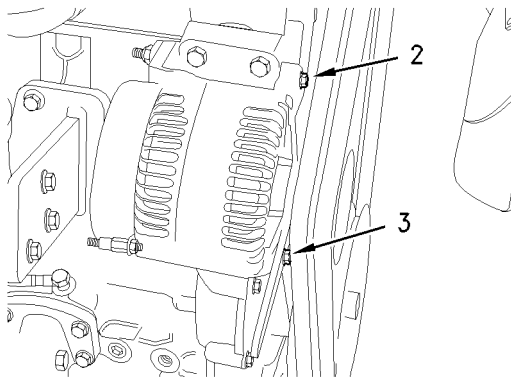

Illustration 45

g01003939

1. Loosen The alternator pivot bolt (2) and the bolt (3).
2. Move the alternator in order to increase or decrease the belt tension. Tighten the alternator pivot bolt and the link bolt to 22 N·m (16 lb ft).(1).

Replace

Refer to Disassembly and Assembly manual for more information.

Walk-Around Inspection

Inspect the Engine for Leaks and for Loose Connections

A walk-around inspection should only take a few minutes. When the time is taken to perform these checks, costly repairs and accidents can be avoided.

For maximum engine service life, make a thorough inspection of the engine compartment before starting the engine. Look for items such as oil leaks or coolant leaks, loose bolts, worn belts, loose connections and trash buildup. Make repairs, as needed:

- The guards must be in the correct place. Repair damaged guards or replace missing guards.
- Wipe all caps and plugs before the engine is serviced in order to reduce the chance of system contamination.

NOTICE

For any type of leak (coolant, lube, or fuel) clean up the fluid. If leaking is observed, find the source and correct the leak. If leaking is suspected, check the fluid levels more often than recommended until the leak is found or fixed, or until the suspicion of a leak is proved to be unwarranted.

NOTICE

Accumulated grease and/or oil on an engine is a fire hazard. Remove the accumulated grease and oil. Refer to this Operation and Maintenance Manual, "Engine - Clean" for more information.

- Ensure that the cooling system hoses are correctly clamped and that the cooling system hoses are tight. Check for leaks. Check the condition of all pipes.
- Inspect the water pump for coolant leaks.

Note: The water pump seal is lubricated by the coolant in the cooling system. It is normal for a small amount of leakage to occur as the engine cools down and the parts contract.

Excessive coolant leakage may indicate the need to replace the water pump seal. For the removal of the water pump and the installation of water pump and/or seal, refer to the Disassembly and Assembly Manual, "Water Pump - Remove and Install" for more information or consult your Perkins dealer or your Perkins distributor.

- Inspect the lubrication system for leaks at the front crankshaft seal, the rear crankshaft seal, the oil pan, the oil filters and the rocker cover.
- Inspect the fuel system for leaks. Look for loose fuel line clamps and/or tie-wraps.
- Inspect the piping for the air intake system and the elbows for cracks and for loose clamps. Ensure that hoses and tubes are not contacting other hoses, tubes, wiring harnesses, etc.
- Inspect the alternator belts and any accessory drive belts for cracks, breaks or other damage.

Belts for multiple groove pulleys must be replaced as matched sets. If only one belt is replaced, the belt will carry more load than the belts that are not replaced. The older belts are stretched. The additional load on the new belt could cause the belt to break.

- Drain the water and the sediment from the fuel tank on a daily basis in order to ensure that only clean fuel enters the fuel system.
- Inspect the wiring and the wiring harnesses for loose connections and for worn wires or frayed wires.
- Inspect the ground strap for a good connection and for good condition.
- Disconnect any battery chargers that are not protected against the current drain of the starting motor. Check the condition and the electrolyte level of the batteries, unless the engine is equipped with a maintenance free battery.
- Check the condition of the gauges. Replace any gauges that are cracked. Replace any gauge that can not be calibrated.

Note: The water pump seal is lubricated by the coolant in the cooling system. It is normal for a small amount of leakage to occur as the engine cools down and parts contract.

Visually inspect the water pump for leaks. Renew the water pump seal or the water pump if there is an excessive leakage of coolant. Refer to the Disassembly and Assembly Manual, "Water Pump - Remove and Install" for the disassembly and assembly procedure.

i01907756

Water Pump - Inspect

A failed water pump may cause severe engine overheating problems that could result in the following conditions:

- Cracks in the cylinder head
- A piston seizure
- Other potential damage to the engine

Warranty Section

Warranty Information

i02676009

Emissions Warranty Information

This engine may be certified to comply with exhaust emission standards and gaseous emission standards that are prescribed by the law at the time of manufacture, and this engine may be covered by an Emissions Warranty. Consult your authorized Perkins dealer or your authorized Perkins distributor in order to determine if your engine is emissions certified and if your engine is subject to an Emissions Warranty.

Index

A

After Starting Engine	26
After Stopping Engine.....	28
Aftercooler Core - Clean/Test	51
Aftercooler Core - Inspect.....	51
Alternator - Inspect	52
Alternator Belt - Inspect/Adjust/Replace (Poly V-Belt).....	52
Adjustment.....	52
Inspection.....	52
Replace.....	52

B

Battery - Replace.....	52
Battery Electrolyte Level - Check	53
Battery or Battery Cable - Disconnect	53
Before Starting Engine	10, 24
Burn Prevention.....	8
Batteries.....	8
Coolant.....	8
Oils.....	8

C

Cold Weather Operation.....	29
Hints for Cold Weather Operation.....	29
Idling the Engine	30
Recommendations for Coolant Warm Up	30
Recommendations for the Coolant	29
Viscosity of the Engine Lubrication Oil.....	29
Cooling System Coolant (Commercial Heavy-Duty) - Change	54
Drain	54
Fill	55
Flush	55
Cooling System Coolant (ELC) - Change.....	55
Drain	56
Fill	57
Flush	56
Cooling System Coolant Level - Check.....	57
Engines With a Coolant Recovery Tank.....	57
Engines Without a Coolant Recovery Tank.....	58
Cooling System Supplemental Coolant Additive (SCA) - Test/Add.....	58
Add the SCA, If Necessary	58
Test for SCA Concentration	58
Crankcase Breather (Canister) - Replace	59
Crushing Prevention and Cutting Prevention	10

D

Driven Equipment - Check.....	59
-------------------------------	----

E

Electrical System.....	11
Grounding Practices	11
Emergency Stopping	28
Emissions Certification Film	19
Emissions Warranty Information.....	79
Engine - Clean.....	59
Engine Air Cleaner Element (Dual Element) - Clean/Replace	60
Cleaning the Primary Air Cleaner Elements	61
Servicing the Air Cleaner Elements	60
Engine Air Cleaner Element (Single Element) - Inspect/Replace	62
Engine Air Cleaner Service Indicator - Inspect.....	62
Test the Service Indicator.....	63
Engine Air Precleaner - Check/Clean.....	63
Engine Description	15
Engine Cooling and Lubrication.....	16
Engine Service Life	17
Engine Specifications.....	16
Engine Identification	18
Engine Mounts - Inspect.....	63
Engine Oil and Filter - Change	64
Drain the Engine Oil.....	64
Fill the Engine Crankcase.....	66
Replace the Spin-on Oil Filter.....	65
Engine Oil Level - Check.....	64
Engine Operation.....	27
Engine Starting	10, 24
Engine Stopping	11, 28
Engine Valve Lash - Inspect/Adjust.....	66

F

Features and Controls.....	23
Fire Prevention and Explosion Prevention	8
Fire Extinguisher.....	9
Lines, Tubes and Hoses	10
Fluid Recommendations.....	33
Engine Oil	34
General Lubricant Information	33
Fluid Recommendations (Coolant Information).....	37
Cooling System Specifications.....	37
ELC Cooling System Maintenance	39
Fluid Recommendations (Fuel Recommendations).....	42
Diesel Fuel Characteristics	44
Diesel Fuel Requirements.....	42
General Information	42

Foreword	4	Model View Illustrations	14
California Proposition 65 Warning	4	1104 Engine Model Views	14
Literature Information	4	Model Views	13
Maintenance	4		
Maintenance Intervals	4	O	
Operation	4	Operation Section	20
Overhaul	4		
Safety	4		
Fuel and the Effect from Cold Weather	31		
Fuel Conservation Practices	27	P	
Fuel Injector - Test/Change	67	Product Identification Information	18
Removal and Installation of the Fuel Injectors ...	67	Product Information Section	13
Fuel Related Components in Cold Weather	32	Product Lifting	20
Fuel Filters	32	Product Storage	20
Fuel Heaters	32	Condition for Storage	20
Fuel Tanks	32		
Fuel Shutoff	23		
Fuel System - Prime	68	R	
Fuel System Primary Filter (Water Separator)		Radiator - Clean	74
Element - Replace	68	Reference Numbers	18
Fuel System Primary Filter/Water Separator -		Record for Reference	18
Drain	69	Refill Capacities	33
Fuel System Secondary Filter - Replace	70	Cooling System	33
Element filter	70	Lubrication System	33
Spin-on filter	71		
Fuel Tank Water and Sediment - Drain	72	S	
Drain the Water and the Sediment	72	Safety Messages	5
Fuel Storage Tanks	72	(1) Universal Warning	5
Fuel Tank	72	(2) Ether	6
		Safety Section	5
G		Serial Number Plate	18
Gauges and Indicators	22	Severe Service Application - Check	74
General Hazard Information	6	Environmental Factors	75
Containing Fluid Spillage	7	Incorrect Maintenance Procedures	75
Fluid Penetration	7	Incorrect Operating Procedures	75
Pressure Air and Water	7	Starting Motor - Inspect	75
		Starting the Engine	25
H		Starting with Jump Start Cables	25
Hoses and Clamps - Inspect/Replace	73	Stopping the Engine	28
Replace the Hoses and the Clamps	73		
		T	
I		Table of Contents	3
Important Safety Information	2	Turbocharger - Inspect (If Equipped)	75
		Inspecting	76
L		Removal and Installation	75
Lifting and Storage	20		
		V	
M		V-Belts - Inspect/Adjust/Replace	76
Maintenance Interval Schedule	50	Adjustment	77
Maintenance Section	33	Inspection	76
		Replace	77

W

Walk-Around Inspection	77
Inspect the Engine for Leaks and for Loose Connections	77
Warranty Information	79
Warranty Section	79
Water Pump - Inspect.....	78

Product and Dealer Information

Note: For product identification plate locations, see the section "Product Identification Information" in the Operation and Maintenance Manual.

Delivery Date: _____

Product Information

Model: _____

Product Identification Number: _____

Engine Serial Number: _____

Transmission Serial Number: _____

Generator Serial Number: _____

Attachment Serial Numbers: _____

Attachment Information: _____

Customer Equipment Number: _____

Dealer Equipment Number: _____

Dealer Information

Name: _____ Branch: _____

Address: _____

Dealer Contact

Phone Number

Hours

Sales: _____

Parts: _____

Service: _____

