



C4.4 ACERT™
Industrial Power Unit
 Tier 4 Final, Stage IV Technology
 74.5-129.4 bkW/100-173.5 bhp @ 2200 rpm



Image shown may not reflect actual engine configuration

CAT® ENGINE SPECIFICATIONS

I-4, 4-Stroke-Cycle Diesel

Bore	105 mm (4.13 in)
Stroke	127 mm (5.00 in)
Displacement	4.4 L (268.5 in ³)
Aspiration	Turbocharged-Aftercooled (TA) or Series Turbocharged-Aftercooled (TTA)
Compression Ratio.....	16.5:1
Combustion System.....	Direct Injection
Rotation (from flywheel end) ...	Counterclockwise
Capacity for Liquids	
Cooling System	
> 110 kW (147.5 hp)	9.4 L (8.5 U.S. qts)
< 110 kW (147.5 hp)	9 L (8.2 U.S. qts)
Lube System (refill) sump	
dependent	5.2-13.5 L (5.5-14.27 U.S. qts)
Package Weight, Net Dry (approximate)	
TA.....	670 kg (1477 lbs)
TTA.....	700 kg (1543 lbs)

FEATURES

Emissions

Designed to meet U.S. EPA Tier 4 Final, EU Stage IV emission standards.

Reliable, Quiet, and Durable Power

World-class manufacturing capability and processes coupled with proven core engine designs assure reliability, quiet operation, and many hours of productive life.

High Performance

Series turbocharging with smart wastegate available on specific ratings for fast response, high power, and increased torque.

Fuel Efficiency

Fuel consumption optimized to match operating cycles of a wide range of equipment and applications.

Fuel & Oil

Tier 4 Final/Stage IV engines require Ultra Low Sulfur Diesel (ULSD) fuel containing a maximum of 15 ppm sulfur, and new oil formulations to support the new technology. Cat® engines are designed to accommodate B20 biofuel. Your Cat dealer can provide more information regarding fuel and oil.

Broad Application Range

Industry leading range of factory configurable ratings and options for agricultural, materials-handling, construction, mining, aircraft ground support, and other industrial applications.

Package Size

Ideal for equipment with narrow engine compartments. Multiple installation options minimize total package size.

Low-Cost Maintenance

Worldwide service delivers ease of maintenance and simplifies the servicing routine. Hydraulic tappets, multi-vee belts, "no ash service" aftertreatment, and 500-hour oil change intervals enable low-cost maintenance. Many service items have a choice of location on either side of the engine to enable choice of service access. The S•O•SSM program is available from your Cat dealer to determine oil change intervals and provide optimal performance.

Quality

Every Cat engine is manufactured to stringent standards in order to assure customer satisfaction.

World-class Product Support Offered Through Global Cat Dealer Network

- Scheduled maintenance, including S•O•SSM sample
- Customer Support Agreements (CSA)
- Cat Extended Service Coverage (ESC)
- Superior dealer service network
- Extended dealer service network through the Cat Industrial Service Distributor (ISD) program

Web Site: For additional information on all your power requirements, visit www.cat-industrial.com.



C4.4 ACERT™ Industrial Power Unit

Tier 4 Final, Stage IV Technology
74.5-129.4 bkW/100-173.5 bhp @ 2200 rpm

STANDARD ENGINE EQUIPMENT

Air Inlet

Standard air cleaners

Control System

Full electronic control system, all connectors and wiring looms waterproof and designed to withstand harsh off-highway environments, flexible and configurable software features and well supported SAE J1939 CAN bus enables highly integrated machines

Cooling System

Top tank temperature 108°C (226°F) as standard to minimize cooling pack size, 50:50 water glycol mix, detailed guidance on cooling system design and validation available to ensure machine reliability

Exhaust System

Diesel Oxidation Catalyst and Selective Catalytic Reduction system supplied installed on engine. Zero downtime due to regeneration

Flywheels and Flywheel Housing

Fitted with SAE3 configuration as standard

Fuel System

Electronic high pressure common rail, ACERT™ Technology, innovative filter design to ensure maximum protection of the engine.

Lube System

Choice of sumps for different applications

Power Take Off

SAE A or SAE B flanges on left-hand side, additional SAE A flange available on LHS, engine power can also be taken from the front of the engine on some applications, compressors are also available

General

Available with or without a balancer

DIMENSIONS

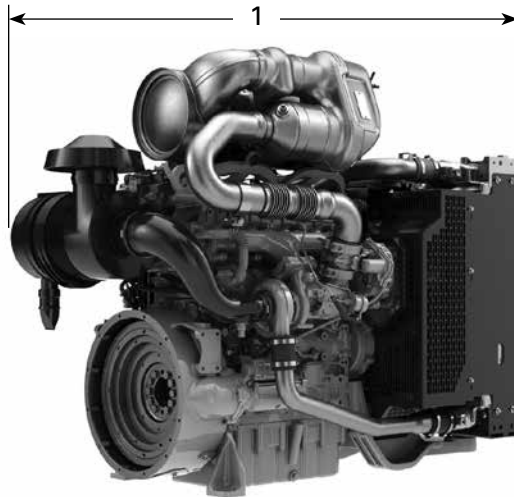

(1) Length —

TA: 1433 mm (56.4 in)
TTA: 1455 mm (57.3 in)

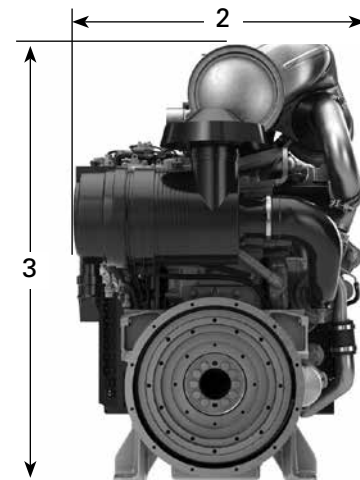

(2) Width —

TA: 819 mm (32.2 in)
TTA: 870 mm (34.3 in)

(3) Height (including aftertreatment) —

TA: 1215 mm (47.8 in)
TTA: 1280 mm (50.4 in)

Note: Final dimensions dependent on selected options



C4.4 ACERT™ Industrial Power Unit

Tier 4 Final, Stage IV Technology
74.5-129.4 bkW/100-173.5 bhp @ 2200 rpm

PERFORMANCE DATA

Rated Speed @ 2200 rpm

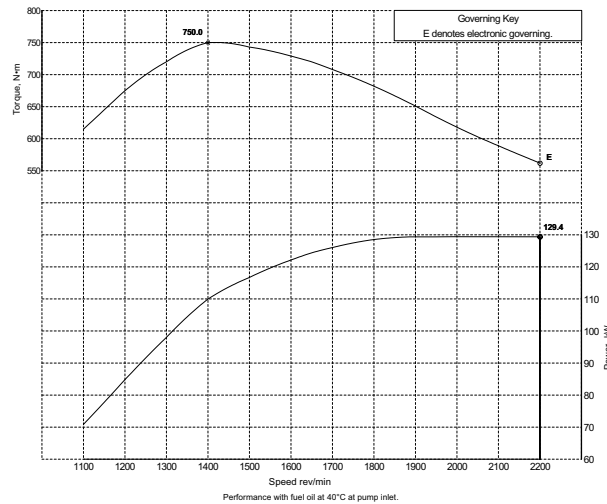
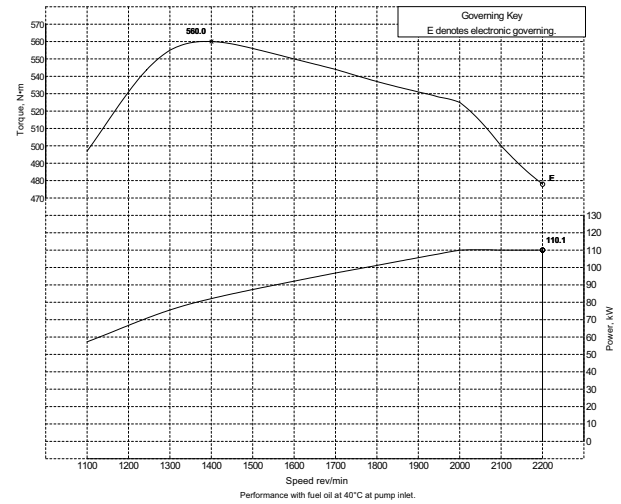
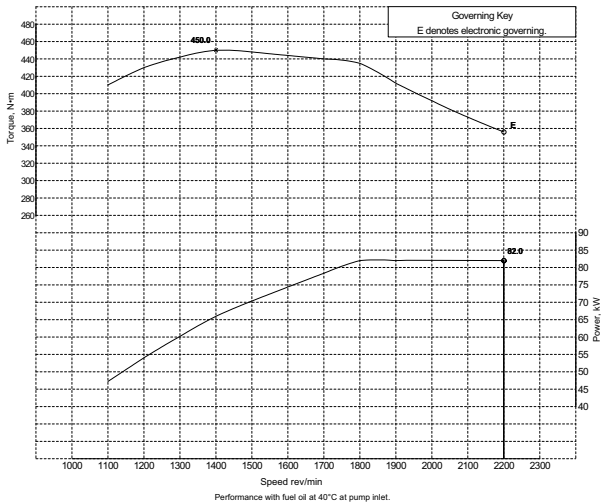

Rating	Speed rpm	Peak Power bkW	Peak Power bhp	Speed rpm	Peak Torque N·m	Peak Torque lb-ft
C	2200	74.5	100	1400	450	332.0
C*	2200	82.0	110	1400	450	332.0
B	2200	92.5	124.0	1400	530	391.0
C	2200	102.1	137.0	1400	560	413.0
C*	2200	110.1	147.6	1400	560	413.0
C	2200	117.0	157.0	1400	683	503.8
C*	2200	129.4	173.5	1400	750	553.2

*These curves are shown above.

RATING DEFINITIONS AND CONDITIONS

IND-B for service where power and/or speed are cyclic (time at full load not to exceed 80%).

IND-C (Intermittent) is the horsepower and speed capability of the engine where maximum power and/or speed are cyclic (time at full load not to exceed 50%).

Additional ratings are available for specific customer requirements. Consult your Cat dealer.

LEHH0569-00

Rating Conditions are based on ISO/TR14396, inlet air standard conditions with a total barometric pressure of 100 kPa (29.5 in Hg), with a vapor pressure of 1 kPa (.295 in Hg), and 25°C (77°F). Performance is measured using fuel to EPA specifications in 40 CFR Part 1065 and EU specifications in Directive 97/68/EC with a density of 0.845-0.850 kg/L @ 15°C (59°F) and fuel inlet temperature 40°C (104°F).



C4.4 ACERT™
Industrial Power Unit
Tier 4 Final, Stage IV Technology
74.5-129.4 kW/100-173.5 bhp @ 2200 rpm

AFTERTREATMENT CONFIGURATION

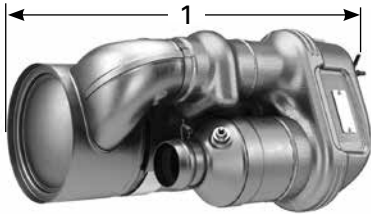

Less than or equal to 92.6 kW (124.2 bhp)

Approximate Size and Weight

- (1) Length — 647 mm (25.5 in)
 - (2) Width — 538 mm (21.18 in)
 - (3) Height — 335 mm (13.19 in)
- Weight — 40 kg (88 lb)

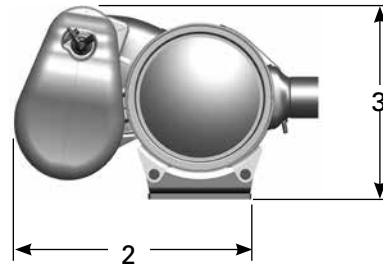

Greater than 92.6 kW (124.2 bhp)

Approximate Size and Weight

- (1) Length — 675 mm (25.6 in)
 - (2) Width — 565 mm (22.2 in)
 - (3) Height — 355 mm (13.97 in)
- Weight — 45 kg (99 lb)

AFTERTREATMENT FEATURES

Regeneration: The DOC/SCR modular design offers a simple, compact package while providing high levels of performance. While in use, the system is transparent to the operator.

Mounting: Installed on engine installation reduces the engineering and manufacturing work at the OEM.

Service: The aftertreatment is service-free for the emissions life of the engine.

Available in 12V or 24V systems

STANDARD EMISSIONS CONTROL EQUIPMENT

DOC: Diesel Oxidation Catalyst

SCR: Selective Catalytic Reduction

3" flex pipe connection kit with straight, 45°, and 90° options for flexibility

A range of SCR system components, including pump, tanks, and lines

Materials and specifications are subject to change without notice. The International System of Units (SI) is used in this publication. CAT, CATERPILLAR, their respective logos, ACERT, S•O•S, "Caterpillar Yellow" and the "Power Edge" trade dress, as well as corporate and product identity used herein, are trademarks of Caterpillar and may not be used without permission.